

AAT3169 High Efficiency 1X/1.5X/2X Charge Pump for White LED Applications

General Description

The AAT3169 is a low noise, constant frequency charge pump DC/DC converter that uses a tri-mode load switch (1X), fractional (1.5X), and doubling (2X) conversion to maximize efficiency for white LED applications. The AAT3169 is capable of driving six LEDs for a total of 180mA from a 2.7V to 5.5V input. The current sinks may be operated individually or in parallel for driving higher current LEDs. A low external parts count (two 1 μ F flying capacitors and two small 1 μ F capacitors at IN and OUTCP) make this part ideally suited for small, battery-powered applications.

Skyworks' AS²Cwire™ (Advanced Simple Serial Control) serial digital input is used to enable, disable, and set current for each LED with a 16-level logarithmic scale plus four low-current settings down to 115 μ A. For optimized efficiency, low-current settings require only 65 μ A of housekeeping current.

Each output of the AAT3169 is equipped with built-in protection for output short-circuit and auto-disable for load short-circuit conditions. Built-in soft-start circuitry prevents excessive inrush current during start-up. A low-current shutdown feature disconnects the load from the input and reduces quiescent current to less than 1 μ A.

The AAT3169 is available in a Pb-free, space-saving, thermally-enhanced 16-pin 4x4mm QFN package, a 14-pin 3x3mm TDFN package, a low-profile 14-pin 3x3mm STDFN package or a 14-pin TSOPJW package and is rated over the -40°C to +85°C temperature range.

Features

- V_{IN} Range: 2.7V to 5.5V
- Fully Programmable Current with Single Wire
 - 16-Step Logarithmic Scale
 - 15/20/30mA Max Current
 - Four Low-Current Settings Down to 115 μ A
 - Low I_Q (65 μ A) for Single-Channel, Low-Current Mode
- Tri-Mode 1X, 1.5X, and 2X Charge Pump for Maximum Efficiency and V_F Coverage
- Drives Up to Six LEDs
- Individual Main-Sub (5-1) Group Control
- No Inductors, Low Noise Operation
- 1MHz Constant Switching Frequency
- Small Application Circuit
- Built-In Thermal Protection
- Built-In Auto-Disable for Open Circuit
- Automatic Soft Start
- I_Q < 1 μ A in Shutdown
- Thermally-Enhanced TDFN33-14, STDFN33-14, QFN44-16, or TSOPJW-14 Package

Applications

- Color (RGB) Lighting
- Programmable Current Sink
- Transmissive Displays
- White LED Backlighting
- White Photo Flash for Digital Still Cameras

Typical Application

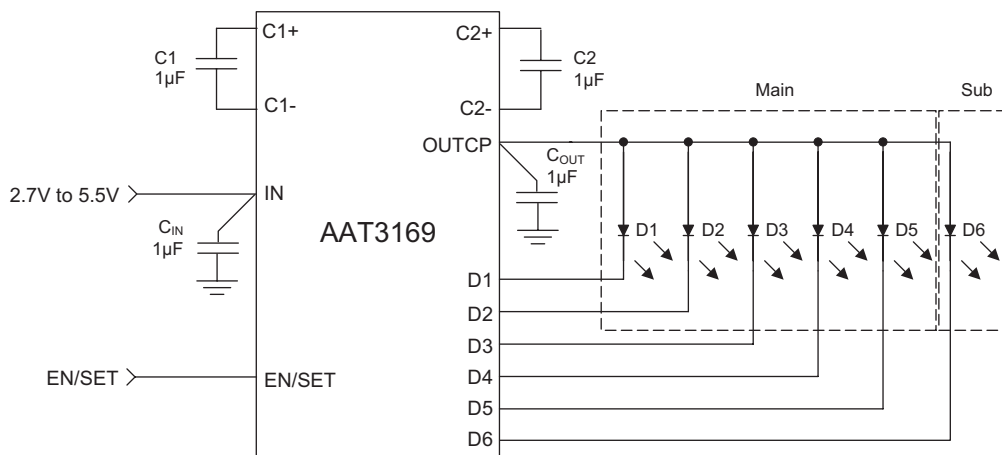

AAT3169 High Efficiency 1X/1.5X/2X Charge Pump for White LED Applications**Pin Descriptions**

Pin Number			Symbol	Function
AAT3169ISN	AAT3169IWO, AAT3169IFO	AAT3169ITO		
1	2	13	D6	Current sink input #6.
2	3	12	EN/SET	AS ² Cwire serial interface control pin.
3	n/a	n/a	N/C	No connection.
4	6	9	OUTCP	Charge pump output to drive load circuit. Requires 1 μ F capacitor connected between this pin and ground.
5	7	8	C2+	Flying capacitor 2 positive terminal. Connect a 1 μ F capacitor between C2+ and C2-.
6	4	11	C1+	Flying capacitor 1 positive terminal. Connect a 1 μ F capacitor between C1+ and C1-.
7	5	10	C1-	Flying capacitor 1 negative terminal.
8	8	7	C2-	Flying capacitor 2 negative terminal.
9, 11	10	5	GND	Ground.
10	9	6	IN	Input power supply. Requires 1 μ F capacitor connected between this pin and ground.
12	11	4	D1	Current sink input #1.
13	12	3	D2	Current sink input #2.
14	13	2	D3	Current sink input #3.
15	14	1	D4	Current sink input #4.
16	1	14	D5	Current sink input #5.
EP	n/a	n/a		Exposed paddle (bottom); connect to ground as closely as possible to the package.

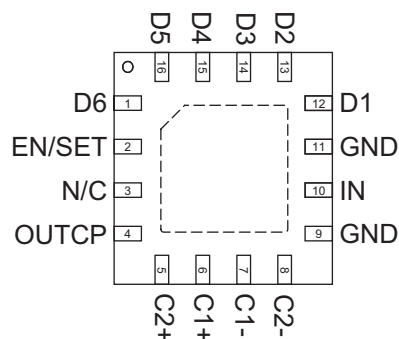
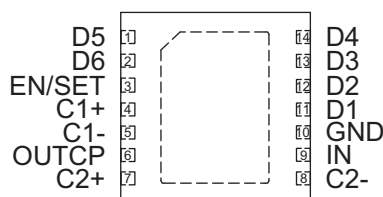
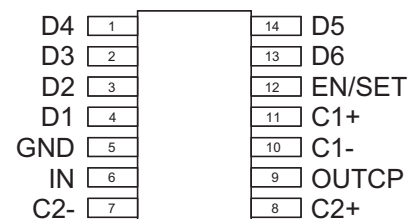
Pin Configuration**QFN44-16
(Top View)****TDFN33-14,
STDFN33-14
(Top View)****TSOPJW-14
(Top View)**

AAT3169 High Efficiency 1X/1.5X/2X Charge Pump for White LED Applications**Absolute Maximum Ratings¹**

Symbol	Description	Value	Units
V_{IN}	Input Voltage to GND	-0.3 to 6	V
$V_{EN/SET}$	EN/SET Voltage to GND	-0.3 to $V_{IN} + 0.3$	V
I_{OUT}^2	Maximum DC Output Current	210	mA
T_J	Operating Junction Temperature Range	-40 to 150	°C
T_{LEAD}	Maximum Soldering Temperature (at leads, 10 sec)	300	°C

Thermal Information³

Symbol	Description	Value	Units
P_D	Maximum Power Dissipation	QFN44-16 ⁴	W
		STDFN33-14 ⁴	
		TDFN33-14	
		TSOPJW-14	
θ_{JA}	Maximum Thermal Resistance	QFN44-16	°C/W
		TDFN33-14	
		STDFN33-14	
		TSOPJW-14	

1. Stresses above those listed in Absolute Maximum Ratings may cause permanent damage to the device. Functional operation at conditions other than the operating conditions specified is not implied. Only one Absolute Maximum Rating should be applied at any one time.

2. Based on long-term current density limitation.

3. Mounted on an FR4 board.

4. Derate 20mW/°C above 25°C.

AAT3169 High Efficiency 1X/1.5X/2X Charge Pump for White LED Applications

Electrical Characteristics¹

$C_{IN} = C_{OUT} = C_1 = C_2 = 1.0\mu\text{F}$; $T_A = -40^\circ\text{C}$ to $+85^\circ\text{C}$, unless otherwise noted. Typical values are at $T_A = 25^\circ\text{C}$, $V_{IN} = 3.6\text{V}$.

Symbol	Description	Conditions	Min	Typ	Max	Units
Input Power Supply						
V_{IN}	Operation Range		2.7		5.5	V
I_{CC}	Operating Current	1X Mode, $3.0 \leq V_{IN} \leq 5.5$, Active, No Load Current, High Current Mode		0.3		mA
		1.5X Mode, $3.0 \leq V_{IN} \leq 5.5$, Active, No Load Current, High Current Mode		1		
		2X Mode, $3.0 \leq V_{IN} \leq 5.5$, Active, No Load Current, High Current Mode		1		
		1X Mode, $3.0 \leq V_{IN} \leq 5.5$, D6 Active, No Load Current, Low Current Mode		65	90	μA
I_{SHDN}	Shutdown Current	$V_{EN/SET} = 0\text{V}$			1	μA
I_{DX}	Current Accuracy	$I_{SET} = 20\text{mA}$, $T_A = 25^\circ\text{C}$	-10		10	%
		$I_{SET} = 2.4\text{mA}$, $T_A = 25^\circ\text{C}$	-20		20	
	Low Current Accuracy	$I_{SET} = 400\mu\text{A}$, $T_A = 25^\circ\text{C}$	-20		20	
$I_{(D-Match)}$	Current Matching ²	$V_F:D1:D6 = 3.6\text{V}$		0.5		%
V_{TH}	1X to 1.5X or 1.5X to 2X Transition Threshold at Any I_{SINK} Pin	$I_{SET} = 20\text{mA}$		150		mV
Charge Pump Section						
T_{SS}	Soft-Start Time			100		μs
F_{CLK}	Clock Frequency			1000		kHz
EN/SET						
$V_{EN(L)}$	Enable Threshold Low	$V_{IN} = 2.7\text{V}$			0.4	V
$V_{EN(H)}$	Enable Threshold High	$V_{IN} = 5.5\text{V}$	1.4			V
$T_{EN/SET LO}$	EN/SET Low Time		0.3		75	μs
$T_{EN/SET HI MIN}$	Minimum EN/SET High Time			50		ns
$T_{EN/SET HI MAX}$	Maximum EN/SET High Time				75	μs
T_{OFF}	EN/SET Off Timeout				500	μs
T_{LAT}	EN/SET Latch Timeout				500	μs
$I_{EN/SET}$	EN/SET Input Leakage		-1		1	μA

1. The AAT3169 is guaranteed to meet performance specifications over the -40°C to $+85^\circ\text{C}$ operating temperature range and is assured by design, characterization, and correlation with statistical process controls.

2. Current matching is defined as the deviation of any sink current from the average of all active channels.

AAT3169

AAT3169 High Efficiency 1X/1.5X/2X Charge Pump for White LED Applications

Typical Characteristics

$C_{IN} = C_{OUT} = C_1 = C_2 = 1.0\mu F$, $V_{IN} = 3.6V$, $T_A = 25^\circ C$, unless otherwise noted.

Efficiency vs. Supply Voltage

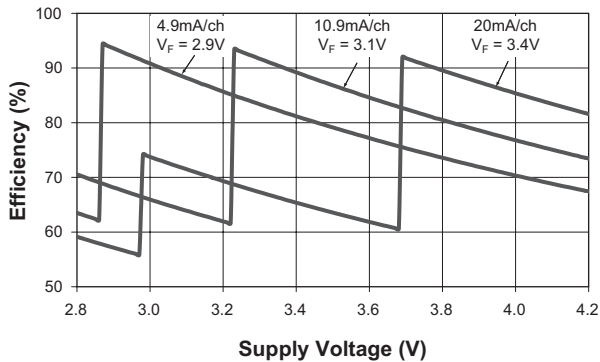

Turn-On to 1X Mode
($V_{IN} = 4.2V$; 20mA/Channel)

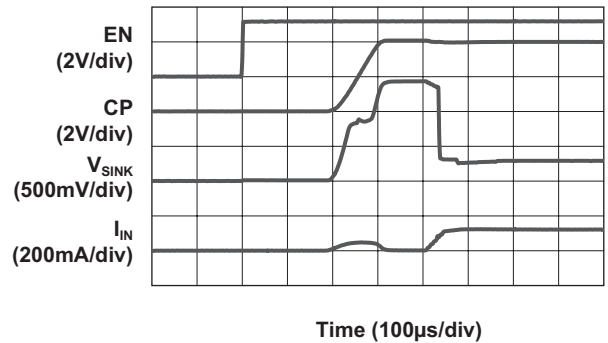

Turn-On to 1.5X Mode
($V_{IN} = 3.8V$; 20mA/Channel)

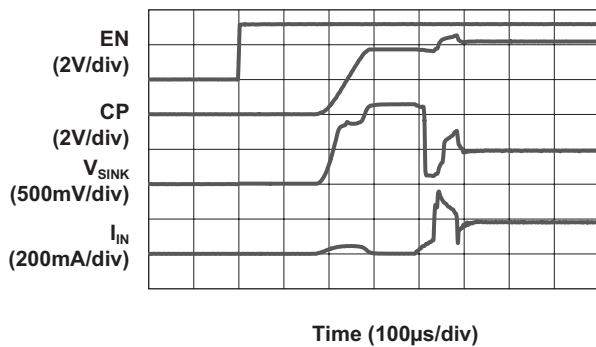

Turn-On to 2X Mode
($V_{IN} = 2.8V$; 20mA/Channel)

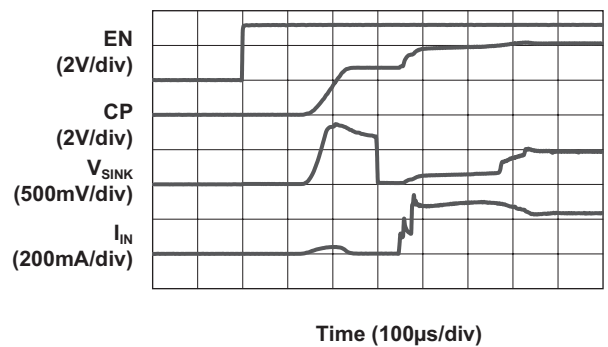

Turn-Off from 1.5X Mode
($V_{IN} = 3.5V$; 20mA/Channel)

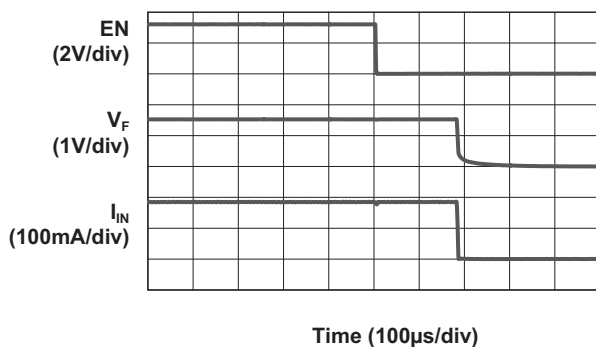

Current Matching vs. Temperature

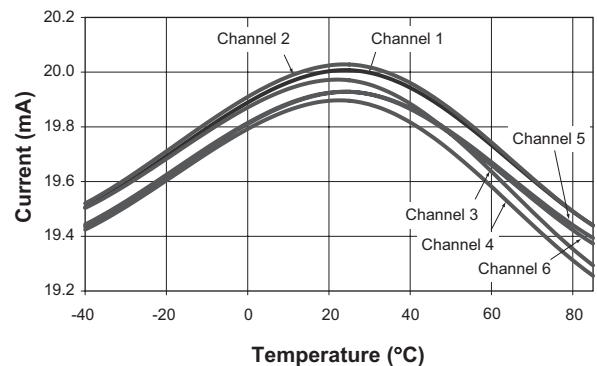

AAT3169 High Efficiency 1X/1.5X/2X Charge Pump for White LED Applications

Typical Characteristics

$C_{IN} = C_{OUT} = C_1 = C_2 = 1.0\mu F$, $V_{IN} = 3.6V$, $T_A = 25^\circ C$, unless otherwise noted.

Load Characteristics
($V_{IN} = 3.8V$; 1.5X Mode; 15mA/Channel)

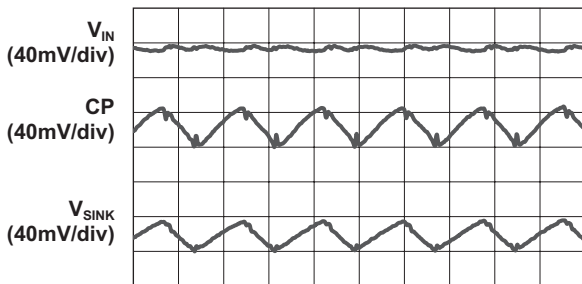

Time (500ns/div)

Load Characteristics
($V_{IN} = 2.9V$; 2X Mode; 15mA/Channel)

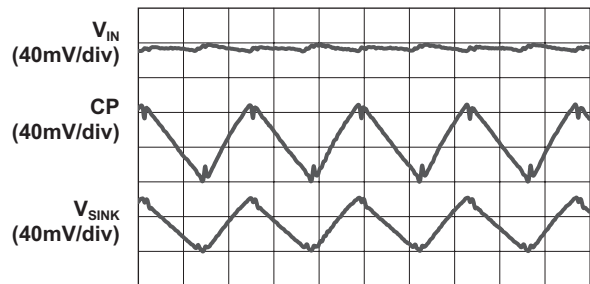

Time (500ns/div)

Load Characteristics
($V_{IN} = 4.0V$; 1.5X Mode; 20mA/Channel)

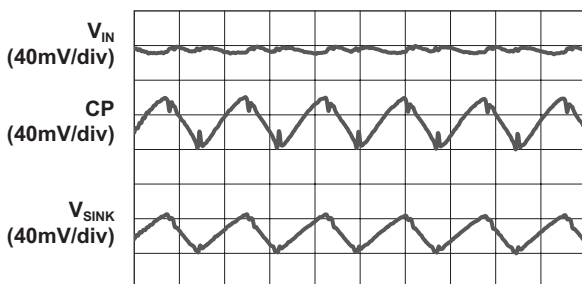

Time (500ns/div)

Load Characteristics
($V_{IN} = 3.1V$; 2X Mode; 20mA/Channel)

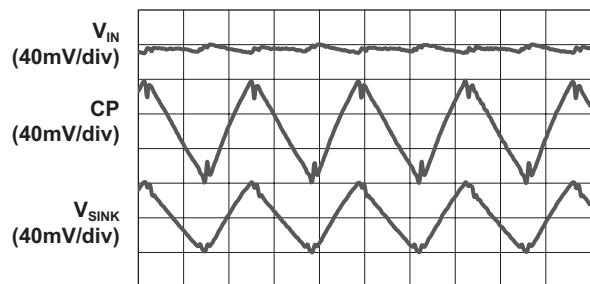

Time (500ns/div)

Load Characteristics
($V_{IN} = 4.3V$; 1.5X Mode; 30mA/Channel)

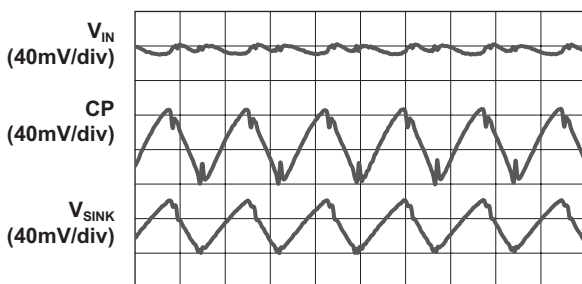

Time (500ns/div)

Load Characteristics
($V_{IN} = 3.6V$; 2X Mode; 30mA/Channel)

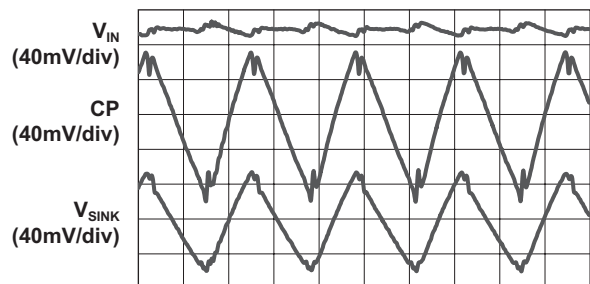

Time (500ns/div)

AAT3169

AAT3169 High Efficiency 1X/1.5X/2X Charge Pump for White LED Applications

Typical Characteristics

$C_{IN} = C_{OUT} = C_1 = C_2 = 1.0\mu F$, $V_{IN} = 3.6V$, $T_A = 25^\circ C$, unless otherwise noted.

T_{LAT} vs. V_{IN}

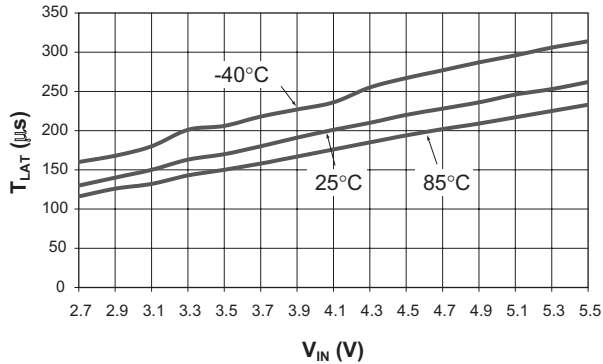

T_{OFF} vs. V_{IN}

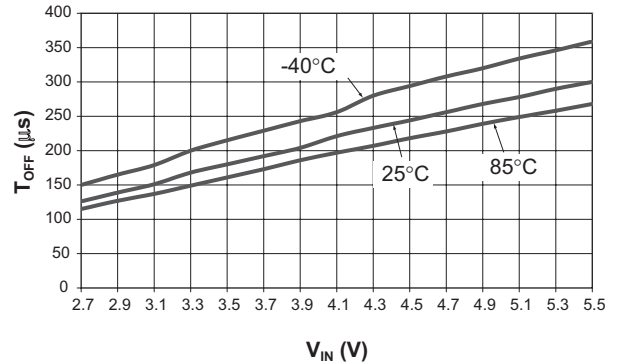

Input Ripple vs. V_{IN}

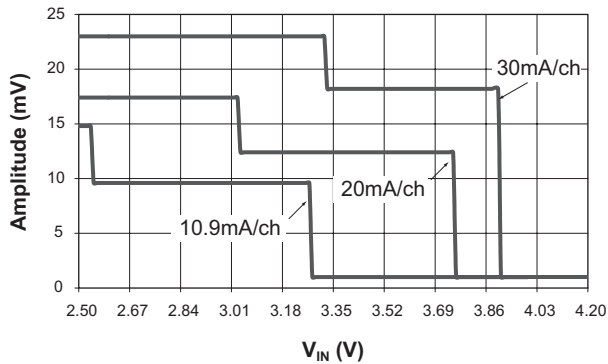

V_{IH} vs. V_{IN}

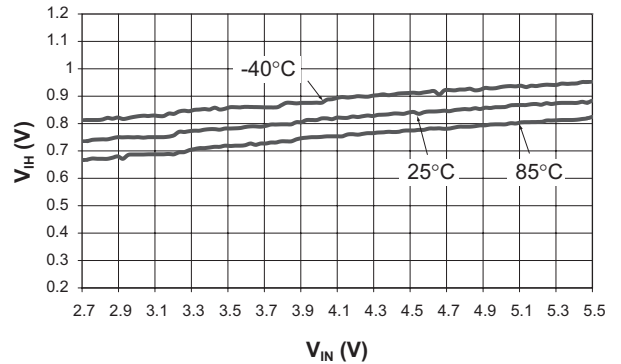

V_{IL} vs. V_{IN}

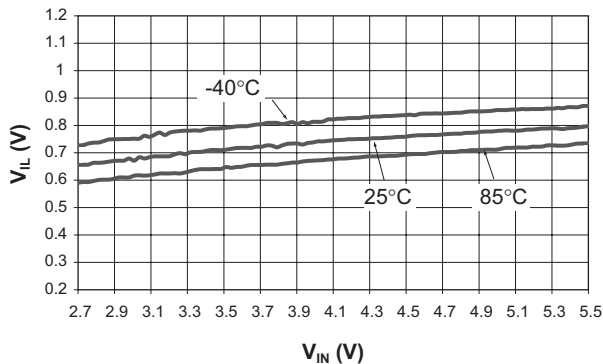

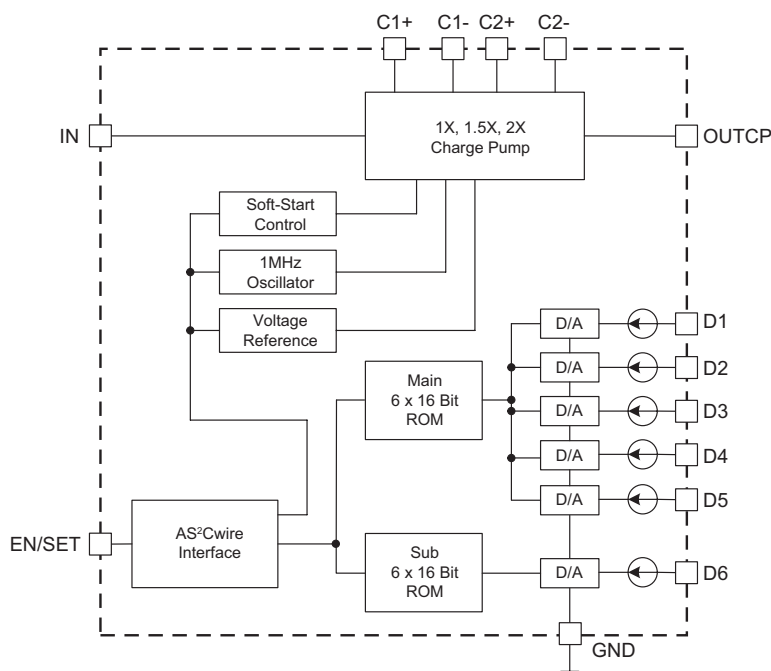
AAT3169 High Efficiency 1X/1.5X/2X Charge Pump for White LED Applications**Functional Block Diagram****Functional Description**

The AAT3169 is a tri-mode load switch (1X) and high efficiency (1.5X or 2X) charge pump device intended for white LED backlight applications. To maximize power conversion efficiency, an internal sensing circuit monitors the voltage required on each constant current sink input and sets the load switch and charge pump modes based on the input battery voltage and the current sink input voltage. As the battery discharges over time, the AAT3169 charge pump is enabled when any of the six current sink inputs near dropout. The charge pump initially starts in 1.5X mode. If the charge pump output droops enough for any current source output to become close to dropout, the charge pump will automatically transition to 2X mode. The AAT3169 requires only four external components: two $1\mu\text{F}$ ceramic capacitors for the charge pump flying capacitors (C1 and C2), one $1\mu\text{F}$ ceramic input capacitor (C_{IN}), and one $0.33\mu\text{F}$ to $1\mu\text{F}$ ceramic charge pump output capacitor (C_{OUT}).

The six constant current sink inputs (D1 to D6) can drive six individual LEDs with a maximum current of 30mA nominal each. Unused sink inputs should be connected to OUTCP, otherwise the part will operate only in 2X charge pump mode. The AS²Cwire serial interface enables the AAT3169 and sets the current sink magnitudes. AS²Cwire addressing allows independent control

of two groups of current sink input: D1~D5 and D6.

Constant Current Output Level Settings

The constant current sink levels for D1 to D6 are set via the serial interface according to a logarithmic scale where each code is approximately 1.8dB lower than the previous code. In this manner, LED brightness appears linear with each increasing code count. Because the inputs D1 to D6 are true independent constant current sinks, the voltage observed on any single given input will be determined by the actual forward voltage (V_F) for the LED being driven.

Since the input current sinks of the AAT3169 are programmable, no PWM (pulse width modulation) or additional control circuitry is needed to control LED brightness. This feature greatly reduces the burden on a microcontroller or system IC to manage LED or display brightness, allowing the user to “set it and forget it.” With its high-speed serial interface (1MHz data rate), the input sink current of the AAT3169 can be changed successively to brighten or dim LEDs in smooth transitions (e.g., to fade-out) or in abrupt steps, giving the user complete programmability and real-time control of LED brightness.

The 16 individual current level settings are each approximately 1.8dB apart (see Table 1). Code 1 is full scale; Code 15 is full scale attenuated by approximately 25dB; and Code 16 is reserved as a “no current” setting.

AAT3169 High Efficiency 1X/1.5X/2X Charge Pump for White LED Applications

Data	Mean 30mA Max	Mean 20mA Max	Mean 15mA Max
1	30.0	20.0 ¹	15.0
2	29.3	19.5	14.6
3	27.8	18.5	13.9
4	25.2	17.0	12.7
5	22.8	15.4	11.5
6	20.9	14.2	10.5
7	18.5	12.5	9.3
8	16.1	10.9	8.1
9	13.7	9.3	7.0
10	11.5	8.0	6.0
11	9.4	6.5	4.9
12	7.0	4.9	3.7
13	4.7	3.3	2.6
14	3.3	2.4	1.9
15	1.9	1.5	1.2
16	0.0	0.0	0.0

Table 1: Mean Table of AAT3169 Output Current.**AS²Cwire Serial Interface**

The current sink input magnitude on the AAT3169 is controlled by Skyworks' Advanced Simple Serial Control (AS²Cwire) serial digital input. AS²Cwire adds addressing capability for multiple data registers over the Simple Serial Control™ (S²Cwire™), which is only capable of controlling a single register. The AAT3169 has four registers: Bank1, Bank2, Max Current, and Low Current.

Three addresses are used to control the two registers. Address 0 addresses both registers simultaneously to allow the loading of both registers with the same data using a single write protocol. Address 1 addresses Register 1 for D1 to D5 current level settings. Address 2 addresses Register 2 for D6 current level settings.

AS²Cwire relies on the number of rising edges of the EN/SET pin to address and load the registers. AS²Cwire latches data or address after the EN/SET pin has been held high for time T_{LAT} . Address or data is differentiated by the number of EN/SET rising edges. Since the data registers are 4 bits each, the differentiating number of pulses is 2^4 or 16, so that Address 0 is signified by 17 rising edges, Address 1 by 18 rising edges, and Address 2 by 19 rising edges. Data is set to any number of rising edges between 1 and including 16. A typical write protocol is a burst of EN/SET rising edges, signifying a particular address, followed by a pause with EN/SET held

high for the T_{LAT} timeout period, a burst of rising edges signifying data, and a T_{LAT} timeout for the data registers. Once an address is set, then multiple writes consisting of data only (without address) to the corresponding data register are allowed. Address 0 is the default address on the first rising edge after the AAT3169 has been disabled. If data is presented on the first rising edge with no prior address, both data registers are simultaneously loaded.

The maximum current level is determined by the value set in Register 3, the Max Current register. Three scales are available for high operating currents with maximum current levels of 30mA, 20mA, or 15mA. Each scale maintains approximately 1.8dB steps between settings. A separate mode is available for ultra-low LED current operation. When the Max Current register (Register 3) is set to the Low Current setting, the Low Current register (Register 4) must be programmed. The two most significant bits of the Low Current register control whether or not a given bank of current sinks is enabled. The least two significant bits of the Low Current register sets the current level for both banks. For low current settings, the charge pump may be enabled if required by the battery voltage and LED forward voltage conditions, and 1X mode quiescent current is approximately 130 μ A for multiple channels or 65 μ A for Channel 6 operation only. Both banks of current sinks must be in the same high or low current mode of operation.

When EN/SET is held low for an amount of time greater than T_{OFF} the AAT3169 enters shutdown mode and draws less than 1 μ A from the input. During shutdown, the address register is reset to 0 and data registers are reset to their default values.

AS²Cwire Serial Interface Addressing

Address	EN/SET Rising Edges	Data Register AAT3169
0 ¹	17	1&2: D1~D6 Current
1	18	1: D1~D5 Current
2	19	2: D6 Current
3	20	3: Max Current
4	21	4: Low Current
Data	Max Current	
1 ¹	20mA	
2	30mA	
3	15mA	
4	Low Current (see Low Current Register for values)	

1. Denotes the default values after EN/SET is toggled high.

AAT3169 High Efficiency 1X/1.5X/2X Charge Pump for White LED Applications**Low Current Register (Address 4)**

Data	Main Low Current On	Sub Low Current On	Current
1	No	No	
2	No	No	
3	No	No	
4	No	No	
5	No	Yes	115 μ A
6	No	Yes	175 μ A
7	No	Yes	280 μ A
8	No	Yes	400 μ A
9	Yes	No	115 μ A
10	Yes	No	175 μ A
11	Yes	No	280 μ A
12	Yes	No	400 μ A
13	Yes	Yes	115 μ A
14	Yes	Yes	175 μ A
15	Yes	Yes	280 μ A
16	Yes	Yes	400 μ A

Auto-Disable Feature

AAT3169 is equipped with an auto-disable feature for each LED channel. After the IC is enabled and started up, a test current of 120 μ A (typical) is forced through each sink channel. The channel will be disabled if the voltage of that particular SINK pin does not drop to a certain threshold. This feature is very convenient for disabling an unused channel or during an LED fail-short event.

Thermal Protection

The AAT3169 has a built-in thermal protection circuit that will shut down the charge pump if the die temperature rises above the thermal limit, as would be the case during a short circuit of the OUTCP pin.

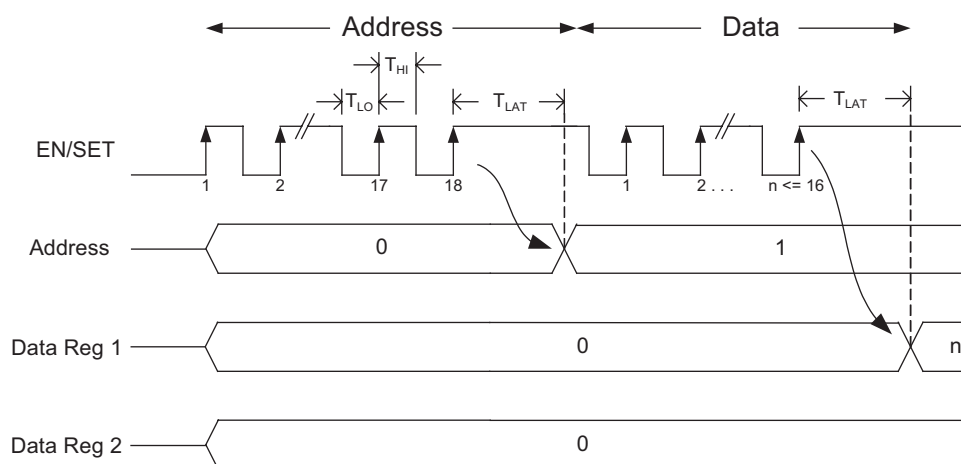
AS²Cwire Serial Interface Timing

AAT3169 High Efficiency 1X/1.5X/2X Charge Pump for White LED Applications**Applications Information****LED Selection**

Although the AAT3169 is designed for driving white LEDs, the device also can be used to drive most types of LEDs with forward voltages from 2.0V to 4.7V. LED applications may include main and sub-LCD display backlighting, camera photo-flash applications, color (RGB) LEDs, infrared (IR) diodes for remotes, and other loads benefiting from a controlled output current generated from a varying input voltage. Since the D1 to D6 input current sinks are matched with negligible voltage dependence, the LED brightness will be matched regardless of the specific LED forward voltage (V_F) levels.

In some instances (e.g., in high luminous output applications such as photo flash), it may be necessary to drive high- V_F type LEDs. The low dropout current sinks in the AAT3169 make it capable of driving LEDs with forward voltages as high as 4.7V at full current from an input supply as low as 3.0V. Outputs can be paralleled to drive high-current LEDs without complication.

Device Switching Noise Performance

The AAT3169 operates at a fixed frequency of approximately 1MHz to control noise and limit harmonics that can interfere with the RF operation of cellular telephone handsets or other communication devices. Back-injected noise appearing on the input pin of the charge pump is 20mV peak-to-peak, typically ten times less than inductor-based DC/DC boost converter white LED backlight solutions. The AAT3169 soft-start feature prevents noise transient effects associated with inrush currents during start-up of the charge pump circuit.

Capacitor Selection

Careful selection of the four external capacitors (C_{IN} , C_1 , C_2 , and C_{OUT}) is important because they will affect turn-on time, output ripple, and transient performance. Optimum performance will be obtained when low ESR ceramic capacitors are used; in general, low ESR may be defined as less than 100m Ω . A value of 1 μ F for all four capacitors is a good starting point when choosing capacitors. If the LED current sources are programmed only for light current levels, then the capacitor size may be decreased.

Capacitor Characteristics

Ceramic composition capacitors are highly recommended over all other types of capacitors for use with the AAT3169. Ceramic capacitors offer many advantages over their tantalum and aluminum electrolytic counterparts. A ceramic capacitor typically has very low Equivalent Series Resistance (ESR), is lowest cost, has a smaller PCB footprint, and is non-polarized. Low ESR ceramic capacitors help maximize charge pump transient response. Since ceramic capacitors are non-polarized, they are not prone to incorrect connection damage.

Equivalent Series Resistance

ESR is an important characteristic to consider when selecting a capacitor. ESR is resistance internal to a capacitor that is caused by the leads, internal connections, size or area, material composition, and ambient temperature. Capacitor ESR is typically measured in milliohms for ceramic capacitors and can range to more than several ohms for tantalum or aluminum electrolytic capacitors.

Ceramic Capacitor Materials

Ceramic capacitors less than 0.1 μ F are typically made from NPO or COG materials. NPO and COG materials generally have tight tolerance and are very stable over temperature. Larger capacitor values are usually composed of X7R, X5R, Z5U, or Y5V dielectric materials. Large ceramic capacitors (i.e., greater than 2.2 μ F) are often available in low-cost Y5V and Z5U dielectrics, but capacitors greater than 1 μ F are not typically required for AAT3169 applications.

Capacitor area is another contributor to ESR. Capacitors that are physically large will have a lower ESR when compared to an equivalent material smaller capacitor. These larger devices can improve circuit transient response when compared to an equal value capacitor in a smaller package size.

AAT3169

AAT3169 High Efficiency 1X/1.5X/2X Charge Pump for White LED Applications

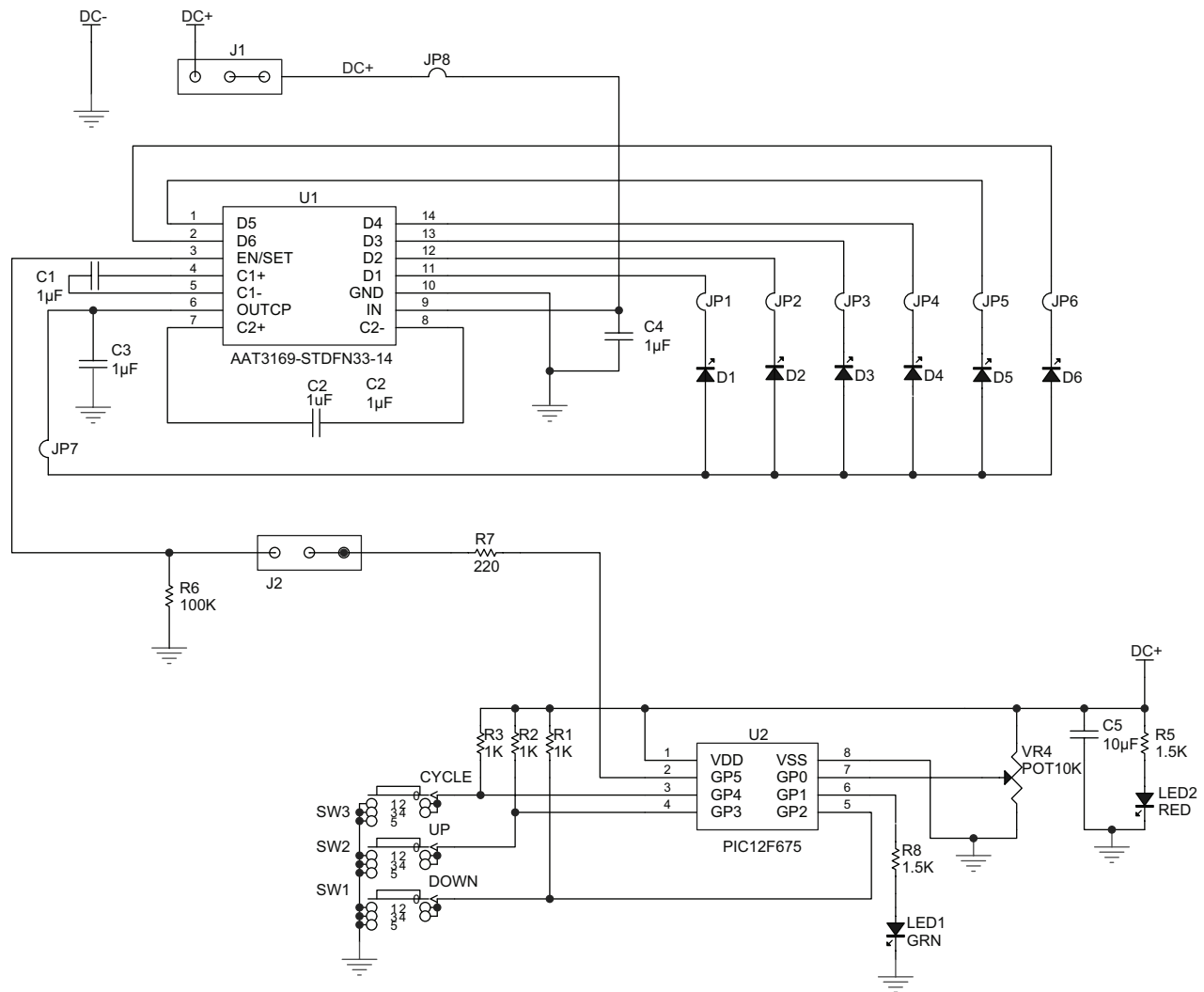

Figure 1: AAT3169IFO Evaluation Board Schematic.

AAT3169

AAT3169 High Efficiency 1X/1.5X/2X Charge Pump for White LED Applications

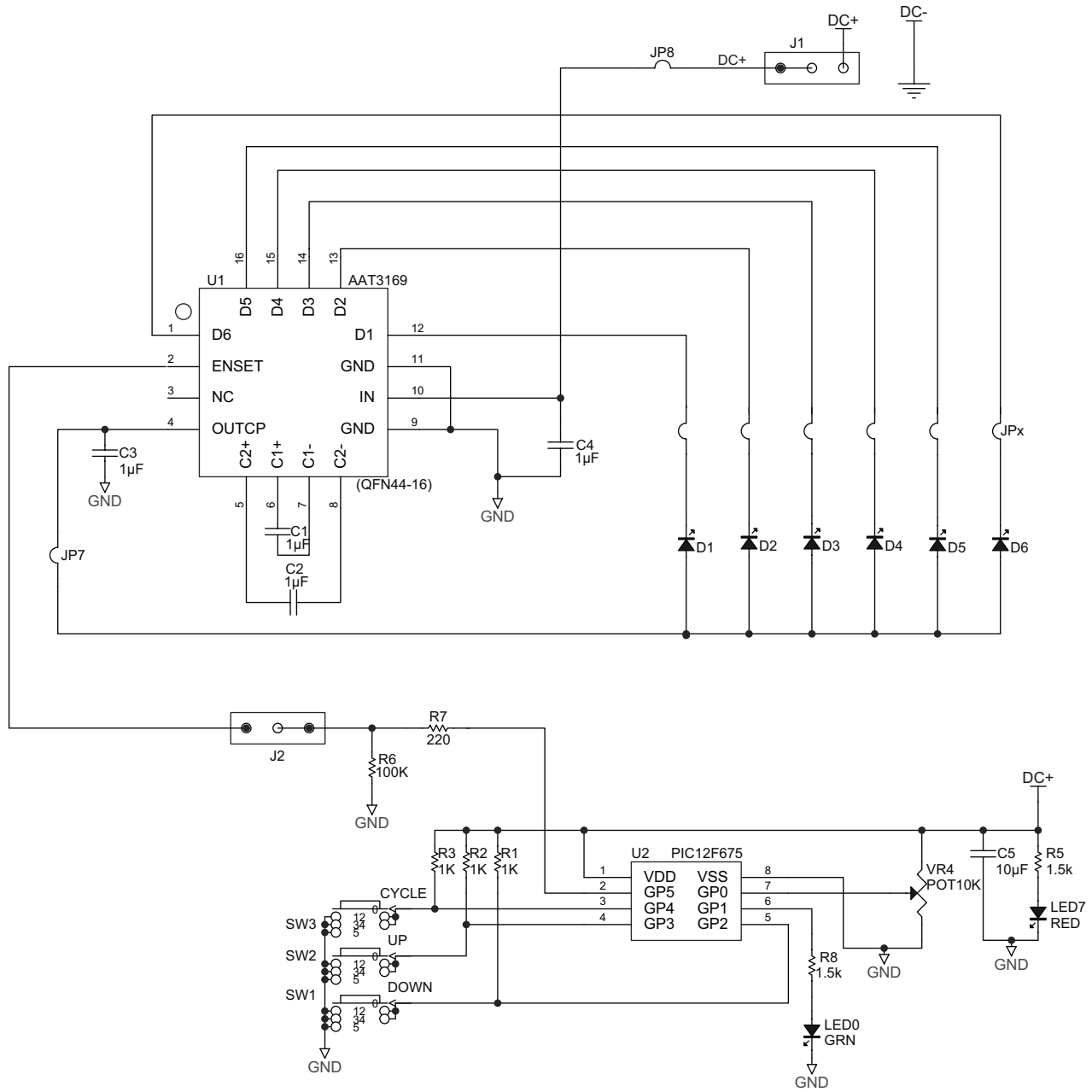

Figure 2: AAT3169ISN Evaluation Board Schematic.

AAT3169

AAT3169 High Efficiency 1X/1.5X/2X Charge Pump for White LED Applications

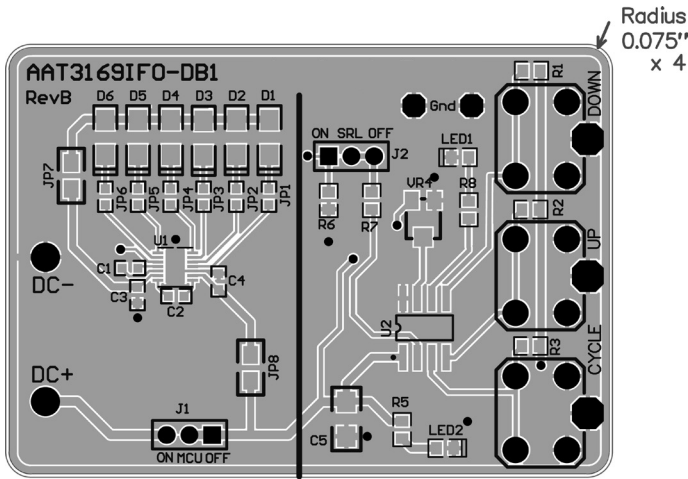

Figure 4: AAT3169IFO Evaluation Board Top Side Layout.

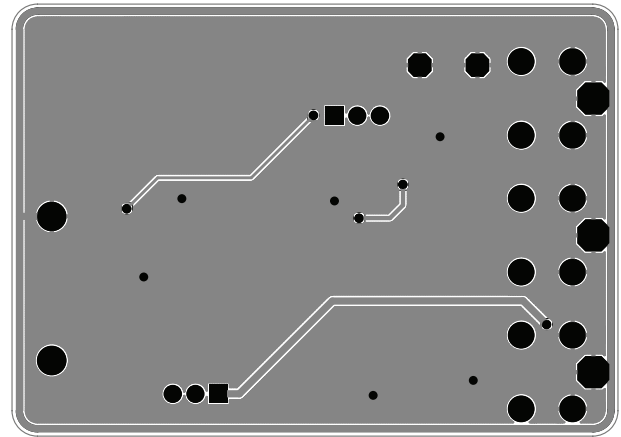

Figure 5: AAT3169IFO Evaluation Board Bottom Side Layout.

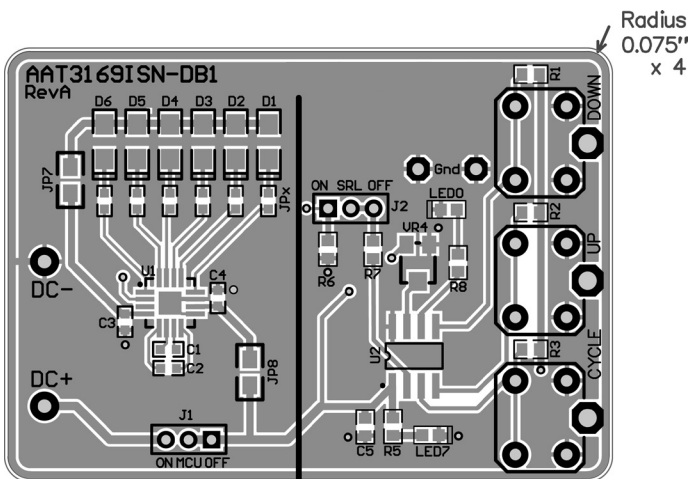

Figure 6: AAT3169ISN Evaluation Board Top Side Layout.

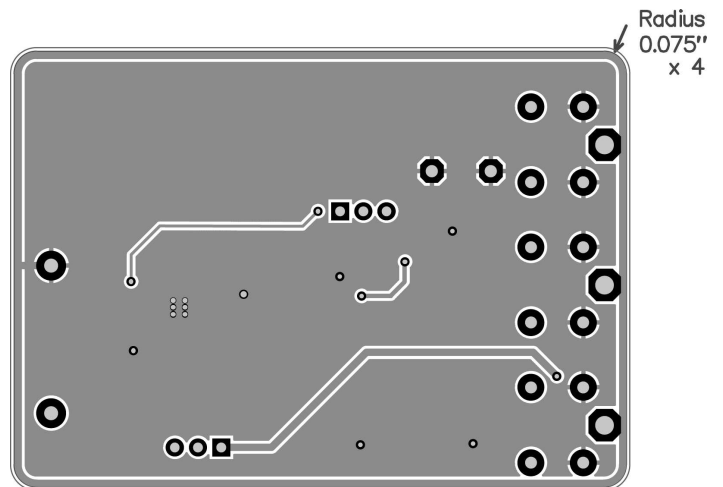
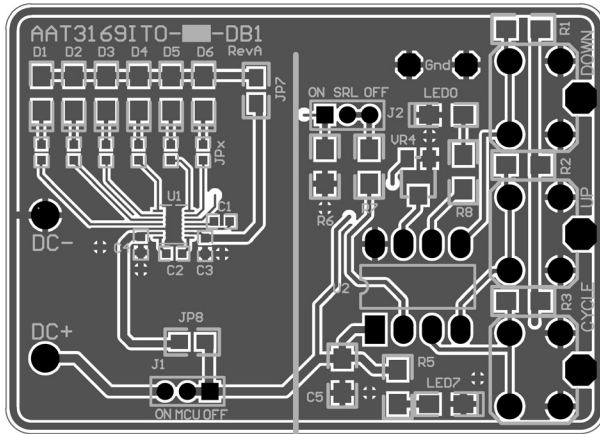
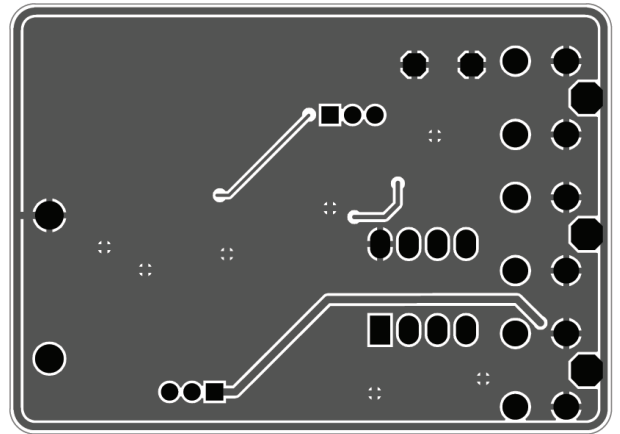

Figure 7: AAT3169ISN Evaluation Board Bottom Side Layout.

AAT3169**AAT3169 High Efficiency 1X/1.5X/2X Charge Pump for White LED Applications**

**Figure 8: AAT3169ITO Evaluation Board
Top Side Layout.**



**Figure 9: AAT3169ITO Evaluation Board
Bottom Side Layout.**

AAT3169 High Efficiency 1X/1.5X/2X Charge Pump for White LED Applications**Ordering Information**

Package	Marking ¹	Part Number (Tape and Reel) ²
STDFN33-14	UNXYY	AAT3169IFO-T1
QFN44-16	RVXYY	AAT3169ISN-T1
TSOPJW-14	7LXYY	AAT3169ITO-T1
TDFN33-14	7ZXYY	AAT3169IWO-T1



Skyworks Green™ products are compliant with all applicable legislation and are halogen-free.

For additional information, refer to *Skyworks Definition of Green™*, document number SQ04-0074.

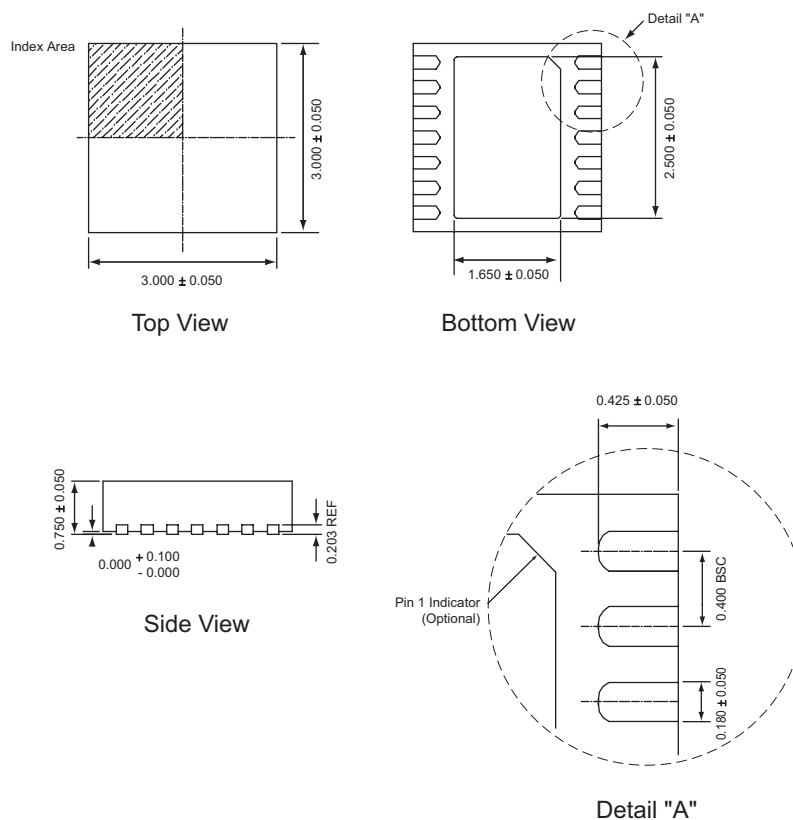
Package Information³**TDFN33-14**

All dimensions in millimeters.

1. XYY = assembly and date code.
2. Sample stock is generally held on part numbers listed in **BOLD**.
3. The leadless package family, which includes QFN, TQFN, DFN, TDFN and STDFN, has exposed copper (unplated) at the end of the lead terminals due to the manufacturing process. A solder fillet at the exposed copper edge cannot be guaranteed and is not required to ensure a proper bottom solder connection.

AAT3169

AAT3169 High Efficiency 1X/1.5X/2X Charge Pump for White LED Applications

STDFN33-14

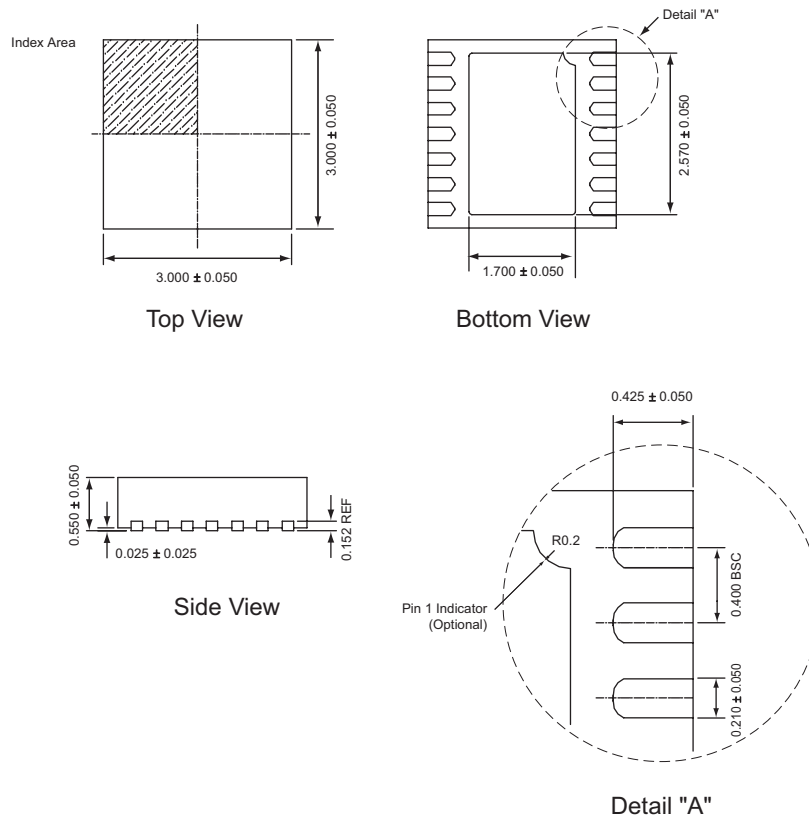

QFN44-16

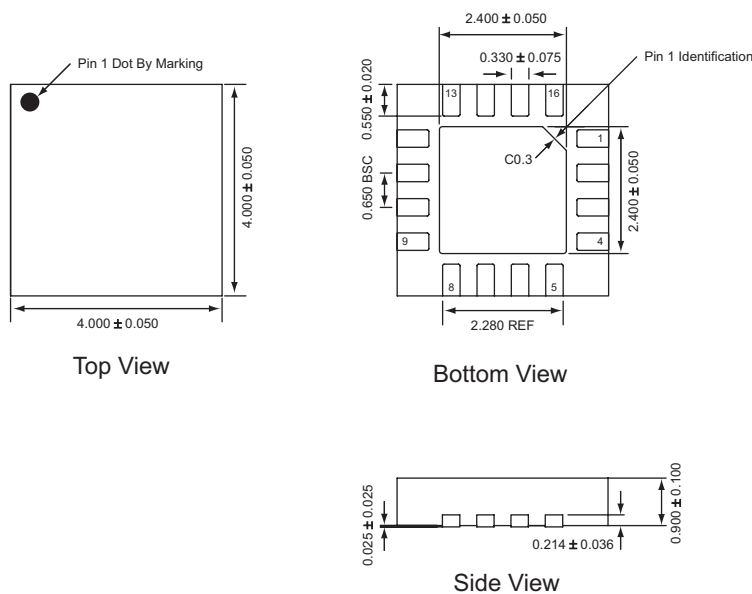

All dimensions in millimeters.

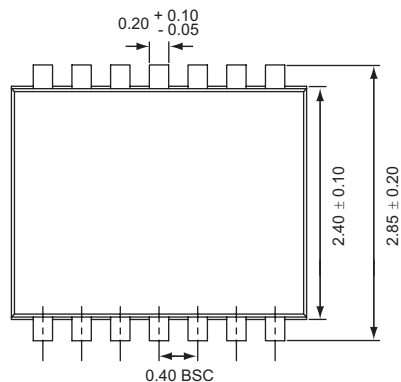
AAT3169 High Efficiency 1X/1.5X/2X Charge Pump for White LED Applications**TSOPJW-14**

Top View

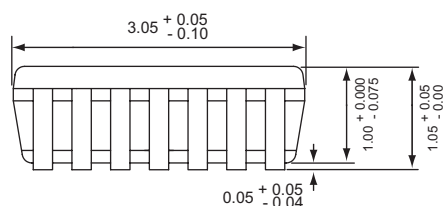

Side View

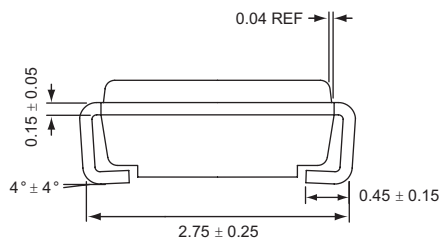

End View

All dimensions in millimeters.

Copyright © 2012 Skyworks Solutions, Inc. All Rights Reserved.

Information in this document is provided in connection with Skyworks Solutions, Inc. ("Skyworks") products or services. These materials, including the information contained herein, are provided by Skyworks as a service to its customers and may be used for informational purposes only by the customer. Skyworks assumes no responsibility for errors or omissions in these materials or the information contained herein. Skyworks may change its documentation, products, services, specifications or product descriptions at any time, without notice. Skyworks makes no commitment to update the materials or information and shall have no responsibility whatsoever for conflicts, incompatibilities, or other difficulties arising from any future changes.

No license, whether express, implied, by estoppel or otherwise, is granted to any intellectual property rights by this document. Skyworks assumes no liability for any materials, products or information provided hereunder, including the sale, distribution, reproduction or use of Skyworks products, information or materials, except as may be provided in Skyworks Terms and Conditions of Sale.

THE MATERIALS, PRODUCTS AND INFORMATION ARE PROVIDED "AS IS" WITHOUT WARRANTY OF ANY KIND, WHETHER EXPRESS, IMPLIED, STATUTORY, OR OTHERWISE, INCLUDING FITNESS FOR A PARTICULAR PURPOSE OR USE, MERCHANTABILITY, PERFORMANCE, QUALITY OR NON-INFRINGEMENT OF ANY INTELLECTUAL PROPERTY RIGHT; ALL SUCH WARRANTIES ARE HEREBY EXPRESSLY DISCLAIMED. SKYWORKS DOES NOT WARRANT THE ACCURACY OR COMPLETENESS OF THE INFORMATION, TEXT, GRAPHICS OR OTHER ITEMS CONTAINED WITHIN THESE MATERIALS. SKYWORKS SHALL NOT BE LIABLE FOR ANY DAMAGES, INCLUDING BUT NOT LIMITED TO ANY SPECIAL, INDIRECT, INCIDENTAL, STATUTORY, OR CONSEQUENTIAL DAMAGES, INCLUDING WITHOUT LIMITATION, LOST REVENUES OR LOST PROFITS THAT MAY RESULT FROM THE USE OF THE MATERIALS OR INFORMATION, WHETHER OR NOT THE RECIPIENT OF MATERIALS HAS BEEN ADVISED OF THE POSSIBILITY OF SUCH DAMAGE.

Skyworks products are not intended for use in medical, lifesaving or life-sustaining applications, or other equipment in which the failure of the Skyworks products could lead to personal injury, death, physical or environmental damage. Skyworks customers using or selling Skyworks products for use in such applications do so at their own risk and agree to fully indemnify Skyworks for any damages resulting from such improper use or sale.

Customers are responsible for their products and applications using Skyworks products, which may deviate from published specifications as a result of design defects, errors, or operation of products outside of published parameters or design specifications. Customers should include design and operating safeguards to minimize these and other risks. Skyworks assumes no liability for applications assistance, customer product design, or damage to any equipment resulting from the use of Skyworks products outside of stated published specifications or parameters.

Skyworks, the Skyworks symbol, and "Breakthrough Simplicity" are trademarks or registered trademarks of Skyworks Solutions, Inc., in the United States and other countries. Third-party brands and names are for identification purposes only, and are the property of their respective owners. Additional information, including relevant terms and conditions, posted at www.skyworksinc.com, are incorporated by reference.