

Product Overview

The GP502 ZigBee-ready IEEE 802.15.4 communications controller is a fully integrated transceiver solution for ultra-low power wireless communications. It is compliant with the IEEE Standard 802.15.4, providing robust spread spectrum data communication with a secure encrypted data flow.

The GP502 interference robustness and antenna diversity offer superior performance in a crowded wireless 2.4 GHz environment. In addition, the GP502 presents a Coexistence Interface to enable coexistence with other potentially interfering radios (Bluetooth, Wi-Fi) within the same host device.

The GP502 provides a high-speed serial interface (SPI or UART) to the host processor.

It supports stand-alone RF4CE DutyCycling and packet filtering through Deep Packet Inspection when the host is asleep and has an extremely low standby power consumption enabling total system power consumption of less than 1 mW while allowing reception of remote control commands

The GP502 is optimized for low cost while providing superior performance. Its radio characteristics reduce the product's RF design complexity enabling low cost single layer applications using simple PCB antennas requiring no shielding and a minimum number of external components.

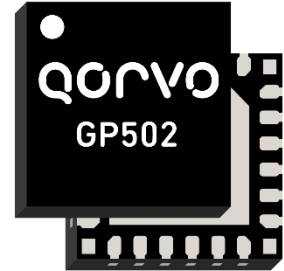

Chip Overview

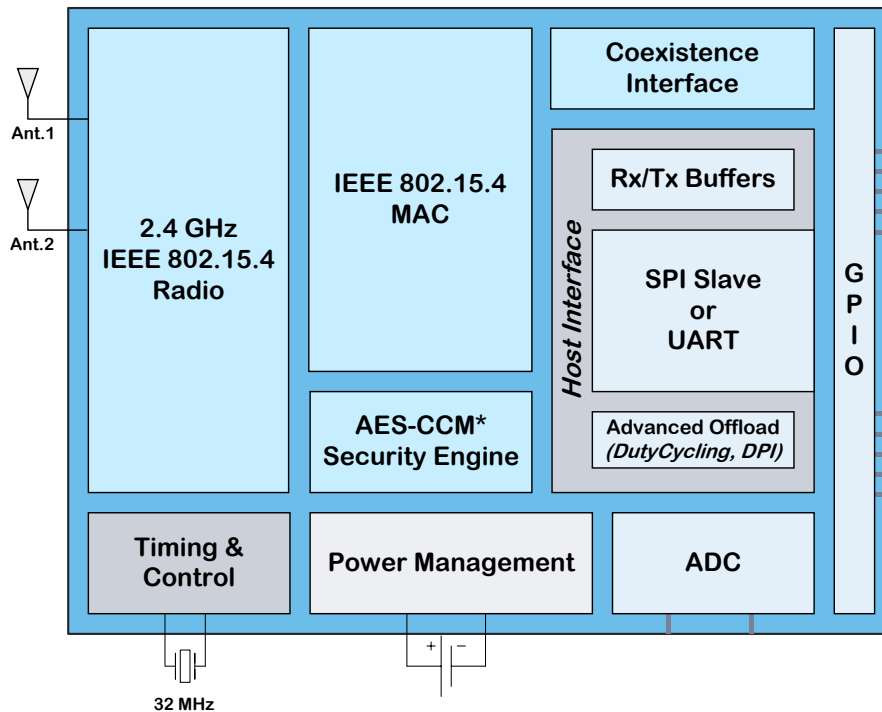

Key Features

- IEEE 802.15.4 compliant PHY and Real-Time MAC
- Operates in the worldwide 2.4 GHz ISM-band
- Excellent range by antenna diversity: 8 dB more reliable link budget compared to single antenna
- Additional robustness by packet-in-packet resynchronization
- 30 dB better robustness to Wi-Fi Interference
- External PA signals for extended range
- Hardware accelerated AES and CCM* encryption with 128, 192 and 256-bit keys
- 8 Kbyte RAM for data buffering
- Extremely low standby power consumption
- External Controller SPI or UART Slave interface
- Stand-alone RF4CE DutyCycling support and RF4CE packet filtering when the host is asleep
- Coexistence Interface with other radios in the device

Excellent Range and Reliability

The GP502 has been optimized for reliable communication in harsh radio environments. The excellent receiver sensitivity and high transmit power allow extended coverage. Built-in antenna diversity with two antennas improves the reliable link budget by 8 dB resulting in approximately twice the reliable range compared to similar systems with only one antenna. In high density networks the packet-in-packet resynchronization further improves the communication reliability. The potential risks of interference by Wi-Fi and/or Bluetooth devices have been reduced by an excellent receiver interference rejection capability and dynamic adaption of the frequency channel.

The Coexistence Interface can be used to enable coexistence of the IEEE 802.15.4 radio of the GP502 with other potentially interfering radios (Wi-Fi, Bluetooth) within the same device.

Ultra-Low Power Consumption

The GP502 is designed for ultra-low power network applications. It supports RF4CE duty cycling and can wake up the host when a specified message has been received, with RF4CE Network layer and Profile layer Deep Packet Inspection, to allow the host to stay asleep as much as possible.

Low Cost

The GP502 is designed to operate on PCB designs using only low cost components and printed circuit antennas. No expensive shielding, chip antennas or voltage regulators are required.

General Characteristics

Package	QFN24, 4x4 mm
Operating Temperature	-40 to +85 °C (industrial)
Storage Temperature	-50 to +150 °C
Soldering Temperature	260 °C (10 s max)
Compliance	RoHS

Electrical Characteristics

Standby Mode Currents ¹	
Using internal RC oscillator	1.2 µA
Using crystal oscillator	760 µA
Operational Currents ¹	
Receive	7 mA
Transmit (at 0 dBm)	18 mA
Transmit (at 7 dBm)	30 mA
Supply Voltage	2.1 to 3.6 V
Interfaces	
SPI Slave serial host interface	
UART-based serial host interface	
Coexistence Interface with other radios	
External LNA/PA signals	
2 Analog input lines	
ADC to monitor the analog input lines and the power supply level	
Crystal Frequency	32.000 MHz (±40 ppm)

Radio Characteristics

Standards compliant	IEEE 802.15.4-2003 IEEE 802.15.4-2006
Radio Regulations compliant	ETSI EN 300 328 FCC CFR-47 Part 15 ARIB STD-T66
Frequency Band	2400 – 2483.5 MHz
Channels	16 (programmable, 5 MHz steps)
Modulation	IEEE 802.15.4
Chip rate	2 Mchip/s
Data Rate	250 kbit/s
Receiver Sensitivity ¹	-95 dBm typical
Antenna diversity gain ² (increases the 'effective' receiver sensitivity to -103 dBm)	8 dB
Transmit Power	+7 dBm (adjustable down in 1 dB steps)
Radio Management	Antenna Diversity Digital RSSI Link Quality Indication

- 1) Typical, at 3.0 V and 25 °C, unless specified otherwise.
- 2) For typical indoor usage in an environment with 50 ns delay spread and 2 MHz signal bandwidth using the Rayleigh fading model: antenna diversity with 2 antennas results in a 8 dB improved link budget at a 1% outage probability compared to no antenna diversity. The 8 dB in link budget translates into 70% more range, if using a two slope range model with the breakpoint at 10 m and $g_1 = 2$, $g_2 = 3.5$.

Reference Designs, Tools and SW

Qorvo reference designs, development kits, software libraries and production platforms provide a quick time-to-market solution for sensor and control devices for Smart Home networks and for RF4CE/BLE Remote Control products.

Contact Information

For the latest specifications, additional product information, worldwide sales and distribution locations:

Web: www.qorvo.com

Tel: 1-844-890-8163

Email: lpw.support@qorvo.com

Important Notice

The information contained herein is believed to be reliable; however, Qorvo makes no warranties regarding the information contained herein and assumes no responsibility or liability whatsoever for the use of the information contained herein. All information contained herein is subject to change without notice. Customers should obtain and verify the latest relevant information before placing orders for Qorvo products. The information contained herein or any use of such information does not grant, explicitly or implicitly, to any party any patent rights, licenses, or any other intellectual property rights, whether with regard to such information itself or anything described by such information. **THIS INFORMATION DOES NOT CONSTITUTE A WARRANTY WITH RESPECT TO THE PRODUCTS DESCRIBED HEREIN, AND QORVO HEREBY DISCLAIMS ANY AND ALL WARRANTIES WITH RESPECT TO SUCH PRODUCTS WHETHER EXPRESS OR IMPLIED BY LAW, COURSE OF DEALING, COURSE OF PERFORMANCE, USAGE OF TRADE OR OTHERWISE, INCLUDING THE IMPLIED WARRANTIES OF MERCHANTABILITY AND FITNESS FOR A PARTICULAR PURPOSE.**

Without limiting the generality of the foregoing, Qorvo products are not warranted or authorized for use as critical components in medical, life-saving, or life-sustaining applications, or other applications where a failure would reasonably be expected to cause severe personal injury or death.

Copyright 2017 © Qorvo, Inc. | Qorvo is a registered trademark of Qorvo, Inc.