

GENERAL DESCRIPTION

The EV8048DQK-00A is the evaluation board for the MP8048, a configurable dual channel full-bridge or quad channel half-bridge.

The MP8048 features a low current shutdown mode, standby mode, input under voltage protection, current limit, thermal shutdown and fault flag signal output. Each full-bridge can be driven independently as stereo single ended audio amplifiers, or driven complementary in a bridge tied load (BTL) audio amplifier configuration. All channels of drivers interface with standard logic signals.

ELECTRICAL SPECIFICATIONS

Parameter	Symbol	Value	Units
Supply Voltage	V _{DD}	7.5 – 22	V
Peak Output Current	I _{PEAK}	4	A

FEATURES

- ±4A Peak Current Output
- Up to 600kHz Switching Frequency
- Protected Integrated Power 200mΩ Switches
- 30ns Switch Dead Time
- All Switches Current Limited
- Under Voltage Protection
- Thermal Protection
- 3.4mA Operation Current
- Fault Output Flag
- Single Ended Output Power: 8W/Channel, at 22V, 8Ω Load
- Bridge Tied Load Output Power: 30W/Channel, at 22V, 8Ω Load

APPLICATIONS

- Class D Audio Drivers

"MPS" and "The Future of Analog IC Technology" are Registered Trademarks of Monolithic Power Systems, Inc.

EV8048DQK-00A EVALUATION BOARD

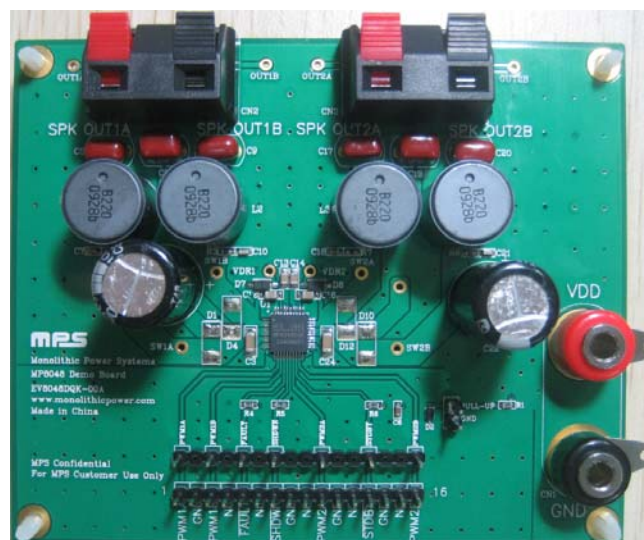

(L x W x H) 4.0" x 3.3" x 1.0"
(10.2cm x 8.4cm x 2.6cm)

Board Number	MPS IC Number
EV8048DQK-00A	MP8048DQK



EVALUATION BOARD SCHEMATIC

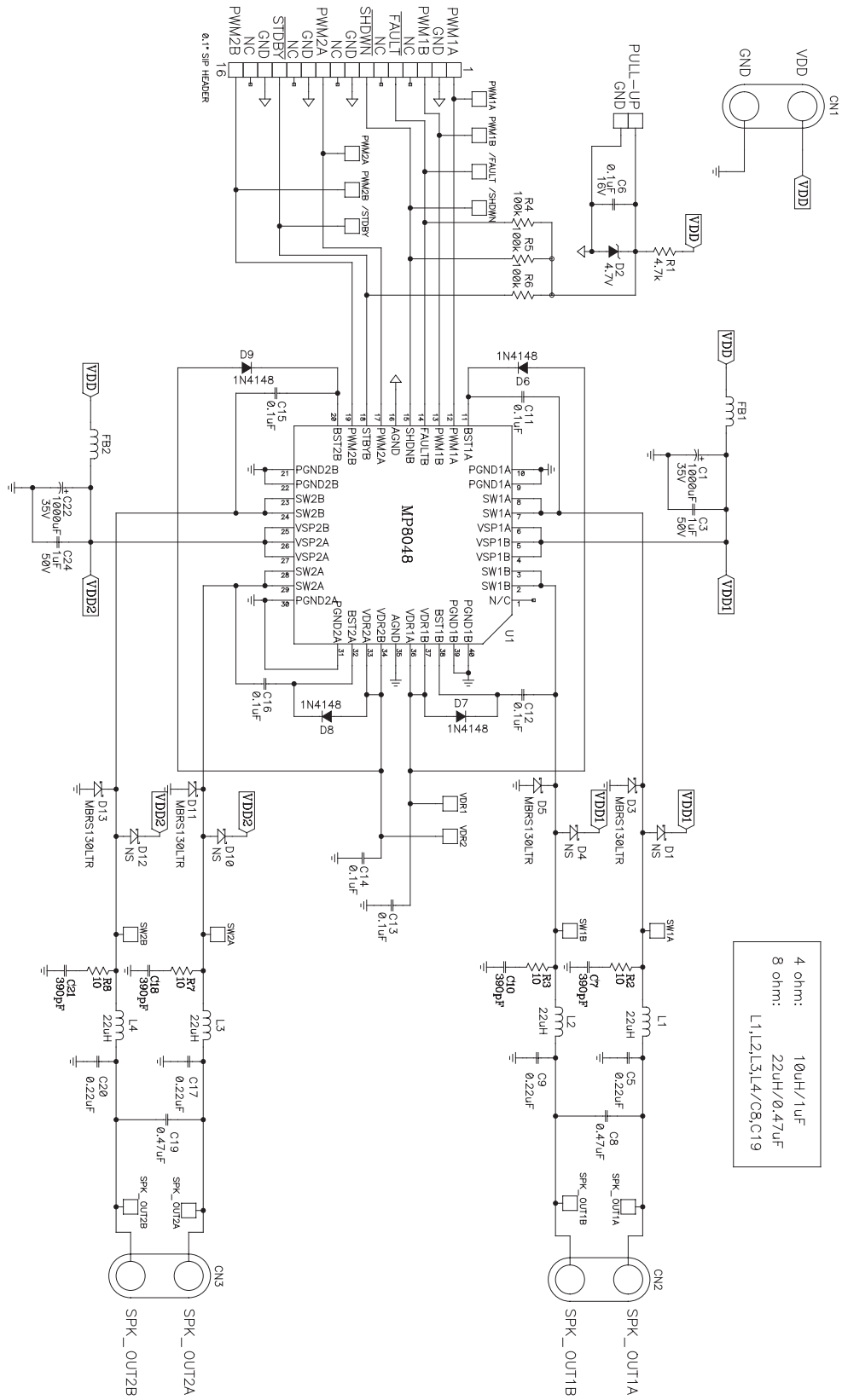

EV8048DQK-00A BILL OF MATERIALS

Qty	Ref	Value	Description	Package	Manufacturer	Manufacturer P/N
1	C6	0.1uF	Ceramic Capacitor, 50V, X7R	0603	muRata	GRM188R71H104KA93D
6	C11-16	0.1uF	Ceramic Capacitor, 50V, X7R	0805	muRata	GRM21BR71H104KA01L
2	C3, C24,	1uF	Ceramic Capacitor, 50V, X7R	1206	TDK	C3216X7R1H105K
4	C7, C10, C18, C21	390pF	Ceramic Capacitor, 50V, C0G	0603	muRata	GRM1885C1H391JA01D
2	C8, C19	0.47uF	CBB Capacitor, 50V	Radial	Panasonic	
4	C5, C9, C17, C20	0.22uF	CBB Capacitor, 50V	Radial	Panasonic	
2	C1, C22	1000uF	Electrolytic Cap, 35V	Radial	Rubycon	
1	R1	4.7kΩ	Film Res., 1%	0603	Yageo	RC0603FR-074K7L
4	R2, R3, R7, R8	10Ω	Film Res., 1%	0603	Yageo	RC0603FR-0710RL
3	R4, R5, R6	100kΩ	Film Res., 1%	0603	Yageo	RC0603FR-07100KL
4	L1, L2, L3, L4	22uH	3.29A	Radial	Toko	13RHBP-A7502BY-220M
4	D6, D7, D8, D9		Diode Switch, 40V, 0.5A	SOD-123	Diodes Inc.	B0540W
4	D1, D4, D10, D12	NS				
4	D3, D5, D11, D13		Diode Schottky, 40V, 1A	SMB	Diodes Inc.	B140B
1	D2		Diode Zener, 4.7V, 200mW	SOD-323	Diodes Inc.	BZT52C4V7S-7
2	FB1-2		Ferrite Bead, 6A	1206	LION	PB321611-320
1	U1		Class D Audio Amplifier		MPS	MP8048DQK
25			25-Pins Sip Header, 0.1"		any	
1	CN1		Banana Jacks, Red and Black		any	
2	CN2, CN3		PSTZ-2		any	

PRINTED CIRCUIT BOARD LAYOUT

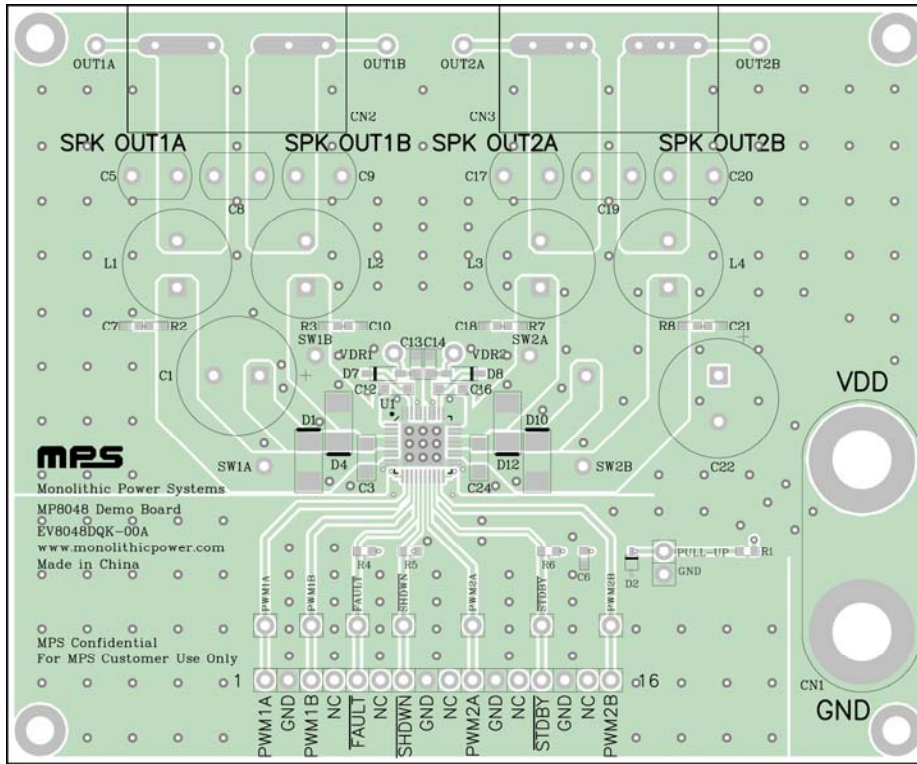

Figure 1—Top Silk Layer

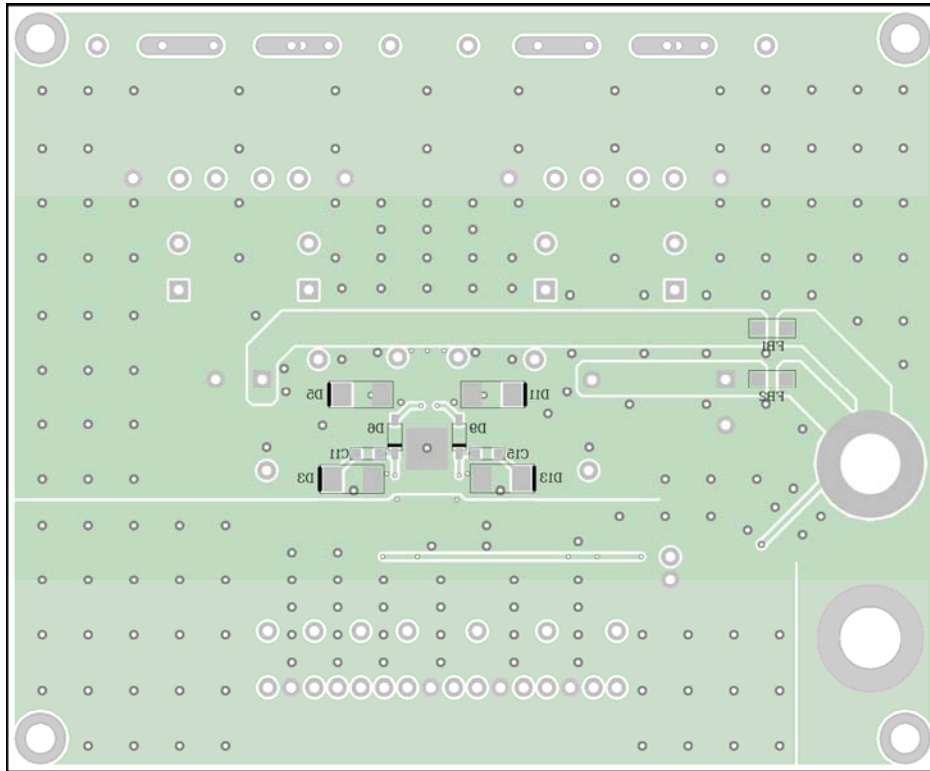

Figure 2— Bottom Silk Layer

QUICK START GUIDE

The EV8048DQK-00A comes pre-configured to operate as a stereo BTL (Bridge Tied Load) audio power driver, where a complementary PWM modulated audio signal (PWM and $\overline{\text{PWM}}$) is used for each channel, and the music is played to the speaker connected to the output. For BTL operation, follow the steps in the Quick Start Guide for BTL Operation section. For Single-Ended operation, make modifications and follow the steps as described in the Quick Start Guide for Single-Ended Operation section.

Quick Start Guide for Stereo BTL (Bridge-Tied Load) Operation

Input/Output Requirements

1. Power supply: 7.5V to 22V.
2. Stereo Complementary PWM Signal Source (PWM, $\overline{\text{PWM}}$).
3. Speaker Load: 8 Ω .

Setup Condition for Operation

4. Connect the speaker between SPK_OUT1A and SPK_OUT1B. Similarly, connect the speaker between SPK_OUT2A and SPK_OUT2B,
5. Connect the PWM signal source to PWM1A and the complementary signal source $\overline{\text{PWM}}$ to PWM1B, respectively. Use the GND terminal between PWM1A and PWM1B as the ground connection for the PWM inputs. Similarly, connect the complementary PWM signal of the other channel to PWM2A and PWM2B.
6. Apply power to the board.
7. Audio should be heard through the speakers.

Quick Start Guide for SE (Single-Ended) Operation

Input/Output Requirements

1. Power supply: 7.5V to 22V.
2. PWM Signal Source.
3. Two Speaker Loads: 4 Ω or 8 Ω .

Setup Condition for Operation

4. Take channel 1 (the full-bridge with output SW1A and SW1B) as an example. Remove C8 and connect the speakers as shown in Figure 3.
5. Connect the stereo PWM signal source to PWM1A and PWM1B, respectively. Use the GND terminals between PWM1A and PWM1B as the ground connections for the PWM inputs.
6. Apply power to the board.
7. Audio should be heard through the speakers.
8. The operation for channel 2 (the full-bridge with output SW2A and SW2B) is same.

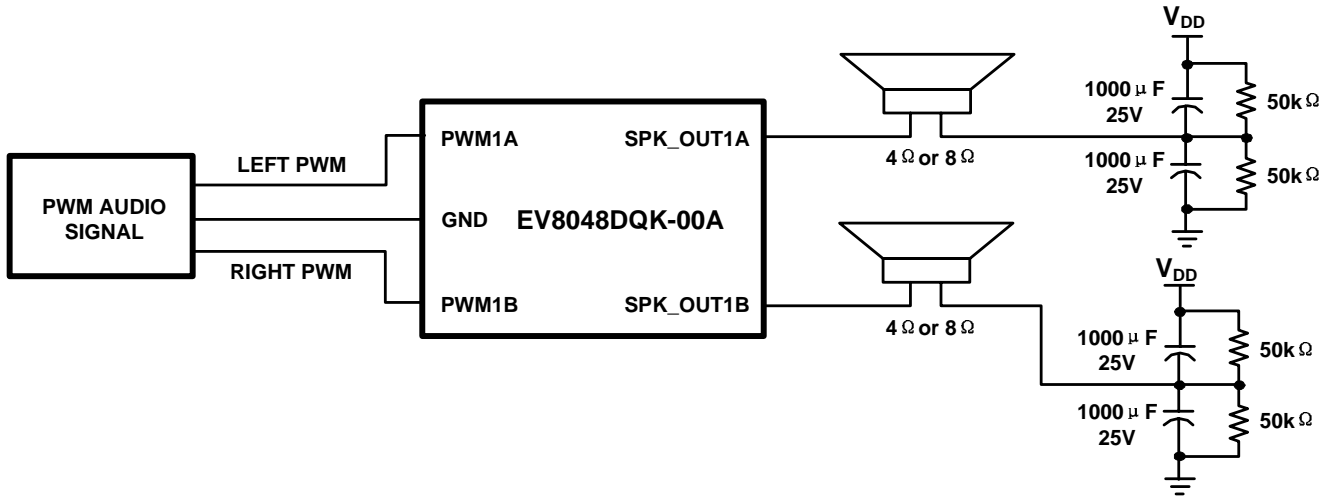

Figure 3—Setup for Single-Ended Operation (1 full-bridge only)

NOTICE: The information in this document is subject to change without notice. Please contact MPS for current specifications. Users should warrant and guarantee that third party Intellectual Property rights are not infringed upon when integrating MPS products into any application. MPS will not assume any legal responsibility for any said applications.