

VOLTAGE RANGE: 100 - 600V
CURRENT: 0.5 A

Features

- High current capability
- High surge current capability
- High reliability
- Low reverse current
- Low forward voltage drop
- Fast switching for high efficiency

Mechanical Data

- Case : DO-41 Molded plastic
- Epoxy : UL94V-O rate flame retardant
- Lead : Axial lead solderable per MIL-STD-202, Method 208 guaranteed
- Polarity : Color band denotes cathode end
- Mounting position : Any
- Weight : 0.339 gram

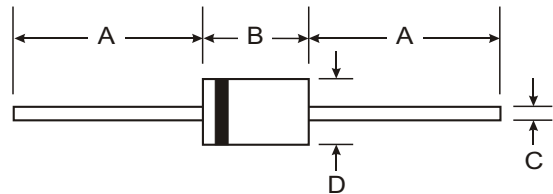
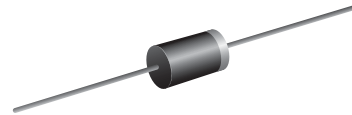

DO-41		
Dim	Min	Max
A	25.40	—
B	4.06	5.21
C	0.71	0.864
D	2.00	2.72
All Dimensions in mm		

Maximum Ratings and Electrical Characteristics T_A = 25°C unless otherwise specified

Single phase, half wave, 60Hz, resistive or inductive load. For capacitive load, derate current by 20%.

Characteristic	Symbol	S5295B	S5295G	S5295J	Unit
Maximum Repetitive Peak Reverse Voltage	V _{RRM}	100	400	600	V
Maximum Reverse Voltage (DC)	V _R	75	300	500	V
Maximum Average Forward Current	I _{F(AV)}	0.5			A
Maximum Peak One Cycle Surge Forward Current (50 Hz, Non-Repetitive)	I _{FSM}	30			A
Maximum Peak Forward Voltage at I _F = 1.0 A	V _F	1.5			V
Maximum Repetitive Peak Reverse Current at V _{RRM}	I _R	10			μA
Maximum Reverse Recovery Time (Note 1)	T _{rr}	1.5			μs
Junction Temperature Range	T _J	- 40 to + 125			°C
Storage Temperature Range	T _{STG}	- 40 to + 125			°C

Notes :

(1) Reverse Recovery Test Condition : I_F = 20 mA, I_R = 1mA

RATING AND CHARACTERISTIC CURVES (S5295B/G/J)

FIG.1 - REVERSE RECOVERY TIME CHARACTERISTIC AND TEST CIRCUIT DIAGRAM

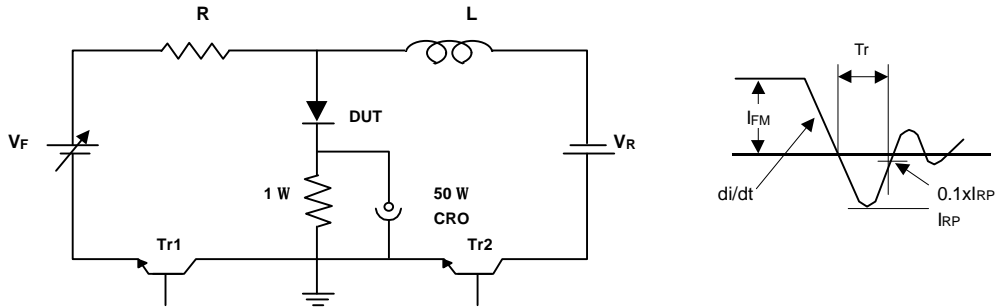

FIG.2 - DERATING CURVE FOR OUTPUT RECTIFIED CURRENT

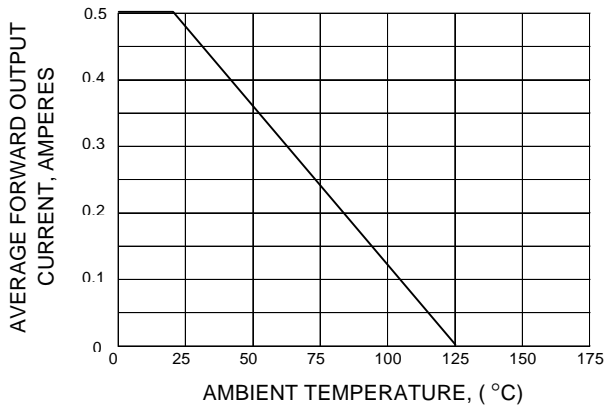

FIG.3 - MAXIMUM NON-REPETITIVE PEAK FORWARD SURGE CURRENT

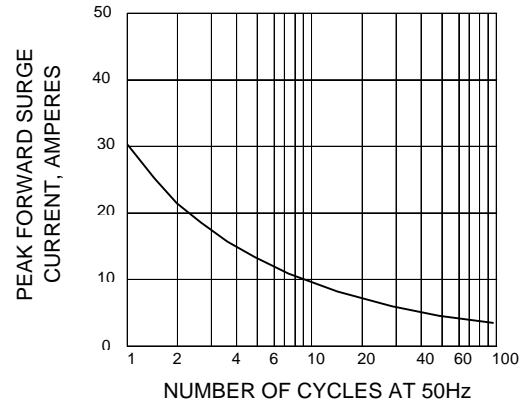

FIG.4 - TYPICAL FORWARD CHARACTERISTICS

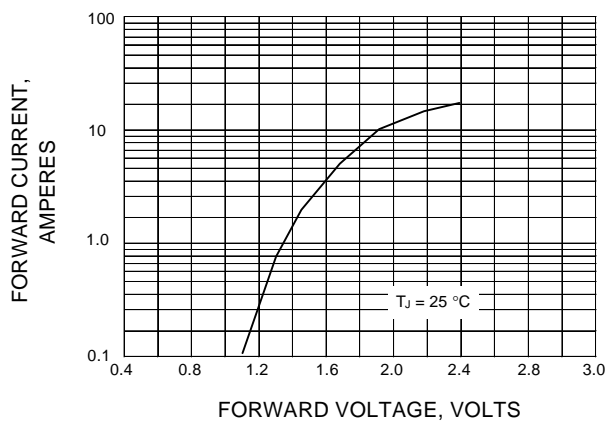

FIG.5 - TYPICAL REVERSE CHARACTERISTICS

