

R-1 Plastic-Encapsulate Diodes

High Efficient Rectifier

Features

- I_o 1A
- V_{RRM} 50V-1000V
- High surge current capability
- Polarity: Color band denotes cathode

Applications

- Rectifier

Marking

- 1HX
X: From 1 to 8

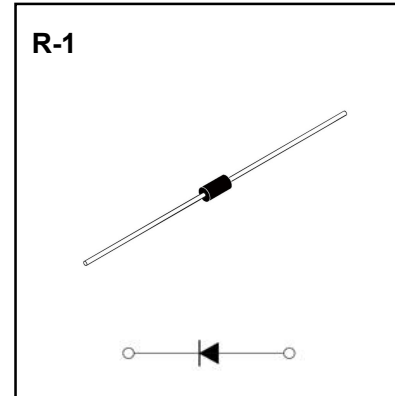

Limiting Values (Absolute Maximum Rating)

Item	Symbol	Unit	Conditions	1H1							
				1	2	3	4	5	6	7	8
Repetitive Peak Reverse Voltage	V_{RRM}	V		50	100	200	300	400	600	800	1000
Maximum RMS Voltage	V_{RMS}	V		35	70	140	210	280	420	560	700
Average Forward Current	$I_{F(AV)}$	A	60Hz Half-sine wave, Resistance load, $T_a=50^\circ\text{C}$	1.0							
Surge(Non-repetitive)Forward Current	I_{FSM}	A	60Hz Half-sine wave, 1 cycle, $T_a=25^\circ\text{C}$	30							
Junction Temperature	T_J	$^\circ\text{C}$		-55~+125							
Storage Temperature	T_{STG}	$^\circ\text{C}$		-55 ~ +150							

Electrical Characteristics ($T_a=25^\circ\text{C}$ Unless otherwise specified)

Item	Symbol	Unit	Test Condition	1H1							
				1	2	3	4	5	6	7	8
Peak Forward Voltage	V_{FM}	V	$I_{FM}=1.0\text{A}$	1.0		1.3		1.7			
Peak Reverse Current	I_{RRM1}	μA	$V_{RM}=V_{RRM}$	$T_a=25^\circ\text{C}$							
	I_{RRM2}			$T_a=125^\circ\text{C}$							
Reverse Recovery time	t_r	ns	$I_F=0.5\text{A}$ $I_R=1\text{A}$ $I_{RR}=0.25\text{A}$	50				75			
Thermal Resistance(Typical)	$R_{\theta J-A}$	$^\circ\text{C}/\text{W}$	Between junction and ambient	50							

Typical Characteristics

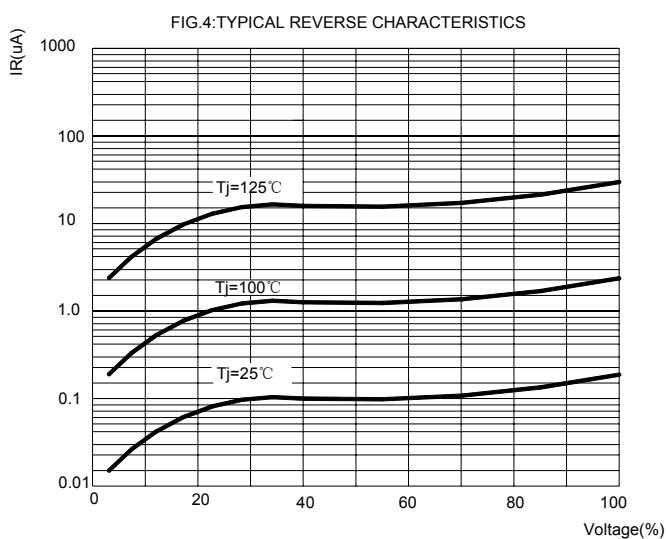
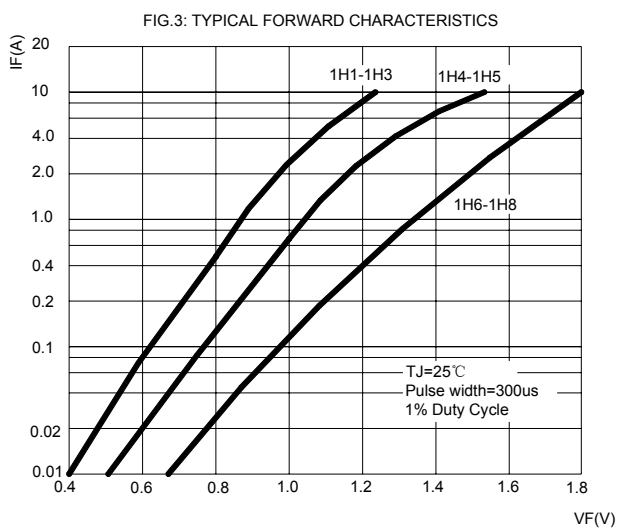
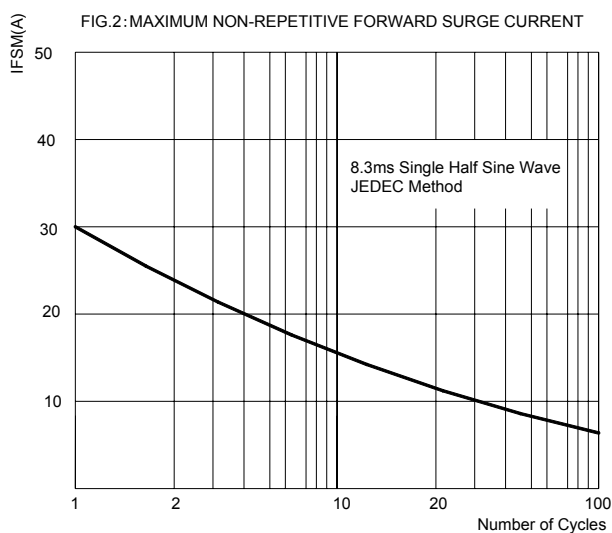
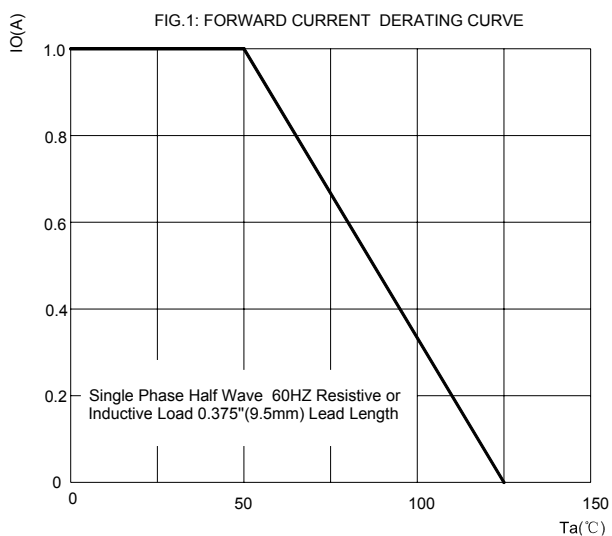
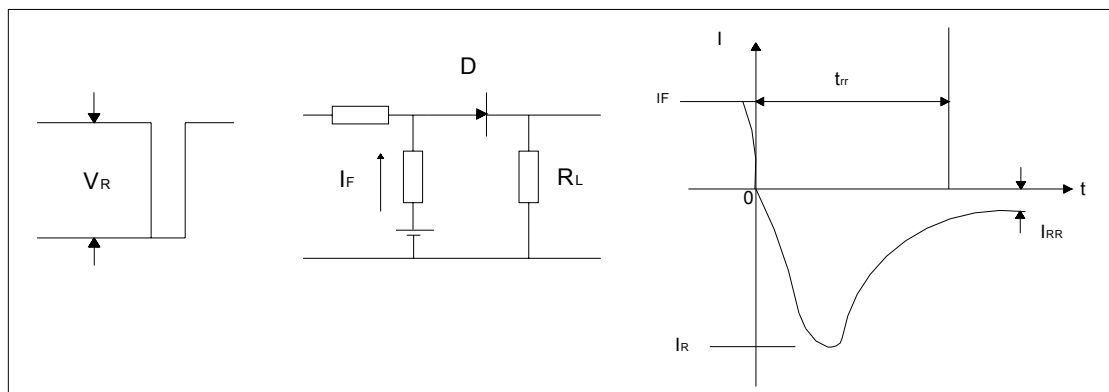
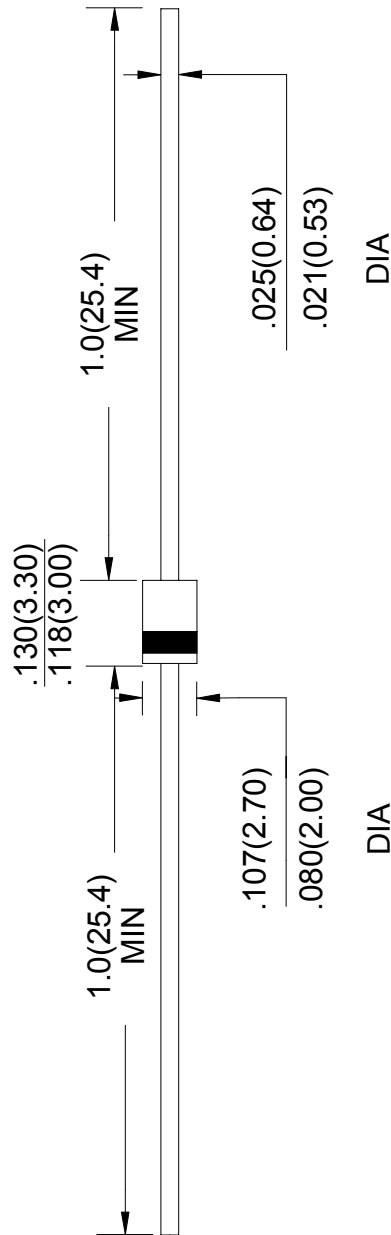

FIG.5: Diagram of circuit and Testing wave form of reverse recovery time



R-1 Package Outline Dimensions



Unit: in inches (millimeters)

NOTICE

JSKD reserve the right to make modifications, enhancements, improvements, corrections or other changes without further notice to any product herein. JSKD does not assume any liability arising out of the application or use of any product described herein.

Ammo Box Packaging Specifications For Axial Lead Rectifiers

Axial lead devices are packed in accordance with EIA standard RS-296-D and specifications given below

COMPONENT OUTLINE	COMPONENT PITCH A	INNER TAPE PITCH B	CUMULATIVE PITCH TOLERANCE
	$\pm 0.5\text{mm}(.020'')$	$+0.5\text{mm}(.020'')$	
R-1	5.0mm	26.0mm	2.0mm/20pitch
R-1	5.0mm	52.4mm	2.0mm/10pitch
A-405	5.0mm	26.0mm	2.0mm/20pitch
A-405	5.0mm	52.4mm	2.0mm/10pitch
DO-34/DO-35	5.0mm	26.0mm	2.0mm/20pitch
DO-34/DO-35	5.0mm	52.4mm	2.0mm/10pitch
DO-41	5.0mm	26.0mm	2.0mm/20pitch
DO-41	5.0mm	52.4mm	2.0mm/10pitch
DO-15	5.0mm	52.4mm	2.0mm/10pitch
DO-27	10.0mm	52.4mm	2.0mm/10pitch
R-6	10.0mm	52.4mm	2.0mm/10pitch

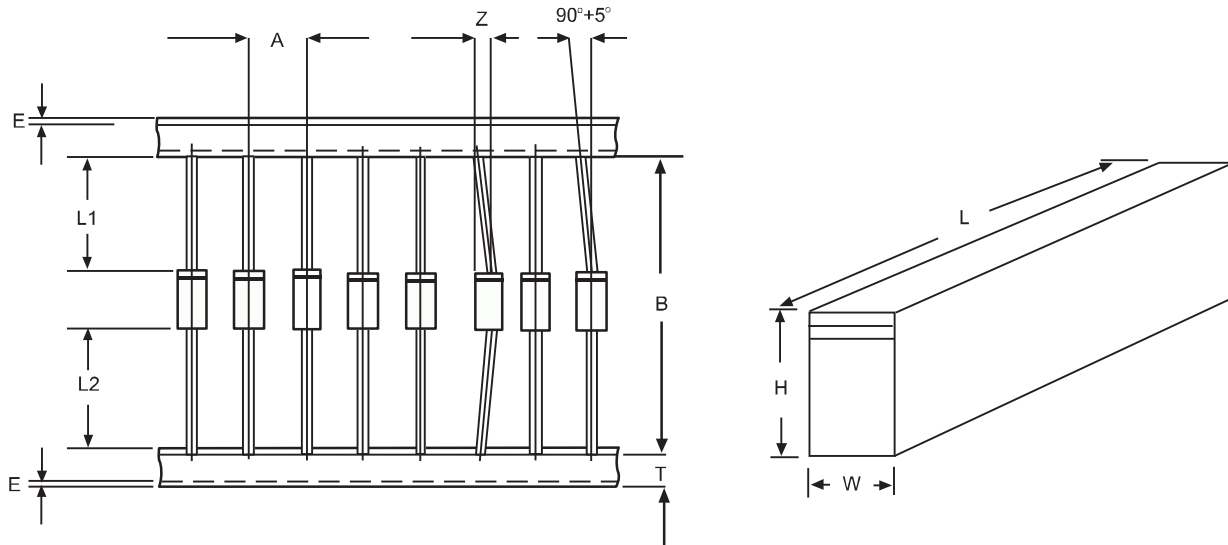

ITEM	SYMBOL	SPECIFICATIONS(mm)	SPECIFICATIONS(inch)
Component alignment	Z	1.2max	0.048max
Tape width	T	6.0 ± 0.4	0.236 ± 0.016
Exposed adhesive	E	0.8max	0.032max
Body eccentricity	$ L1-L2 $	1.0max	0.040max
Box length	L	255.0 ± 5.0	10.04 ± 0.197
Box width	W	78.0 ± 5.0	3.07 ± 0.197
Box height	H	150.0 ± 5.0	5.91 ± 0.197

NOTE: Each component lead shall be sandwiched between tapes for A minimum of 3.2mm(0.126'')