

# SEP191404A

- External Shape Type : 3.5 × 2.8 Flat View LED
- Color : Orange
- Application : Automotive, Consumer Electronics, Office Automation, Indicator
- Feature : MSL-3, RoHS compliant,  
Compatible with heat-resistance of lead-free solder.

## ● Absolute maximum ratings

Description	Symbol	Ratings	Unit	Remark
Power dissipation	PD	91	mW	
Forward current	IF	35	mA	
Forward current reduction	$\Delta$ IF	-1.0	mA/°C	Above 85°C
Pulse forward current	IFP	100	mA	f=1kHz tw ≤ 100μs
Reverse Voltage	VR	3	V	
Operating temperature	Topr	-40~100	°C	
Storage temperature	Tstg	-40~100	°C	
Junction Temperature	Tjmax	115	°C	

## ● Photoelectric characteristic (Ta=25°C)

Description	Symbol	Conditions	Min	Typ	Max	Unit
Forward voltage	VF	IF = 20mA		2.1	2.5	V
Reverse current	IR	VR=3V			10	μA
Luminous intensity	IV	IF = 20mA	493	620	775	mcd
Dominant Wavelength	$\lambda_d$	IF = 20mA		591		nm
Thermal resistance	$\theta_{j-a}$			150		°C/W

## ● Luminous intensity rank (Ta=25°C)

(tolerances: ± 10%)

rank	Luminous intensity range(mcd)		
D	493	~	620
E	620	~	775

## ● Dominant wavelength rank (Ta=25°C)

(tolerances: ± 1nm)

rank	Dominant wavelength range(nm)		
Y	588	~	591
R	591	~	594

● Characteristic data

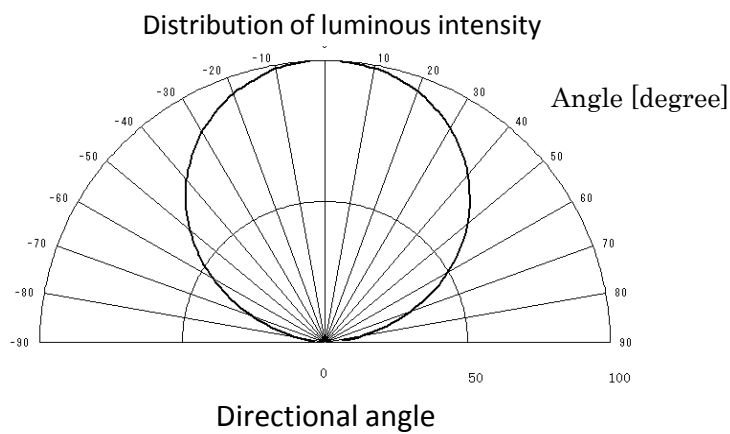
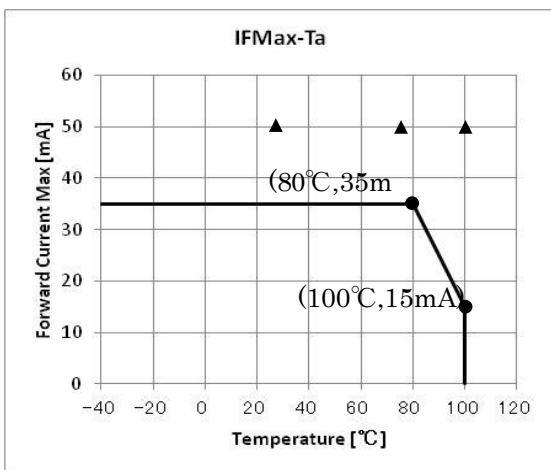
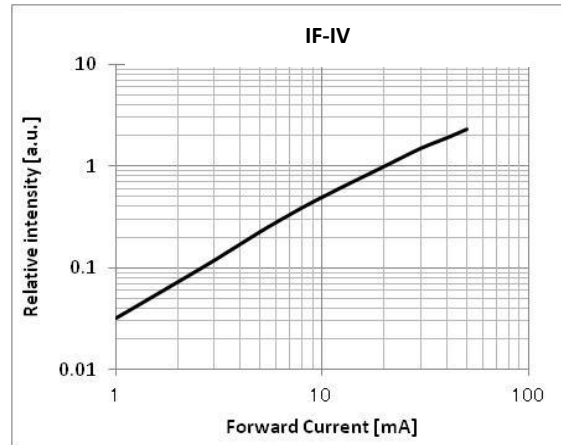
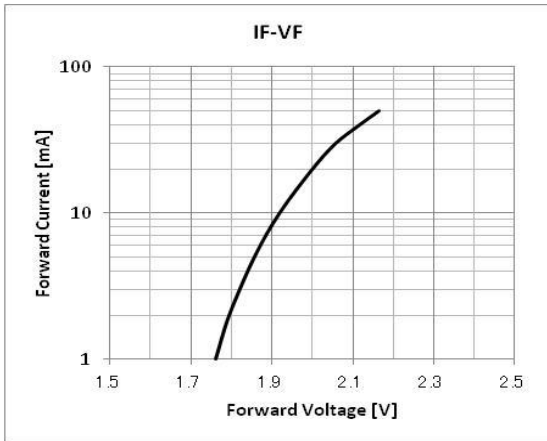

● Outline

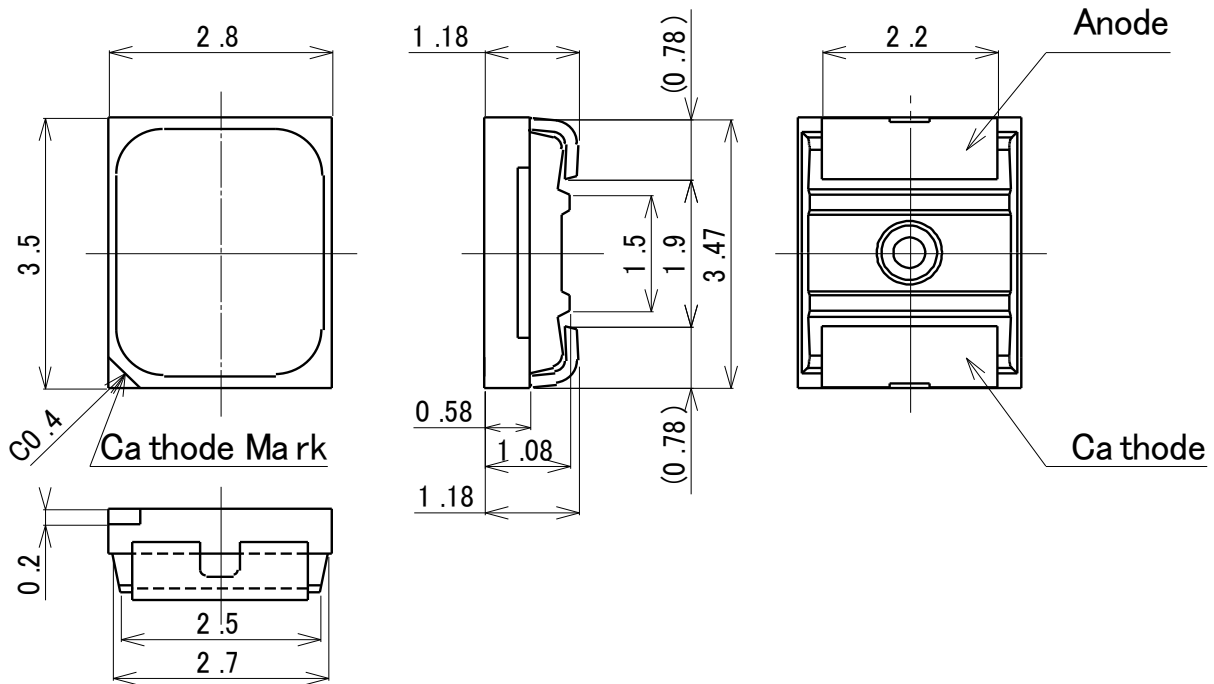

Recommendable soldering pattern (For reflow soldering)

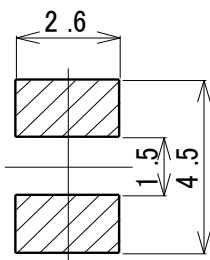

Tolerance  $\pm 0.2$

Material & Finish of leads

Material	Copper-Iron Alloy
Finish	Ag plating

Material of resin

Material	Silicone
----------	----------

**● Soldering conditions**

Following soldering conditions are recommended.

**① Reflow conditions (at the surface of LED resin)**

Pre-heat : 150 ~ 180 °C、60 ~ 120 sec

Soldering temperature: Soldering time more than 220°C is less than 40 sec.

Peak temperature is should be is less than 260°C.

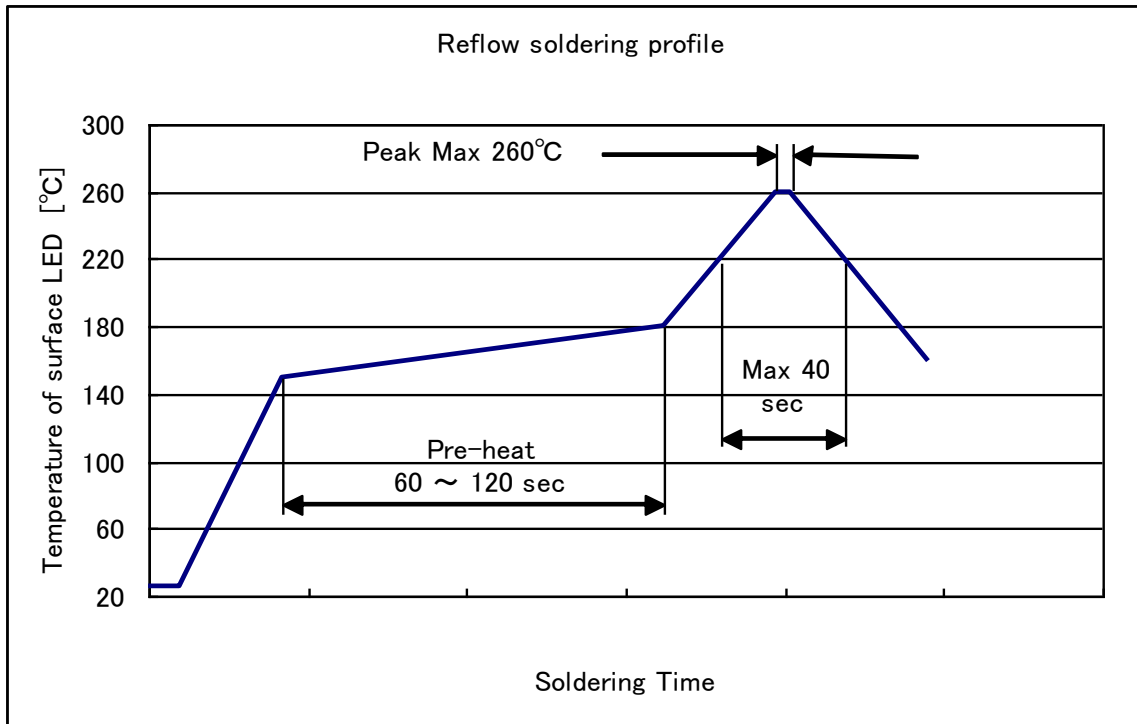
**② Manual soldering**

Temperature of soldering iron tip should be  $350 \pm 10^{\circ}\text{C}$  for 3 seconds, which shall apply to only one soldered point and once for the each soldered point.

## ● Attention after opened

The LED is in SMD package. When the LED is mounted by means of soldering and the resin is unusually damp, soldering may cause interfacial defoliation.

This occurs when a drastic temperature change causes moisture in the resin to evaporate and to swell. Therefore, attention to the below must be paid.

### ① Atmosphere when using the LEDs after package is opened

After opened and mounted, soldering should be carried out quickly.

Following atmosphere is recommended when using (and mounting) the LEDs.

Temperature : 5~30°C    Humidity : less than 70%

### ② Baking

In case 168 hours have passed after package is opened, LEDs must be dried as follows.

60±5 °C for more than 24 hours (taping reel)

### ③ Storage after package is opened

Following storage conditions are recommended after package is opened.

In case indicator color (blue) of desiccant (ex. silica gel) has disappeared, LEDs must be dried under the same conditions as ② above.

## ● Other

① After soldering any mechanical force or excessive vibration should not be applied to LEDs during cooling process until the LEDs cool down to normal temperature.

② Quick cooling must be avoided.

③ The LEDs should not be mounted on warped direction of PCB.

④ This product series emits high light power. Do not look directly into the light emitting area. Direct exposure to the light over an extended time period may harm eyes.

⑤ Extra attention should be paid to the sealing resin of the product, which is silicone resin.

- The emitting area of the LEDs contains fine gold wires. Touching this area without care may add excess stress on the internal gold wires and may result in
- The silver plating of the leadframe may discolor if the product comes into contact with material containing sulfides or if it is exposed to an atmosphere containing sulfide gas.

## ● Reliability test

	Test Items	EIAJ ED-4701	Test Conditions
Life Tests	Steady state operating life	-	Ta=RT, Ifmax t=1000h
Environmental Tests	High temperature storage	201	Ta=Tstgmax t=1000h
	Low temperature storage	202	Ta=Tstgmin t=1000h
	Moisture Resistance	103	Ta=60±5°C, RH=90±5% t=1000h
	Temperature cycle	105	Tstgmin(30min)~Tstgmax(30min) 100cycles
	Soldering heat	301	T=260±5°C, t=10s, 1time
	Solderability	402	T=245±5°C, t=5±1s, 1time, Using flux for Pb free solder
	Drop	-	H=1m, Drop on maple board, 10times

## Measurement Item and Criterion Judge Failure

No	Measurement Item	Mark	Criterion Judge Failure
1	Forward Voltage	VF	$OK \leq V.F.S. \times \pm 20\%$
2	Luminous Intensity	Iv	$OK \geq I.V.S. \times 0.5$

\*Solderability ... The Lead shall be covered by solder at least 95%.

Measurement conditions is based on specifications.

Tstgmax and Tstgmin is absolute maximum ratings.

Ifmax and IFPmax is absolute maximum ratings.

U.S.L. is upper limit of standard.

V.F.S. is Initial data of VF.

I.V.S. is Initial data of Luminous Intensity.

● Packing

Packing Material : Aluminum laminated moisture-proof packing

Quantity : 2000 pcs (Minimum order quantity)

Label : See below.

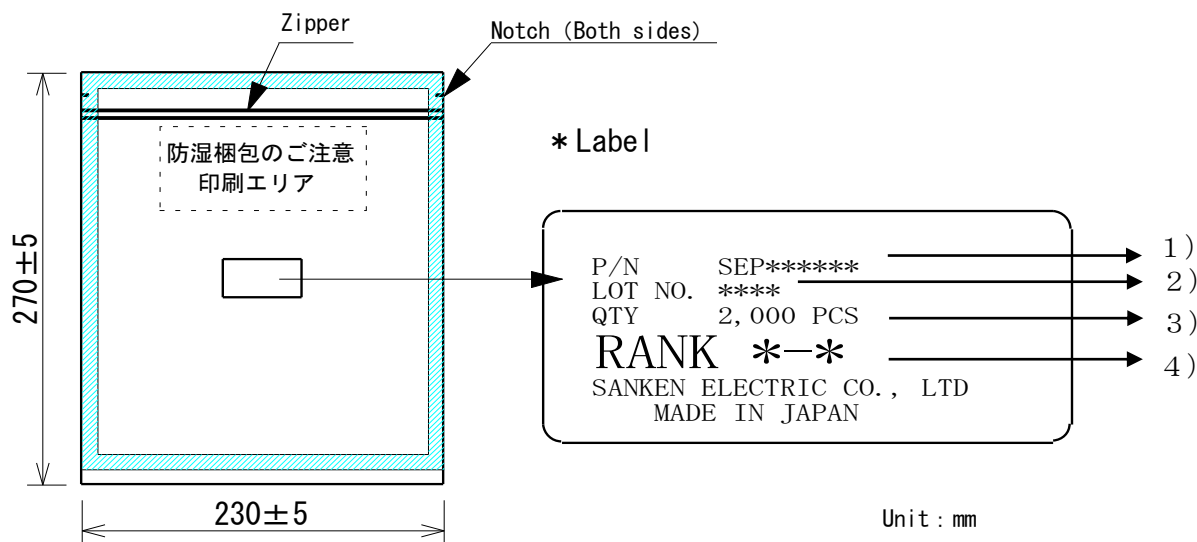

1) Part Number : SEP\*\*\*\*\*

2) Lot No. : \* \* \* \*  
                  ↑ ↑ ↑  
                  ① ② ③

① Last digit of year、

② Month

(January~September→Arabic Numeral

October →O、November→N、December→D)

③ Day

3) quantity : 2000pcs

4) Rank : \* - \*  
                  ↑ ↑  
                  ① ②

① Luminous intensity rank

② Chromaticity rank

● Taping reel dimensions

Unit:mm

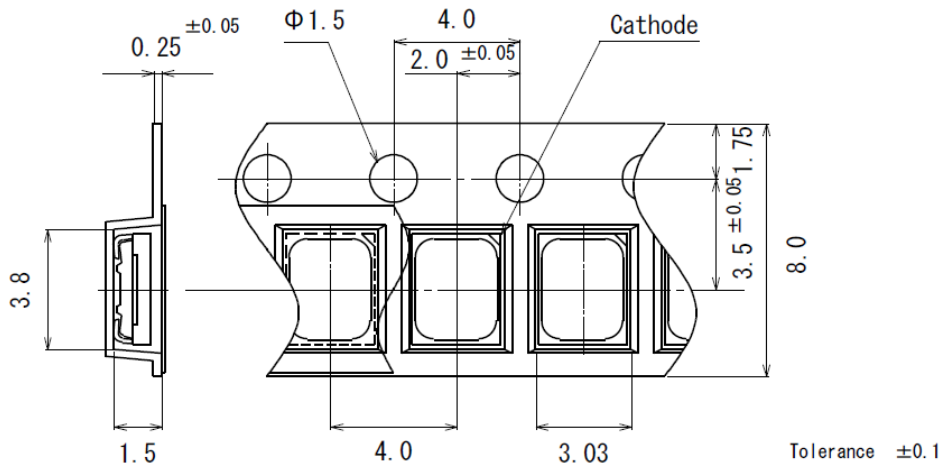

Taping reel dimensions

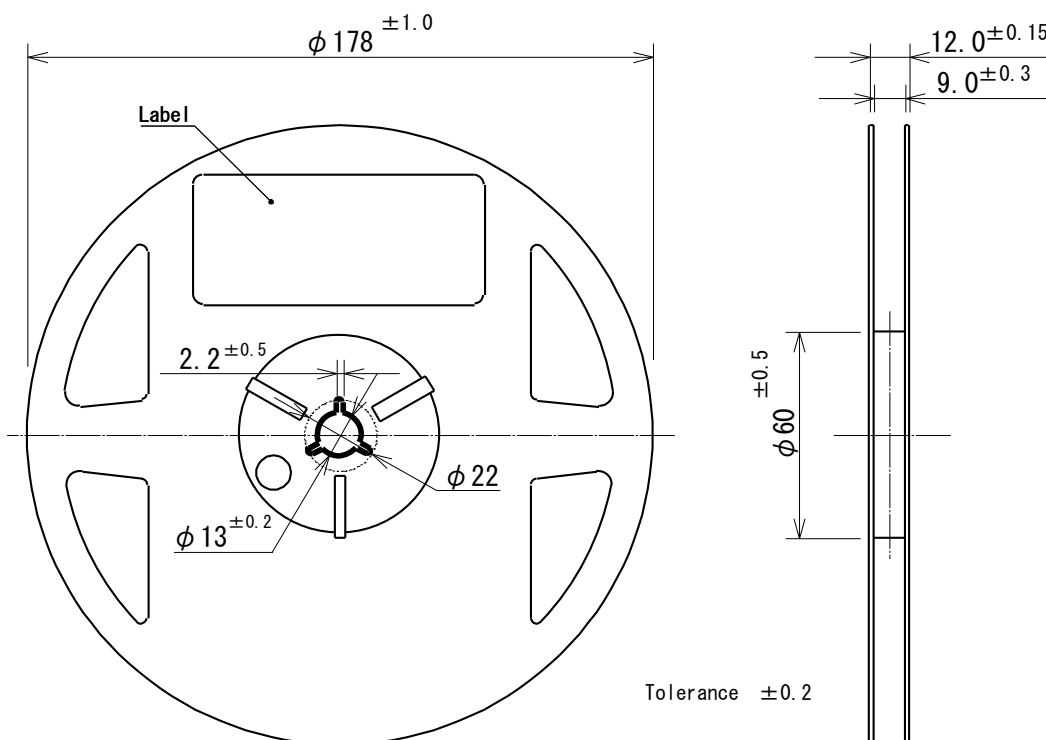

①Quantity

The quantity per reel shall be 2000 pcs.

②Cumulative tolerance

Cumulative tolerance per 10 pitches shall be  $\pm 0.2$ mm.

③Adhesion strength of cover tape

Adhesion strength to be 0.1-0.7N when the cover tape is turn off from the carrier tape at 10 angle to be carrier tape.

④Packaging

P/N, manufacturing date code number and quantity shall be indicated on a dampproof package.



## ● Tips

- The contents written in this data sheet may be changed without a preliminary announcement by improvement etc. When you use it, please check that information is the newest and conclude specifications.
- Application and operation examples described in this publication are quoted for the sole purpose of reference for the use of the products herein and SanKen can assume no responsibility for any infringement of industrial property rights, intellectual property rights or any other rights of SanKen or any third party which may result from its use.
- When using the products specified herein by either combining other products or materials therewith or physically, chemically or otherwise processing or treating the products, please duly consider all possible risks that may result from all such uses in advance and proceed therewith at your own responsibility.
- Although SanKen undertakes to enhance the quality and reliability of its products, the occurrence of failure and defect of semiconductor products at a certain rate is inevitable.  
Users of SanKen products are requested to take, at their own risk, preventative measures including safety design of the equipment or systems against any possible injury, death, fires or damages to the society due to device failure or malfunction.
- SanKen products listed herein are intended for use as components of general purpose electronic equipment or apparatus (such as home appliances, office equipment, telecommunication equipment, measuring equipment, etc.). Prior to use of the SanKen Products, please put your signature, or affix your name and seal, on the specification documents of the SanKen Products and return them to SanKen. When considering use of the SanKen Products for any applications that require higher reliability (such as transportation equipment and its control systems, traffic signal control systems or equipment, disaster/crime alarm systems, various safety devices, etc.), you must contact a SanKen sales representative to discuss the suitability of such use and put your signature, or affix your name and seal, on the specification documents of the SanKen Products and return them to SanKen, prior to the use of the SanKen Products. The SanKen Products are not intended for use in any applications that require extremely high reliability such as: aerospace equipment; nuclear power control systems; and medical equipment or systems, whose failure or malfunction may result in death or serious injury to people, i.e., medical devices in Class III or a higher class as defined by relevant laws of Japan (collectively, the “Specific Applications”). SanKen assumes no liability or responsibility whatsoever for any and all damages and losses that may be suffered by you, users or any third party, resulting from the use of the SanKen Products in the Specific Applications or in manner not in compliance with the instructions set forth herein.
- Anti radioactive ray design is not considered for the products listed herein.
- SanKen assumes no responsibility for any troubles, such as dropping products caused during transportation out of SanKen’s distribution network.