

# Surface Mount Power Splitter/Combiner

2 Way-90° 50Ω 65 to 75 MHz

LRPQ-70J



CASE STYLE: QQQ569

## Maximum Ratings

Operating Temperature	-40°C to 85°C
Storage Temperature	-55°C to 100°C
Power Input (as a splitter)	1W max.

Permanent damage may occur if any of these limits are exceeded.

## Pin Connections

SUM PORT	6
PORT 1 (0°)	4
PORT 2 (+90°)	1
GROUND	2,5
50 OHM TERM EXTERNAL	3

## Outline Drawing

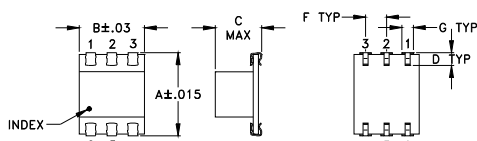

### PCB Land Pattern

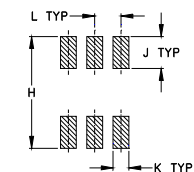

Suggested Layout,  
Tolerance to be within ±.002

## Outline Dimensions (inch/mm)

A	B	C	D	E	F	G	
.390	.31	.225	.060	--	.100	.045	
9.91	7.87	5.72	1.52	--	2.54	1.14	
H	J	K	L	M			wt
.420	.120	.060	.100	--			grams
10.67	3.05	1.52	2.54	--			0.50

## Demo Board MCL P/N: TB-226 Suggested PCB Layout (PL-140)

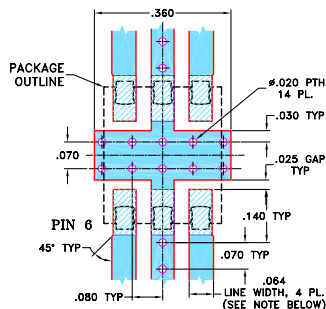

- NOTE:**
- TRACE WIDTH IS SHOWN FOR ROGERS RO4350B WITH DIELECTRIC THICKNESS .030" ± .002"; COPPER: 1/2 OZ. EACH SIDE. FOR OTHER MATERIALS TRACE WIDTH MAY NEED TO BE MODIFIED.
  - BOTTOM SIDE OF THE PCB IS CONTINUOUS GROUND PLANE.
- DENOTES PCB COPPER LAYOUT WITH SMOBC (SOLDER MASK OVER BARE COPPER)  
 DENOTES COPPER LAND PATTERN FREE OF SOLDER MASK

### Notes

- Performance and quality attributes and conditions not expressly stated in this specification document are intended to be excluded and do not form a part of this specification document.
- Electrical specifications and performance data contained in this specification document are based on Mini-Circuit's applicable established test performance criteria and measurement instructions.
- The parts covered by this specification document are subject to Mini-Circuits standard limited warranty and terms and conditions (collectively, "Standard Terms"); Purchasers of this part are entitled to the rights and benefits contained therein. For a full statement of the Standard Terms and the exclusive rights and remedies thereunder, please visit Mini-Circuits' website at [www.minicircuits.com/MCLStore/terms.jsp](http://www.minicircuits.com/MCLStore/terms.jsp)

## Features

- low insertion loss, 0.1 dB typ.
- high isolation, 30 dB typ.
- excellent phase unbalance 1 deg. typ.
- excellent return loss, VSWR 1.12:1 typ.
- aqueous washable

## Applications

- VHF
- instrumentation
- modulators
- balanced amplifiers

## Electrical Specifications

FREQ. RANGE (MHz)	ISOLATION (dB)	INSERTION LOSS (dB) Avg. of Coupled Outputs ABOVE 3 dB	PHASE UNBALANCE (Degrees)	AMPLITUDE UNBALANCE (dB)
$f_L$ - $f_U$	Typ. Min.	Typ. Max.	Max.	Max.
65-75	30 20	0.1 0.5	3	1.0

LRPQ units have bottom barrier ground plane insulated with glass barrier.

## Typical Performance Data

Frequency (MHz)	Total Loss <sup>1</sup> (dB)		Amplitude Unbalance (dB)	Isolation (dB)	Phase Unbalance (deg.)	VSWR S	VSWR 1	VSWR 2
	S-1	S-2						
65.00	2.78	3.45	0.68	29.08	90.74	1.12	1.11	1.06
65.50	2.81	3.42	0.61	29.00	90.74	1.12	1.11	1.06
66.00	2.84	3.38	0.54	28.95	90.73	1.12	1.11	1.06
66.75	2.88	3.34	0.45	28.81	90.69	1.12	1.11	1.06
67.50	2.94	3.29	0.35	28.73	90.72	1.12	1.11	1.06
68.25	2.98	3.25	0.27	28.60	90.75	1.12	1.11	1.06
69.00	3.02	3.20	0.18	28.52	90.78	1.12	1.11	1.06
69.75	3.07	3.15	0.09	28.40	90.78	1.12	1.11	1.06
70.50	3.10	3.10	0.00	28.32	90.81	1.12	1.11	1.06
71.25	3.15	3.07	0.08	28.21	90.77	1.12	1.11	1.06
72.00	3.19	3.02	0.17	28.13	90.79	1.12	1.11	1.06
73.00	3.25	2.97	0.29	27.99	90.82	1.12	1.11	1.06
74.00	3.30	2.91	0.39	27.87	90.86	1.12	1.11	1.06
74.50	3.33	2.89	0.45	27.83	90.84	1.12	1.11	1.06
75.00	3.36	2.86	0.50	27.76	90.86	1.12	1.11	1.06

1. Total Loss = Insertion Loss + 3dB splitter loss.

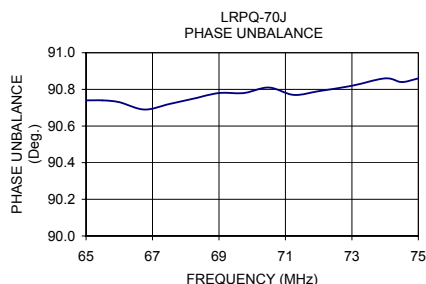
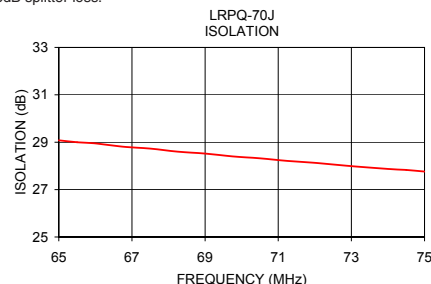
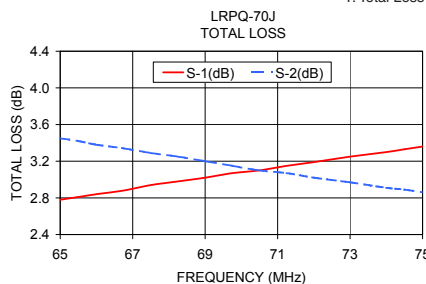

## electrical schematic

