

IMPEDANCE (Z)			
Frequency	25 MHz	100 MHz	300 MHz
Nominal (REF)	80 Ω	240 Ω	630 Ω
Minimum	- Ω	192 Ω	- Ω

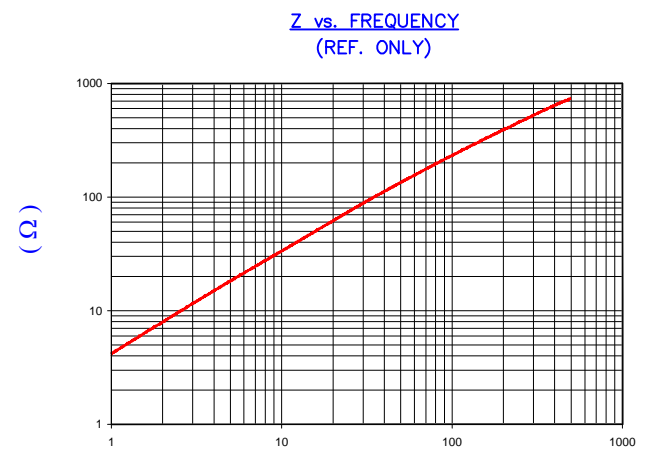

Z vs. FREQUENCY (REF. ONLY)
 AGILENT E4991A Impedance/Material Analyzer
 HP 16092A-Test Fixture

UNCONTROLLED DOCUMENT

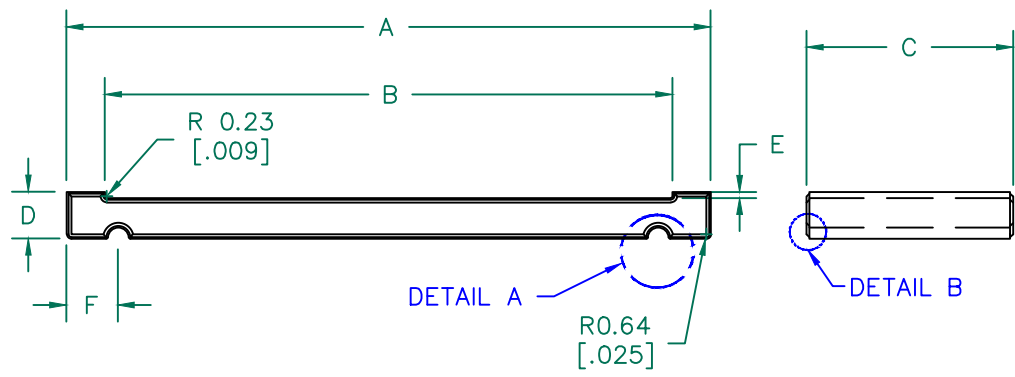
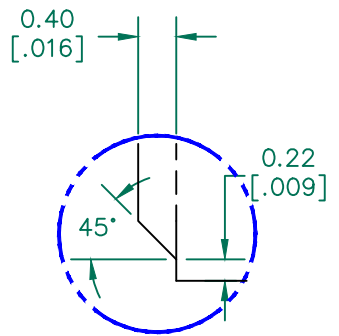
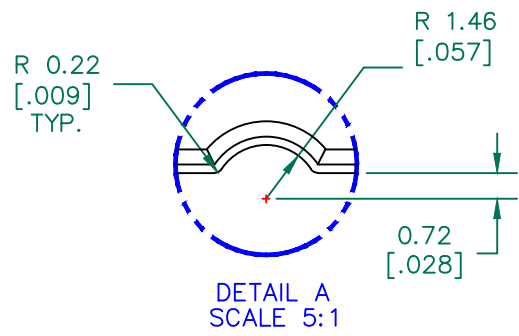

FERRITE CORE DIMENSIONS (SPEC): mm [in]

A	88.90 [3.500]	+	1.78 [.070]
B	78.23 [3.080]	+	1.52 [.060]
C	28.58 [1.125]	+	0.76 [.030]
D	6.48 [.255]	+	0.25 [.010]
E	0.84 [.033]	+	0.25 [.010]
F	7.62 [.300]	+	0.05 [.002]

WEIGHT/1000 70.97 kgs 156.47 Lbs

NOTES: UNLESS OTHERWISE SPECIFIED

1. COSMETIC SPECIFICATION REFER TO WI-QA-038.
2. ADD METAL CLIPS FOR SHIPPING P/N ASSE017-2.

DIMENSIONS ARE IN mm [INCHES].				This print is the property of Laird Tech. and is loaned in confidence subject to return upon request and with the understanding that no copies shall be made without the written consent of Laird Tech. All rights to design or invention are reserved.				
REV	DESCRIPTION	DATE	INT					
G	CHANGE F DIMENSION	11/24/09	Jcai	PROJECT/PART NUMBER: 28S2012-0M0		REV G	PART TYPE: FERRITE SPLIT RIBBON	DRAWN BY: JBE
F	UPDATE PRINT FORMAT & Z SPECS ADD CURVE, REM SCALE DWG	07/08/03	JRK	DATE: 11/30/94		SCALE: -	MATERIAL: FERRITE	
E	COR PART WGT, REM NOTES 1 & 3	09/12/02	JRK	CAD # 28S2012-0M0-G		TOOL # S2012		
D	REACTIVATE PRINT, UPDATE PRINT FORMAT AND DIMENSIONSE, REVISE Z SPECS	10/24/01	TMB					
C	UPDATE P/N FOR NEW CATALOG	11/13/95	JBE					
B	CHANGE TO METAL CLIPS	11/30/94	JBE					
A	ORIGINAL DRAFT	11/30/94	JBE					
REV	DESCRIPTION	DATE	INT					