

## Product Features

- Small size (4 x 4 mm)
- High gain
- High linearity
- Low cost
- Low Noise Figure
- 30dB AGC Range
- Pb-free/RoHS compliant

## Applications

- FTTH (G-PON, GE-PON)
- Optical node
- RFoG



Package Type : QFN4X4

## Description

ACQ629 is designed as low cost Trans-impedance amplifiers for many applications including FTTH, RFoG, Optical, Triplexers. This MMIC is based on Gallium Arsenide Enhancement Mode pHEMT which shows low current draw and very low noise. The data in this spec sheet is valid only for 75ohm RF Video output application.

## Electrical Specifications

PARAMETER		UNIT	MIN	TYP	MAX	CONDITION
Frequency		MHz	50	-	1000	-
Gain		dB	-	37.5	-	ACQ629 + AGC Insertion Loss 2dB AGC Vctr = 10.0V
Gain Flatness		dB	-	1	-	
Input Return Loss		dB	-	-15	-10	
Output Return Loss		dB	-	-12	-8	
Output IP3		dBm	30	36	-	
1dB Compression Point		dBm	19	22	-	
Noise Figure		dB	-	2	4	
AGC Range $\pi$ Pin Diode (SMP1307-027)		dB	-	30	-	Vctr = 0V ~ 10V
CSO	50 ~ 870MHz	dBc	-	-60	-55	135 channel FLAT +30dBmV/ch
CTB		dBc	-	-65	-60	
XMOD		dBc	-	-60	-55	
CSO	50 ~ 870MHz	dBc	-	-70	-65	135 channel FLAT +20dBmV/ch
CTB		dBc	-	-80	-75	
XMOD		dBc	-	-75	-70	
ACQ629 DC Current		mA	-	130	-	VDD = +12.0V
AGC DC Current		mA	-	30	-	AGC Vctr = 10.0V

### Note

1. Test conditions unless otherwise noted. Test Freq = 500MHz, T=25°C, VDD=5V, 75Ω system
2. OIP3 measured with 2 tones at an output power of +5dBm/tone separated by 1MHz

Absolute Maximum Ratings

PARAMETER	UNIT	MIN	TYP	MAX	CONDITION
Device Voltage	V <sub>DC</sub>	-	12	14	-
Operating Temperature	°C	-40	-	85	-
Storage Temperature	°C	-40	-	150	-
ESD Human Body Model	-	-	Class 0	-	-
Moisture Sensitivity Level	-	-	MSL1	-	-
Junction Temperature	°C	-	-	180	-
Thermal Resistance (R <sub>th</sub> )	°C/W	-	30	-	-

Application Circuit @ 50 ~ 1000MHz, 75ohm System

\* Bias of the same color can be configured as the Common Bias

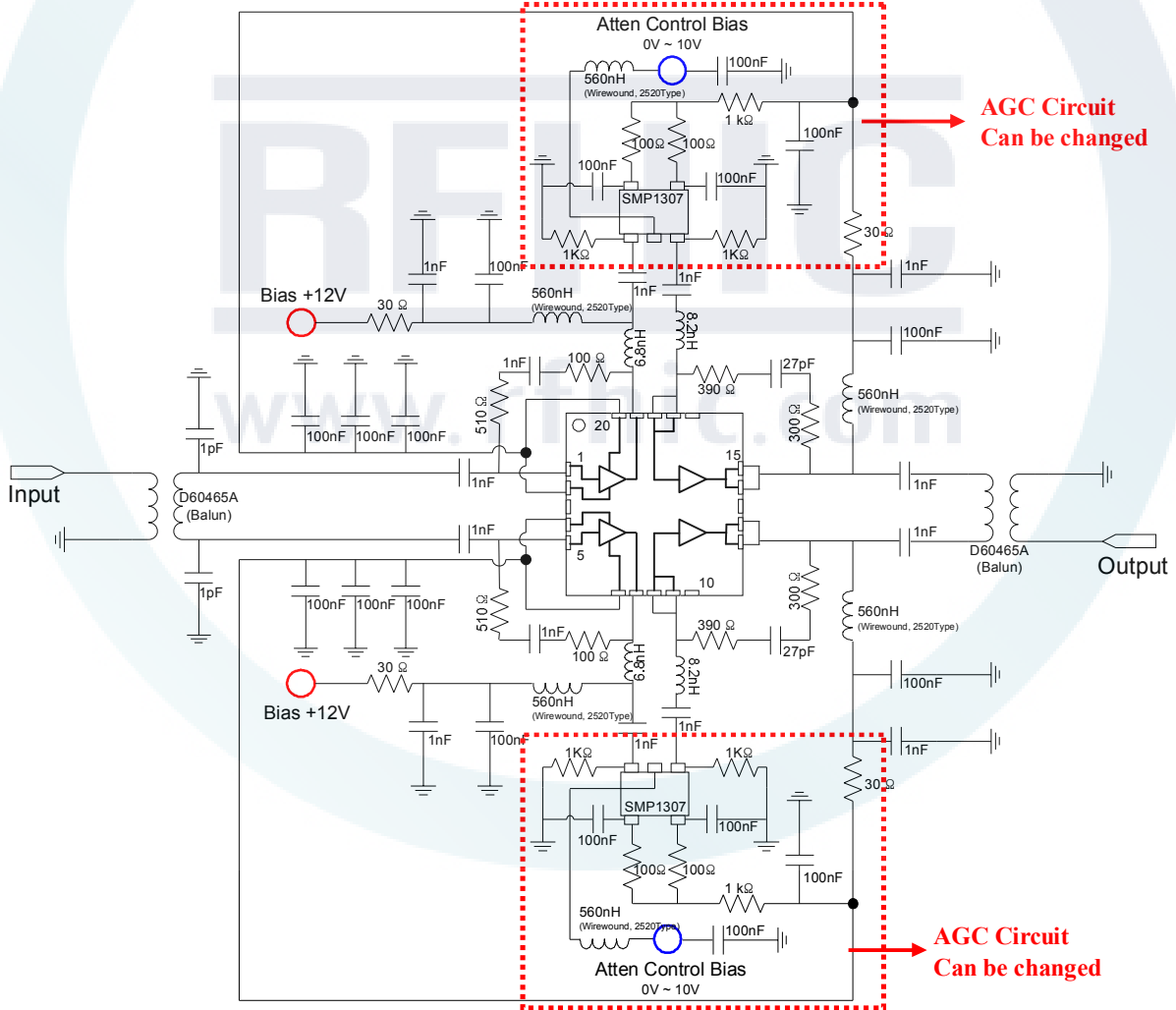

Typical Performance @ Vdd=12V, Ids=130mA, T=25°C, 75ohm System, AGC Range: Vcontrol = 0 ~ 10V

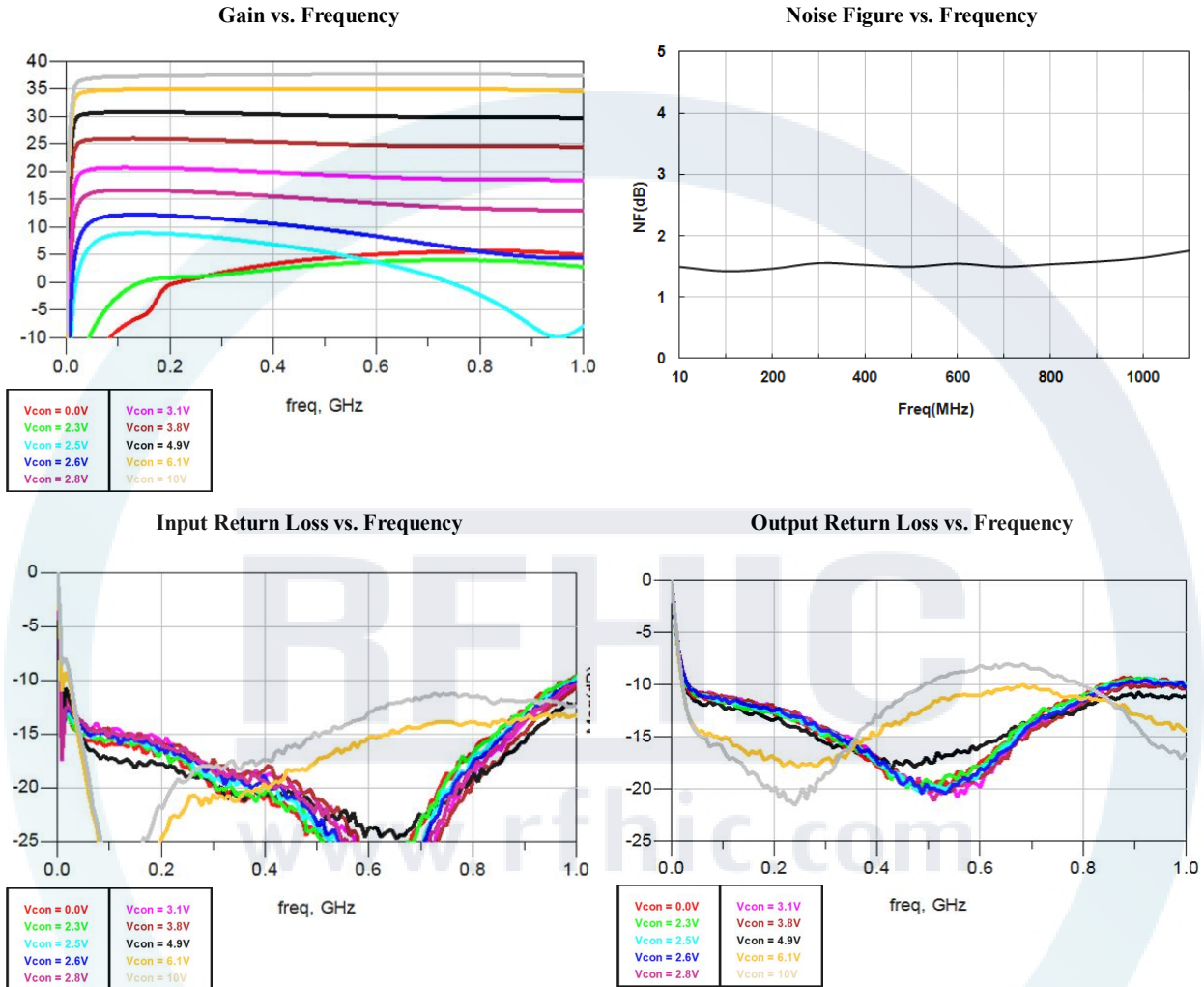

Multi-Tone Test: 135CH\_FLAT @ Output +30dBmV/ch, Vctr = 10V

FRQ	XMD(NCTA)	CTB_RAW	CTB_COR	N-FLR	CSU_RAW	CSU_COR	CSU_FRQ	CSL_RAW	CSL_COR	CSL_FRQ
55.25	60.9	66.1	67.8	71	70.4	75	109.99	63.1	63.9	107.99
77.25	61	67.4	69.6	71.3	62.3	63	77.99	70	74.3	75.89
109.25	61.9	67.6	69.5	72	70.4	74.7	110	62.7	63.2	107.99
211.25	61.2	65.8	67.5	71.1	69.9	74.3	212.5	63.9	64.8	209.99
331.25	61.5	66.6	68.5	71.1	69	73.4	332.49	64.6	65.9	329.99
445.25	61.8	66	67.5	71.7	68.4	71	446.49	64.9	66	443.98
547.25	60.5	65	66.4	70.6	64.3	65.4	548.49	65.3	67	545.98
637.25	60.3	63.7	64.7	70.6	64.7	66	638.49	65.3	66.7	635.98
745.25	58.8	64.2	65.3	70.8	64.1	65.1	746.49	67.7	70.7	743.99
859.25	59	64.3	65.9	69.4	63.1	64.2	860.49	69	73.3	857.98
Min	58.8	63.7	64.7	69.4	62.3	63	77.99	62.7	63.2	75.89
Max	61.9	67.6	69.6	72	70.4	75	860.49	70	74.3	857.98



**Package Dimension (Type: QFN4x4)**

\* Unit: mm[inch] | Tolerance ±0.2[.008]

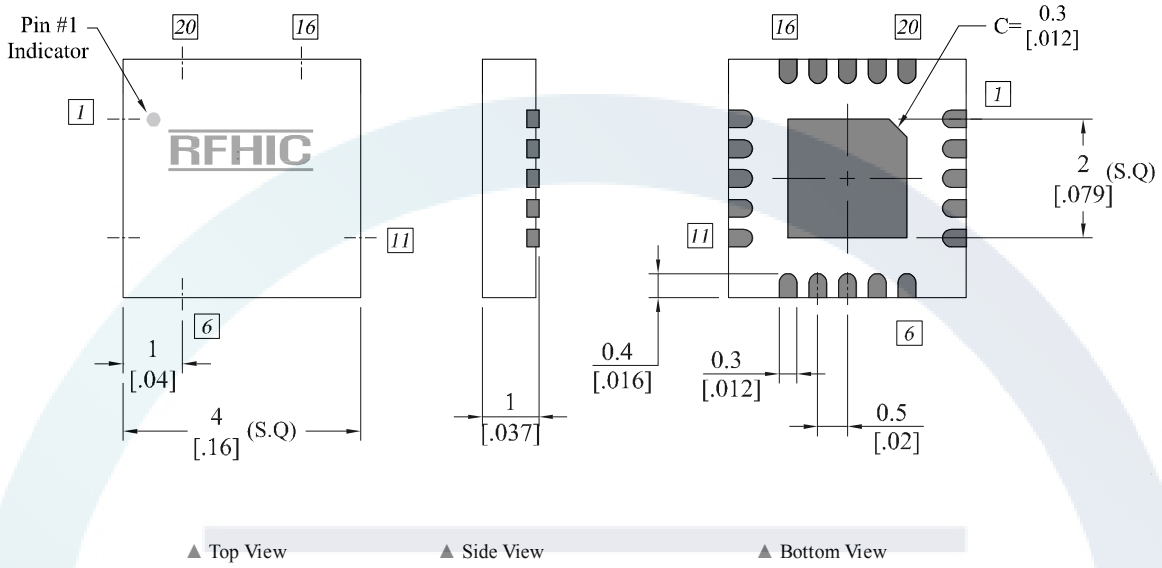

Pin Description							
Pin No	Function	Pin No	Function	Pin No	Function	Pin No	Function
1	AMP1_IN	6	AMP2_Source	11	AMP4_OUT	16	N/C
2	AMP1_Source	7	AMP2_OUT	12	AMP4_OUT	17	AMP3_IN
3	N/C	8	AMP4_IN	13	N/C	18	AMP3_IN
4	AMP2_Source	9	AMP4_IN	14	AMP3_OUT	19	AMP1_OUT
5	AMP2_IN	10	N/C	15	AMP3_OUT	20	AMP1_Source

\*N/C: Not Connected

**\* Mounting Configuration Notes**

1. Ground / thermal via holes are critical for the proper performance of this device.
2. Add as much copper as possible to inner and outer layers near the part to ensure optimal thermal performance.
3. Mounting screws can be added near the part to fasten the board to a heatsink. Ensure that the ground / thermal via hole region contacts the heatsink.
4. Do not put solder mask on the backside of the PCB in the region where the board contacts the heatsink.
5. RF trace width depends upon the PCB material and construction.
6. Use 1 oz. Copper minimum.

**Revision History**

Part Number	Release Date	Version	Modification	Data Sheet Status
ACQ629	2014.04.22	1.1	Absolute Maximum Ratings (Delete Tj Typ)	-
ACQ629	2013.12.17	1.0	Newly created & New datasheet format.	-



RFHIC Corporation reserves the right to make changes to any products herein or to discontinue any product at any time without notice. While product specifications have been thoroughly examined for reliability, RFHIC Corporation strongly recommends buyers to verify that the information they are using is accurate before ordering. RFHIC Corporation does not assume any liability for the suitability of its products for any particular purpose, and disclaims any and all liability, including without limitation consequential or incidental damages. RFHIC products are not intended for use in life support equipment or application where malfunction of the product can be expected to result in personal injury or death. Buyer uses or sells such products for any such unintended or unauthorized application, buyer shall indemnify, protect and hold RFHIC Corporation and its directors, officers, stockholders, employees, representatives and distributors harmless against any and all claims arising out of such unauthorized use.

Sales, inquiries and support should be directed to the local authorized geographic distributor for RFHIC Corporation. For customers in the US, please contact the US Sales Team at 919-677-8780. For all other inquiries, please contact the International Sales Team at 82-31-8069-3036.