

High Performance HCSL Fanout Buffer

Features

- 4 HCSL outputs
- Up to 250MHz output frequency
- Ultra low additive phase jitter: < 0.1 ps (typ)
- Two selectable inputs
- Low delay from input to output (Tpd typ. 1.5ns)
- 2.5V / 3.3V power supply
- Industrial temperature support
- TSSOP-20 package

Description

The PI6C4931504-04 is a high performance fanout buffer device which supports up to 250MHz frequency. This device is ideal for systems that need to distribute low jitter clock signals to multiple destinations.

Applications

- Networking systems including switches and Routers
- High frequency backplane based computing and telecom platforms

Block Diagram

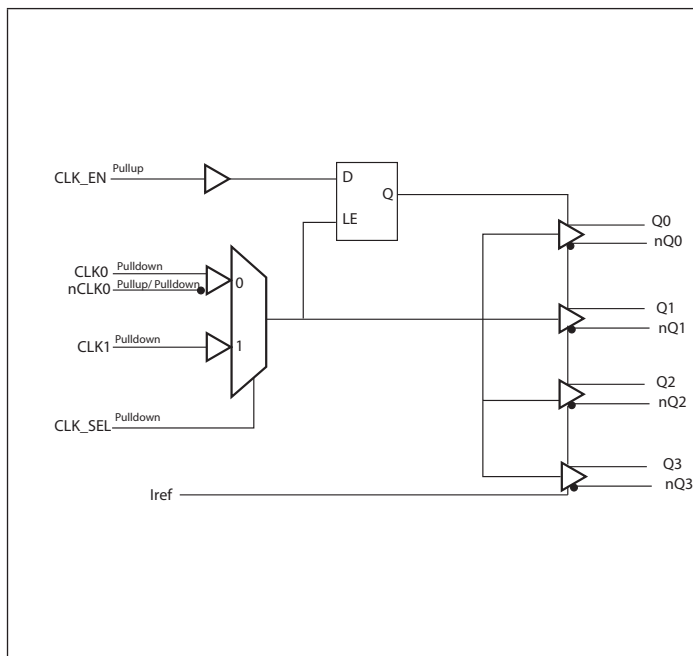

Pin Configuration (20-Pin TSSOP)

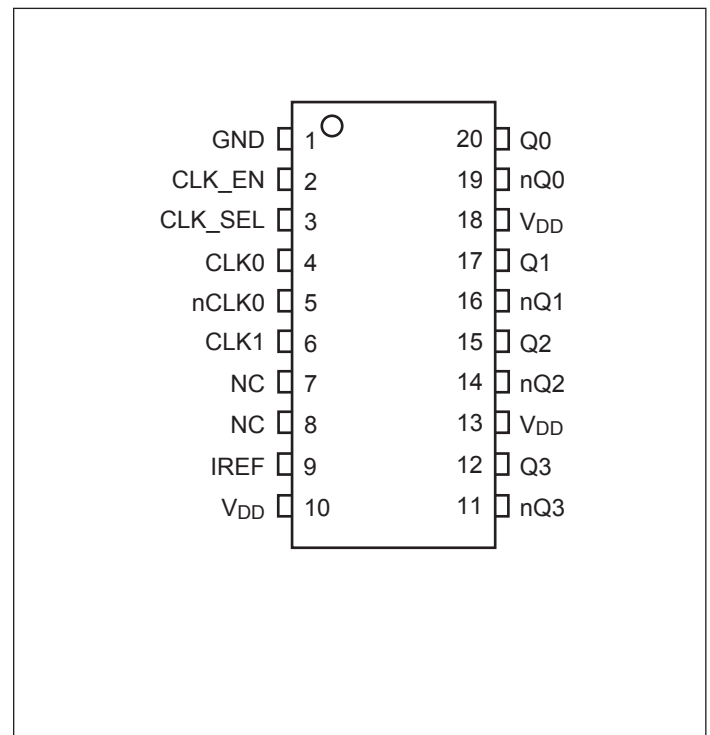

Pinout Table

Pin #	Pin Name	Type	Description
1	GND	Power	Ground
2	CLK_EN	Input	Clock output enable/ disable
3	CLK_SEL	Input	Clock input source selection pin
4, 5	CLK0 nCLK0	Input	Clock input
6	CLK1	Input	Clock input
7, 8	NC	-	No connect
9	IREF	Power	External resistor connection to set differential output current
10, 13, 18	V _{DD}	Power	Power supply
11, 12	nQ3 Q3	Output	HCSL output clock
14, 15	nQ2 Q2	Output	HCSL output clock
16, 17	nQ1 Q1	Output	HCSL output clock
19, 20	nQ0 Q0	Output	HCSL output clock

Function Table

Table 1: Input select function

CLK_SEL	Function
0	CLK0, nCLK0
1	CLK1

Table 2: Output Enable function

CLK_EN	Outputs	
	Q0:Q4	nQ0:nQ4
0	Disabled; LOW	Disabled; HIGH
1	Enabled	Enabled

Maximum Ratings (Above which the useful life may be impaired. For user guidelines, not tested)

Storage temperature.....	-55 to +150°C
Supply Voltage to Ground Potential (V_{DD}).....	-0.5 to +4.6V
Inputs (Referenced to GND)	-0.5 to $V_{DD}+0.5V$
Clock Output (Referenced to GND).....	-0.5 to $V_{DD}+0.5V$
Soldering Temperature (Max of 10 seconds)	+260°C

Note:

Stresses greater than those listed under MAXIMUM RATINGS may cause permanent damage to the device. This is a stress rating only and functional operation of the device at these or any other conditions above those indicated in the operational sections of this specification is not implied. Exposure to absolute maximum rating conditions for extended periods may affect reliability.

Power Supply Characteristics and Operating Conditions

Symbol	Parameter	Test Condition	Min.	Typ.	Max.	Units
V_{DD}	Core Supply Voltage		2.97		3.63	V
			2.375		2.625	V
I_{DD}	Power Supply Current	$V_{DD} = 3.3V$, Unloaded			70	mA
		$V_{DD} = 2.5V$, Unloaded			70	
T_A	Ambient Operating Temperature		-40		85	°C

DC Electrical Specifications - Differential Inputs

Symbol	Parameter		Min.	Typ.	Max.	Units
I_{IH}	Input High current: CLK0, nCLK0	Input = V_{DD}			200	uA
I_{IL}	Input Low current: nCLK0		-200			uA
	Input Low current: CLK0		-10			uA
C_{IN}	Input capacitance			4		PF
V_{IH}	Input high voltage				$V_{DD}+0.3$	V
V_{IL}	Input low voltage		-0.3			V
V_{ID}	Input Differential Amplitude PK-PK		150		1300	mV
V_{CM}	Common mode input voltage		GND + 0.5		$V_{DD}-0.85$	V

DC Electrical Specifications - LVCMOS Inputs

Symbol	Parameter		Conditions	Min.	Typ.	Max.	Units
I _{IH}	Input High current	CLK1, CLK_SEL	Input = V _{DD}			200	uA
		CLK_EN				20	uA
I _{IL}	Input Low current	CLK1, CLK_SEL	Input = GND	-10			uA
		CLK_EN		-200			uA
V _{IH}	Input high voltage		V _{DD} =3.3V	2.0		3.765	V
V _{IL}	Input low voltage		V _{DD} =3.3V	-0.3		0.8	V
V _{IH}	Input high voltage		V _{DD} =2.5V	1.7		2.8	V
V _{IL}	Input low voltage		V _{DD} =2.5V	-0.3		0.7	V

DC Electrical Specifications – HCSL Outputs

Parameter	Description	Conditions	Min.	Typ.	Max.	Units
V _{OH}	Output High voltage	V _{DD} =3.3V	520	800		mV
V _{OL}	Output Low voltage	V _{DD} =3.3V		0	150	mV

AC Electrical Specifications – Differential Outputs

Parameter	Description	Conditions	Min.	Typ.	Max.	Units
f_{OUT}	Output frequency				250	MHz
T_r	Output rise time	From 20% to 80%	175		700	ps
T_f	Output fall time	From 80% to 20%	175		700	ps
T_{ODC}	Output duty cycle		48		52	%
T_j	Buffer additive jitter RMS			0.1		ps
V_{MAX}	Absolute Maximum Output Voltage				1150	mV
V_{MIN}	Absolute Minimum Output Voltage		-300			mV
V_{CROSS}	Absolute crossing voltage	HCSL	250		550	mV
DV_{CROSS}	Total variation of crossing voltage	HCSL			140	mV
T_{SK}	Output Skew			40	100	ps
T_{PD}	Propagation Delay			1500		ps
$T_{P2P\ Skew}$	Part to Part Skew ¹				600	ps

Notes:

1. This parameter is guaranteed by design

Configuration test load board termination for HCSL Outputs

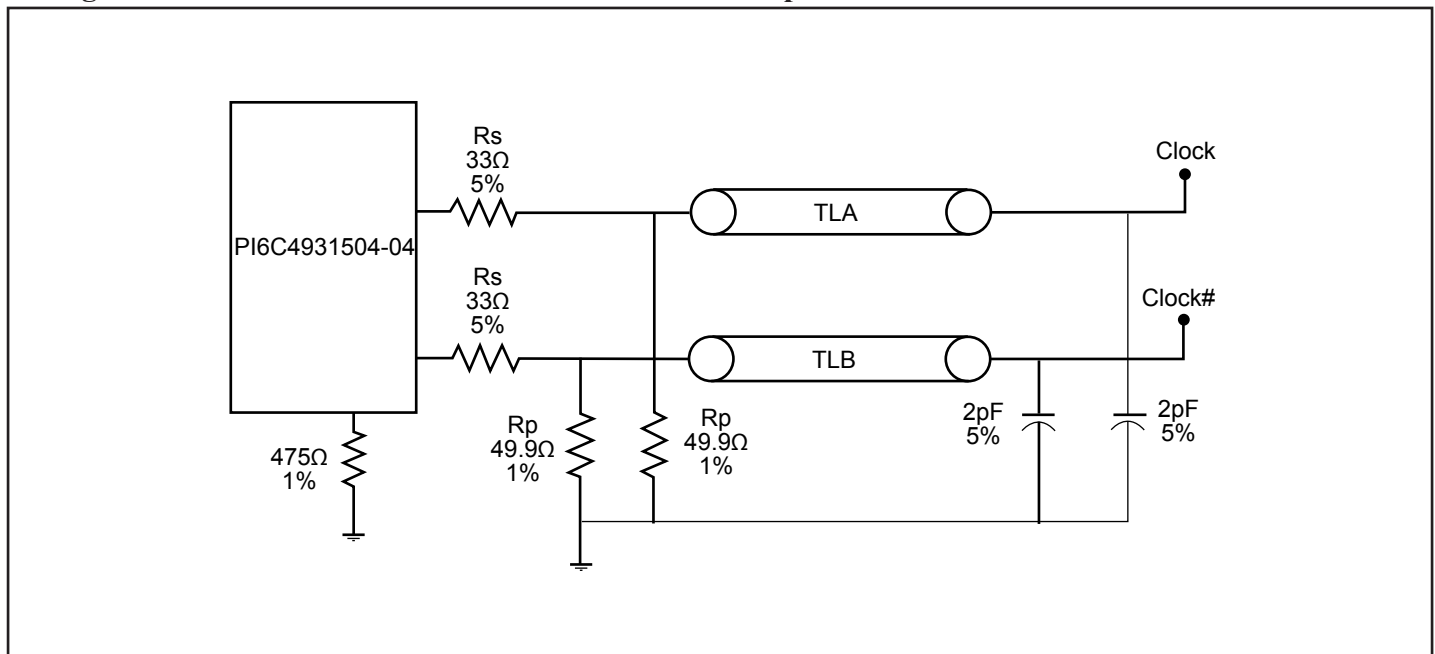

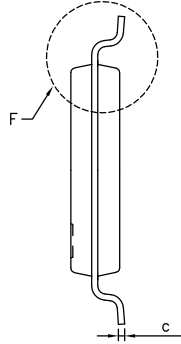
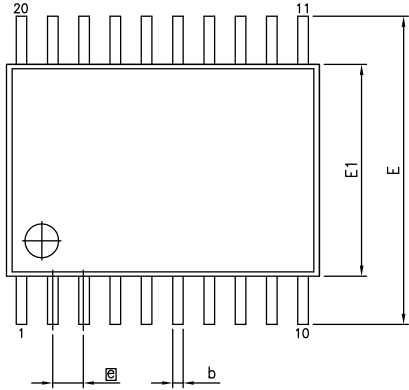

VARIATIONS (ALL DIMENSIONS SHOWN IN MM)

SYMBOLS	MIN.	NOM.	MAX.
A	—	—	1.20
A1	0.05	—	0.15
A2	0.80	—	1.05
b	0.19	—	0.30
C	0.09	—	0.20
D	6.40	6.50	6.60
E1	4.30	4.40	4.50
E	6.40 BSC		
e	0.65 BSC		
L1	1.00 REF		
L	0.45	0.60	0.75
S	0.20	—	—
θ	0°	—	8°

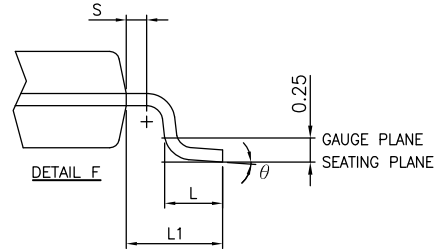
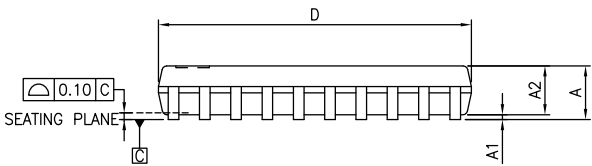

- Notes:**
1. Refer JEDEC MO-153F/AC
 2. Controlling dimensions in millimeters
 3. Package outline exclusive of mold flash and metal burr

PERICOM Enabling Serial Connectivity	DATE: 05/03/12
DESCRIPTION: 20-pin, 173mil Wide TSSOP	
PACKAGE CODE: L	
DOCUMENT CONTROL #: PD-1311	REVISION: F

Note:

- For latest package info, please check: <http://www.pericom.com/products/packaging/mechanicals.php>

Ordering Information⁽¹⁻³⁾

Ordering Code	Package Code	Package Description
PI6C4931504-04LIE	L	20-pin, Pb-free & Green, TSSOP, (L20)

- Notes:**
1. Thermal characteristics can be found on the company web site at www.pericom.com/packaging/
 2. E = Pb-free and Green
 3. Adding an X suffix = Tape/Reel