

Features

- Very high speed: 45 ns
- Wide voltage range: 2.20 V to 3.60 V
- Ultra low standby power
 - Typical standby current: 1.5 μ A
 - Maximum standby current: 12 μ A
- Ultra low active power
 - Typical active current: 2.2 mA at f = 1 MHz
- Easy memory expansion with \overline{CE}_1 , CE_2 and \overline{OE} features
- Automatic power-down when deselected
- CMOS for optimum speed/power
- Offered in Pb-free 48-ball FBGA package. For Pb-free 48-pin TSOP I package, refer to [CY62167EV30](#) data sheet.

Functional Description

The CY62168EV30 is a high performance CMOS static RAM organized as 2 M words by 8-bits. This device features advanced circuit design to provide an ultra low active current. This is ideal for providing More Battery Life™ (MoBL®) in portable applications such as cellular telephones. The device also has an

automatic power-down feature that significantly reduces power consumption by 90% when addresses are not toggling. Placing the device into standby mode reduces power consumption by more than 99% when deselected (Chip Enable 1 (\overline{CE}_1) HIGH or Chip Enable 2 (CE_2) LOW). The input and output pins (I/O_0 through I/O_7) are placed in a high impedance state when: the device is deselected (Chip Enable 1 (\overline{CE}_1) HIGH or Chip Enable 2 (CE_2) LOW), outputs are disabled (\overline{OE} HIGH), or a write operation is in progress (Chip Enable 1 (\overline{CE}_1) LOW and Chip Enable 2 (CE_2) HIGH and \overline{WE} LOW).

Write to the device by taking Chip Enable 1 (\overline{CE}_1) LOW and Chip Enable 2 (CE_2) HIGH and the Write Enable (\overline{WE}) input LOW. Data on the eight I/O pins (I/O_0 through I/O_7) is then written into the location specified on the address pins (A_0 through A_{20}).

Read from the device by taking Chip Enable 1 (\overline{CE}_1) and Output Enable (\overline{OE}) LOW and Chip Enable 2 (CE_2) HIGH while forcing Write Enable (\overline{WE}) HIGH. Under these conditions, the contents of the memory location specified by the address pins will appear on the I/O pins.

The eight input and output pins (I/O_0 through I/O_7) are placed in a high impedance state when the device is deselected (\overline{CE}_1 HIGH or CE_2 LOW), the outputs are disabled (\overline{OE} HIGH), or a write operation is in progress (\overline{CE}_1 LOW and CE_2 HIGH and \overline{WE} LOW). See the [Truth Table on page 11](#) for a complete description of read and write modes.

Logic Block Diagram

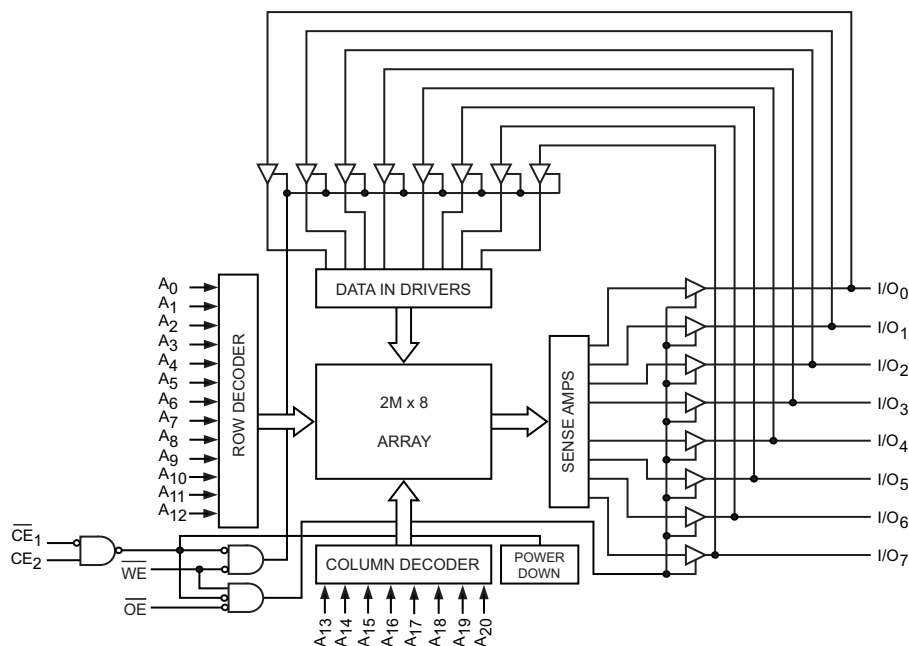

Contents

Pin Configuration	3	Ordering Information	12
Product Portfolio	3	Ordering Code Definitions	12
Maximum Ratings	4	Package Diagram	13
Operating Range	4	Acronyms	14
DC Electrical Characteristics	4	Document Conventions	14
Capacitance	5	Units of Measure	14
Thermal Resistance	5	Document History Page	15
AC Test Loads and Waveforms	5	Sales, Solutions, and Legal Information	16
Data Retention Characteristics	6	Worldwide Sales and Design Support	16
Data Retention Waveform	6	Products	16
Switching Characteristics	7	PSoC® Solutions	16
Switching Waveforms	8	Cypress Developer Community	16
Truth Table	11	Technical Support	16

Pin Configuration

Figure 1. 48-ball FBGA pinout (Top View) [1]

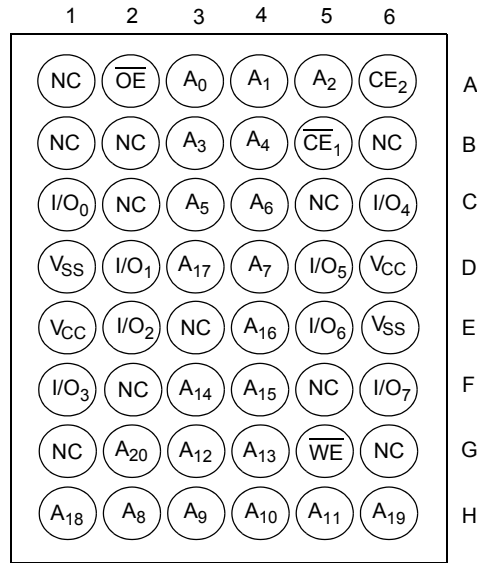

Product Portfolio

Product	V _{CC} Range (V)			Speed (ns)	Power Dissipation					
					Operating I _{CC} (mA)				Standby I _{SB2} (μA)	
	f = 1 MHz		f = f _{max}							
	Min	Typ ^[2]	Max		Typ ^[2]	Max	Typ ^[2]	Max	Typ ^[2]	Max
CY62168EV30LL	2.2	3.0	3.6	45	2.2	4.0	25	30	1.5	12

Notes

1. NC pins are not connected on the die.
2. Typical values are included for reference only and are not guaranteed or tested. Typical values are measured at V_{CC} = V_{CC(typ)}, T_A = 25 °C.

Maximum Ratings

Exceeding maximum ratings may shorten the useful life of the device. User guidelines are not tested.

Storage temperature	-65 °C to +150 °C
Ambient temperature with power applied	-55 °C to +125 °C
Supply voltage to ground potential	-0.3 V to $V_{CC(max)} + 0.3$ V
DC voltage applied to outputs in high Z state ^[3, 4]	-0.3 V to $V_{CC(max)} + 0.3$ V

DC input voltage ^[3, 4]	-0.3 V to $V_{CC(max)} + 0.3$ V
Output current into outputs (LOW)	20 mA
Static discharge voltage (MIL-STD-883, method 3015)	> 2001 V
Latch-up current	> 200 mA

Operating Range

Range	Ambient Temperature (T_A) ^[5]	V_{CC} ^[6]
Industrial	-40 °C to +85 °C	2.2 V to 3.6 V

DC Electrical Characteristics

Over the operating range

Parameter	Description	Test Conditions	CY62168EV30-45			Unit	
			Min	Typ ^[7]	Max		
V_{OH}	Output HIGH voltage	$2.2 \leq V_{CC} \leq 2.7$	$I_{OH} = -0.1$ mA	2.0	-	-	V
		$2.7 \leq V_{CC} \leq 3.6$	$I_{OH} = -1.0$ mA	2.4	-	-	
V_{OL}	Output LOW voltage	$2.2 \leq V_{CC} \leq 2.7$	$I_{OL} = 0.1$ mA	-	-	0.4	V
		$2.7 \leq V_{CC} \leq 3.6$	$I_{OH} = 2.1$ mA	-	-	0.4	
V_{IH}	Input HIGH voltage	$2.2 \leq V_{CC} \leq 2.7$		1.8	-	$V_{CC} + 0.3$	V
		$2.7 \leq V_{CC} \leq 3.6$		2.2	-	$V_{CC} + 0.3$	
V_{IL}	Input LOW voltage	$2.2 \leq V_{CC} \leq 2.7$		-0.3	-	0.6	V
		$2.7 \leq V_{CC} \leq 3.6$		-0.3	-	0.8	
I_{IX}	Input leakage current	$GND \leq V_I \leq V_{CC}$		-1	-	+1	μ A
I_{OZ}	Output leakage current	$GND \leq V_O \leq V_{CC}$, Output disabled		-1	-	+1	μ A
I_{CC}	V_{CC} operating supply current	$f = f_{MAX} = 1/t_{RC}$	$V_{CC} = 3.6$ V, $I_{OUT} = 0$ mA, CMOS level	-	25	30	mA
		$f = 1$ MHz		-	2.2	4.0	
I_{SB1} ^[8]	Automatic CE power-down current – CMOS inputs	$\overline{CE}_1 \geq V_{CC} - 0.2$ V or $CE_2 \leq 0.2$ V, $V_{IN} \geq V_{CC} - 0.2$ V, $V_{IN} \leq 0.2$ V, $f = f_{MAX}$ (address and data only), $f = 0$ (OE, \overline{WE})		-	1.5	12	μ A
I_{SB2} ^[8]	Automatic CE power-down current – CMOS inputs	$\overline{CE}_1 \geq V_{CC} - 0.2$ V or $CE_2 \leq 0.2$ V, $V_{IN} \geq V_{CC} - 0.2$ V or $V_{IN} \leq 0.2$ V, $f = 0$, $V_{CC} = 3.6$ V		-	1.5	12	μ A

Notes

- $V_{IL(min)}$ = -2.0 V for pulse durations less than 20 ns.
- $V_{IH(max)}$ = $V_{CC} + 0.75$ V for pulse durations less than 20 ns.
- T_A is the "Instant-On" case temperature.
- Full device AC operation assumes a 100 μ s ramp time from 0 to $V_{CC(min)}$ and 200 μ s wait time after V_{CC} stabilization.
- Typical values are included for reference only and are not guaranteed or tested. Typical values are measured at $V_{CC} = V_{CC(typ)}$, $T_A = 25$ °C.
- Chip enables (\overline{CE}_1 and CE_2) must be at CMOS level to meet the $I_{SB1} / I_{SB2} / I_{CCDR}$ spec. Other inputs can be left floating.

Capacitance

Parameter ^[9]	Description	Test Conditions	Max	Unit
C _{IN}	Input capacitance	T _A = 25 °C, f = 1 MHz, V _{CC} = V _{CC(typ)}	8	pF
C _{OUT}	Output capacitance		10	pF

Thermal Resistance

Parameter ^[9]	Description	Test Conditions	48-ball FBGA	Unit
Θ _{JA}	Thermal resistance (junction to ambient)	Still air, soldered on a 3 × 4.5 inch, two-layer printed circuit board	55	°C/W
Θ _{JC}	Thermal resistance (junction to case)		16	°C/W

AC Test Loads and Waveforms

Figure 2. AC Test Loads and Waveforms

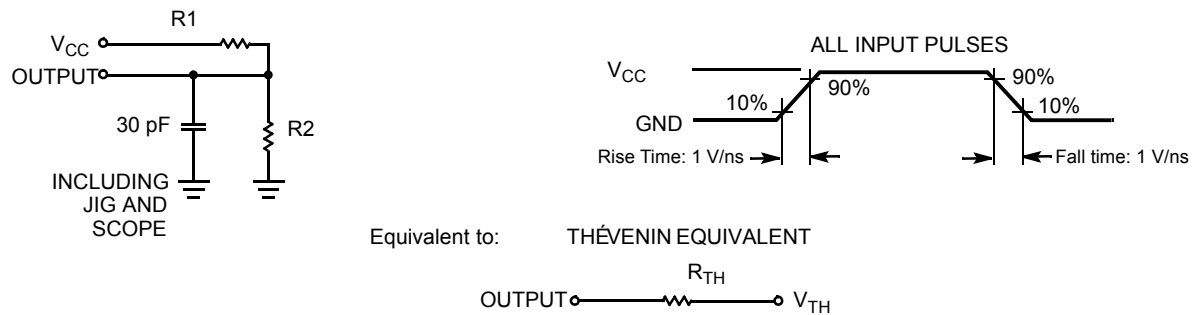

Parameters	2.5 V (2.2 V to 2.7 V)	3.0 V (2.7 V to 3.6 V)	Unit
R ₁	16600	1103	Ω
R ₂	15400	1554	Ω
R _{TH}	8000	645	Ω
V _{TH}	1.2	1.75	V

Note

9. Tested initially and after any design or process changes that may affect these parameters.

Data Retention Characteristics

Over the Operating Range

Parameter	Description	Conditions	Min	Typ ^[10]	Max	Unit
V _{DR}	V _{CC} for data retention		1.5	–	3.6	V
I _{CCDR} ^[11]	Data retention current	V _{CC} = 1.5 V CE ₁ ≥ V _{CC} – 0.2 V or CE ₂ ≤ 0.2 V V _{IN} ≥ V _{CC} – 0.2 V or V _{IN} ≤ 0.2 V	–	–	10	μA
t _{CDR} ^[12]	Chip deselect to data retention time		0	–	–	ns
t _R ^[13]	Operation recovery time		45	–	–	ns

Data Retention Waveform

Figure 3. Data Retention Waveform

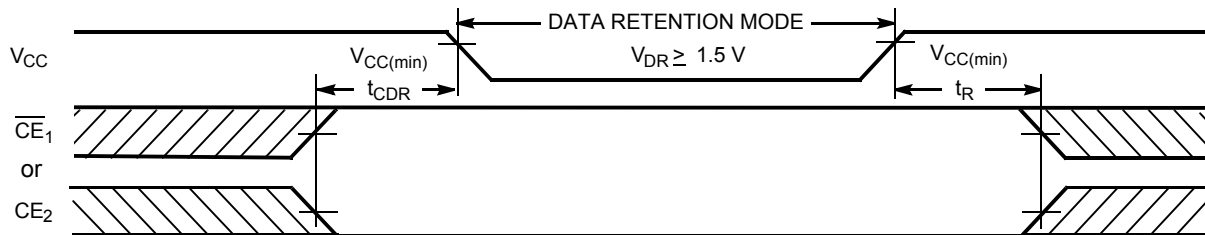

Notes

- 10. Typical values are included for reference only and are not guaranteed or tested. Typical values are measured at V_{CC} = V_{CC}(typ), T_A = 25 °C.
- 11. Chip enables (CE₁ and CE₂) must be at CMOS level to meet the I_{SB1} / I_{SB2} / I_{CCDR} spec. Other inputs can be left floating.
- 12. Tested initially and after any design or process changes that may affect these parameters.
- 13. Full Device AC operation requires linear V_{CC} ramp from V_{DR} to V_{CC}(min) ≥ 100 μs or stable at V_{CC}(min) ≥ 100 μs.

Switching Characteristics

Over the Operating Range

Parameter ^[14, 15]	Description	45 ns		Unit
		Min	Max	
Read Cycle				
t_{RC}	Read cycle time	45	–	ns
t_{AA}	Address to data valid	–	45	ns
t_{OHA}	Data hold from address change	10	–	ns
t_{ACE}	\overline{CE}_1 LOW and CE_2 HIGH to data valid	–	45	ns
t_{DOE}	\overline{OE} LOW to data valid	–	22	ns
t_{LZOE}	\overline{OE} LOW to low $Z^{[16]}$	5	–	ns
t_{HZOE}	\overline{OE} HIGH to high $Z^{[16, 17]}$	–	18	ns
t_{LZCE}	\overline{CE}_1 LOW and CE_2 HIGH to low $Z^{[16]}$	10	–	ns
t_{HZCE}	\overline{CE}_1 HIGH or CE_2 LOW to high $Z^{[16, 17]}$	–	18	ns
t_{PU}	\overline{CE}_1 LOW and CE_2 HIGH to power-up	0	–	ns
t_{PD}	\overline{CE}_1 HIGH or CE_2 LOW to power-down	–	45	ns
Write Cycle^[18]				
t_{WC}	Write cycle time	45	–	ns
t_{SCE}	\overline{CE}_1 LOW and CE_2 HIGH to write end	35	–	ns
t_{AW}	Address setup to write end	35	–	ns
t_{HA}	Address hold from write end	0	–	ns
t_{SA}	Address setup to write start	0	–	ns
t_{PWE}	\overline{WE} pulse width	35	–	ns
t_{SD}	Data setup to write end	25	–	ns
t_{HD}	Data hold from write end	0	–	ns
t_{HZWE}	\overline{WE} LOW to high $Z^{[16, 17]}$	–	18	ns
t_{LZWE}	\overline{WE} HIGH to low $Z^{[16]}$	10	–	ns

Notes

14. In an earlier revision of this device, under a specific application condition, READ and WRITE operations were limited to switching of the chip enable signal as described in the Application Note AN66311. However, the issue has been fixed and in production now, and hence, this Application Note is no longer applicable. It is available for download on our website as it contains information on the date code of the parts, beyond which the fix has been in production.
15. Test conditions for all parameters other than tri-state parameters assume signal transition time of 3 ns or less (1 V/ns), timing reference levels of $V_{CC(typ)}/2$, input pulse levels of 0 to $V_{CC(typ)}$, and output loading of the specified I_{OL}/I_{OH} as shown in Figure 2 on page 5.
16. At any given temperature and voltage condition, t_{HZCE} is less than t_{LZCE} , t_{HZOE} is less than t_{LZOE} , and t_{HZWE} is less than t_{LZWE} for any given device.
17. t_{HZOE} , t_{HZCE} , and t_{HZWE} transitions are measured when the outputs enter a high impedance state.
18. The internal write time of the memory is defined by the overlap of \overline{WE} , $CE_1 = V_{IL}$, and $CE_2 = V_{IH}$. All signals must be ACTIVE to initiate a write and any of these signals can terminate a write by going INACTIVE. The data input setup and hold timing should be referenced to the edge of the signal that terminates the write.

Switching Waveforms

Figure 4. Read Cycle No. 1 (Address Transition Controlled) [19, 20]

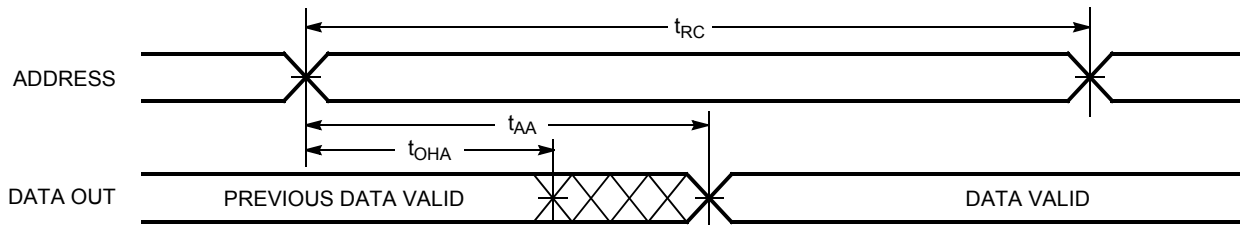
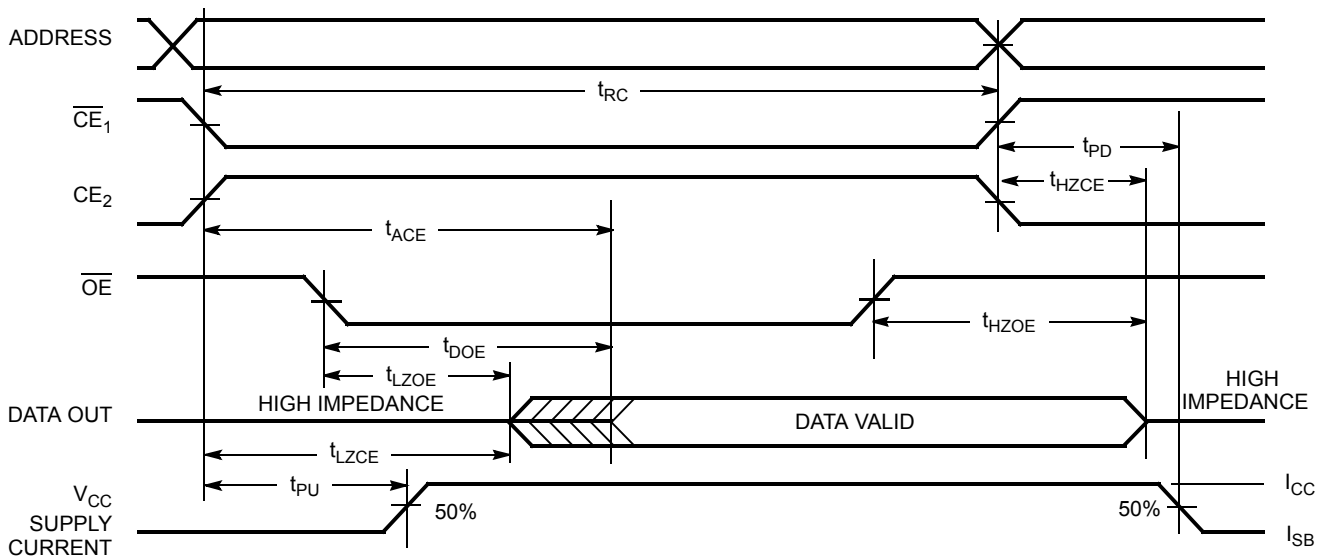

Figure 5. Read Cycle No. 2 (\overline{OE} Controlled) [20, 21]



Notes

- 19. The device is continuously selected. \overline{OE} , $\overline{CE}_1 = V_{IL}$, and $CE_2 = V_{IH}$.
- 20. WE is HIGH for read cycle.
- 21. Address valid before or similar to \overline{CE}_1 transition LOW and CE_2 transition HIGH.

Switching Waveforms (continued)

Figure 6. Write Cycle No. 1 (\overline{WE} Controlled) [22, 23, 24]

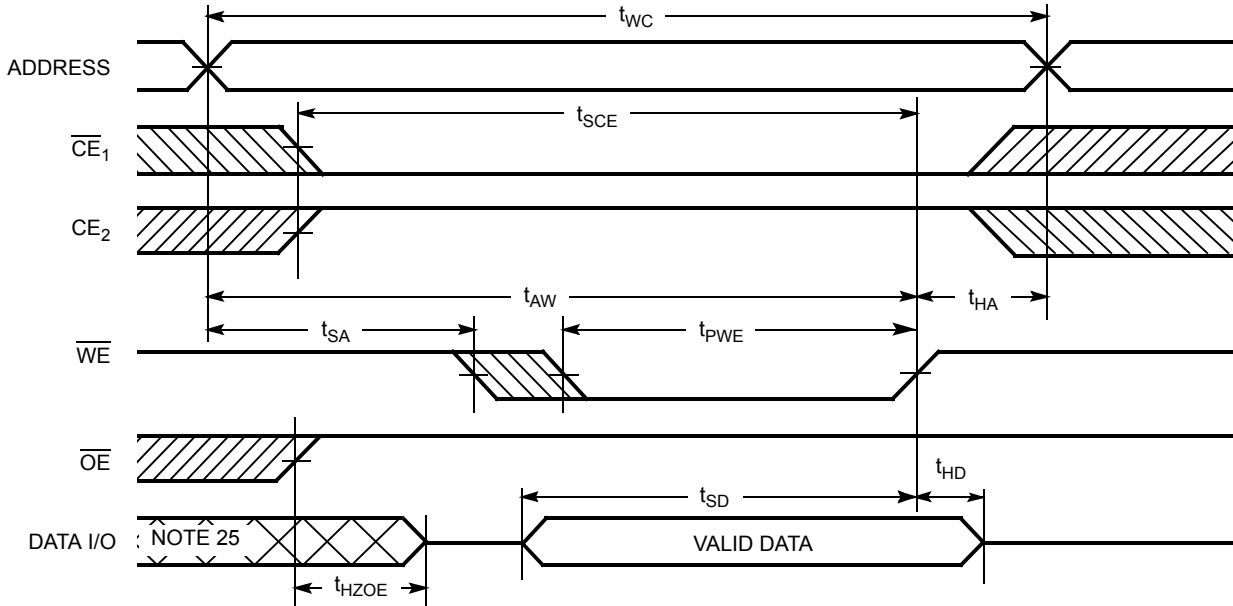
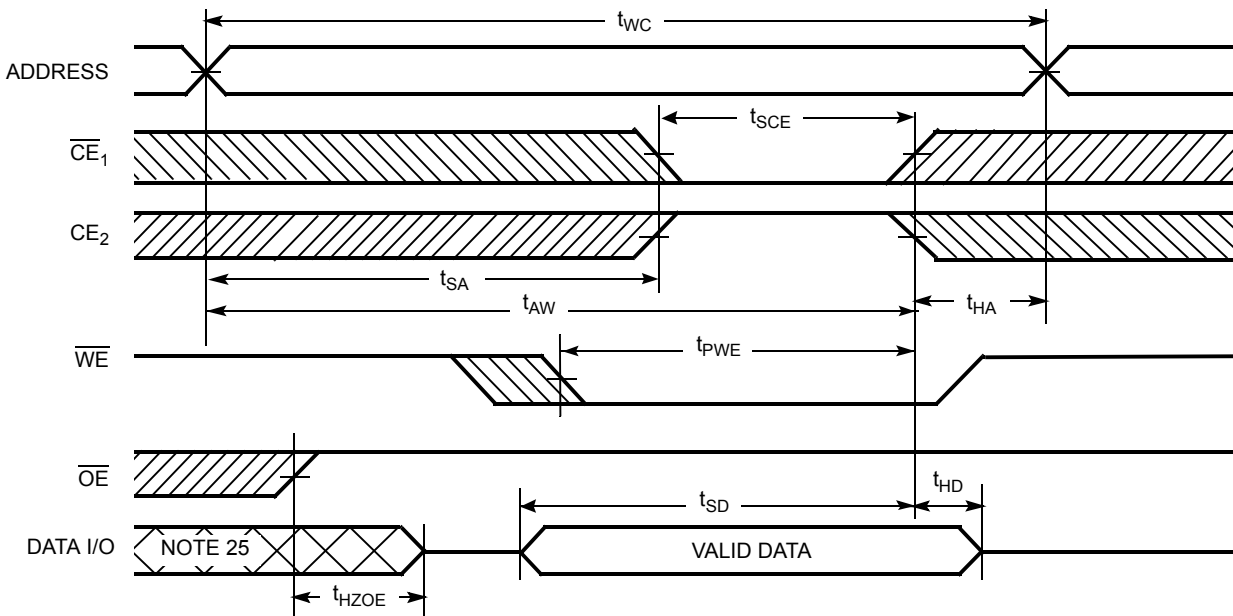

Figure 7. Write Cycle No. 2 (\overline{CE}_1 or CE_2 Controlled) [22, 23, 24]



Notes

- 22. The internal write time of the memory is defined by the overlap of \overline{WE} , $\overline{CE}_1 = V_{IL}$, and $CE_2 = V_{IH}$. All signals must be ACTIVE to initiate a write and any of these signals can terminate a write by going INACTIVE. The data input setup and hold timing should be referenced to the edge of the signal that terminates the write.
- 23. Data I/O is high impedance if $OE = V_{IH}$.
- 24. If \overline{CE}_1 goes HIGH and CE_2 goes LOW simultaneously with $\overline{WE} = V_{IH}$, the output remains in a high impedance state.
- 25. During this period the I/Os are in output state. Do not apply input signals.

Switching Waveforms (continued)

Figure 8. Write Cycle No. 3 (\overline{WE} Controlled, \overline{OE} LOW) [26]

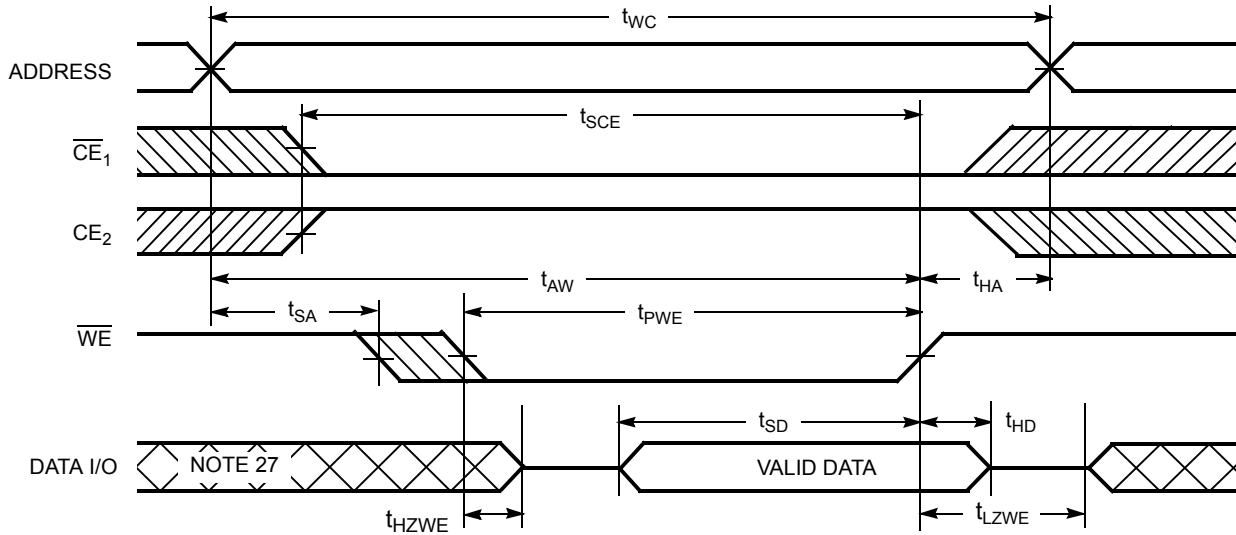

Notes

- 26. If \overline{CE}_1 goes HIGH and CE_2 goes LOW simultaneously with $\overline{WE} = V_{IH}$, the output remains in a high impedance state.
- 27. During this period the I/Os are in output state. Do not apply input signals.

Truth Table

\overline{CE}_1	CE_2	\overline{WE}	\overline{OE}	I/O	Mode	Power
H	X ^[28]	X	X	High Z	Deselect/power-down	Standby (I_{SB})
X ^[28]	L	X	X	High Z	Deselect/power-down	Standby (I_{SB})
L	H	H	L	Data out (I/O_0 – I/O_7)	Read	Active (I_{CC})
L	H	H	H	High Z	Output disabled	Active (I_{CC})
L	H	L	X	Data in (I/O_0 – I/O_7)	Write	Active (I_{CC})

Note

28. The 'X' (Do not care) state for the chip enables in the truth table refers to the logic state (either HIGH or LOW). Intermediate voltage levels on these pins is not permitted.

Ordering Information

The below table lists the CY62168EV30 MoBL key package features and ordering codes. The table contains only the parts that are currently available. If you do not see what you are looking for, contact your local sales representative. For more information, visit the Cypress website at www.cypress.com and refer to the product summary page at <http://www.cypress.com/products>.

Speed (ns)	Ordering Code	Package Diagram	Package Type	Operating Range
45	CY62168EV30LL-45BVXI	51-85150	48-ball VFBGA (Pb-free)	Industrial

Ordering Code Definitions

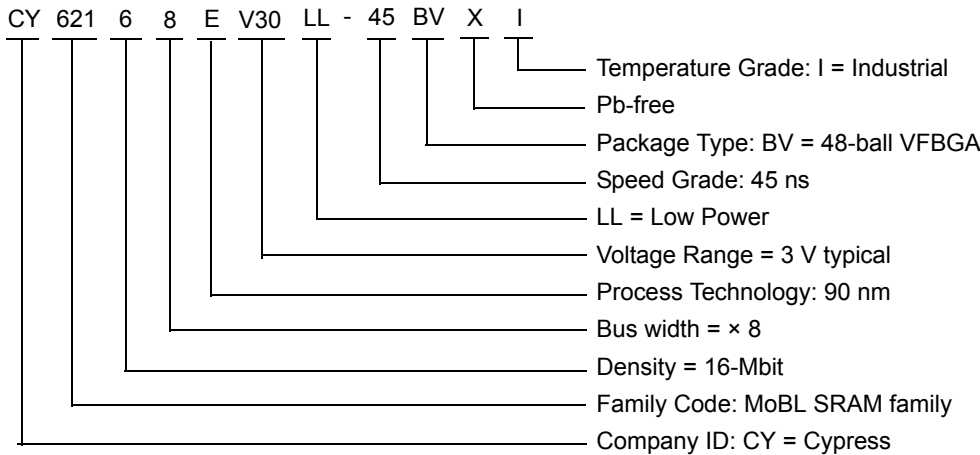

Package Diagram

Figure 9. 48-ball VFBGA (6 × 8 × 1 mm) BV48/BZ48 Package Outline, 51-85150

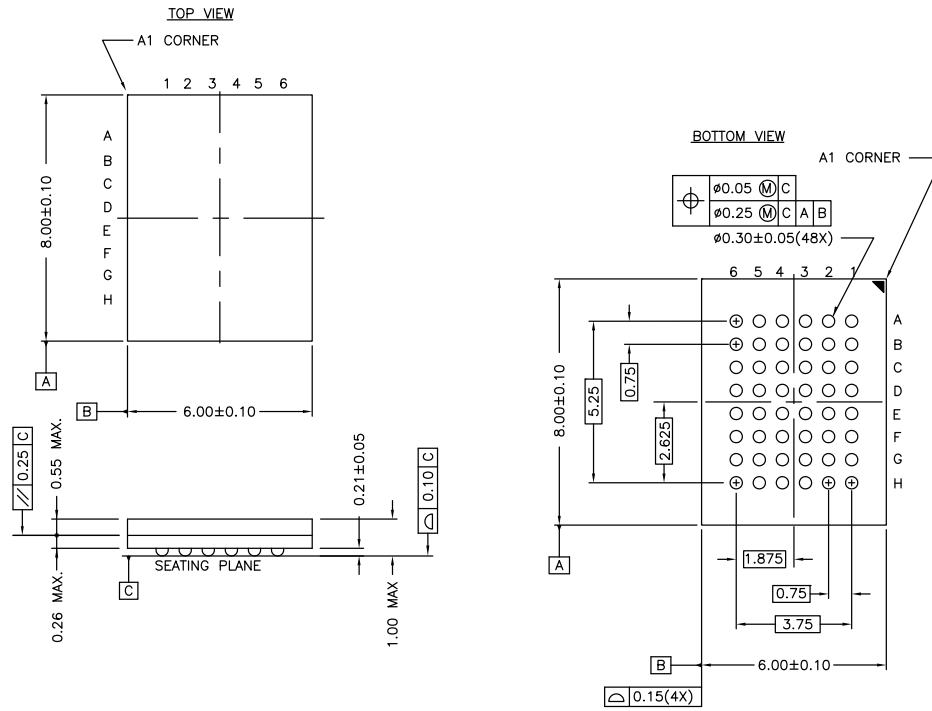

NOTE:
 PACKAGE WEIGHT: See Cypress Package Material Declaration Datasheet (PMDD) posted on the Cypress web.

51-85150 *H

Acronyms

Acronym	Description
\overline{CE}	Chip Enable
CMOS	Complementary Metal Oxide Semiconductor
FBGA	Fine-Pitch Ball Grid Array
I/O	Input/Output
\overline{OE}	Output Enable
SRAM	Static Random Access Memory
TSOP	Thin Small Outline Package
VFBGA	Very Fine-Pitch Ball Grid Array
\overline{WE}	Write Enable

Document Conventions

Units of Measure

Symbol	Unit of Measure
°C	degree Celsius
MHz	megahertz
μA	microampere
μs	microsecond
mA	milliampere
mm	millimeter
ns	nanosecond
Ω	ohm
%	percent
pF	picofarad
V	volt
W	watt

Document History Page

Document Title: CY62168EV30 MoBL®, 16-Mbit (2 M × 8) Static RAM Document Number: 001-07721				
Rev.	ECN No.	Orig. of Change	Issue Date	Description of Change
**	457686	NXR	See ECN	New data sheet.
*A	464509	NXR	See ECN	Removed TSOP I package; Added reference to CY62167EV30 TSOP I package which can be used as a 2 M × 8 SRAM Changed the I _{SB2(Typ)} value from 1.3 μA to 1.5 μA Changed the I _{CC(Typ)} value from 2 mA to 2.2 mA for f=1 MHz Test condition Changed the I _{CC(Typ)} value from 15 mA to 22 mA and I _{CC(Max)} value from 40 mA to 25 mA for f = 1 MHz Test condition Changed the I _{CCDR(Max)} value from 8.5 μA to 8 μA
*B	1138883	VKN	See ECN	Converted from preliminary to final Changed I _{CC(max)} spec from 2.8 mA to 4.0 mA for f=1 MHz Changed I _{CC(typ)} spec from 22 mA to 25 mA for f=f _{max} Changed I _{CC(max)} spec from 25 mA to 30 mA for f=f _{max} Added footnote# 8 related to I _{SB2} and I _{CCDR} Changed I _{SB1} and I _{SB2} spec from 8.5 μA to 12 μA Changed I _{CCDR} spec from 8 μA to 10 μA
*C	2934385	VKN	06/03/10	Corrected typo in Functional Description section Corrected V _{CC} stabilization time to 200 μsec Updated template. Added footnote #28 related to chip enable Updated package diagram
*D	3279426	RAME	06/10/2011	Removed the Note “For best practice recommendations, refer to the Cypress application note AN1064, SRAM System Guidelines.” in page 1 and its reference in Functional Description . Updated Package Diagram . Updated in new template.
*E	4100078	VINI	08/20/2013	Updated Switching Characteristics : Added Note 14 and referred the same note in “Parameter” column. Updated Package Diagram : spec 51-85150 – Changed revision from *F to *H. Updated in new template.
*F	4126351	NILE	09/17/2013	Updated Maximum Ratings : Updated Note 3.

Sales, Solutions, and Legal Information

Worldwide Sales and Design Support

Cypress maintains a worldwide network of offices, solution centers, manufacturer's representatives, and distributors. To find the office closest to you, visit us at [Cypress Locations](#).

Products

Automotive	cypress.com/go/automotive
Clocks & Buffers	cypress.com/go/clocks
Interface	cypress.com/go/interface
Lighting & Power Control	cypress.com/go/powerpsoc cypress.com/go/plc
Memory	cypress.com/go/memory
PSoC	cypress.com/go/psoc
Touch Sensing	cypress.com/go/touch
USB Controllers	cypress.com/go/USB
Wireless/RF	cypress.com/go/wireless

PSoC[®] Solutions

[psoc.cypress.com/solutions](#)
[PSoC 1](#) | [PSoC 3](#) | [PSoC 4](#) | [PSoC 5LP](#)

Cypress Developer Community

[Community](#) | [Forums](#) | [Blogs](#) | [Video](#) | [Training](#)

Technical Support

[cypress.com/go/support](#)

© Cypress Semiconductor Corporation, 2006-2013. The information contained herein is subject to change without notice. Cypress Semiconductor Corporation assumes no responsibility for the use of any circuitry other than circuitry embodied in a Cypress product. Nor does it convey or imply any license under patent or other rights. Cypress products are not warranted nor intended to be used for medical, life support, life saving, critical control or safety applications, unless pursuant to an express written agreement with Cypress. Furthermore, Cypress does not authorize its products for use as critical components in life-support systems where a malfunction or failure may reasonably be expected to result in significant injury to the user. The inclusion of Cypress products in life-support systems application implies that the manufacturer assumes all risk of such use and in doing so indemnifies Cypress against all charges.

Any Source Code (software and/or firmware) is owned by Cypress Semiconductor Corporation (Cypress) and is protected by and subject to worldwide patent protection (United States and foreign), United States copyright laws and international treaty provisions. Cypress hereby grants to licensee a personal, non-exclusive, non-transferable license to copy, use, modify, create derivative works of, and compile the Cypress Source Code and derivative works for the sole purpose of creating custom software and or firmware in support of licensee product to be used only in conjunction with a Cypress integrated circuit as specified in the applicable agreement. Any reproduction, modification, translation, compilation, or representation of this Source Code except as specified above is prohibited without the express written permission of Cypress.

Disclaimer: CYPRESS MAKES NO WARRANTY OF ANY KIND, EXPRESS OR IMPLIED, WITH REGARD TO THIS MATERIAL, INCLUDING, BUT NOT LIMITED TO, THE IMPLIED WARRANTIES OF MERCHANTABILITY AND FITNESS FOR A PARTICULAR PURPOSE. Cypress reserves the right to make changes without further notice to the materials described herein. Cypress does not assume any liability arising out of the application or use of any product or circuit described herein. Cypress does not authorize its products for use as critical components in life-support systems where a malfunction or failure may reasonably be expected to result in significant injury to the user. The inclusion of Cypress' product in a life-support systems application implies that the manufacturer assumes all risk of such use and in doing so indemnifies Cypress against all charges.

Use may be limited by and subject to the applicable Cypress software license agreement.