

Bluetooth® Low Energy (BLE) Module

Features

- Bluetooth SIG 4.2 qualified
- Certified to FCC, IC, MIC, KCC, NCC and SRRC radio regulations
- European R&TTE Directive Assessed Radio module
- RoHS compliant
- UART, I²C, and SPI interface supported
- Supports transparent UART data service of BLE
- Built around Microchip IS187x SoC
- BM70 supports 3-channel PWM and BM71 supports 1-channel PWM
- Precision Temperature Sensor (PTS) with operating range of -20°C ~ +70°C with an accuracy of ±3°C
- 12-bit ADC (ENOB=10/8-bits) support for battery and voltage detection.
- 8-channel ADC for BM70 and 5-channel ADC for BM71 is provided
- 18 general purpose I/O pins (BM70) and 9 general purpose I/O pins (BM71)
- Integrated 32 MHz crystal
- Small and compact surface mount module
- Castellated SMT pads for easy and reliable PCB mounting

RF Features

- ISM Band 2.402 GHz to 2.480 GHz operation
- Channels: 0-39
- Receive Sensitivity: typical -90 dBm (LE)
- Transmit Power: 0 dBm (typical)
- Received Signal Strength Indication (RSSI) monitor with 1 db resolution

MAC/Baseband/Higher Layer Features

- Secure AES128 encryption
- GAP, GATT, SM, L2CAP and integrated public profile
- Create custom services using User Interface (UI) tool, a Windows® configuration utility
- I/O capability for BT4.0/BT4.2 authentication
- Software configurable role as peripheral/central, client/server

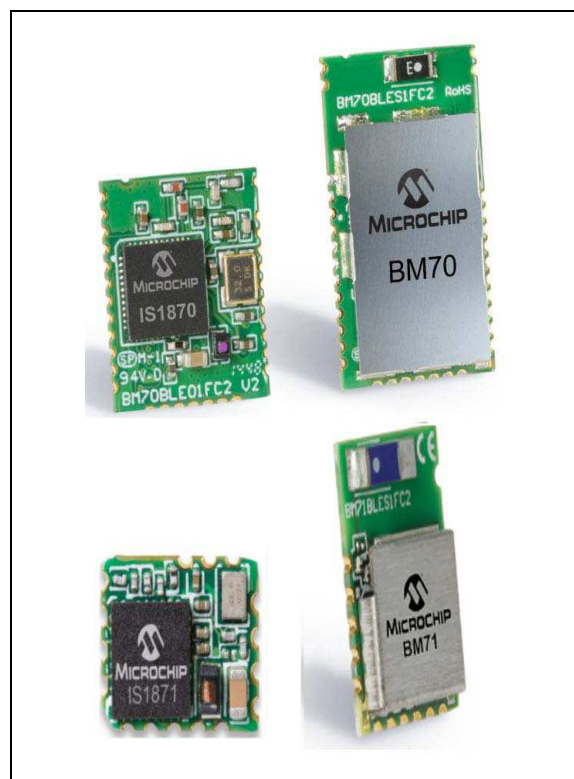

Note: These images are for the representation purpose only and the original product might differ in markings.

Antenna

- Integrated chip antenna (BM7xBLES1FC2)
- External antenna connection through RF pad (BM7xBLE01FC2)

Power Management

- Low-power modes supported, system wake-up through any GPIO
- Peak current: Tx 13 mA and Rx 13 mA with buck at 3.0V VBAT input

Operating Conditions

- Operating voltage range: 1.9V to 3.6V
- Operating temperature: -20°C to +70°C

BM70/71

General Description

The BM70/71 module offers Bluetooth Low Energy solution for embedded applications. It conforms to the Bluetooth core specification version 4.2 to enhance the throughput and security for the IoT applications. It also supports Beacon technology to enhance user experience for the IoT applications and enables users to control the cloud and receive data without opening the application through a smart phone.

The BM70/71 has Bluetooth stack integrated and is available in different form factor to optimize the space, cost, and RF performance. For portable and wearable applications, it provides power-optimized design to minimize the current consumption to extend the battery life.

Applications

- Internet of Things (IoT)
- Payment or Security
- Wearable Devices
- Home and Security
- Health and Fitness
- Beacons
- Industrial and Data Logger

Table of Contents

1.0 Device Overview	5
2.0 Application information	13
3.0 Module Configuration	25
4.0 Antenna	27
5.0 Electrical Characteristics	35
6.0 Packaging Information	41
7.0 Soldering Recommendations	49
8.0 Ordering Guide	51
Appendix A: Certification Notices	53
Appendix B: Revision History	59

TO OUR VALUED CUSTOMERS

It is our intention to provide our valued customers with the best documentation possible to ensure successful use of your Microchip products. To this end, we will continue to improve our publications to better suit your needs. Our publications will be refined and enhanced as new volumes and updates are introduced.

If you have any questions or comments regarding this publication, please contact the Marketing Communications Department via E-mail at docerrors@microchip.com or fax the **Reader Response Form** in the back of this data sheet to (480) 792-4150. We welcome your feedback.

Most Current Data Sheet

To obtain the most up-to-date version of this data sheet, please register at our Worldwide Web site at:

<http://www.microchip.com>

You can determine the version of a data sheet by examining its literature number found on the bottom outside corner of any page. The last character of the literature number is the version number, (e.g., DS30000000A is version A of document DS30000000).

Errata

An errata sheet, describing minor operational differences from the data sheet and recommended workarounds, may exist for current devices. As device/documentation issues become known to us, we will publish an errata sheet. The errata will specify the revision of silicon and revision of document to which it applies.

To determine if an errata sheet exists for a particular device, please check with one of the following:

- Microchip's Worldwide Web site; <http://www.microchip.com>
- Your local Microchip sales office (see last page)

When contacting a sales office, please specify which device, revision of silicon and data sheet (include literature number) you are using.

Customer Notification System

Register on our web site at www.microchip.com to receive the most current information on all of our products.

BM70/71

NOTES:

1.0 DEVICE OVERVIEW

The BM70/71 embedded 2.4 GHz Bluetooth version 4.2 BLE module is built around Microchip Technology IS1870/71 BLE System on Chip (SoC). The IS1870/71 SoC incorporates Bluetooth stack, power management subsystem, 2.4 GHz transceiver, and RF power amplifier. The user can embed Bluetooth functionality into any applications using the BM70/71 module.

The BM70/71 enables faster product development and time to market. It is designed to provide simple Bluetooth solutions with the following features:

- Simple integration and programming
- Reduced development time
- Superior wireless module with low-cost system
- Interoperability with Apple® iOS and Android™ OS
- Wide range of applications

In addition, the BM70/71 supports Beacon technology to improve user experiences in IoT applications, such as auto connection/control and data to cloud.

The BM70/71 can independently maintain a low-power wireless connection, and the low-power usage and flexible power management maximizes the module's lifetime in battery operated devices. Also, wide operating temperature range enables its use in indoor and outdoor environments.

The BM70/71 is a small, compact, surface mount on the host PCB with the castellated pads making the interface easy and reliable. The BM71 is relatively small form factor module targeted for applications, such as wearable sports, fitness devices and so on.

1.1 Interface Description

Figure 1-1 and Figure 1-2 illustrate an example of the BM70/71 module-based system. Figure 1-3 through Figure 1-6 illustrate the pin diagrams. Table 1-1 provides pin descriptions.

FIGURE 1-1: BM70-BASED SYSTEM BLOCK DIAGRAM

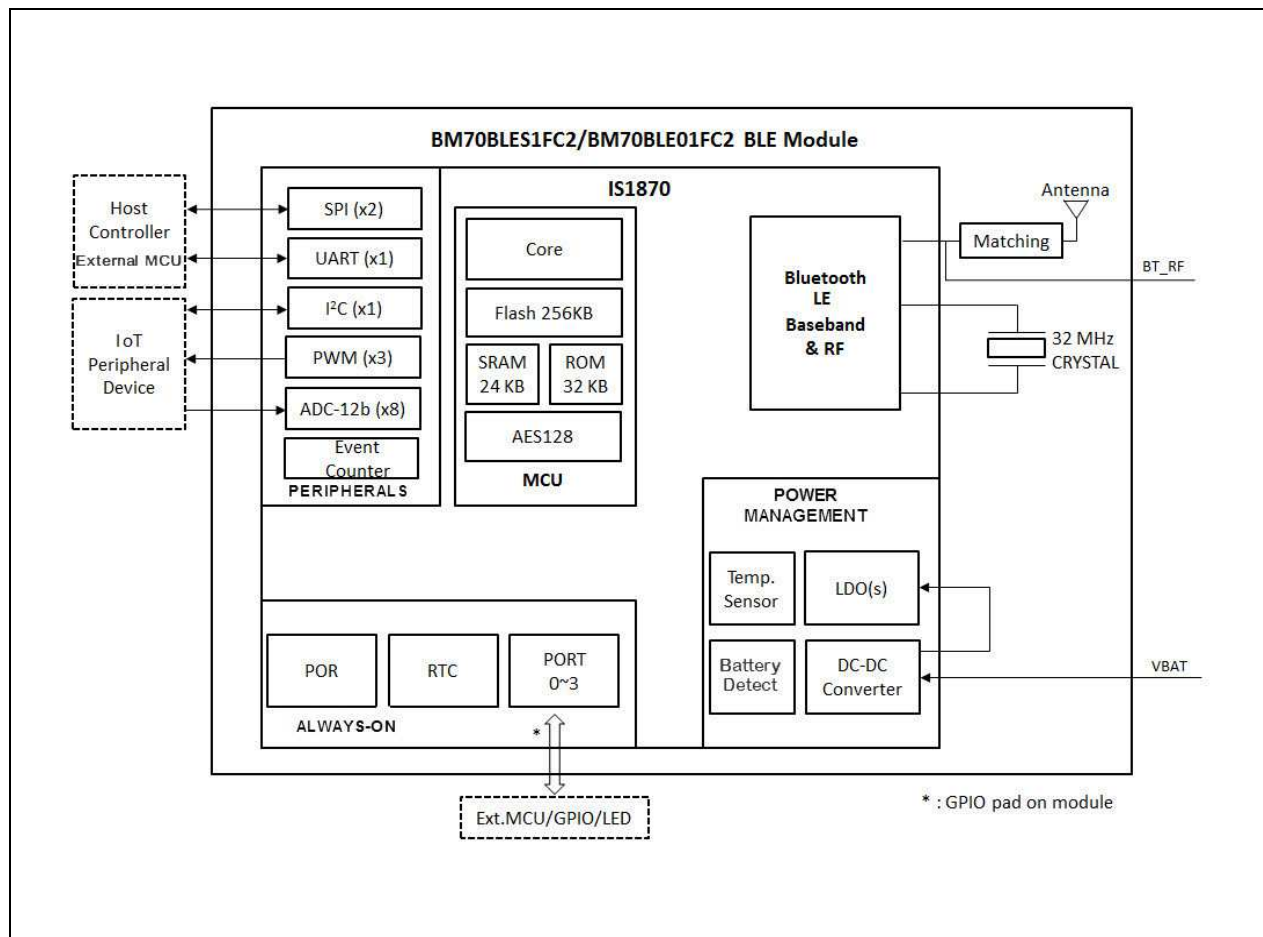

FIGURE 1-2: BM71-BASED SYSTEM BLOCK DIAGRAM

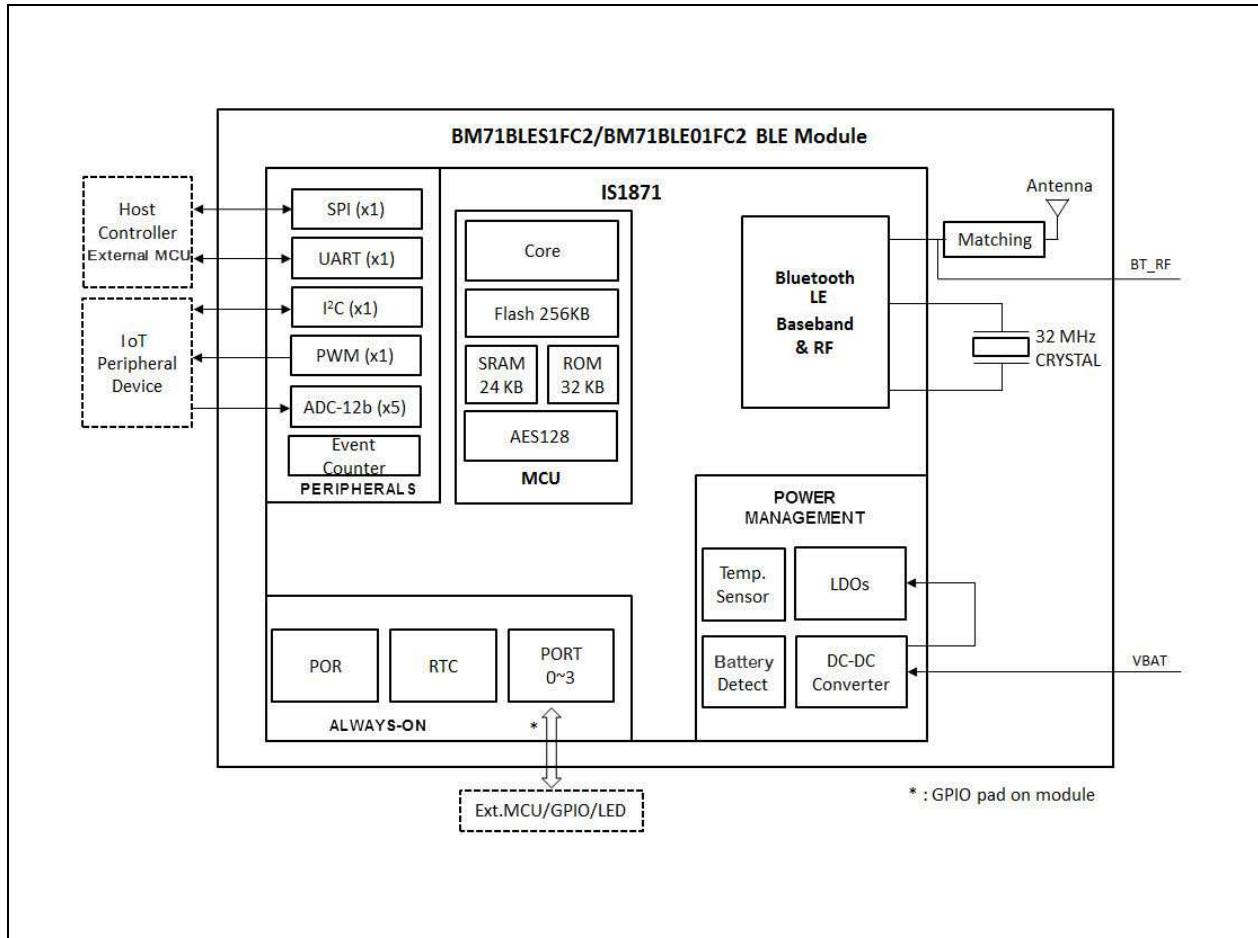

FIGURE 1-3: BM70BLE01FC2 PIN DIAGRAM

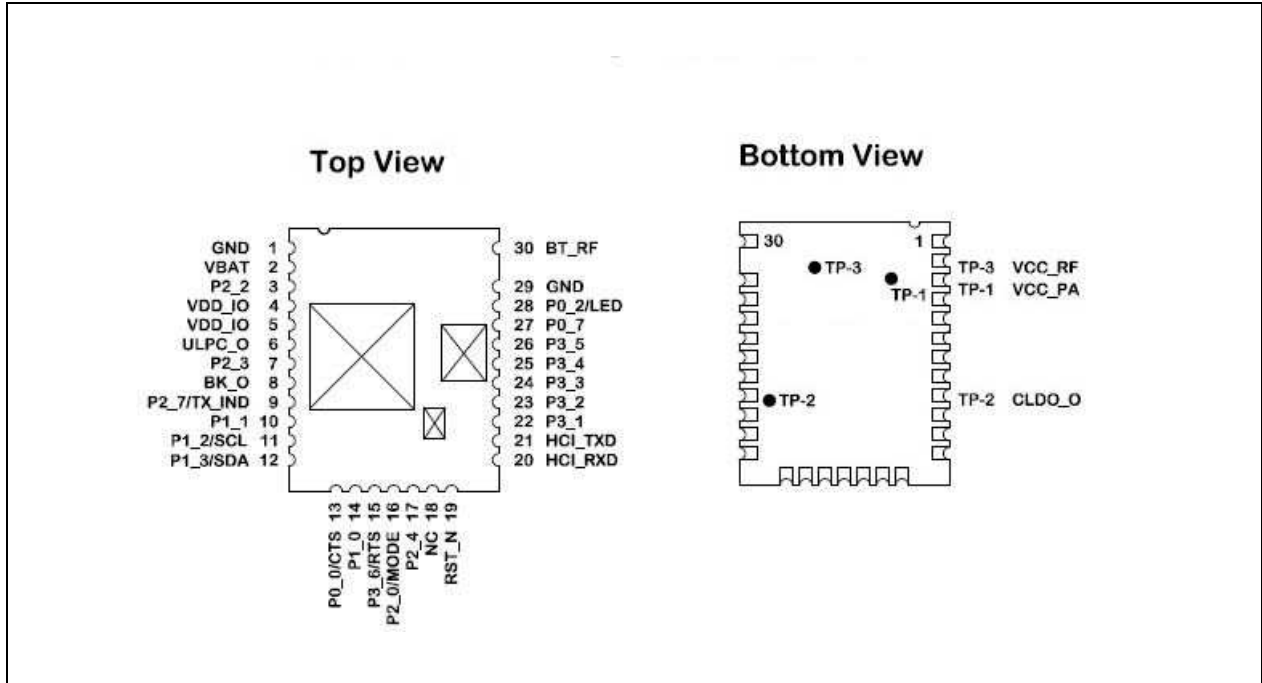
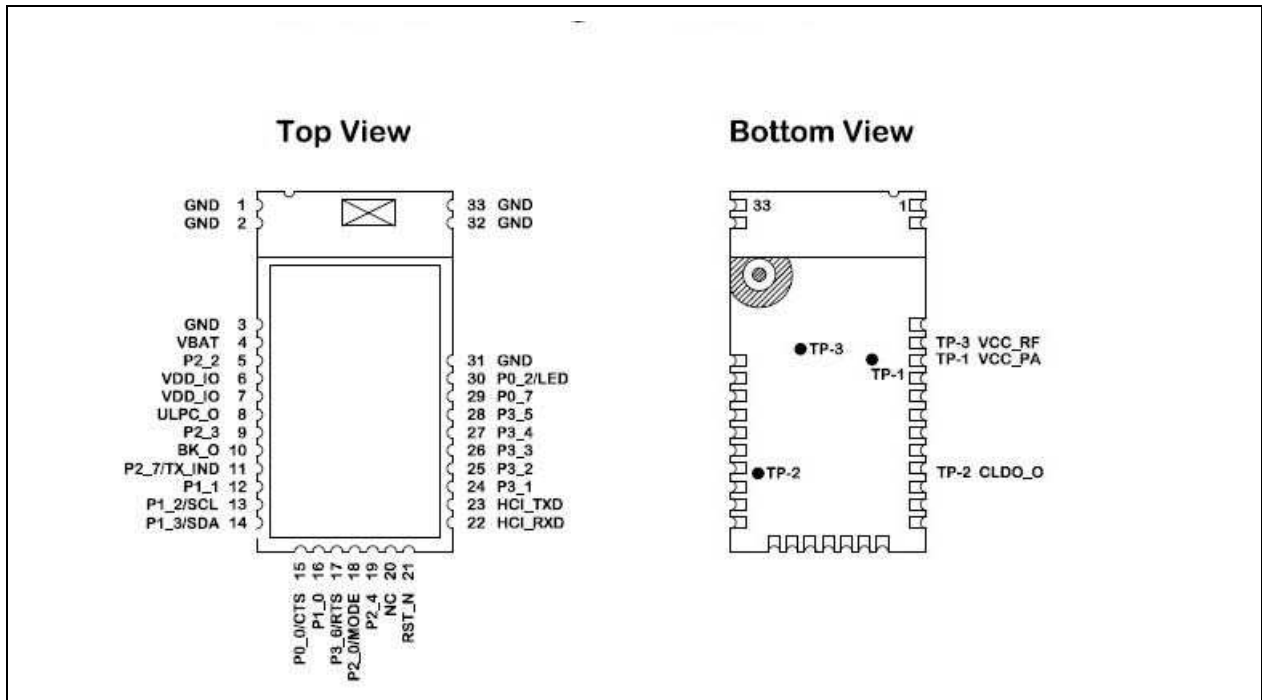

FIGURE 1-4: BM70BLES1FC2 PIN DIAGRAM



BM70/71

FIGURE 1-5: BM71BLE01FC2 PIN DIAGRAM

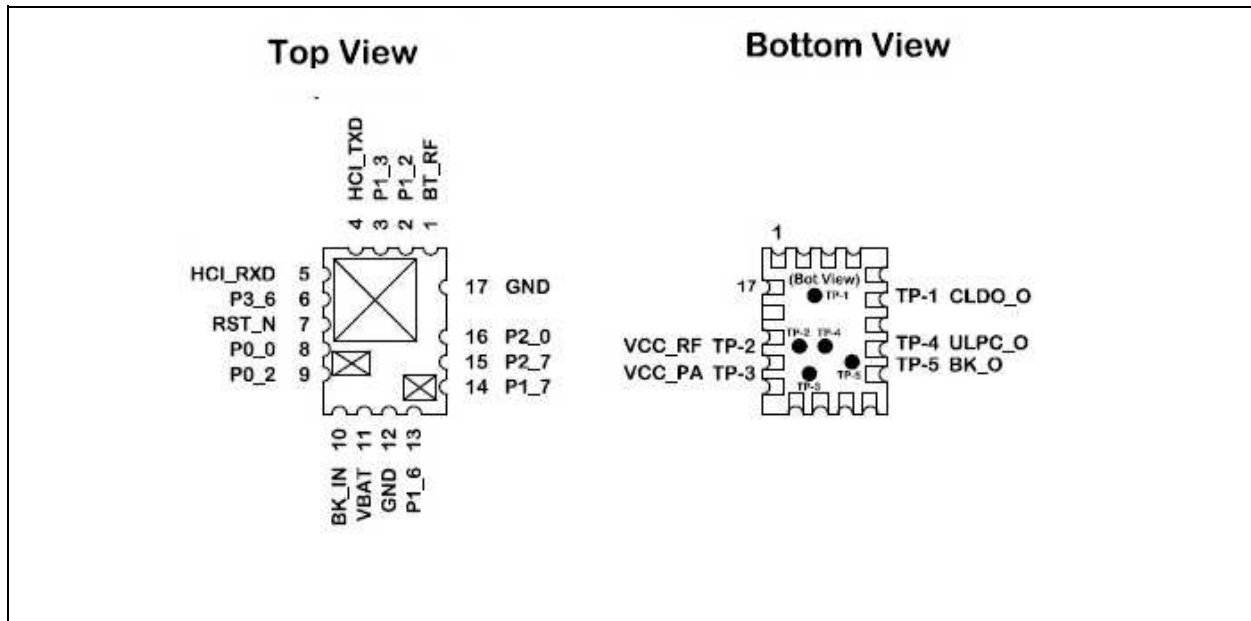

FIGURE 1-6: BM71BLES1FC2 PIN DIAGRAM

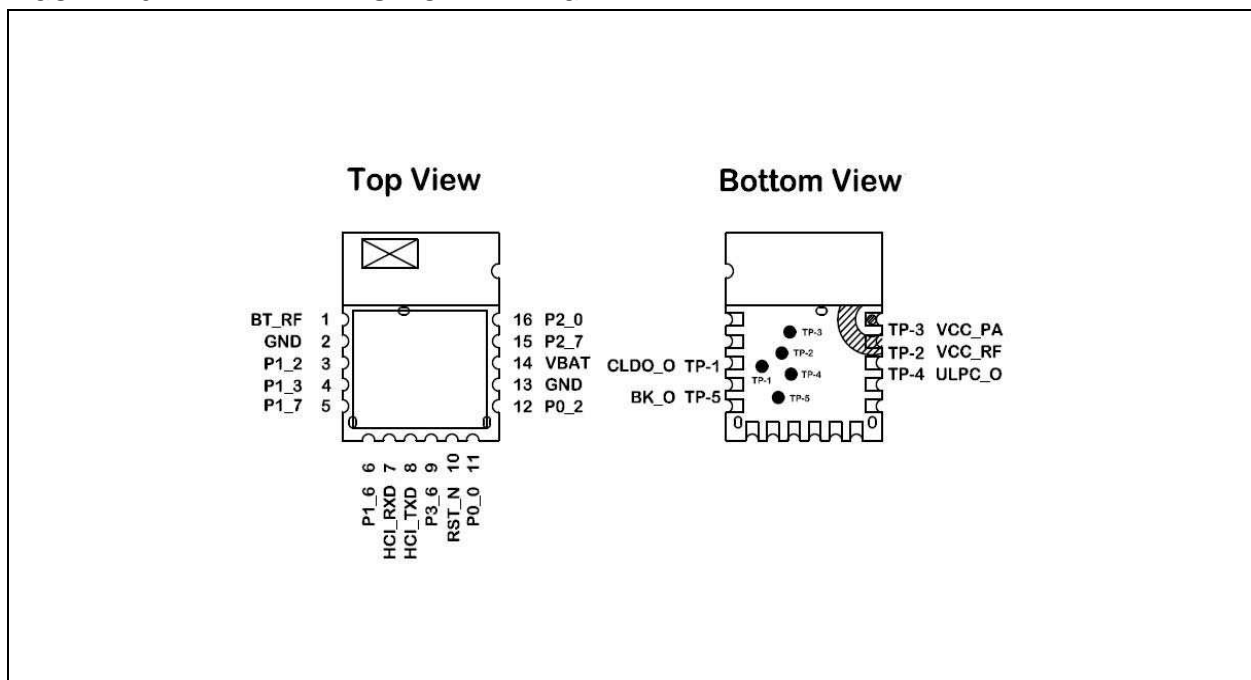

TABLE 1-1: PIN DESCRIPTION

BM70BLE01FC2	BM70BLE S1FC2	BM71BLE 01FC2	BM71BLE S1FC2	Pin Name	Type	Description
—	1	—	—	GND	Power	Ground reference
—	2	—	—	GND	Power	Ground reference
1	3	12	13	GND	Power	Ground reference
2	4	11	14	VBAT	Power	Battery input. Voltage range: 1.9V to 3.6V
—	—	10	—	BK_IN	Power	Buck input. Voltage range: 1.9V to 3.6V
3	5	—	—	P2_2	DIO	GPIO, default pull-high input PWM1
4	6	—	—	VDD_IO	Power	I/O positive supply. Do not connect. Ensure VDD_IO and MCU I/O voltage are compatible
5	7	—	—	VDD_IO	Power	I/O positive supply. Do not connect. Ensure VDD_IO and MCU I/O voltage are compatible
6	8	—	—	ULPC_O	Power	1.2V programmable ULPC LDO output for AON-logic and retention memory supply. Internal use only, do not connect to other devices.
7	9	—	—	P2_3	DI	GPIO, default pull-high input PWM2
8	10	—	—	BK_O	Power	1.55V buck output. internal use only, do not connect to other devices.
—	—	13	6	P1_6	DIO AI	P1_6 External 32.768 kHz crystal input: X132K
—	—	14	5	P1_7	DIO AO	P1_7 External 32.768 kHz crystal output: XO32K
9	11	15	15	P2_7	DIO AI DO DO	GPIO: P2_7 ADC Input: AD14 TX_IND SPI bus: NCS2, second SPI bus (Master mode)
10	12	—	—	P1_1	DIO AI DI	GPIO: P1_1 ADC Input: AD9 SPI bus: MISO2, second SPI bus (Master mode)
11	13	2	3	P1_2	DIO AI I/O	GPIO, default pull-high input AD10 I ² C SCL
12	14	3	4	P1_3	DIO AI DIO	GPIO, default pull-high input AD11 I ² C SDA
13	15	8	11	P0_0	DIO AI DI	GPIO, default pull-high input AD0 UART flow-control CTS
14	16	—	—	P1_0	DIO AI	GPIO, default pull-high input AD8
15	17	6	9	P3_6	DIO DO DO	GPIO, default pull-high input PWM0 UART flow-control RTS

Legend: A = Analog D = Digital I = Input O = Output

BM70/71

BM70BLE01FC2	BM70BLE S1FC2	BM71BLE 01FC2	BM71BLE S1FC2	Pin Name	Type	Description
16	18	16	16	P2_0	DI	System configuration, default pull-high input H: Application mode L: Test mode
17	19	—	—	P2_4	DIO	GPIO, default pull-high input
18	20	—	—	NC	—	No connection
19	21	7	10	RST_N	DI	Module Reset (active-low) (internal pull-up)
20	22	5	7	HCI_RXD	DI	HCI UART data input
21	23	4	8	HCI_TXD	DO	HCI UART data output
22	24	—	—	P3_1	DIO DO	GPIO: P3_1 SPI bus: NCS, SPI Flash: CSN
23	25	—	—	P3_2	DIO DO	GPIO: P3_2 SPI bus: MISO, SPI Flash: SDO
24	26	—	—	P3_3	DIO DI	GPIO: P3_3 SPI bus: MOSI, SPI Flash: SDI
25	27	—	—	P3_4	DIO DO	GPIO: P3_4 SPI bus: SCLK, SPI Flash: SCK
26	28	—	—	P3_5	DIO DO	GPIO, default pull-high input LED1
27	29	—	—	P0_7	DIO AI	GPIO, default pull-high input AD7
28	30	9	12	P0_2/LED	DIO AI	P02 AD2
29	31	17	2	GND	Power	Ground reference
—	32	—	—	GND	Power	Ground reference
30	—	1	1	BT_RF	AI	External antenna connection (50 Ohm) Only for BM70BLE01FC2 and BM71BLE01FC2 NC for BM71BLES1FC2
—	33	—	—	GND	Power	Ground reference

Legend: A = Analog D = Digital I = Input O = Output

Table 1-2 provides the BM70/71 and BLE Development Kit Version 3 (BLEDK3) features.

Note: The BLEDK3 application is one of the application firmwares of the BM70/71. For more information on the BLEDK3 application, refer to the “*IS187x_BM7x BLEDK3 Application Note*”.

TABLE 1-2: BM70/71 HARDWARE AND BLEDK3 FEATURES⁽¹⁾

Feature/ Modules	BM70BLES1FC2		BM70BLE01FC2		BM71BLES1FC2		BM71BLE01FC2	
	Module H/W	BLEDK3	Module H/W	BLEDK3	Module H/W	BLEDK3	Module H/W	BLEDK3
UART	1	1	1	1	1	1	1	1
GPIO (see Note 2)	18	13	18	13	9	4	9	4
12-bit ADC Channels	8	6	8	6	5	3	5	3
PWM	3	2	3	2	1	0	1	0
SPI	2	0	2	0	1	0	1	0
I ² C	1	0	1	0	1	0	1	0
Total Pins	33	—	30	—	16	—	17	—
On-board Antenna with Shielded Can	Yes	—	—	—	Yes	—	—	—
No Antenna	—	—	Yes	—	—	—	Yes	—
Government Regulatory RF Certified	Yes	—	—	—	Yes	—	—	—
Size (mm)	12x22x2.4	—	12x15x1.6	—	9x11.5x2.1	—	6x8x1.6	—

Note 1: The GPIO, ADC and PWM pin numbers in the BLEDK3 application is calculated by taking out the default pins of UART peripherals and LED indication, which are listed in Table 1-4.

2: For detailed GPIO configuration example for the BLEDK3 Manual Pattern, refer to the "*BLEDK3 Manual Pattern User's Guide*".

BM70/71

Table 1-3 provides the details of the test pads used for the production test on the bottom of the BM70/71.

Table 1-4 provides GPIO pins and its connection details.

TABLE 1-3: TEST PADS DETAILS

BM70BLE 01FC2	BM70BLE S1FC2	BM71BLE 01FC2	BM71BLE S1FC2	Pin Name	Type	Description
TP-1	TP-1	TP-3	TP-3	VCC_PA	Power	1.55V RF PA LDO
TP-2	TP-2	TP-1	TP-1	CLDO_O	Power	1.2V CLDO output
TP-3	TP-3	TP-2	TP-2	VCC_RF	Power	1.28V RF LDO output
—	—	TP-4	TP-4	ULPC_O	Power	1.2V ULPC LDO output
—	—	TP-5	TP-5	BK_O	Power	1.55V buck output

TABLE 1-4: GPIO PIN DETAILS

GPIO Pins	Connection details
P2_0	System configuration
P0_2	LED0
P0_0	UART_CTS
P2_7	UART_RX_IND
P3_6	UART_RTS

2.0 APPLICATION INFORMATION

2.1 Reference Schematics

Figure 2-1 through Figure 2-4 illustrate the BM70/71 reference circuits for various Stock Keeping Units (SKUs). The GPIOs are configurable and the connection depends on the user's application circuit.

The power input range is 1.9V~3.6V. If the battery is used, the battery reverse protection circuit is recommended. The VDD_IO voltage is same as power input. If the LED is used, ensure that the voltage is more than 3V to drive the LED. A 1.8V Reset IC is added as an optional circuit to prevent the Flash data crash when VBAT power is unstable. It is recommended to implement the RF antenna matching circuit as illustrated in Figure 2-3 and Figure 2-5 to fine tune the antenna impedance matching.

FIGURE 2-1: BM70BLES1FC2 REFERENCE CIRCUIT

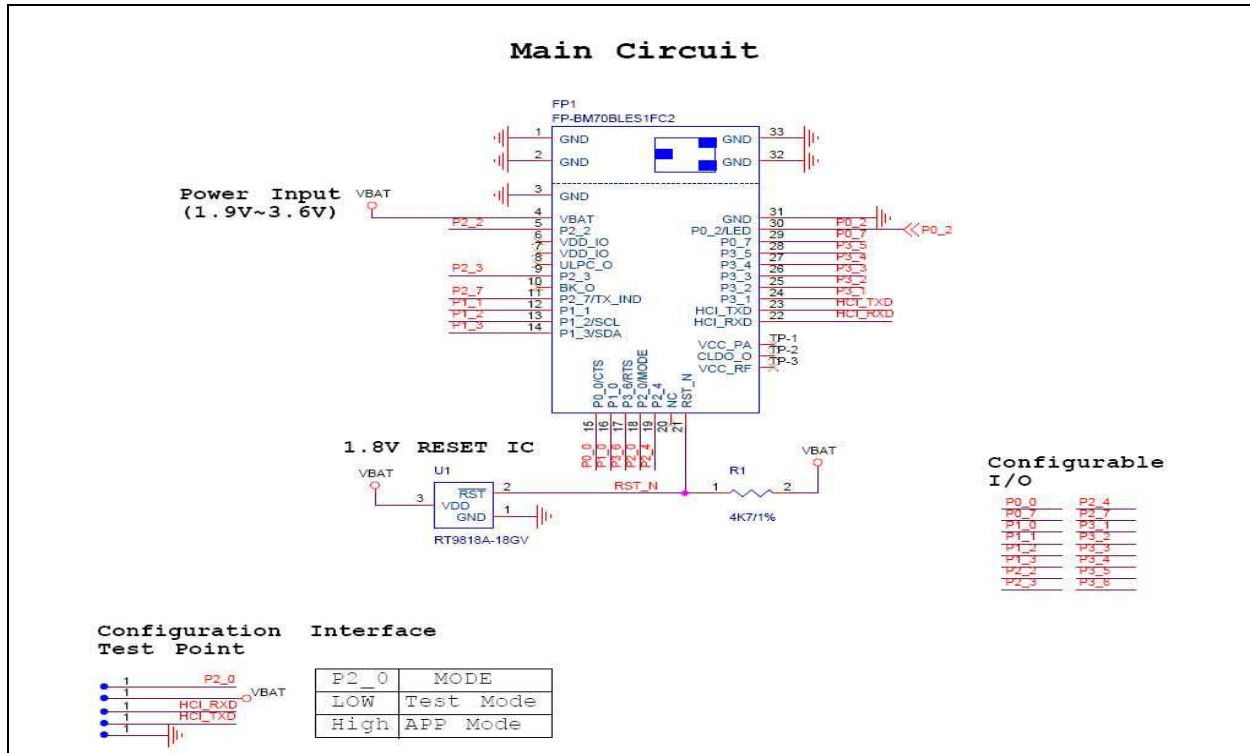
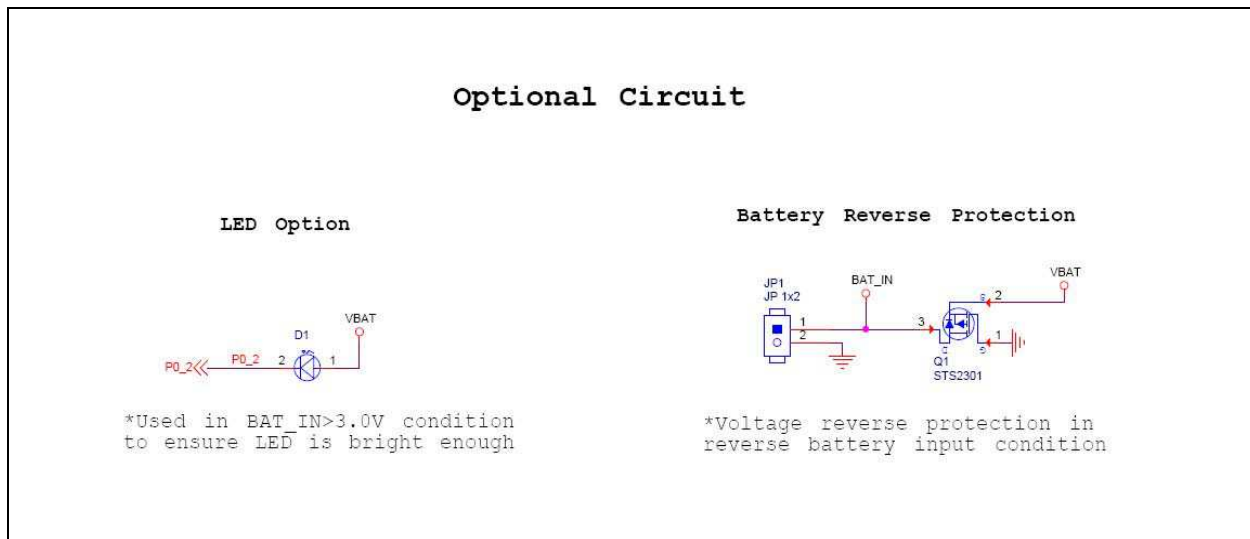

FIGURE 2-2: BM70BLES1FC2 REFERENCE CIRCUIT



BM70/71

FIGURE 2-3: BM70BLE01FC2 REFERENCE CIRCUIT

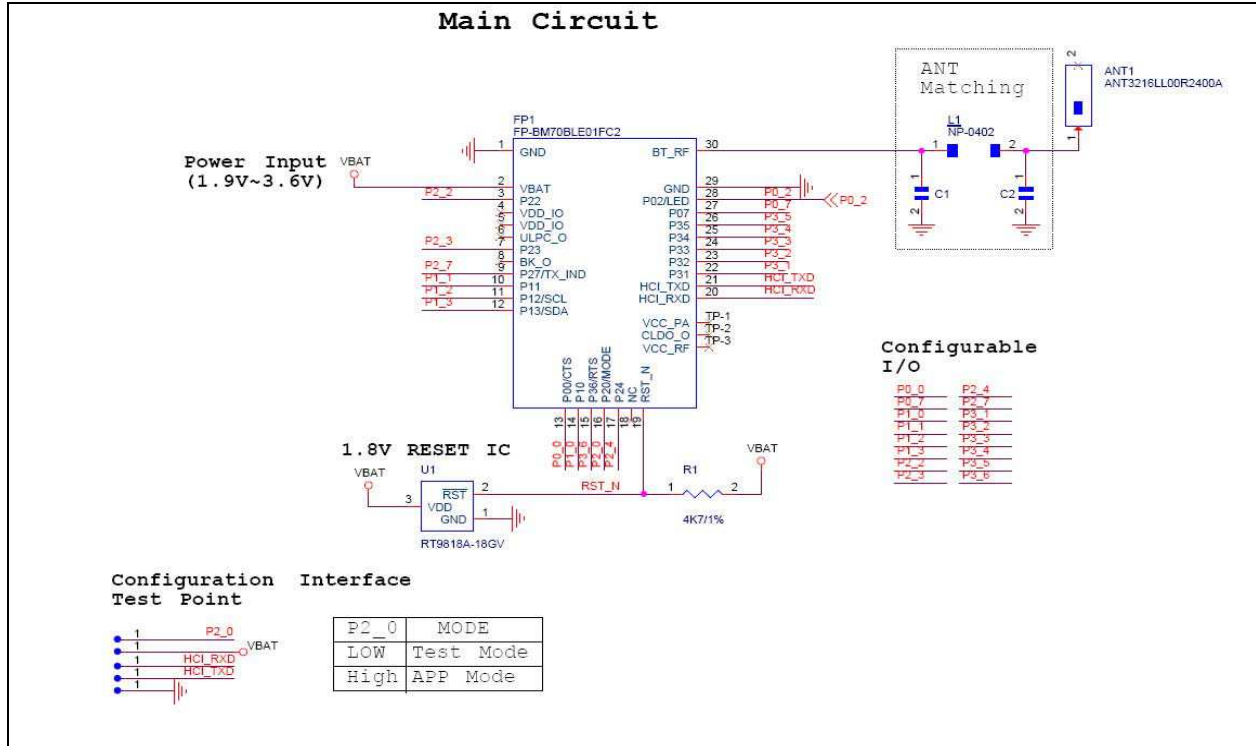

FIGURE 2-4: BM70BLE01FC2 REFERENCE CIRCUIT

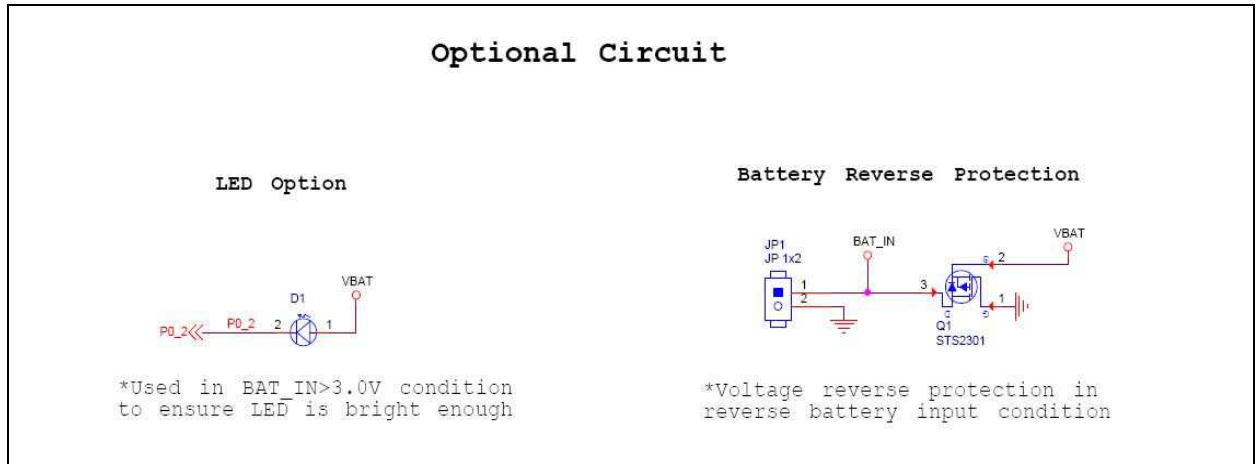
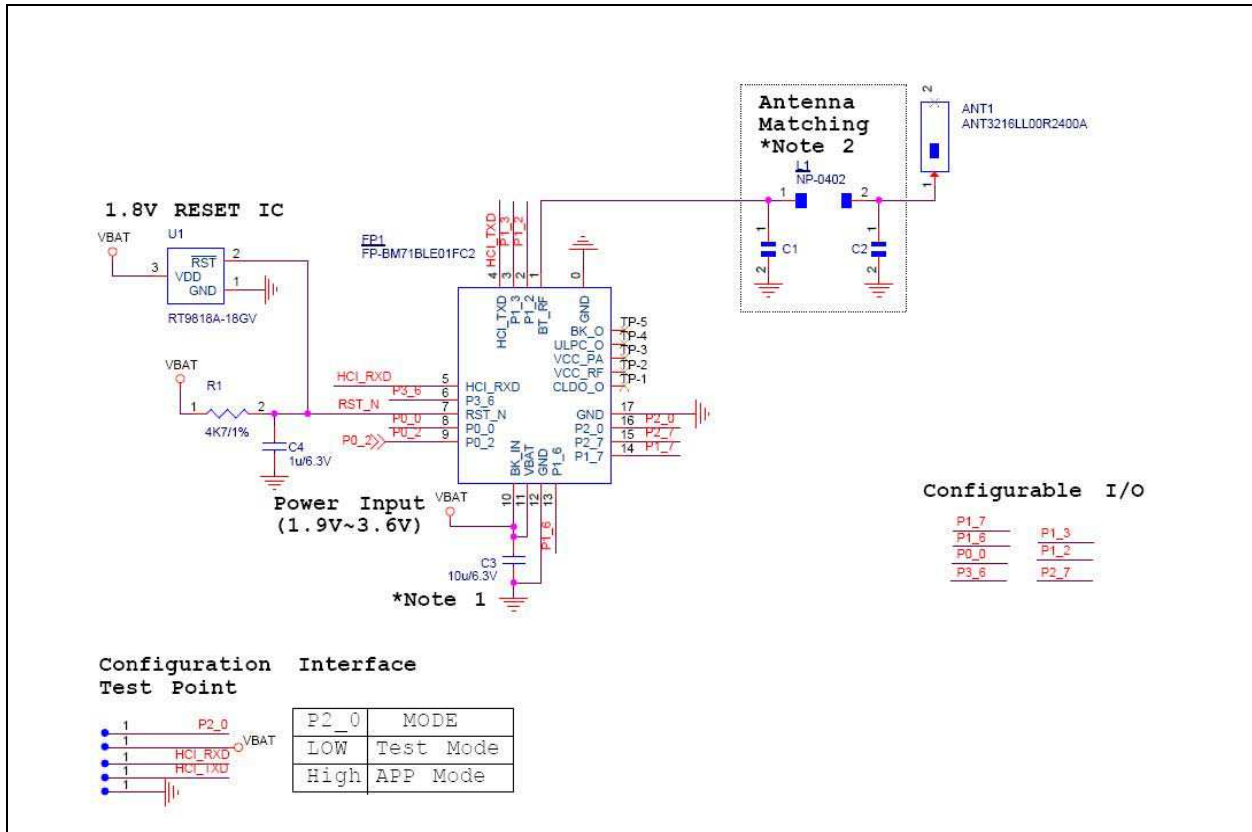

FIGURE 2-5: BM71BLE01FC2 REFERENCE CIRCUIT



- Note 1:** Place the capacitor C3 as close as possible to the module. Connect the BK_IN and VBAT trace at C3.
- 2:** The antenna matching component value depends on the user's antenna and PCB layout.

FIGURE 2-6: BM71BLE01FC2 REFERENCE CIRCUIT

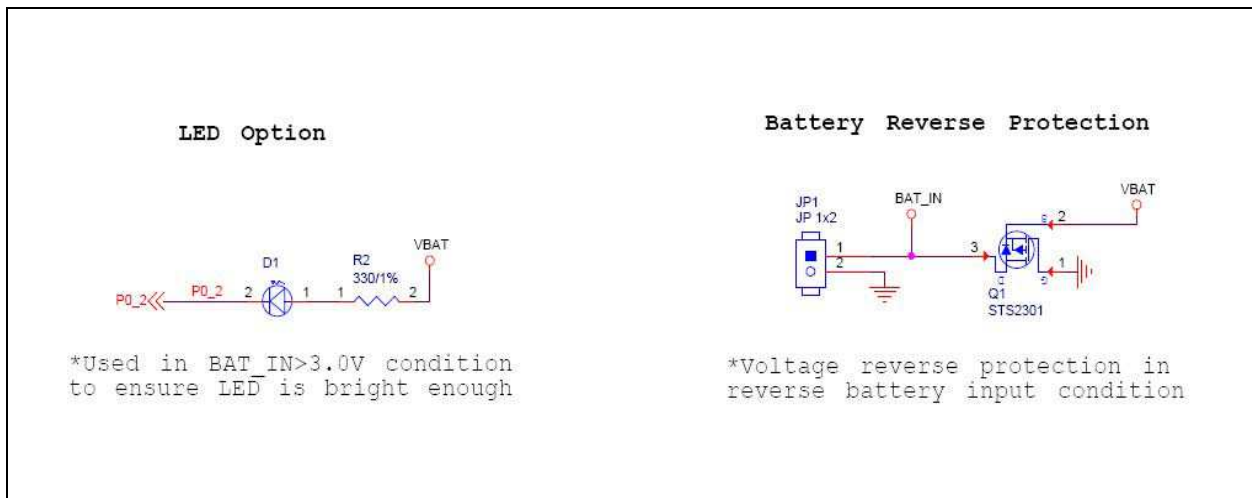
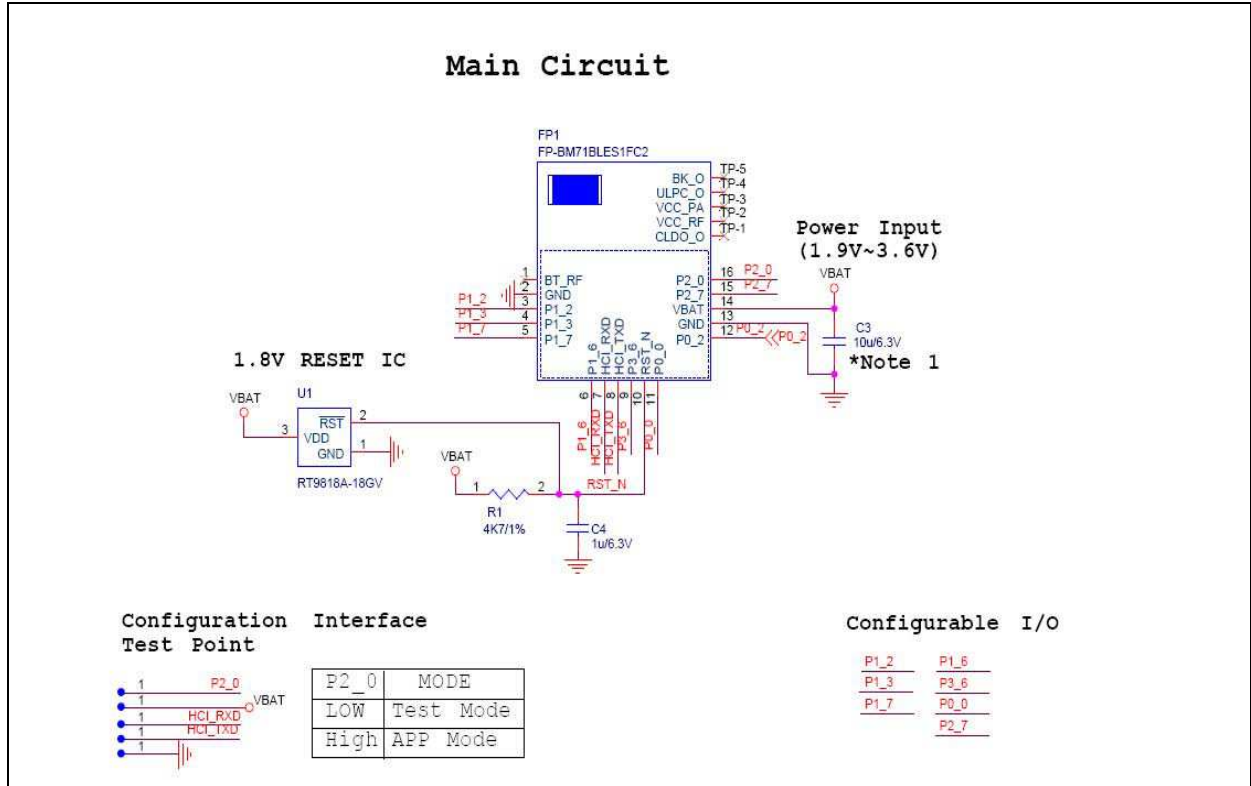
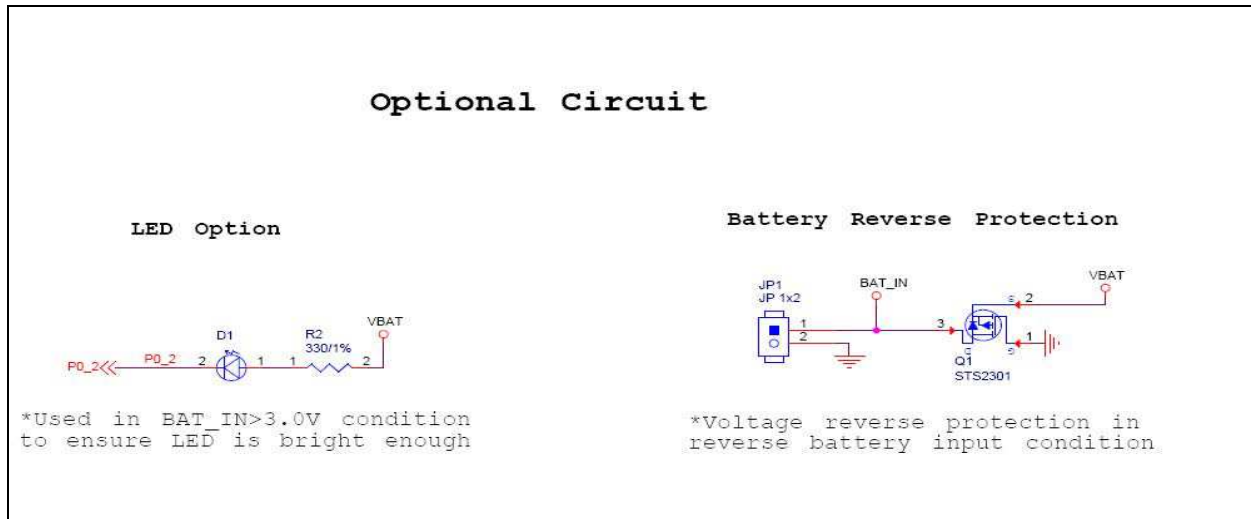

FIGURE 2-7: BM71BLES1FC2 REFERENCE CIRCUIT



Note 1: Place the capacitor C3 as close as possible to the module.

FIGURE 2-8: BM71BLES1FC2 REFERENCE CIRCUIT - OPTIONAL



2.2 External Configuration and Programming

The BM70/71 can be configured and programmed using an external configuration and programming tool. [Figure 2-9](#) illustrates the test points that must be included on the host PCB for the development.

Configuration and programming modes can be entered according to the system configuration I/O pins. For additional information, refer to [Section 3.4, System Configuration](#).

FIGURE 2-9: EXTERNAL CONFIGURATION AND PROGRAMMING

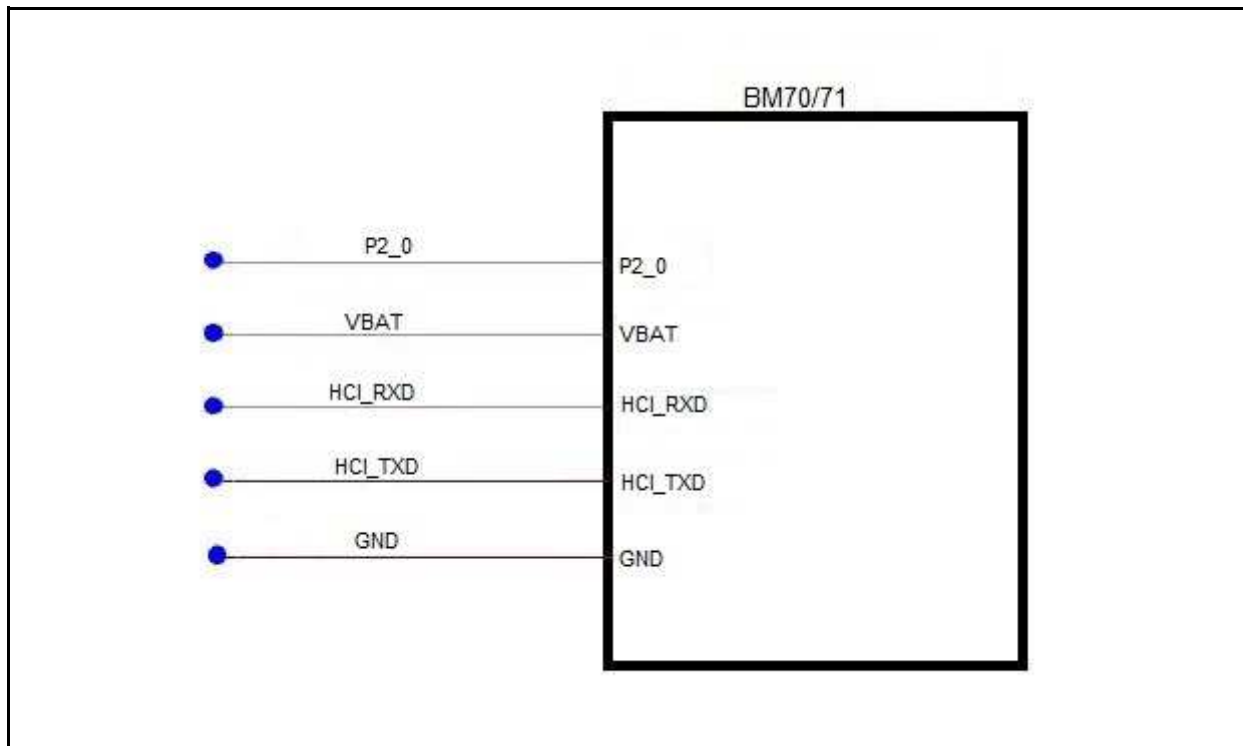

BM70/71

2.3 Host MCU Interface

2.3.1 HOST MCU INTERFACE OVER UART

Figure 2-10 and Figure 2-11 illustrate the BM70/71 to host MCU interface over UART. The Host Control Interface (HCI) UART lines are used to communicate

between the BM70/71 and MCU. The interface also illustrates the power scheme using a 3.3V Low-Drop Out (LDO) regulator that supply 3.3V to the BM70/71 (BAT_IN) and MCU VDD. This power scheme ensures that the BM70/71 and MCU I/O voltages are compatible.

FIGURE 2-10: BM70 TO MCU INTERFACE

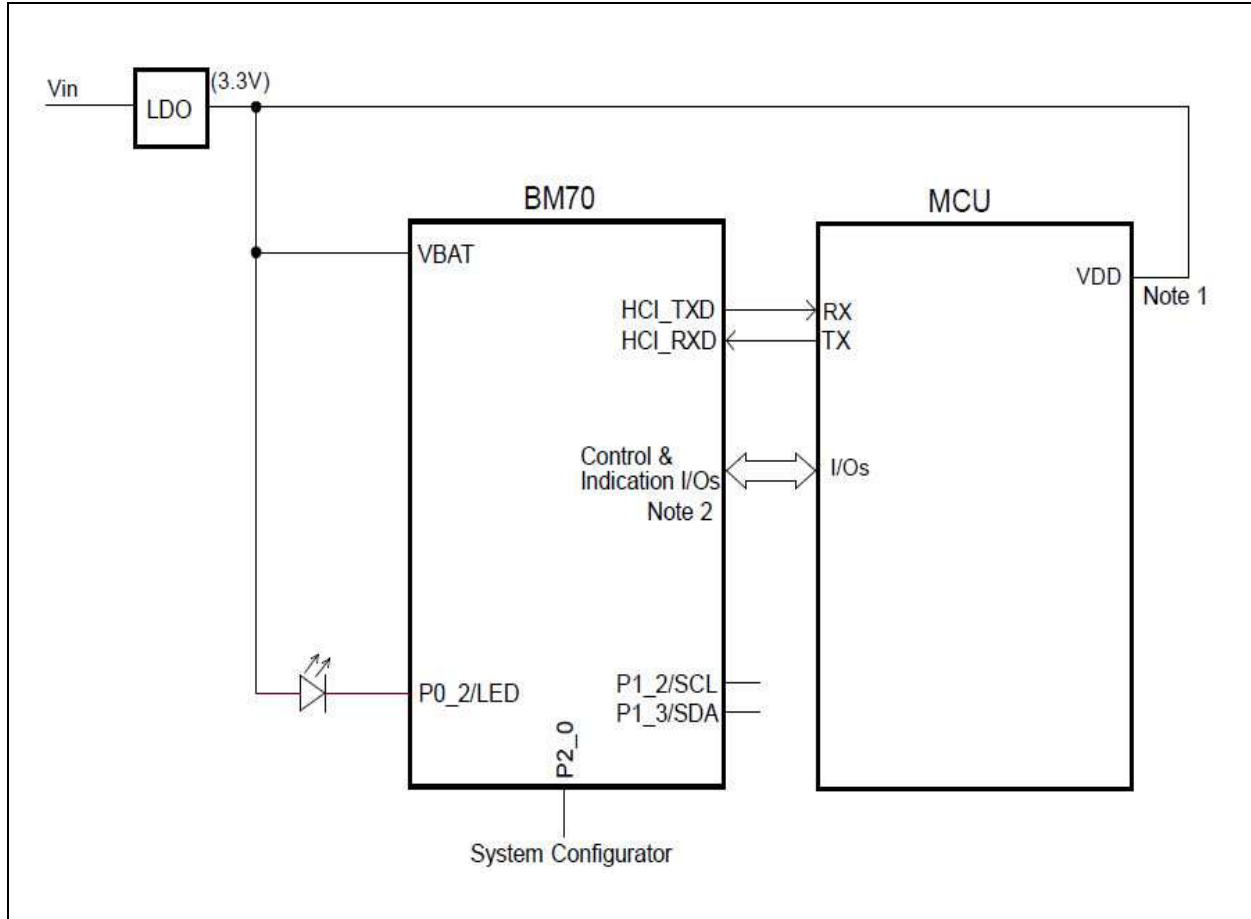

Note 1: Ensure that VBAT(=I/O Voltage) and MCU VDD voltages are compatible.

Note 2: Control and indication ports are configurable.

FIGURE 2-11: BM71 TO MCU INTERFACE

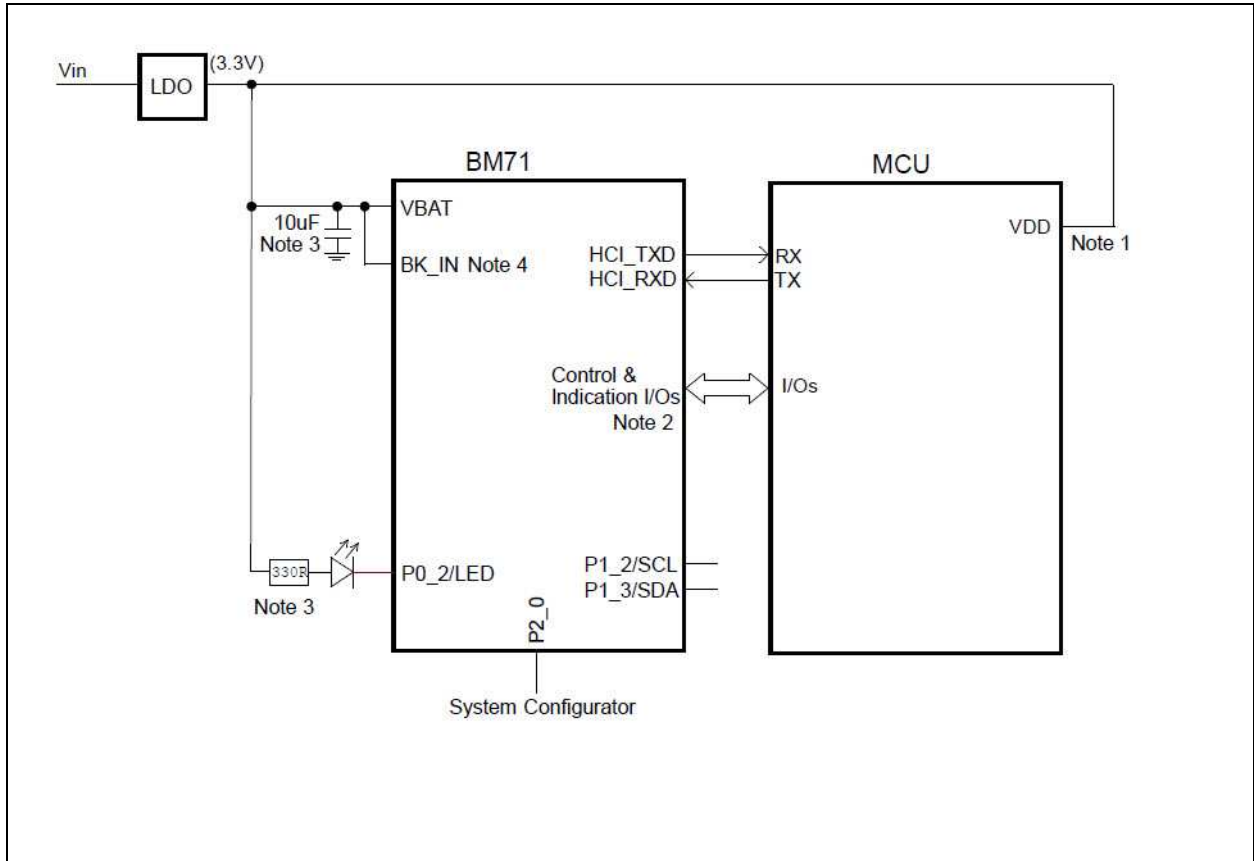

- Note 1:** Ensure that VBAT=I/O Voltage) and MCU VDD voltages are compatible.
- 2:** Control and indication ports are configurable.
- 3:** 10 μ F (X5R) and 330 Ohm resistor are required for the BM71 module.
- 4:** BK_IN connect to VBAT for BM71BLE01FC2.

BM70/71

2.3.2 UART READY AFTER EXTERNAL RESET

In MCU applications, the time between Reset/power-on and the BM70/71 UART port read must be notified. Figure 2-12 illustrates the timing of the BM70/71 UART port ready for Test mode and Application mode after Reset.

FIGURE 2-12: TIMING DIAGRAM OF BM70/71 UART READY FOR TEST MODE AFTER RESET

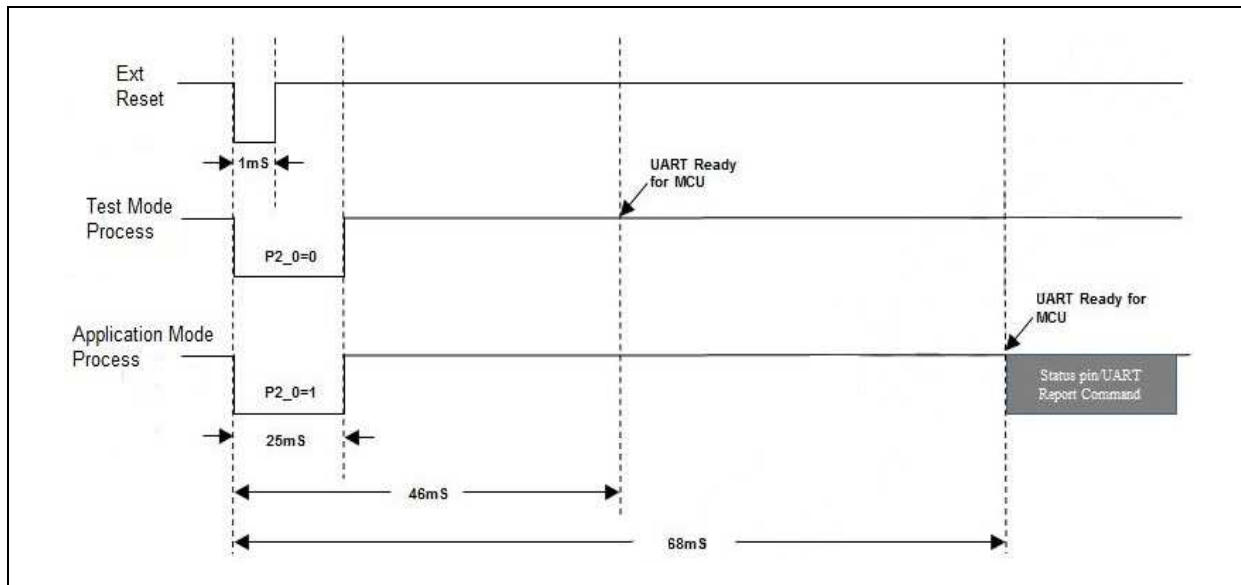

2.3.3 UART READY AFTER POWER-ON RESET

Figure 2-13 illustrates the timing of the BM70/71 UART port ready for Test mode and Application mode after Power-on Reset (POR).

In Application mode, when the BM70/71 is ready to communicate with the host MCU after Reset, the BM70/71 will have either Standby mode which is indi-

cated by the status pin, or a status report UART command which is sent to inform the MCU that the BM70/71 is ready for communication.

FIGURE 2-13: TIMING DIAGRAM OF BM70 UART READY FOR TEST MODE AFTER POWER ON

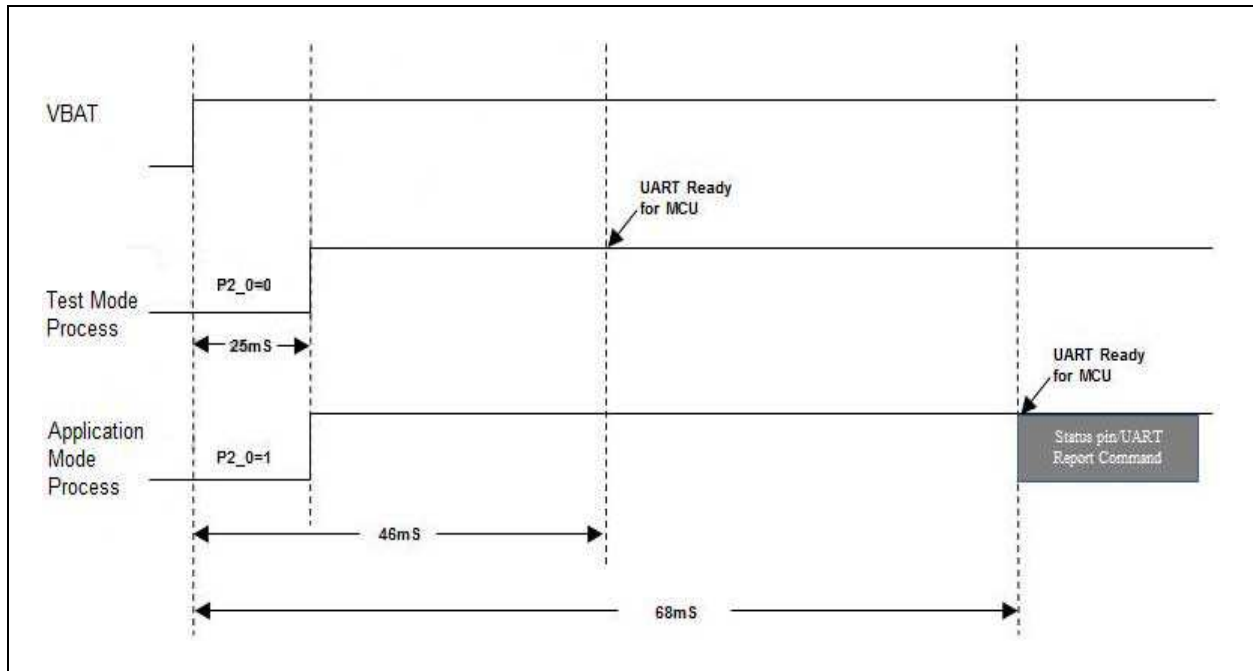

2.4 Standalone Configuration

Figure 2-14 illustrates the standalone configuration for the BM71BLE01FC2 module. It also illustrates an application using a coin cell battery at VBAT input. For

the BM71, a 10 μ F capacitor (X5R/X7R) is applied to the BAT_IN pin. The BK_IN pin of the BM71BLE01FC2 module must be connected to the BAT_IN pin.

FIGURE 2-14: BM71 STANDALONE CONFIGURATION

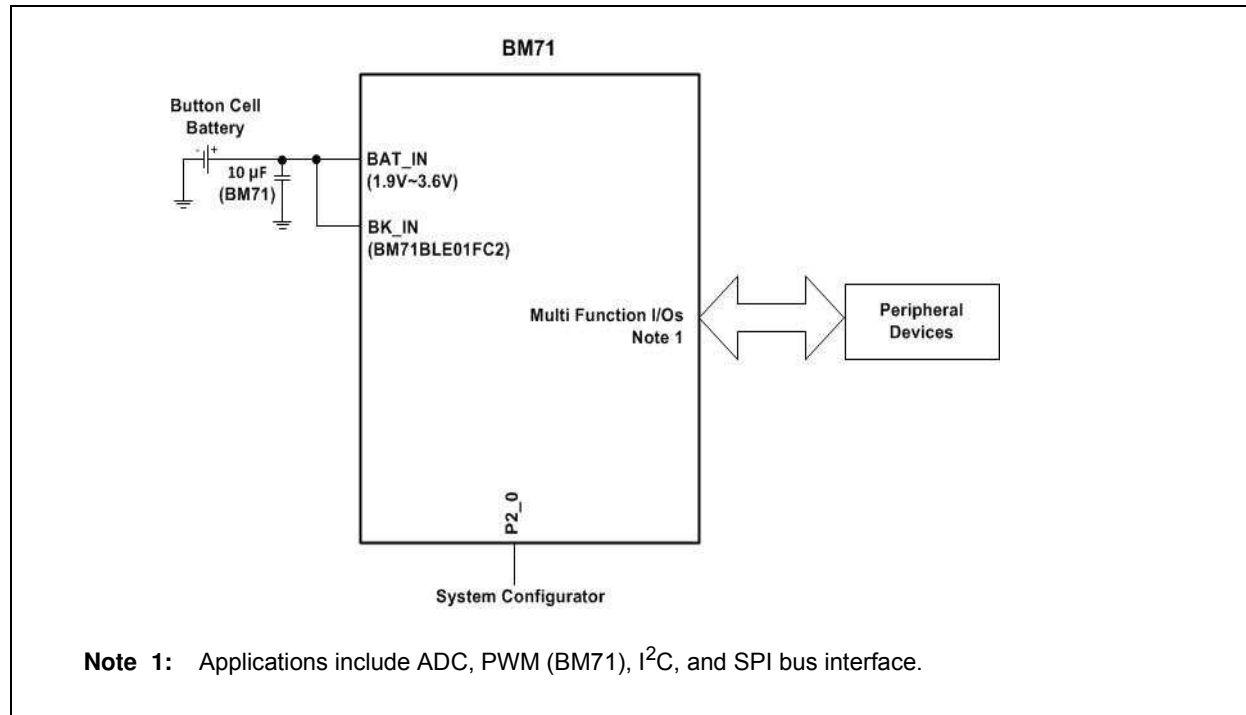

2.5 Power-Drop Protection

To prevent the BM70/71 from disruptions, when the voltage drops to less than 1.9V, an 'Open Drain' Reset chip with a delay time of ≤ 10 ms that triggers Reset at 1.8V output voltage is recommended. [Figure 2-15](#) illustrates the Reset circuit block diagram.

FIGURE 2-15: RESET CIRCUIT BLOCK DIAGRAM

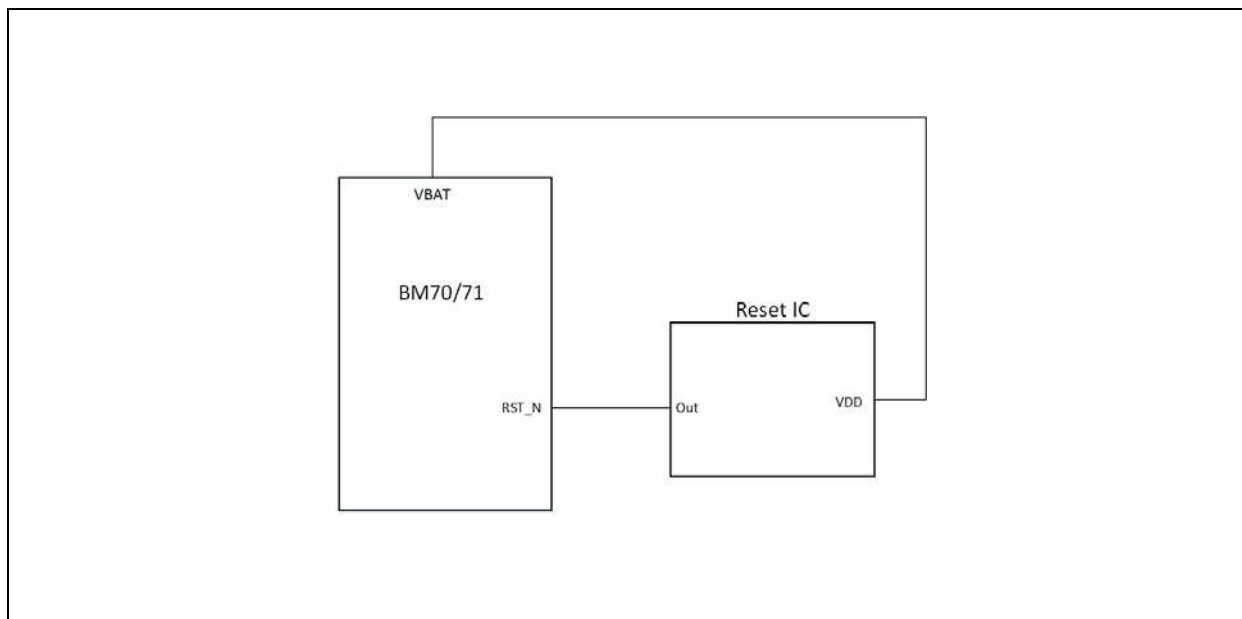

BM70/71

NOTES:

3.0 MODULE CONFIGURATION

The BM70/71 features and services can be configured using the Windows UI Configuration tool. For additional information, refer to the “*Windows UI Configuration tool User’s Guide*”.

3.1 UART Interface

The BM70/71 UART pins, TXD and RXD, are connected to the UART pins of the host MCU. It is recommended to use hardware flow control pins, RTS and CTS. By default, the BM70/71 hardware flow control is disabled, and users must configure the pin to enable the same. The UART baud rate is configurable.

3.2 Control and Indication I/O Pins

The I/O pins on the BM70/71 are configurable as either control or indication signal. The control signals are input to the BM70/71 and the indication signals are output from the BM70/71. [Table 3-1](#) provides configurable I/O pin assignment details to control and indication signals of BM70 BLEDK3 (BLE Development Kit V3). For different BM70/71 applications, the I/O pin assignment is different. For additional information related to I/O pin assignment, refer to the “*Windows UI Configuration tool User Guide*” of each BM70/71 application firmware.

TABLE 3-1: CONFIGURATION AND INDICATION I/O ASSIGNMENTS FOR BM70 BLEDK3 APPLICATIONS

PINS	N/C	LOW_BATTERY_IND	RSSI_IND	LINK_DROP	UART_RX_IND	PAIRING_KEY	RF_ACTIVE_IND	BLEDK_STATUS1_IND (*Note)	BLEDK_STATUS2_IND (*Note)
P1_0									Default
P3_1			Default						
P3_2				Default					
P3_3					Default				
P3_4						Default			
P0_7		Default							
P1_1								Default	
P2_2	Default								
P2_4	Default								
P3_5	Default								

Note: For additional information on the BLEDK application status, refer to the “*BLEDK3 Release Notes*.”

BM70/71

Table 3-2 provides pin assignment details for the BM70 BLEDK3 application.

TABLE 3-2: PIN ASSIGNMENT FOR BM70 BLEDK3 APPLICATION

Pin Name	Pin Assignment
P3_6	UART_RTS
P0_0	UART_CTS
P2_7	TX_IND
P1_2	I ² C_SCL
P1_3	I ² C_SDA
P0_2	LED0

3.3 Reset (RST_N)

The Reset input pin (RST_N) is used to Reset the BM70/71 with an active-low pulse with a minimum pulse width of 63 ns.

3.4 System Configuration

Table 3-3 provides the system configuration settings of the P2_0 pin that places the BM70/71 into operation modes. The P2_0 pin has an internal pull-up.

TABLE 3-3: SYSTEM CONFIGURATION SETTINGS

P2_0	Operational Mode
High	Application mode
Low	Test mode (Write UI/Flash: Firmware Programming)

4.0 ANTENNA

Table 4-1 provides the antenna characteristics of the BM70BLES1FC2 module.

4.1 Antenna Characteristics

4.1.1 BM70BLES1FC2 CERAMIC CHIP ANTENNA

The BM70BLES1FC2 module contains an inbuilt ceramic chip antenna. The antenna performance of the BM70BLES1FC2 is shown in Figure 4-1.

FIGURE 4-1: BM70BLES1FC2 ANTENNA RADIATION PATTERN

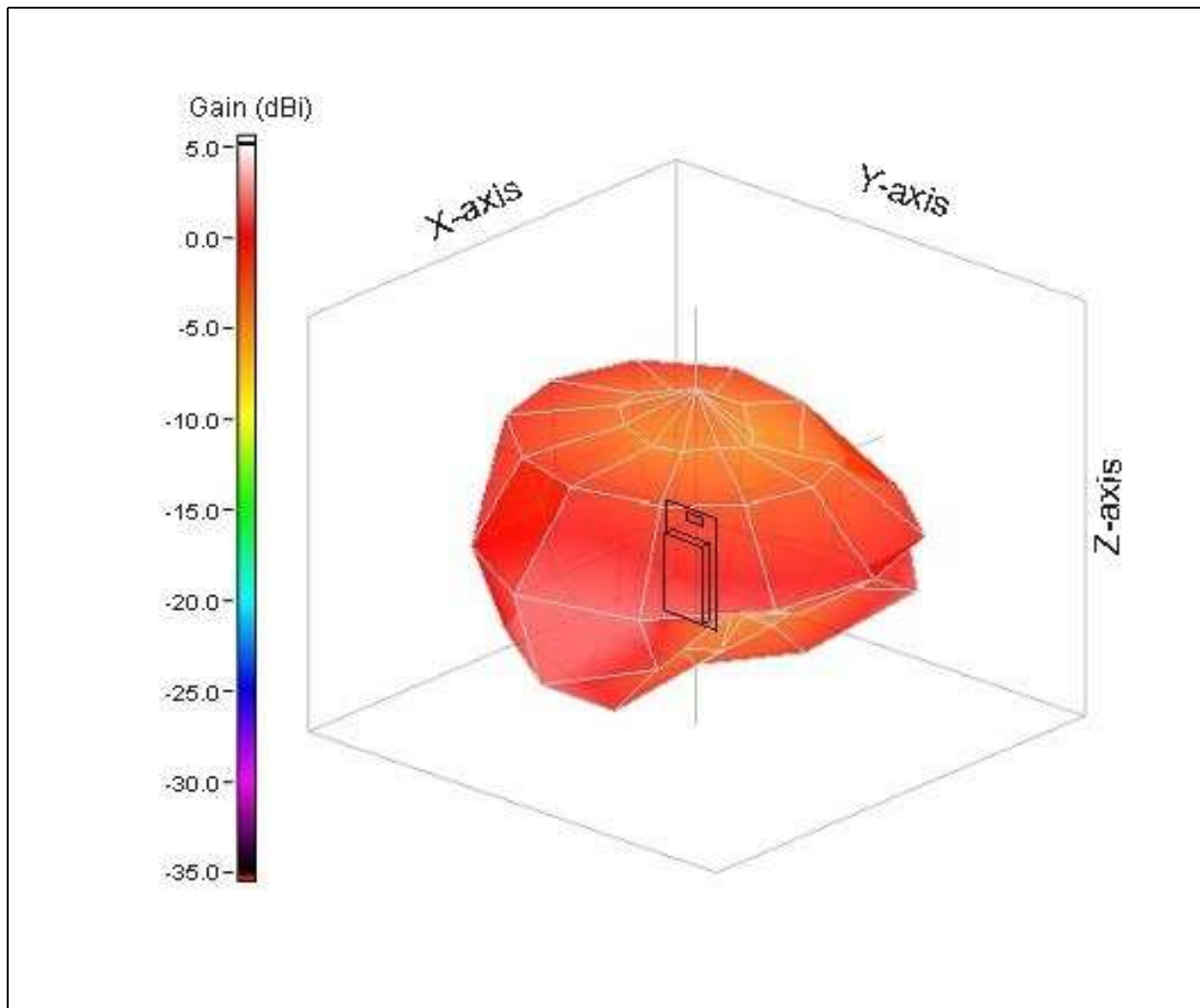

TABLE 4-1: BM70BLES1FC2 ANTENNA CHARACTERISTICS

Parameter	Values
Frequency	2450 MHz
Peak Gain	1.63 dBi
Efficiency	71.55%

BM70/71

4.1.2 BM71BLES1FC2 CERAMIC CHIP ANTENNA

Table 4-2 provides the BM71BLES1FC2 antenna characteristics.

The BM71BLES1FC2 module contains an inbuilt ceramic chip antenna. The antenna performance of the BM71BLES1FC2 module is shown in Figure 4-2.

FIGURE 4-2: BM71BLES1FC2 ANTENNA RADIATION PATTERN

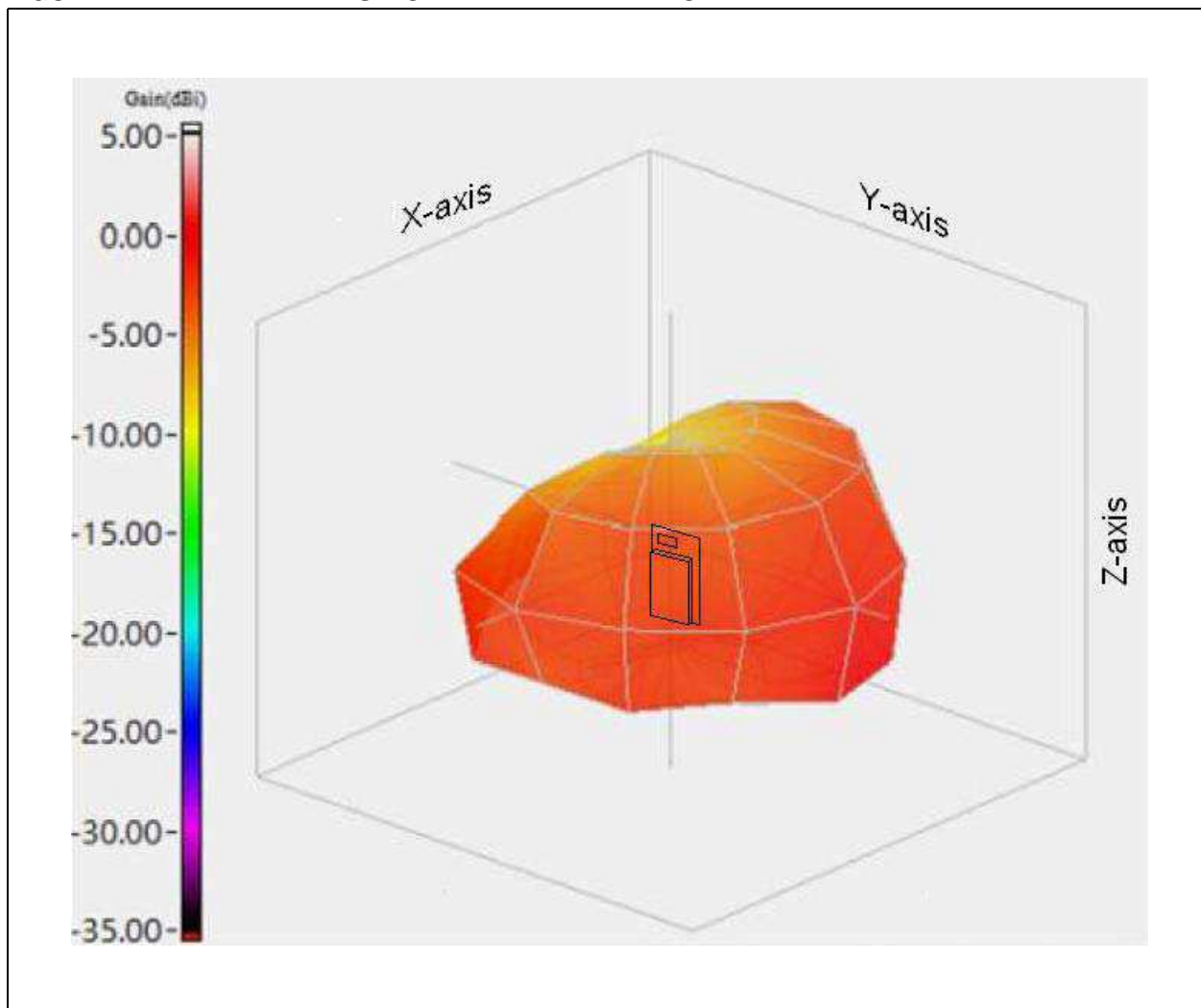

TABLE 4-2: BM71BLES1FC2 ANTENNA CHARACTERISTICS

Parameter	Values
Frequency	2442 MHz
Peak Gain	0.1 dBi
Efficiency	42.7%

4.2 Antenna Placement

For a Bluetooth wireless product, antenna placement affects the whole system performance. The antenna needs free space to transmit RF signals and cannot be

surrounded by the GND plane. [Figure 4-3](#) and [Figure 4-4](#) illustrate a typical example of the antenna placement on the main application board with ground plane.

FIGURE 4-3: BM70BLES1FC2 ANTENNA PLACEMENT RECOMMENDATION

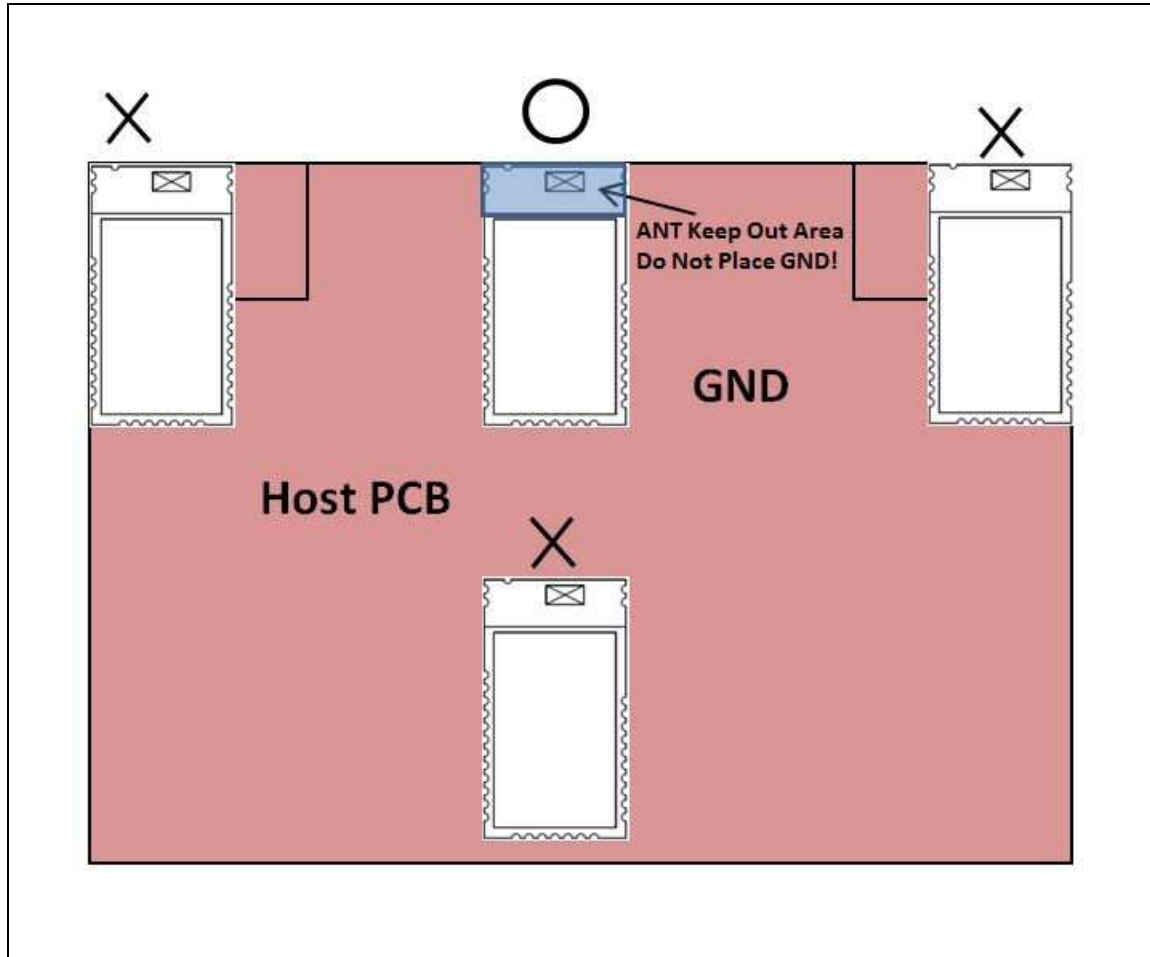

BM70/71

FIGURE 4-4: BM71BLES1FC2 ANTENNA PLACEMENT RECOMMENDATION

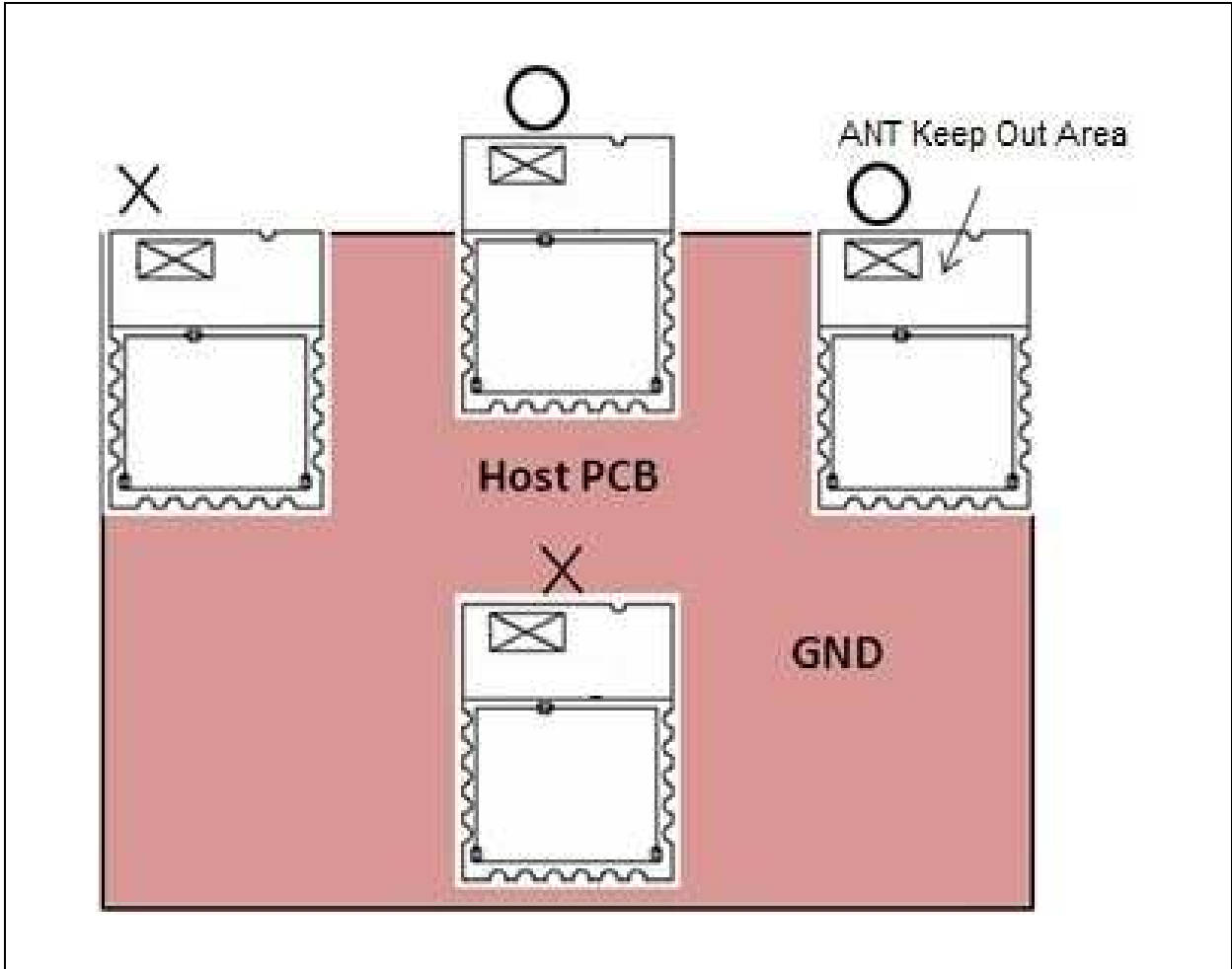

4.3 Host PCB Mounting Suggestion

4.3.1 BM70BLES1FC2 HOST PCB MOUNTING

Figure 4-5 illustrates the host PCB mounting suggestions for the BM70BLES1FC2 module, and it shows minimum ground plane area to the left and right of the module for best antenna performance.

While designing the host PCB, the area under the antenna should not contain any top, inner, or bottom copper layer. A low-impedance ground plane ensures the best radio performance (best range, low noise). The ground plane can be extended beyond the minimum recommended as required for the host PCB EMC noise reduction. For best range performance, keep all external metal away by minimum 30 mm from the ceramic chip antenna.

FIGURE 4-5: BM70BLES1FC2 HOST PCB MOUNTING SUGGESTION

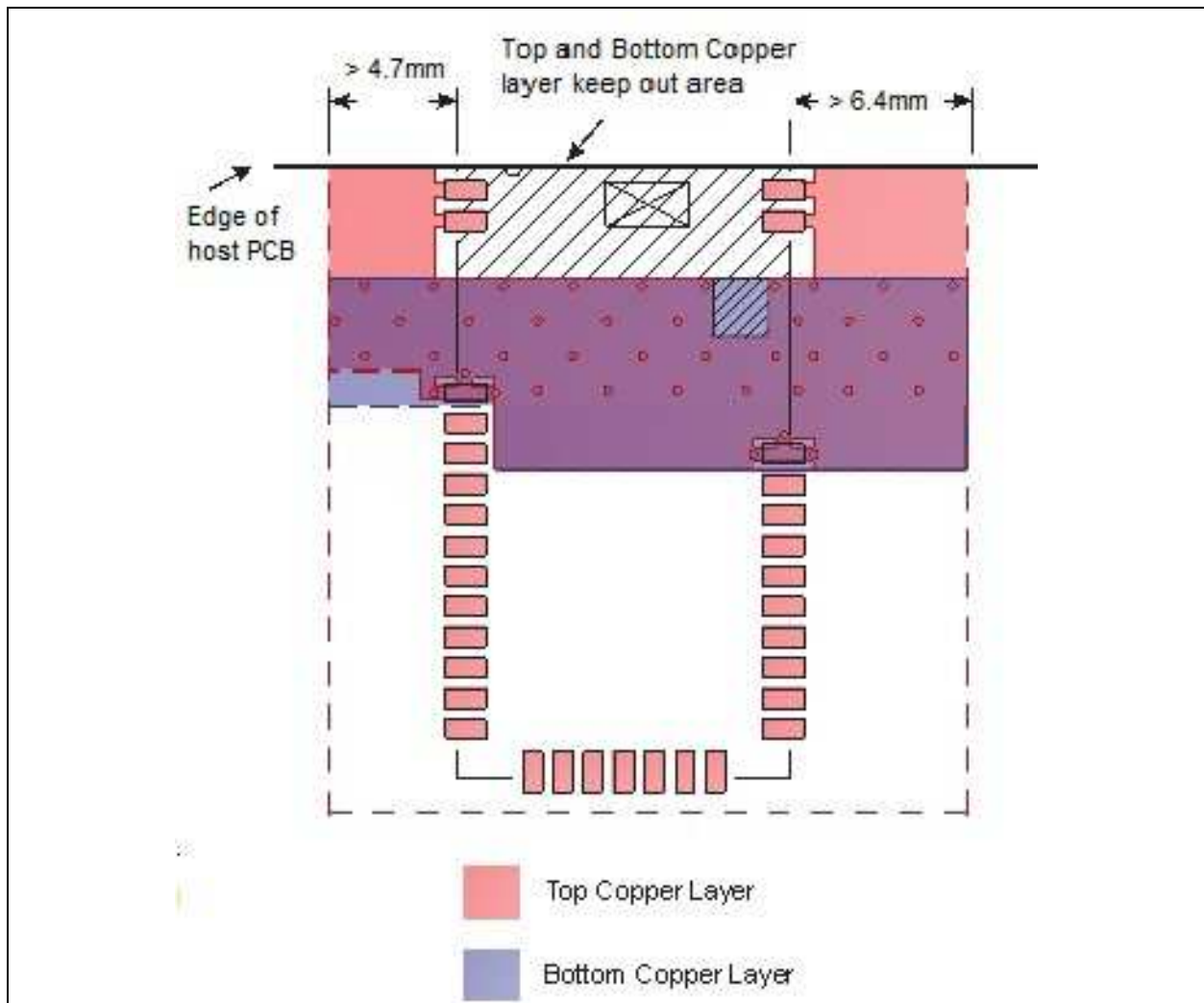

BM70/71

4.3.2 BM70BLE01FC2 HOST PCB MOUNTING

Figure 4-6 illustrates the mounting suggestions for the BM70BLE01FC2 module and it also shows a connection to UFL connector. A low-impedance ground plane will ensure the best radio performance (best range, low noise).

The pin_30 (BT_RF) is connected to an external antenna connector, a PCB trace antenna, or a component (ceramic chip) antenna through a host PCB

50 Ohm micro-strip trace. The micro-strip trace can be extended to include passive parts for antenna attenuation padding, impedance matching, or to provide test points. It is recommended that the micro-strip trace be as short as possible for minimum loss and best impedance matching. If the micro-strip trace is longer, it should be a 50 Ohm controlled impedance.

FIGURE 4-6: BM70BLE01FC2 HOST PCB MOUNTING SUGGESTIONS

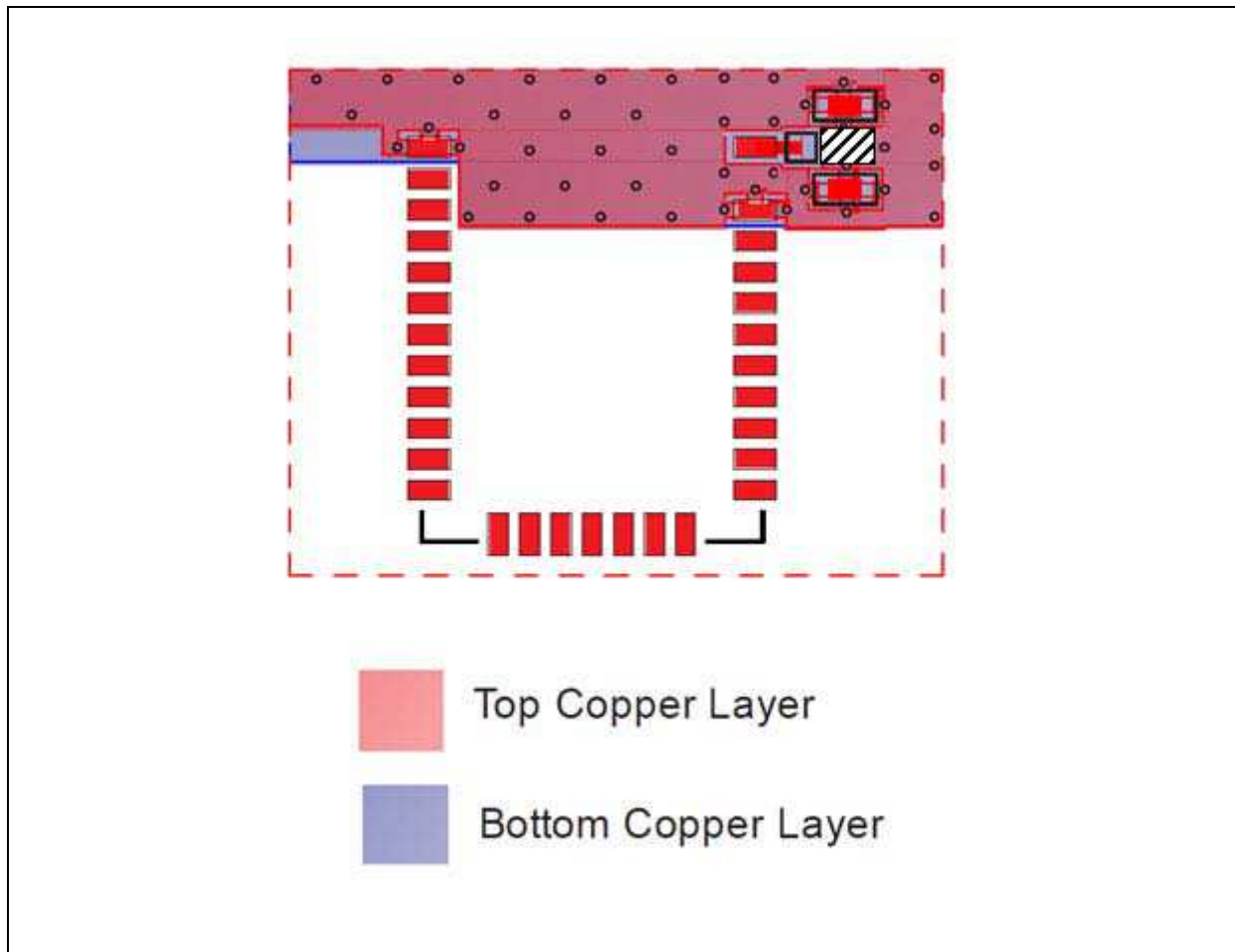

4.3.3 BM71BLES1FC2 HOST PCB MOUNTING

Figure 4-7 illustrates the mounting suggestions for the BM71BLES1FC2 module. It also shows the area around the antenna required for the best antenna performance.

The area under the antenna should not contain any top, inner, or bottom copper layer when designing the host PCB. A low-impedance ground plane ensures the best radio performance (best range, low noise). The ground plane can be extended beyond the minimum recommended as required for the host PCB EMC noise reduction. For best range performance, keep all external metal away by minimum 30 mm from the ceramic chip antenna.

FIGURE 4-7: BM71BLES1FC2 HOST MOUNTING SUGGESTION

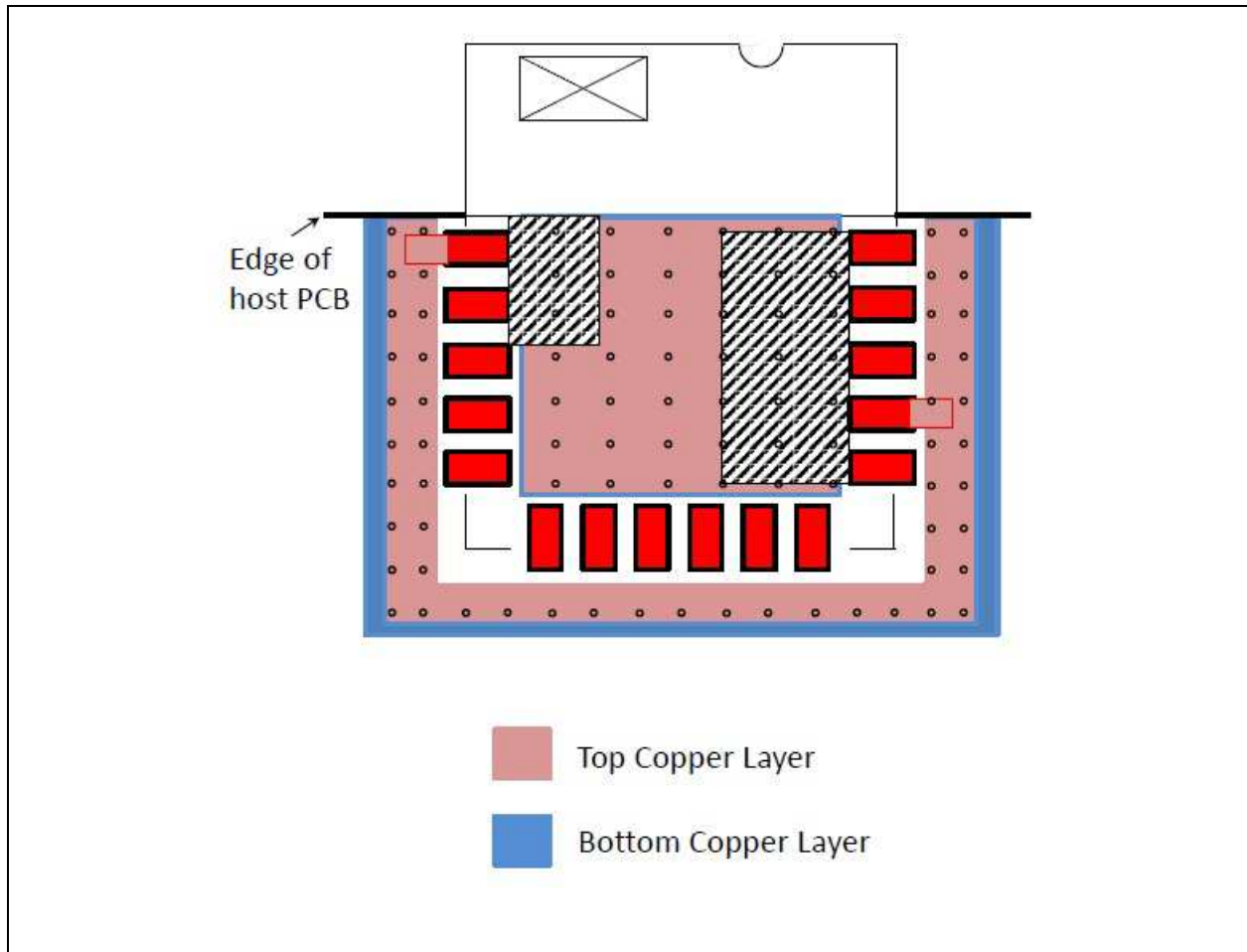

BM70/71

4.3.4 BM71BLE01FC2 HOST PCB MOUNTING

Figure 4-8 illustrates the mounting suggestions for the BM71BLE01FC2 module. It also shows a connection to the UFL connector. A low-impedance ground plane will ensure the best radio performance (best range, low noise).

The pin_1 (BT_RF) is connected to an external antenna connector, a PCB trace antenna, or a component (ceramic chip) antenna through a host PCB 50 Ohm micro-strip trace. The micro-strip trace can be extended to include passive parts for antenna attenuation padding, impedance matching, or to provide test posts. It is recommended that the micro-strip trace be as short as possible for minimum loss and best impedance matching. If the micro-strip trace is longer, it should be 50 Ohm controlled impedance.

FIGURE 4-8: BM71BLE01FC2 HOST PCB MOUNTING SUGGESTION

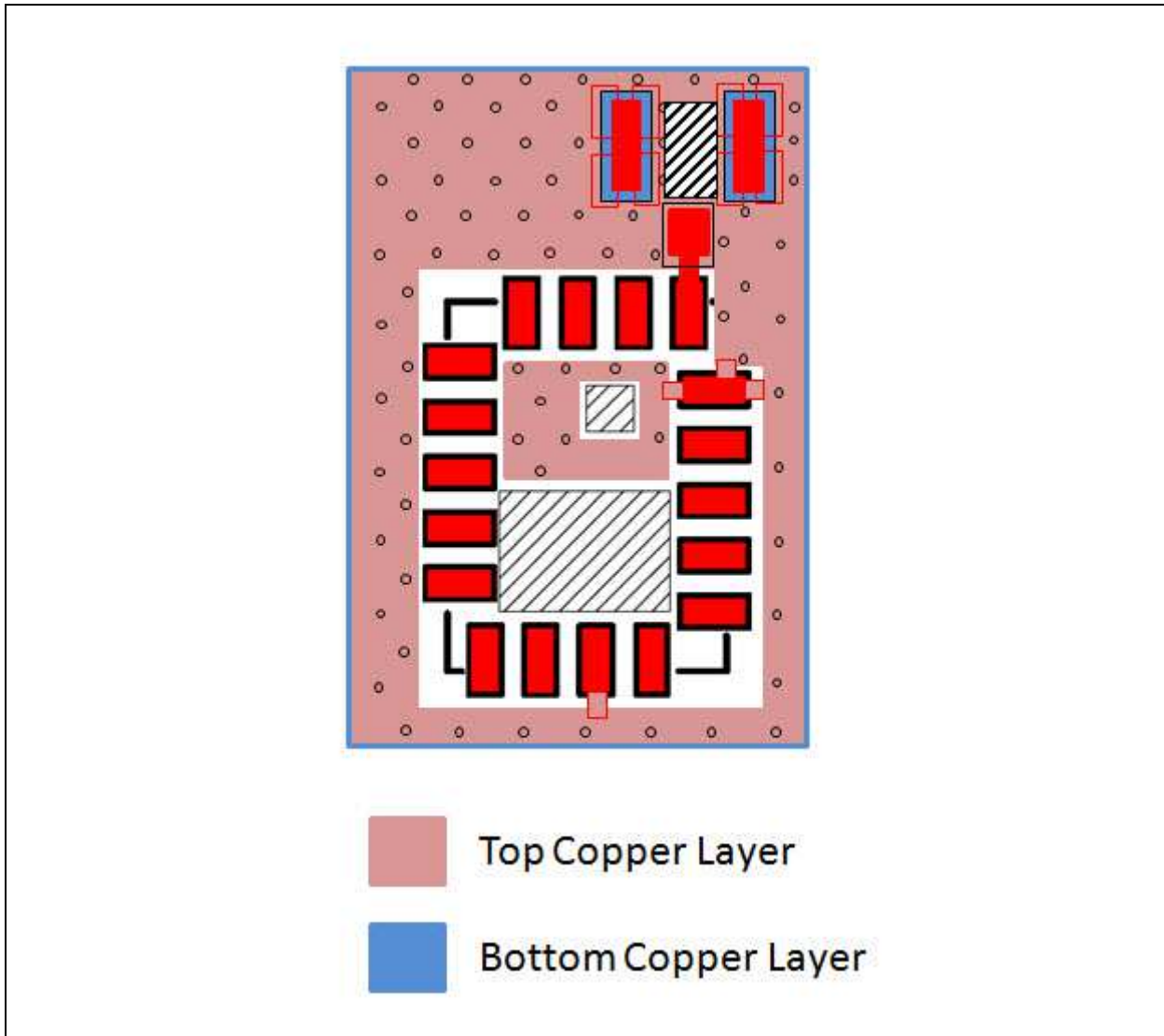

5.0 ELECTRICAL CHARACTERISTICS

This section provides an overview of the BM70/71 modules electrical characteristics. Additional information will be provided in future revisions of this document.

Absolute maximum ratings for the BM70/71 devices are listed here. Exposure to the maximum rating conditions for extended periods may affect device reliability. Functional operation of the device at these or any other conditions, above the parameters indicated in the operation listings of this specification, is not implied.

5.1 Absolute Maximum Ratings

(See Note 1)

Ambient temperature under bias	-20°C to +70°C
Storage temperature	-40°C to +125°C
Voltage on VDD with respect to Vss	-0.3V to +3.6V
Voltage of any digital pin	-0.3V to VDD + 0.3 ≤ 3.9
Maximum output current sunk by any I/O pin.....	12 mA
Maximum output current sourced by any I/O pin.....	12 mA

Note 1: Stresses above those listed under “**Absolute Maximum Ratings**” may cause permanent damage to the device. This is a stress rating only and functional operation of the device at those or any other conditions, above those indicated in the operation listings of this specification, is not implied. Exposure to maximum rating conditions for extended periods may affect device reliability.

BM70/71

TABLE 5-1: RECOMMENDED OPERATING CONDITIONS

Symbol	Min.	Typ.	Max.
Ambient operating temperature range	-20°C	+25°C	+70°C
PMU			
VDD (VBAT, BK_IN), AVDD	1.9V	3.0V	3.6V
RST_N	1.9V	3.0V	3.6V
Other I/Os	1.9V	—	3.6V
GPIO			
V _{IH} (Input High Voltage)	0.7 VDD	—	VDD
V _{IL} (Input Low Voltage)	VSS	—	0.3 VDD
V _{OH} (Output High Voltage) (High drive, 12 mA)	0.8 VDD	—	VDD
V _{OL} (Output Low Voltage) (High drive, 12 mA)	VSS	—	0.2 VDD
Pull-up Resistance	34K	48K	74K
Pull-down Resistance	29K	47K	86K
Supply Current			
TX mode peak current at VDD=3V, TX=0dBm, Buck mode	—	—	13 mA
RX mode peak current at VDD=3V, Buck mode	—	—	13 mA
Link static current	—	60 μA	—
Standby current	1.9 μA	—	2.9 μA
Power-Saving	1 μA	—	1.7 μA
Analog to Digital Converter (ADC)			
Full scale (BAT_IN)	0V	3.0V	3.6V
Full scale (AD0~AD15)	0V	—	3.6V
Conversion time (ENOB 8-bit)	—	131 μS	—
Conversion time (ENOB 10-bit)	—	387 μS	—
Operating current	—	—	500 μA
DNL	-1.12 LSB	—	+1.12 LSB
INL	-4.38 LSB	—	+4.38 LSB
Precise Temperature Sensor (PTS)			
Detect range	-20°C	—	+70°C
Digital Output	1387	—	2448
Resolution	—	12-bit/°C	—
Accuracy	-3°C	—	+3°C
Conversion time (ENOB 10-bit)	—	12.35 mS	—
Operating current	—	—	200 μA

5.2 Current Consumption Details

5.2.1 Tx/Rx CURRENT CONSUMPTION DETAILS

Figure 5-1 and Figure 5-2 illustrate the Tx/Rx peak and average current consumption of an advertising event in the BLEDK3 beacon mode application.

The peak current consumption of the VBAT input is 12 mA and the average current consumption is around 0.23 mA. In this example the advertising interval is 100 mS. Current consumption is measured at 3.3V VBAT input.

FIGURE 5-1: TX/RX PEAK CURRENT CONSUMPTION OF ADVERTISING EVENT IN BLEDK3 BEACON MODE

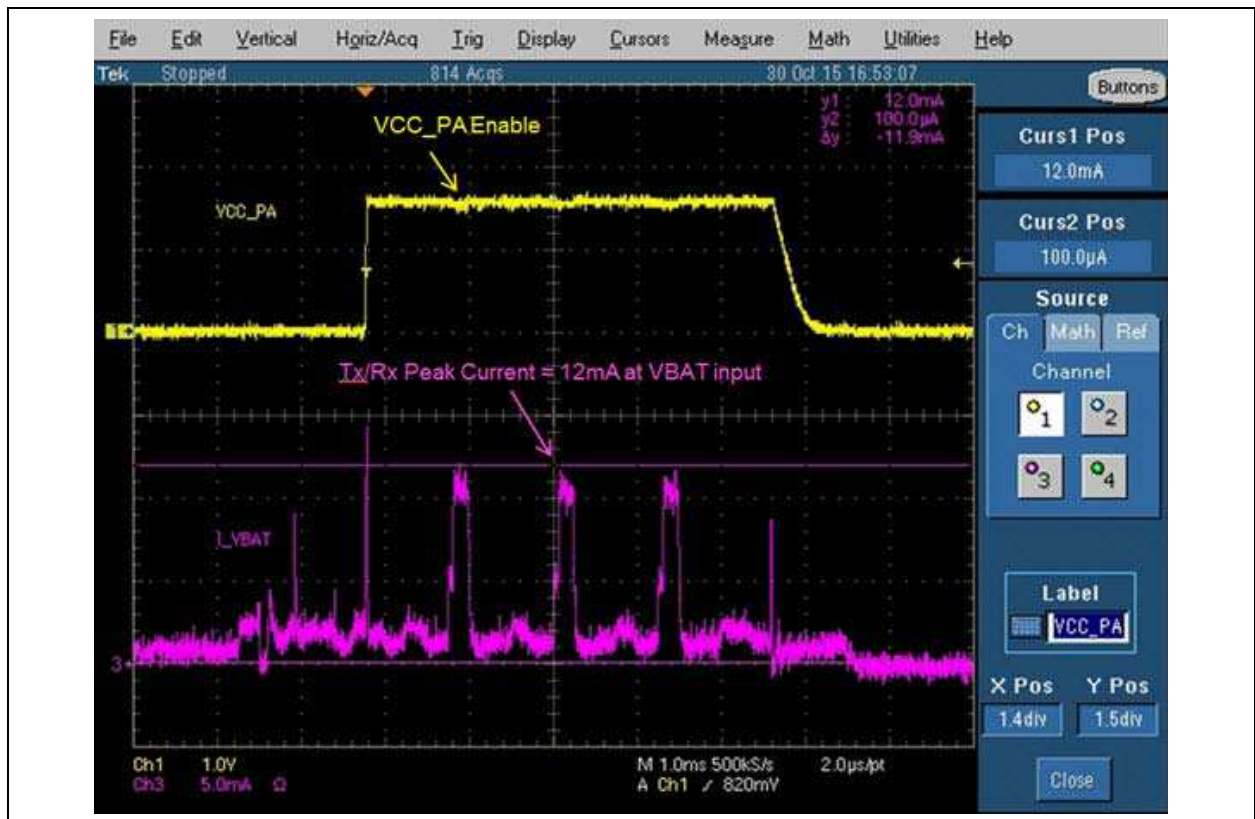
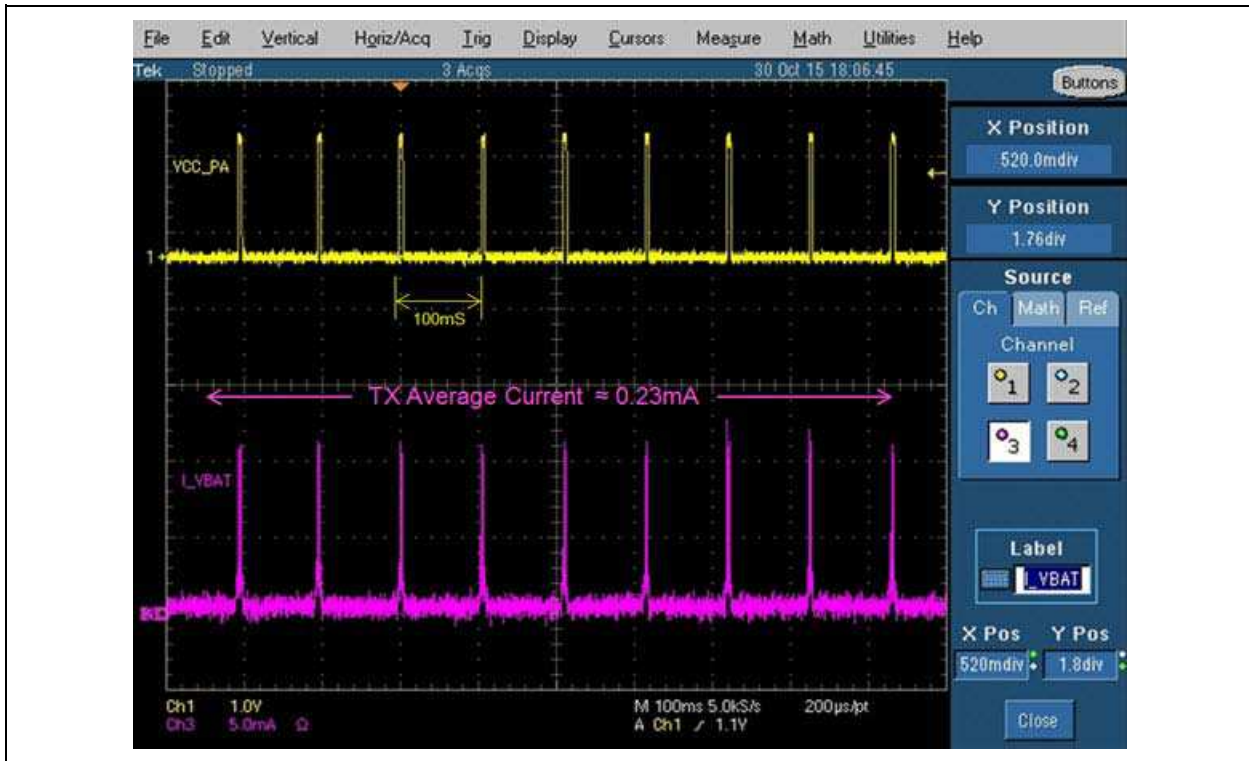

FIGURE 5-2: TX/RX AVERAGE CURRENT CONSUMPTION OF ADVERTISING EVENT IN BLEDK3 BEACON MODE



For additional information on the current consumption measurements, test conditions, and test environment setups in the BLEDK3 application, refer to the “IS187x_BM7x BLEDK3 Application Note”. This Appli-

cation Note covers the detailed information about status of BLEDK3 application. [Table 5-2](#) provides the status and description of the BLEDK3 application.

TABLE 5-2: STATUS OF BLEDK3 APPLICATION EXAMPLE

Status	Description
Shutdown Mode	BLEDK3 is shutdown.
Standby Mode	BLEDK3 sends advertising packets and wait for connection. BLEDK3 is discoverable and connectible.
BLE Connected Mode	BLE link is established and CCCD of ISSC_Transparent_TX characteristic is disabled (see Note 1).
Transparent Service Enabled Mode	BLE link is established and CCCD of ISSC_Transparent_TX characteristic is enabled (see Note 1).

Note 1: Client Characteristic Configuration (CCCD) is the Generic Attribute Profile (GATT) service characteristics.

TABLE 5-3: BM70BLE01FC2 APPLICATION MODE CURRENT CONSUMPTION^(1,2,3,4,5,6)

Test Mode/Test Condition		Average Current Consumption	Note
Standby Mode	Advertising Interval: 100 ms	0.23 mA	UI: Set as beacon
	Advertising Interval: 500 ms	0.077 mA	UI: Set as beacon
BLE Connected Mode (no data exchange)	Connection Interval: 500 ms Slave Latency: 2	0.08 mA	Measured when transparent page is open on the BLEDK3 Application.
Transparent Service Enable Mode Tx data	Connection Interval: 18.75 ms Slave Latency: 0	3.87 mA	Maximum Tx data throughput setting tested file size: 100 KB Tx data throughput: 9.863 KB/s
Transparent Service Enable Mode Tx data	Connection Interval: 40 ms Slave Latency: 0	2.77 mA	Tested File: 100 KB Tx data throughput: 4.676 KB/s
Transparent Service Enable Mode Rx data	Connection Interval: 18.75 ms Slave Latency: 0	3.06 mA (Write with response) 3.9 mA (Write with reliable Burst Transmit)	Maximum Rx data throughput setting tested file size: 100 KB Throughput: 4.956 KB/s (Write with response) 9.382 KB/s (Write with reliable Burst Transmit)
Transparent Service Enable Mode Tx data	Connection Interval: 40 ms Slave Latency: 0	2.14 mA (Write with response) 3.03 mA (Write with reliable Burst Transmit)	Tested File size: 100 KB Throughput: 2.494 KB/s (Write with response) 5.056 KB/s (Write with reliable Burst Transmit)
Shut Down mode		1.44 μ A	

Note 1: Test condition: VBAT=3.3V, LED set off and measured in VBAT input.

2: Flash code version: BLEDK3 v1.03, UI version: IS187x_102_BLEDK3_UIv100.123.

3: Test phone: iPhone[®] 6+ with iOS 9.02.

4: Test application version: BLEDK3 V1.2.

5: UI set flow control and RX_IND.

6: For information on how to measure the current, refer to the "IS187x_BM7x BLEDK3 Application Note".

BM70/71

NOTES:

6.0 PACKAGING INFORMATION

6.1 BM70BLES1FC2

Figure 6-1 illustrates the BM70BLES1FC2 dimensions and Figure 6-2 illustrates the recommended PCB footprint. Ensure that no top copper layer is near the test pin area.

FIGURE 6-1: BM70BLES1FC2 MODULE DIMENSIONS

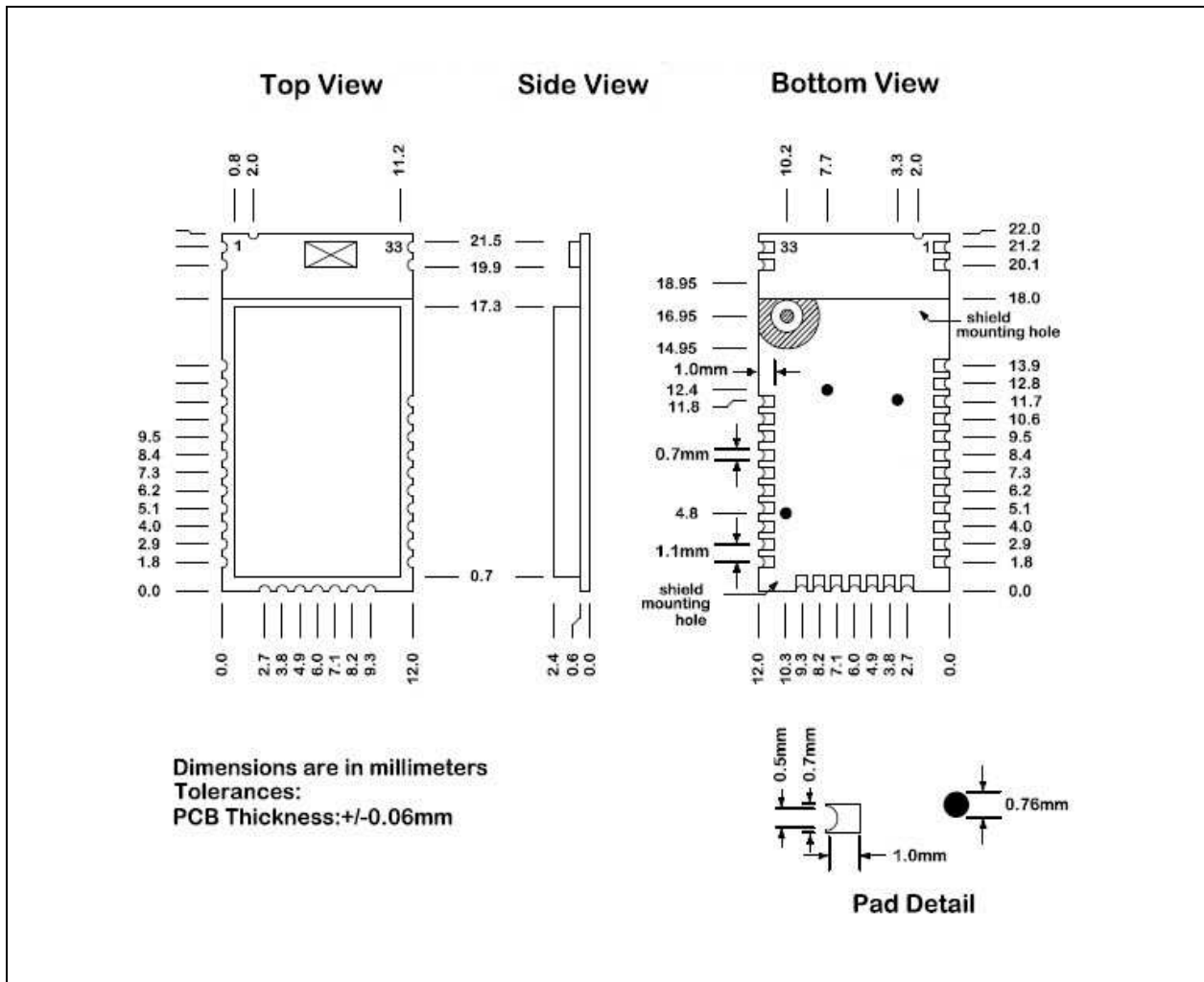

BM70/71

FIGURE 6-2: BM70BLES1FC2 RECOMMENDED PCB FOOTPRINT

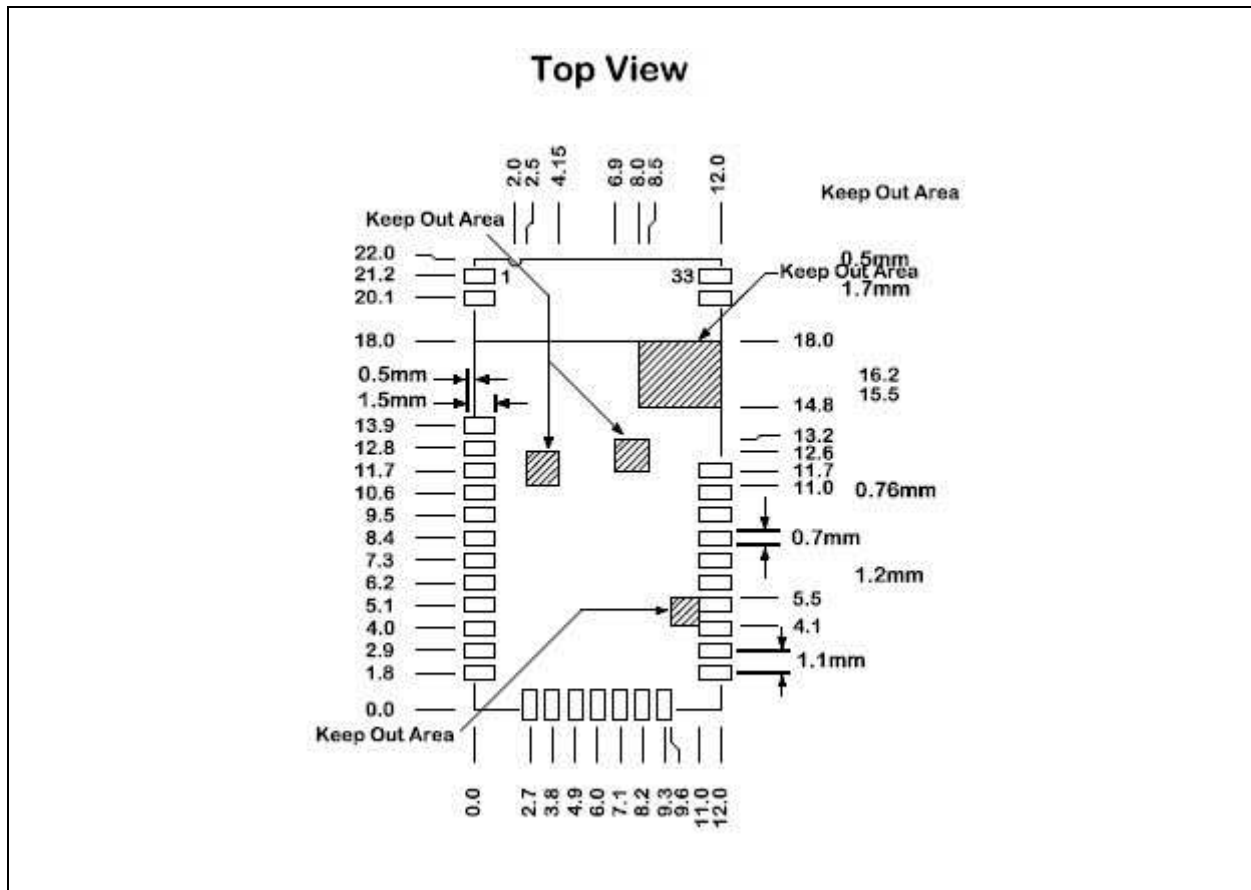

6.2 BM70BLE01FC2

Figure 6-3 illustrates the BM70BLE01FC2 dimensions and Figure 6-4 illustrates the recommended PCB footprint.

FIGURE 6-3: BM70BLE01FC2 MODULE DIMENSIONS

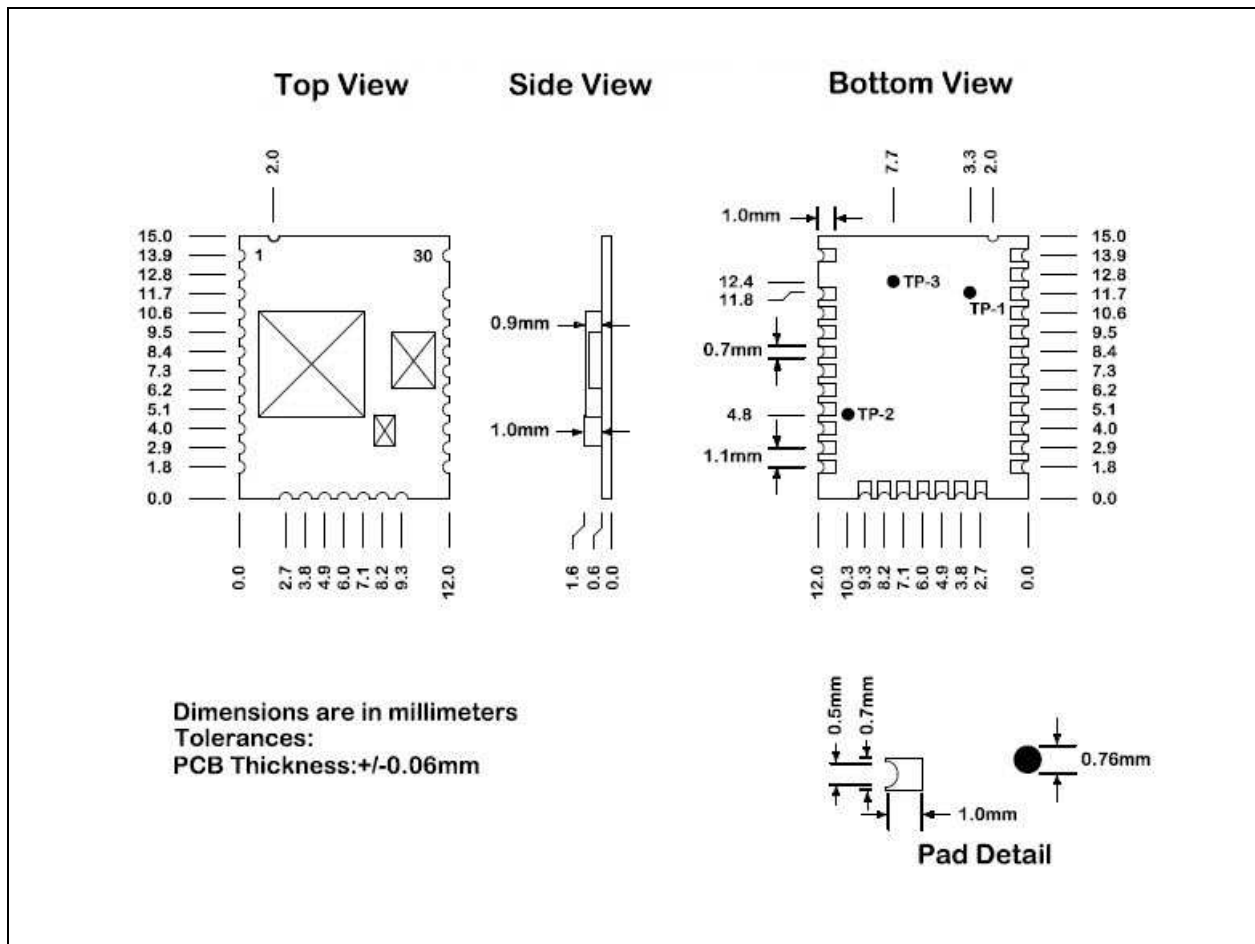

BM70/71

FIGURE 6-4: BM70BLE01FC2 RECOMMENDED PCB FOOT PRINT

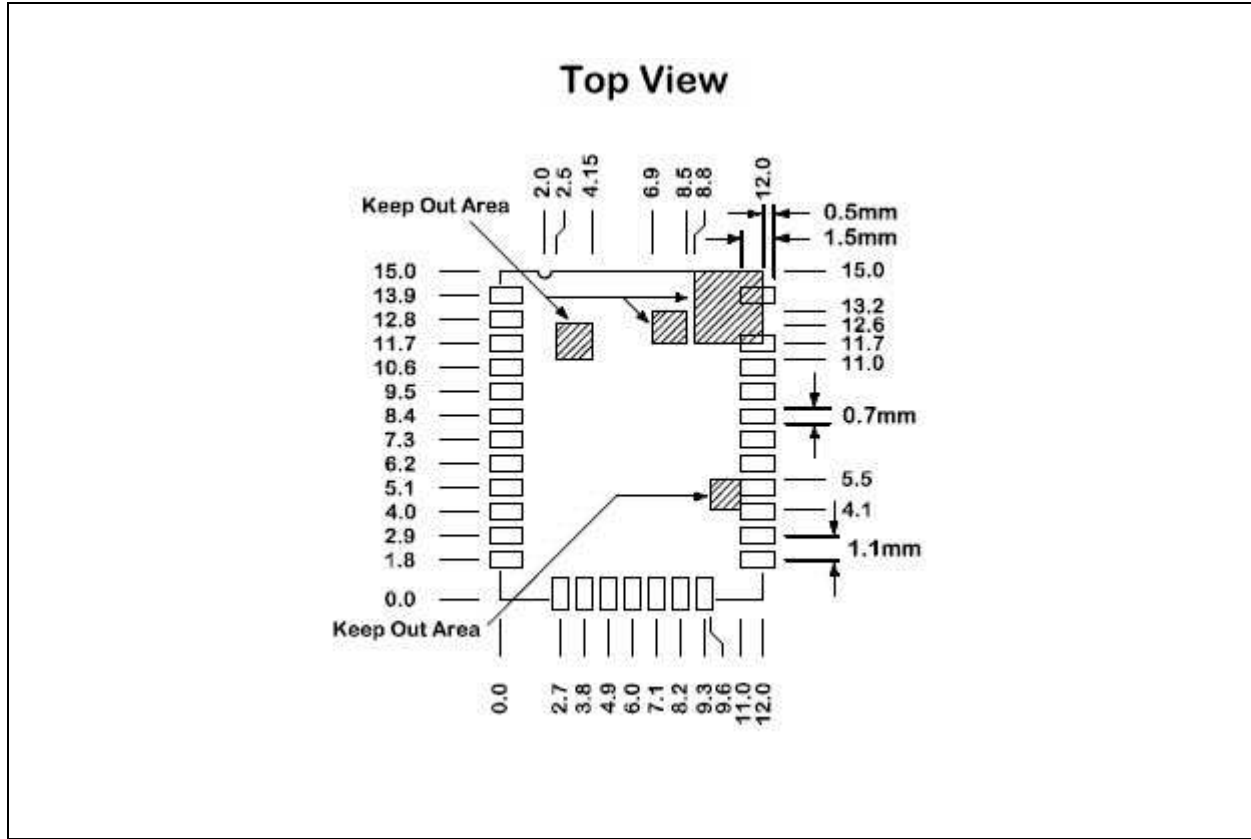

6.3 BM71BLES1FC2

Figure 6-5 illustrates the BM71BLES1FC2 dimensions and Figure 6-6 illustrates the recommended PCB footprint. Ensure that no top copper layer is near the test pin area.

FIGURE 6-5: BM71BLES1FC2 MODULE DIMENSIONS

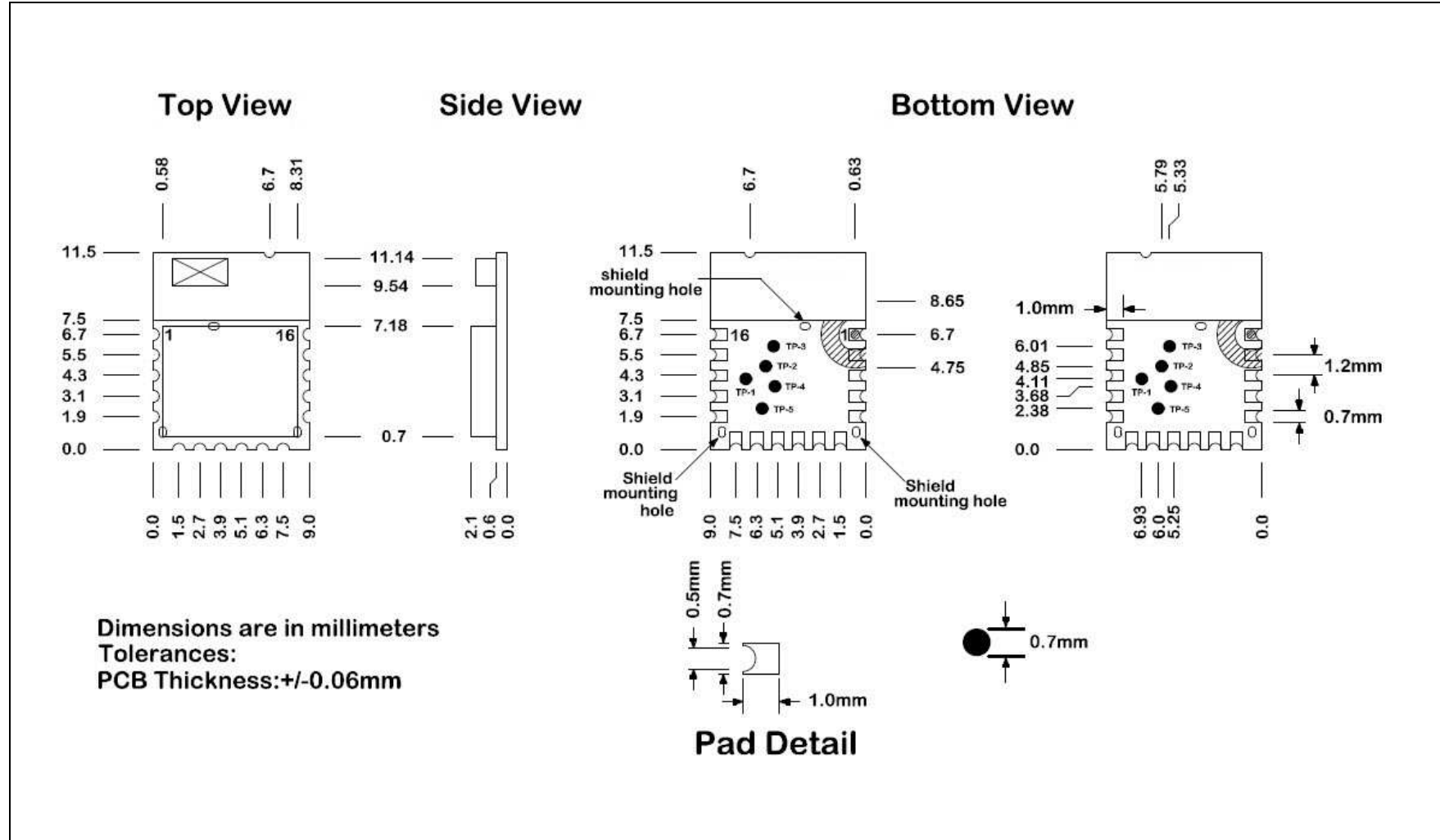

BM70/71

FIGURE 6-6: BM71BLES1FC2 RECOMMENDED PCB FOOTPRINT

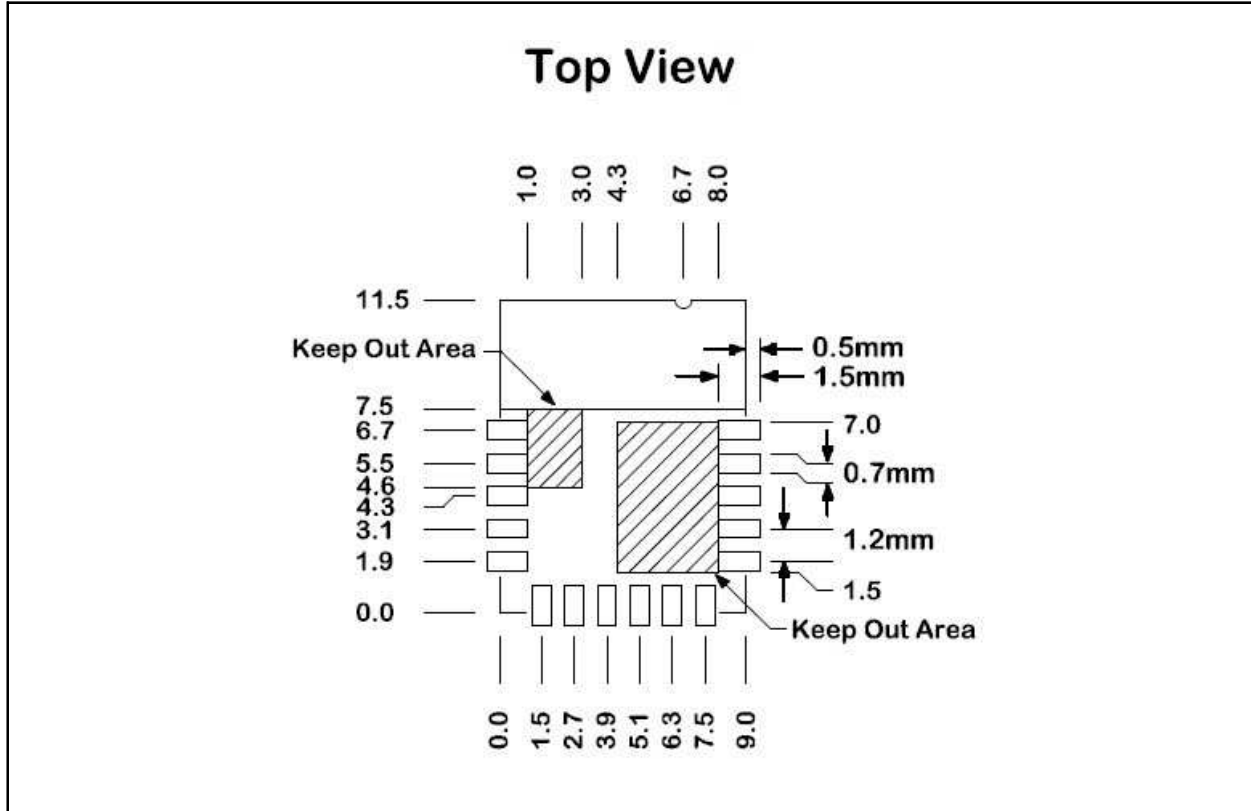

6.4 BM71BLE01FC2

Figure 6-7 illustrates the BM71BLE01FC2 dimensions and Figure 6-8 illustrates the recommended PCB footprint.

FIGURE 6-7: BM71BLE01FC2 MODULE DIMENSIONS

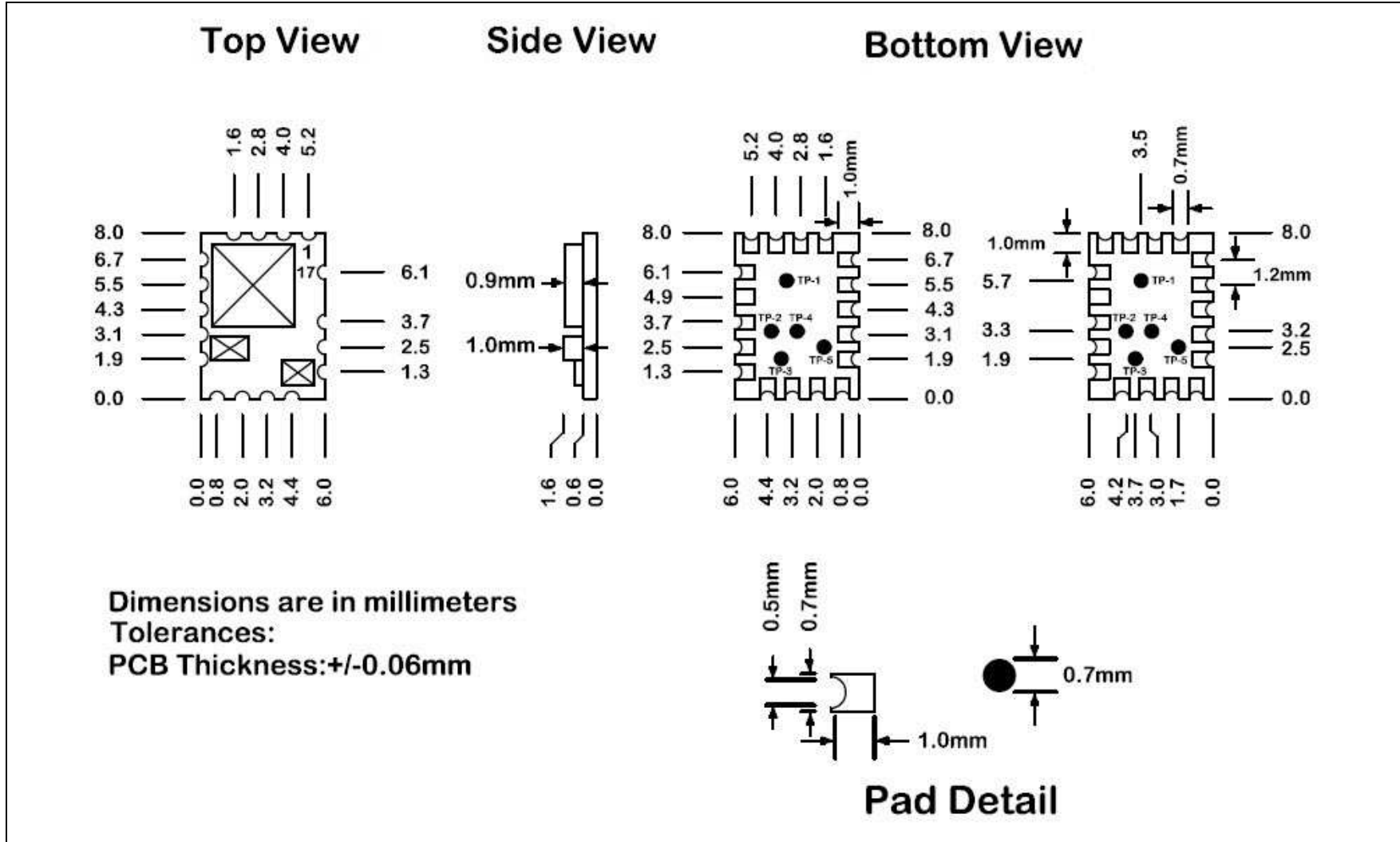

BM70/71

FIGURE 6-8: BM71BLE01FC2 RECOMMENDED PCB FOOTPRINT

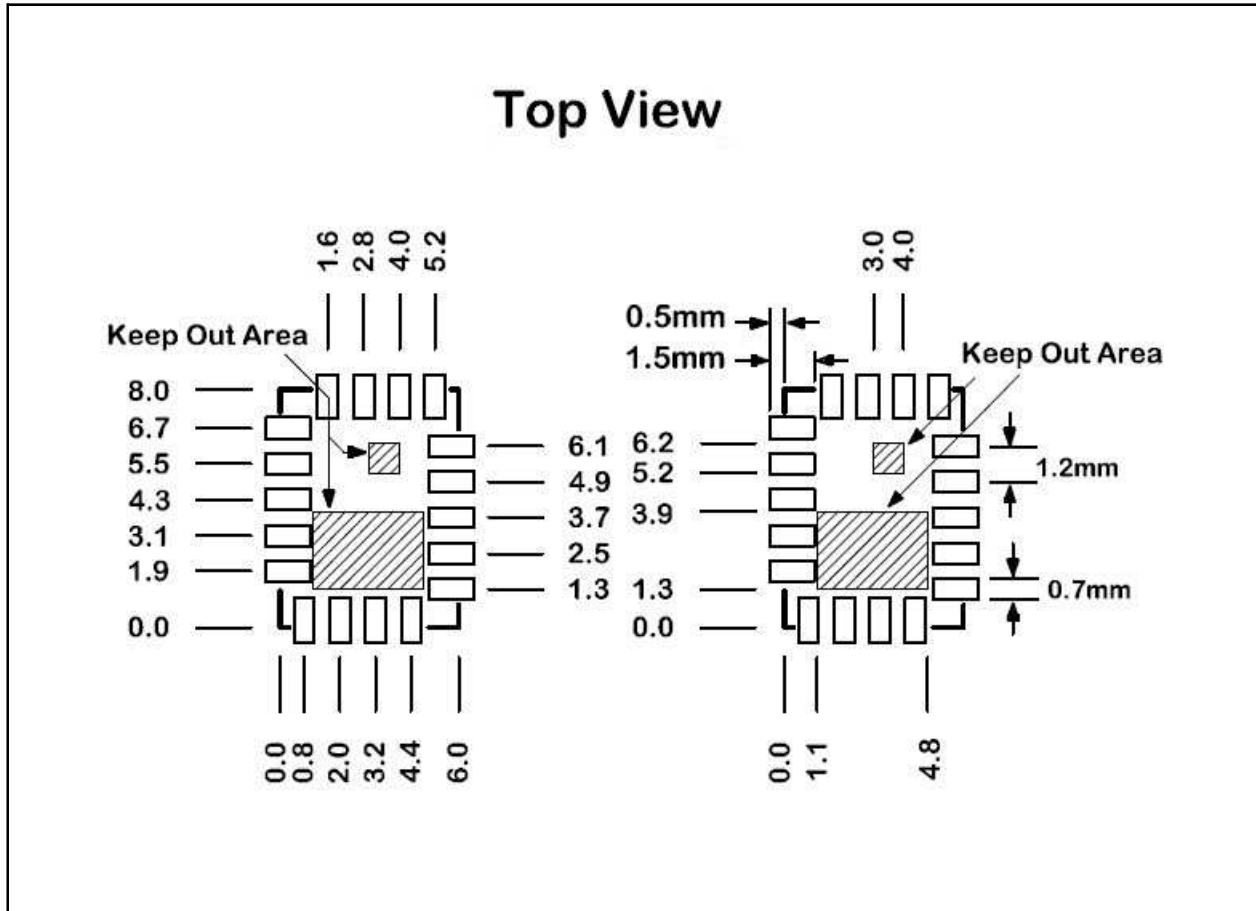

7.0 SOLDERING RECOMMENDATIONS

The BM70/71 should be assembled using a standard lead-free, re-flow profile IPC/JEDEC J-STD-020. The module can be soldered to the host PCB using a standard lead or lead-free solder re-flow profiles, see [Figure 7-1](#).

To avoid any damage to the BM70/71, follow these recommendations:

- Do not exceed the peak temperature (T_P) of $+250^{\circ}\text{C}$
- Use no-clean flux solder paste
- Do not wash as moisture can be trapped under the shield
- Use only one flow. If PCB requires multiple flows, apply the module on the final flow.

For additional information on solder re-flow recommendations, refer to the “*Solder Re-flow Recommendation Application Note*” (DS00233), which is available for download from the Microchip web site at: <http://www.microchip.com>.

FIGURE 7-1: RE-FLOW PROFILE

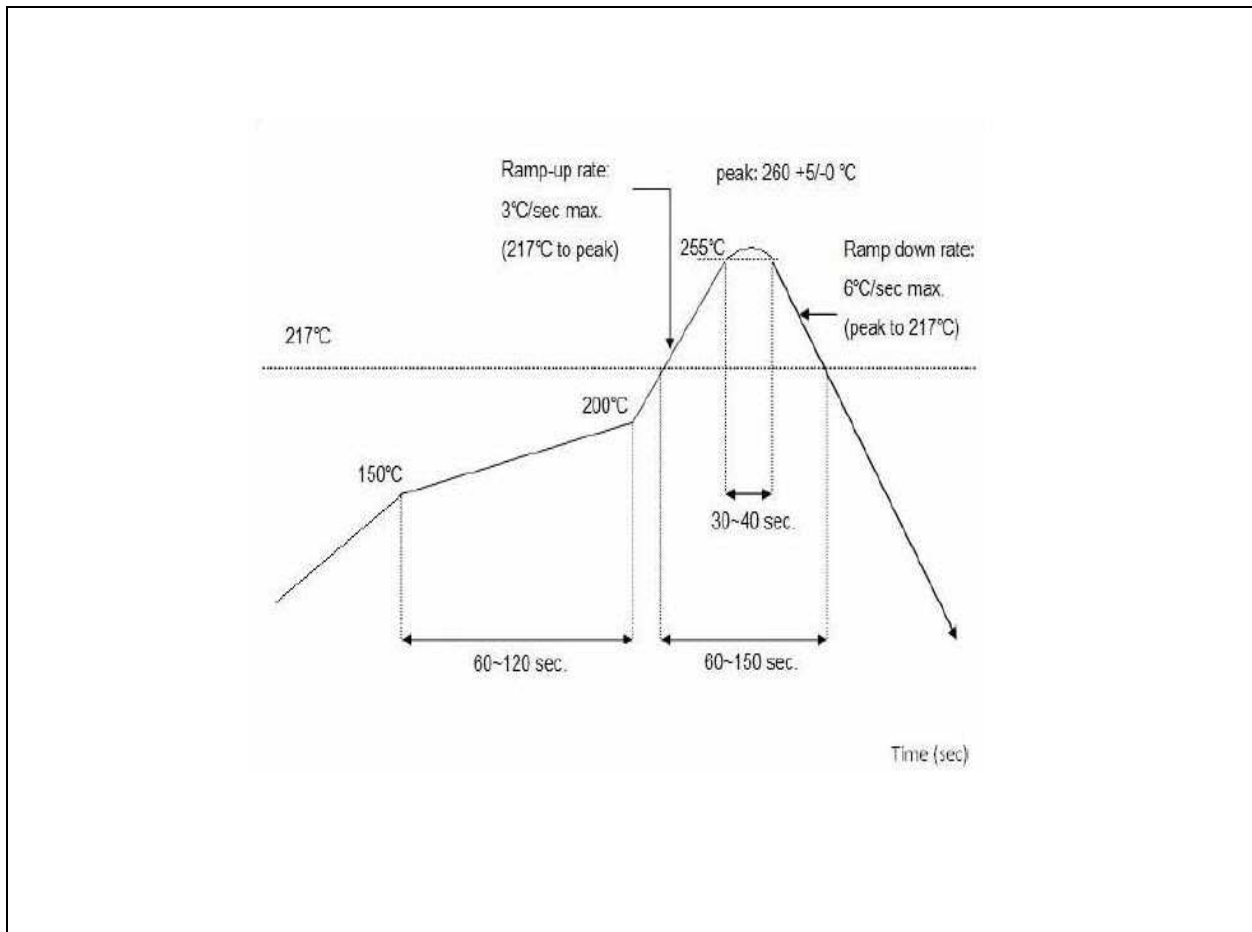

BM70/71

NOTES:

8.0 ORDERING GUIDE

Table 8-1 provides the ordering information for the BM70/71 module.

TABLE 8-1: BM70/71 MODULE VARIANTS

Module	Microchip IC	Description	Antenna	Shield	Pin #	Regulatory Certification	Part Number
BM70	IS1870SF	BT4.2 BLE Module, 12 mm x 15 mm x 1.6 mm	External	No	30	No	BM70BLE01FC2
BM70	IS1870SF	BT4.2 BLE Module, 12 mm x 22 mm x 2.4mm	On board	Yes	33	FCC, IC, CE, MIC, KCC, NCC, SRRC	BM70BLES1FC2
BM71	IS1871SF	BT4.2 BLE Module, 6 mm x 8 mm x 1.6 mm	External	No	17	No	BM71BLE01FC2
BM71	IS1871SF	BT4.2 BLE Module, 9 mm x 11.5 mm x 2.1 mm	On board	Yes	16	FCC, IC, CE, MIC, KCC, NCC	BM71BLES1FC2

Note: The BM70/71 can be purchased by contacting your local Microchip sales office (see last page). For pricing and a list of distributors, visit Microchip web site: <http://www.microchip.com> and for a list of latest certifications visit www.microchip.com/wireless.

BM70/71

NOTES:

APPENDIX A: CERTIFICATION NOTICES

The BM70 module (BM70BLES1FC2) has received the regulatory approval for the following:

- BT SIG/QDID:74246
- United States/FCC ID: A8TBM70ABCDEFGH
- Canada
 - IC ID: 12246A-BM70BLES1F2
 - HVIN: BM70BLES1F2
- Europe/CE
- Japan/MIC: 202-SMD069
- Korea/KCC: MSIP-CRM-mcp-BM70BLES1FC2
- Taiwan/NCC No: CCAN15LP0500T1
- China/SRRC: CMIIT ID: 2015DJ7135

The BM71 module (BM71BLES1FC2) has received the regulatory approval for the following:

- BT SIG/QDID:74246
- United States/FCC ID: A8TBM71S2
- Canada
 - IC ID: 12246A-BM71S2
 - HVIN: BM71BLES1FC2
- Europe/CE
- Japan/MIC: 005-101150
- Korea/KCC: MSIP-CRM-mcp-BM71BLES1FC2
- Taiwan/NCC No: CCAN16LP0010T5

A.1 REGULATORY APPROVAL

This section outlines the regulatory information for the BM70/BM71 for the following countries:

- United States
- Canada
- Europe
- Japan
- Korea
- Taiwan
- China
- Other Regulatory Jurisdictions

A.1.1 UNITED STATES

The BM70/BM71 has received Federal Communications Commission (FCC) CFR47 Telecommunications, Part 15 Subpart C "Intentional Radiators" modular approval in accordance with Part 15.212 Modular Transmitter approval. Modular approval allows the end user to integrate the BM70/BM71 into a finished product without obtaining subsequent and separate FCC approvals for intentional radiation, provided no changes or modifications are made to the module circuitry. Changes or modifications could void the user's authority to operate the equipment. The end user must

comply with all of the instructions provided by the Grantee, which indicate installation and/or operating conditions necessary for compliance.

The finished product is required to comply with all applicable FCC equipment authorizations regulations, requirements and equipment functions not associated with the transmitter module portion. For example, compliance must be demonstrated to regulations for other transmitter components within the host product; to requirements for unintentional radiators (Part 15 Subpart B "Unintentional Radiators"), such as digital devices, computer peripherals, radio receivers, etc.; and to additional authorization requirements for the non-transmitter functions on the transmitter module (i.e., Verification, or Declaration of Conformity) (e.g., transmitter modules may also contain digital logic functions) as appropriate.

A.1.2 LABELING AND USER INFORMATION REQUIREMENTS

The BM70/BM71 has been labeled with its own FCC ID number, and if the FCC ID is not visible when the module is installed inside another device, then the outside of the finished product into which the module is installed must also display a label referring to the enclosed module. This exterior label can use wording as follows:

For the BM70:

Contains Transmitter Module FCC ID:A8TBM70ABCDEFGH or Contains FCC ID: A8TBM70ABCDEFGH This device complies with Part 15 of the FCC Rules. Operation is subject to the following two conditions: (1) this device may not cause harmful interference, and (2) this device must accept any interference received, including interference that may cause undesired operation

For the BM71:

Contains Transmitter Module FCC ID: A8TBM71S2 or Contains FCC ID: A8TBM71S2 This device complies with Part 15 of the FCC Rules. Operation is subject to the following two conditions: (1) this device may not cause harmful interference, and (2) this device must accept any interference received, including interference that may cause undesired operation
--

On the BM71, due to the limited module size (9.0 mm x 11.5 mm), the FCC identifier is displayed in the data sheet only and it can not be displayed on the module label.

BM70/BM71

A user's manual for the finished product should include the following statement:

This equipment has been tested and found to comply with the limits for a Class B digital device, pursuant to part 15 of the FCC Rules. These limits are designed to provide reasonable protection against harmful interference in a residential installation. This equipment generates, uses and can radiate radio frequency energy, and if not installed and used in accordance with the instructions, may cause harmful interference to radio communications. However, there is no guarantee that interference will not occur in a particular installation. If this equipment does cause harmful interference to radio or television reception, which can be determined by turning the equipment off and on, the user is encouraged to try to correct the interference by one or more of the following measures:

- Reorient or relocate the receiving antenna.
- Increase the separation between the equipment and receiver.
- Connect the equipment into an outlet on a circuit different from that to which the receiver is connected.
- Consult the dealer or an experienced radio/TV technician for help.

Additional information on labeling and user information requirements for Part 15 devices can be found in KDB Publication 784748, which is available at the FCC Office of Engineering and Technology (OET) Laboratory Division Knowledge Database (KDB) <http://apps.fcc.gov/oetcf/kdb/index.cfm>.

A.1.3 RF EXPOSURE

All transmitters regulated by FCC must comply with RF exposure requirements. KDB 447498 General RF Exposure Guidance provides guidance in determining whether proposed or existing transmitting facilities, operations or devices comply with limits for human exposure to Radio Frequency (RF) fields adopted by the Federal Communications Commission (FCC).

From the FCC Grant: Output power listed is conducted. This grant is valid only when the module is sold to OEM integrators and must be installed by the OEM or OEM integrators. This transmitter is restricted for use with the specific antenna(s) tested in this application for Certification and must not be co-located or operating in conjunction with any other antenna or transmitters within a host device, except in accordance with FCC multi-transmitter product procedures. This module is approved for installation into mobile or/and portable host platforms

A.1.4 HELPFUL WEB SITES

Federal Communications Commission (FCC): <http://www.fcc.gov>

FCC Office of Engineering and Technology (OET) Laboratory Division Knowledge Database (KDB): <http://apps.fcc.gov/oetcf/kdb/index.cfm>.

A.2 Canada

The BM70/BM71 has been certified for use in Canada under Industry Canada (IC) Radio Standards Specification (RSS) RSS-247 and RSS-Gen. Modular approval permits the installation of a module in a host device without the need to recertify the device.

A.2.1 LABELING AND USER INFORMATION REQUIREMENTS

Labeling Requirements for the Host Device (from Section 3.1, RSS-Gen, Issue 4, November 2014): The host device shall be properly labeled to identify the module within the host device.

On BM71, due to the limited module size (9.0 mm x 11.5 mm) the IC identifier is displayed in the data sheet only and can not be displayed on the module label.

The Industry Canada certification label of a module shall be clearly visible at all times when installed in the host device, otherwise the host device must be labeled to display the Industry Canada certification number of the module, preceded by the words "Contains transmitter module", or the word "Contains", or similar wording expressing the same meaning, as follows:

For the BM70:

Contains transmitter module
IC: 12246A-BM70BLES1F2

For the BM71:

Contains transmitter module
IC: 12246A-BM71S2

User Manual Notice for License-Exempt Radio Apparatus (from Section 8.4, RSS-Gen, Issue 4, November 2014): User manuals for license-exempt radio apparatus shall contain the following or equivalent notice in a conspicuous location in the user manual or alternatively on the device or both:

This device complies with Industry Canada license-exempt RSS standard(s). Operation is subject to the following two conditions: (1) this device may not cause interference, and (2) this device must accept any interference, including interference that may cause undesired operation of the device.

Le présent appareil est conforme aux CNR d'Industrie Canada applicables aux appareils radio exempts de licence. L'exploitation est autorisée aux deux conditions suivantes: (1) l'appareil ne doit pas produire de brouillage, et (2) l'utilisateur de l'appareil doit accepter tout brouillage radioélectrique subi, même si le brouillage est susceptible d'en compromettre le fonctionnement.

Transmitter Antenna (from Section 8.3, RSS-Gen, Issue 4, November 2014): User manuals for transmitters shall display the following notice in a conspicuous location:

Under Industry Canada regulations, this radio transmitter may only operate using an antenna of a type and maximum (or lesser) gain approved for the transmitter by Industry Canada. To reduce potential radio interference to other users, the antenna type and its gain should be so chosen that the equivalent isotropically radiated power (e.i.r.p.) is not more than that necessary for successful communication.

Conformément à la réglementation d'Industrie Canada, le présent émetteur radio peut fonctionner avec une antenne d'un type et d'un gain maximal (ou inférieur) approuvé pour l'émetteur par Industrie Canada. Dans le but de réduire les risques de brouillage radioélectrique à l'intention des autres utilisateurs, il faut choisir le type d'antenne et son gain de sorte que la puissance isotrope rayonnée équivalente (p.i.r.e.) ne dépasse pas l'intensité nécessaire à l'établissement d'une communication satisfaisante.

The preceding notice may be affixed to the device instead of displayed in the user manual.

A.2.2 RF EXPOSURE

All transmitters regulated by IC must comply with RF exposure requirements listed in RSS-102 - Radio Frequency (RF) Exposure Compliance of Radio communication Apparatus (All Frequency Bands).

A.2.3 HELPFUL WEB SITES

Industry Canada: <http://www.ic.gc.ca/>

A.3 Europe

The BM70/BM71 is an R&TTE Directive assessed radio module that is CE marked and has been manufactured and tested with the intention of being integrated into a final product.

The BM70/BM71 has been tested to R&TTE Directive 1999/5/EC Essential Requirements for Health and Safety (Article (3.1(a)), Electromagnetic Compatibility (EMC) (Article 3.1(b)), and Radio (Article 3.2) and are summarized in [Table A-1/Table A-2](#). A Notified Body Opinion has also been issued.

The R&TTE Compliance Association provides guidance on modular devices in the document "*Technical Guidance Note 01*" which is available for download from the following location:

http://www.rteca.com/html/download_area.htm.

To maintain conformance to the testing listed in [Table A-1/Table A-2: European Compliance Testing](#), the module shall be installed in accordance with the installation instructions in this data sheet and shall not be modified.

When integrating a radio module into a completed product the integrator becomes the manufacturer of the final product and is therefore responsible for demonstrating compliance of the final product with the essential requirements of the R&TTE Directive.

A.3.1 LABELING AND USER INFORMATION REQUIREMENTS

The label on the final product which contains the BM70/BM71 must follow CE marking requirements. The R&TTE Compliance Association **Technical Guidance Note 01** provides guidance on final product CE marking.

A.3.2 ANTENNA REQUIREMENTS

From the R&TTE Compliance Association document *Technical Guidance Note 01*.

Provided the integrator installing an assessed radio module with an integral or specific antenna and installed in conformance with the radio module manufacturer's installation instructions requires no further evaluation. Under Article 3.2 of the R&TTE Directive and does not require further involvement of an R&TTE Directive Notified Body for the final product. [Section 2.2.4]

BM70/BM71

The European Compliance Testing listed in [Table A-1](#) and [Table A-2](#) were performed using the integral ceramic chip antenna.

TABLE A-1: EUROPEAN COMPLIANCE TESTING (BM70)

Certification	Standards	Article	Laboratory	Report Number
Safety	EN60950-1:2006/A11:2009/A1:2010/A12:2011/A2:2013	[3.1(a)]	TUV Rheinland	10051261 003
Health	EN62479:2010			10053580 001
EMC	EN301489-1 V1.9.2	[3.1(b)]		10051137 002
	EN301489-17 V2.2.1			
Radio	EN300328 V1.9.1	(3.2)		10053580 001
Notified Body Opinion	CE0197	—		10048935 001

TABLE A-2: EUROPEAN COMPLIANCE TESTING (BM71)

Certification	Standards	Article	Laboratory	Report Number
Safety	EN60950-1:2006/A11:2009/A1:2010/A12:2011/A2:2013	[3.1(a)]	TUV Rheinland	10053210 001
Health	EN62479:2010			10053433 001
EMC	EN301489-1 V1.9.2	[3.1(b)]		10052964 001
	EN301489-17 V2.2.1			
Radio	EN300328 V1.9.1	(3.2)		10053433 001
Notified Body Opinion	CE0197	—		10048936 001

A.3.3 HELPFUL WEB SITES

A document that can be used as a starting point in understanding the use of Short Range Devices (SRD) in Europe is the European Radio Communications Committee (ERC) Recommendation 70-03 E, which can be downloaded from the European Radio Communications Office (ERO) at: <http://www.ero.dk/>. Additional helpful web sites are:

- Radio and Telecommunications Terminal Equipment (R&TTE):
http://ec.europa.eu/enterprise/rtte/index_en.htm
- European Conference of Postal and Telecommunications Administrations (CEPT):
<http://www.cept.org>
- European Telecommunications Standards Institute (ETSI):
<http://www.etsi.org>
- European Radio Communications Office (ERO):
<http://www.ero.dk>
- The Radio and Telecommunications Terminal Equipment Compliance Association (R&TTE CA):
<http://www.rtteca.com>

A.4 Japan

The BM70/BM71 has received type certification and is labeled with its own technical conformity mark and certification number as required to conform to the technical standards regulated by the Ministry of Internal Affairs and Communications (MIC) of Japan pursuant to the Radio Act of Japan.

Integration of this module into a final product does not require additional radio certification provided installation instructions are followed and no modifications of the module are allowed. Additional testing may be required:

- If the host product is subject to electrical appliance safety (for example, powered from an AC mains), the host product may require Product Safety Electrical Appliance and Material (PSE) testing. The integrator should contact their conformance laboratory to determine if this testing is required.
- There is an voluntary Electromagnetic Compatibility (EMC) test for the host product administered by VCCI: http://www.vcci.jp/vcci_e/index.html

A.4.1 LABELING AND USER INFORMATION REQUIREMENTS

The label on the final product which contains the BM70/BM71 must follow Japan marking requirements. The integrator of the module should refer to the labeling requirements for Japan available at the Ministry of Internal Affairs and Communications (MIC) website.

The BM70 is labeled with its own technical conformity mark and certification number. The final product in which this module is being used must have a label referring to the type certified module inside:

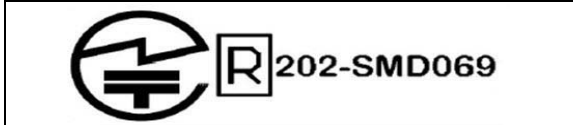

On BM71, due to the limited module size (9.0 mm x 11.5 mm) the Japan identifier is displayed in the data sheet only and can not be displayed on the module label. The final product in which this module is being used must have a label referring to the type certified module inside:



A.4.2 HELPFUL WEB SITES

Ministry of Internal Affairs and Communications (MIC): <http://www.tele.soumu.go.jp/e/index.htm>

Association of Radio Industries and Businesses (ARIB): <http://www.arib.or.jp/english/>

A.5 Korea

The BM70/BM71 has received certification of conformity in accordance with the Radio Waves Act. Integration of this module into a final product does not require additional radio certification provided installation instructions are followed and no modifications of the module are allowed.

A.5.1 LABELING AND USER INFORMATION REQUIREMENTS

The label on the final product which contains the BM70/BM71 must follow KC marking requirements. The integrator of the module should refer to the labeling requirements for Korea available on the Korea Communications Commission (KCC) website.

The BM70 module is labeled with its own KC mark. The final product requires the KC mark and certificate number of the module:



On the BM71, due to the limited module size (9.0 mm x 11.5 mm) the KC mark and identifier is displayed in the data sheet only and can not be displayed on the module label. The final product requires the KC mark and certificate number of the module:



A.5.2 HELPFUL WEB SITES

Korea Communications Commission (KCC): <http://www.kcc.go.kr>

National Radio Research Agency (RRA): <http://rra.go.kr>

A.6 Taiwan

The BM70/BM71 has received compliance approval in accordance with the Telecommunications Act. Customers seeking to use the compliance approval in their product should contact Microchip Technology sales or distribution partners to obtain a Letter of Authority.

Integration of this module into a final product does not require additional radio certification provided installation instructions are followed and no modifications of the module are allowed.

A.6.1 LABELING AND USER INFORMATION REQUIREMENTS

The BM70 is labeled with its own NCC mark and certificate number as follows:

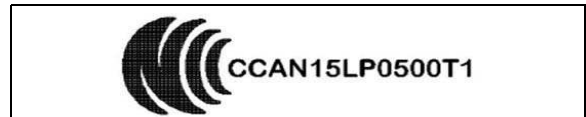

On the BM71, due to the limited module size (9.0 mm x 11.5 mm) the NCC mark and identifier is displayed in the data sheet only and can not be displayed on the module label.



The user's manual should contain following warning (for RF device) in traditional Chinese:

注意！

依據 低功率電波輻射性電機管理辦法

第十二條 經型式認證合格之低功率射頻電機，非經許可，

公司、商號或使用者均不得擅自變更頻率、加大功率或變更原設計

之特性及功能。

BM70/BM71

第十四條 低功率射頻電機之使用不得影響飛航安全及干擾合法通信；

經發現有干擾現象時，應立即停用，並改善至無干擾時方得繼續使用。

前項合法通信，指依電信規定作業之無線電信。

低功率射頻電機須忍受合法通信或工業、科學及醫療用電波輻射性

電機設備之干擾。

A.6.2 HELPFUL WEB SITES

National Communications Commission (NCC):
<http://www.ncc.gov.tw>

A.7 China

The BM70 has received certification of conformity in accordance with the China MIIT Notice 2014-01 of State Radio Regulation Committee (SRRC) certification scheme. Integration of this module into a final product does not require additional radio certification, provided installation instructions are followed and no modifications of the module are allowed.

A.7.1 LABELING AND USER INFORMATION REQUIREMENTS

The BM70 module is labeled with its own CMIIT ID as follows:

CMIIT ID: 2015DJ7135

When Host system is using an approved Full Modular Approval (FMA) radio: The host must carry a label containing the statement “This device contains SRRC approved Radio module CMIIT ID: 2015DJ7135”.

A.8 Other Regulatory Jurisdictions

Should other regulatory jurisdiction certification be required by the customer, or the customer need to recertify the module for other reasons, contact Microchip for the required utilities and documentation.

APPENDIX B: REVISION HISTORY

B.1 Revision A (October 2015)

This is the initial released version of the document.

B.2 Revision B (October 2015)

This revision includes the following changes as well as minor updates to text and formatting, which were incorporated throughout the document.

TABLE B-1: MAJOR SECTION UPDATES

Section	Update Description
Section “Features”	This section is updated with certification informations. The data from this section has been reformatted and distributed in other sections.
Section “MAC/Baseband/Higher Layer Features” , Section “Power Management” , “Operating Conditions” , and Section “Antenna”	These sections are newly added.
Section “General Description”	This section was previously placed in chapter 1 and has been moved here.
Section 1.0 “Device Overview”	Table 1-2 , Table 1-4 , and Table 1-5 are added.
Section 2.0 “Application information”	This chapter contains information that was previously located in Appendix A and Electrical Characteristics.
Section 8.0 “Ordering Guide”	Table 8-1 is updated with Y-axis information and certification information.
Section Appendix B: “Revision History”	This section is updated with images for the Certification Marking and their numbers. The regulatory information is updated to be the latest.
Section 5.0 “Electrical Characteristics”	Table 5-3 is added

Revision C (November 2015)

Updated [Appendix A: “Certification Notices”](#).

Revision D (March 2016)

This revision includes the following changes as well as minor updates to text and formatting, which were incorporated throughout the document.

Section	Update Description
1.1 “Interface Description”	This section is updated with a note. Updated Figure 1-1 , Figure 1-2 , Figure 1-6
2.1 “Reference Schematics”	Figure 2-1 through Figure 2-8 , Figure 2-10 , Figure 5-1 , Figure 5-2 , Figure 2-11 , Figure 4-1 and Table 4-1 , Table 8-1
5.1 “Absolute Maximum Ratings”	Updated this section.
5.2.1 “Tx/Rx current consumption details”	Updated this section with new content.
8.0 “Ordering Guide”	This section is updated with a note.
Appendix A: “Certification Notices”	Content has been updated

BM70/71

NOTES:

THE MICROCHIP WEB SITE

Microchip provides online support via our WWW site at www.microchip.com. This web site is used as a means to make files and information easily available to customers. Accessible by using your favorite Internet browser, the web site contains the following information:

- **Product Support** – Data sheets and errata, application notes and sample programs, design resources, user's guides and hardware support documents, latest software releases and archived software
- **General Technical Support** – Frequently Asked Questions (FAQ), technical support requests, online discussion groups, Microchip consultant program member listing
- **Business of Microchip** – Product selector and ordering guides, latest Microchip press releases, listing of seminars and events, listings of Microchip sales offices, distributors and factory representatives

CUSTOMER CHANGE NOTIFICATION SERVICE

Microchip's customer notification service helps keep customers current on Microchip products. Subscribers will receive e-mail notification whenever there are changes, updates, revisions or errata related to a specified product family or development tool of interest.

To register, access the Microchip web site at www.microchip.com. Under "Support", click on "Customer Change Notification" and follow the registration instructions.

CUSTOMER SUPPORT

Users of Microchip products can receive assistance through several channels:

- Distributor or Representative
- Local Sales Office
- Field Application Engineer (FAE)
- Technical Support

Customers should contact their distributor, representative or Field Application Engineer (FAE) for support. Local sales offices are also available to help customers. A listing of sales offices and locations is included in the back of this document.

Technical support is available through the web site at: <http://microchip.com/support>

BM70/71

NOTES:

Note the following details of the code protection feature on Microchip devices:

- Microchip products meet the specification contained in their particular Microchip Data Sheet.
- Microchip believes that its family of products is one of the most secure families of its kind on the market today, when used in the intended manner and under normal conditions.
- There are dishonest and possibly illegal methods used to breach the code protection feature. All of these methods, to our knowledge, require using the Microchip products in a manner outside the operating specifications contained in Microchip's Data Sheets. Most likely, the person doing so is engaged in theft of intellectual property.
- Microchip is willing to work with the customer who is concerned about the integrity of their code.
- Neither Microchip nor any other semiconductor manufacturer can guarantee the security of their code. Code protection does not mean that we are guaranteeing the product as "unbreakable."

Code protection is constantly evolving. We at Microchip are committed to continuously improving the code protection features of our products. Attempts to break Microchip's code protection feature may be a violation of the Digital Millennium Copyright Act. If such acts allow unauthorized access to your software or other copyrighted work, you may have a right to sue for relief under that Act.

Information contained in this publication regarding device applications and the like is provided only for your convenience and may be superseded by updates. It is your responsibility to ensure that your application meets with your specifications. MICROCHIP MAKES NO REPRESENTATIONS OR WARRANTIES OF ANY KIND WHETHER EXPRESS OR IMPLIED, WRITTEN OR ORAL, STATUTORY OR OTHERWISE, RELATED TO THE INFORMATION, INCLUDING BUT NOT LIMITED TO ITS CONDITION, QUALITY, PERFORMANCE, MERCHANTABILITY OR FITNESS FOR PURPOSE. Microchip disclaims all liability arising from this information and its use. Use of Microchip devices in life support and/or safety applications is entirely at the buyer's risk, and the buyer agrees to defend, indemnify and hold harmless Microchip from any and all damages, claims, suits, or expenses resulting from such use. No licenses are conveyed, implicitly or otherwise, under any Microchip intellectual property rights unless otherwise stated.

Microchip received ISO/TS-16949:2009 certification for its worldwide headquarters, design and wafer fabrication facilities in Chandler and Tempe, Arizona; Gresham, Oregon and design centers in California and India. The Company's quality system processes and procedures are for its PIC® MCUs and dsPIC® DSCs, KEELOQ® code hopping devices, Serial EEPROMs, microperipherals, nonvolatile memory and analog products. In addition, Microchip's quality system for the design and manufacture of development systems is ISO 9001:2000 certified.

**QUALITY MANAGEMENT SYSTEM
CERTIFIED BY DNV
= ISO/TS 16949 =**

Trademarks

The Microchip name and logo, the Microchip logo, AnyRate, dsPIC, FlashFlex, flexPWR, Heldo, JukeBlox, KeeLoq, KeeLoq logo, Klear, LANCheck, LINK MD, MediaLB, MOST, MOST logo, MPLAB, OptoLyzer, PIC, PICSTART, PIC32 logo, RightTouch, SpyNIC, SST, SST Logo, SuperFlash and UNI/O are registered trademarks of Microchip Technology Incorporated in the U.S.A. and other countries.

ClockWorks, The Embedded Control Solutions Company, ETHERSYNCH, Hyper Speed Control, HyperLight Load, IntelliMOS, mTouch, Precision Edge, and QUIET-WIRE are registered trademarks of Microchip Technology Incorporated in the U.S.A.

Analog-for-the-Digital Age, Any Capacitor, AnyIn, AnyOut, BodyCom, chipKIT, chipKIT logo, CodeGuard, dsPICDEM, dsPICDEM.net, Dynamic Average Matching, DAM, ECAN, EtherGREEN, In-Circuit Serial Programming, ICSP, Inter-Chip Connectivity, JitterBlocker, KlearNet, KlearNet logo, MiWi, motorBench, MPASM, MPF, MPLAB Certified logo, MPLIB, MPLINK, MultiTRAK, NetDetach, Omniscient Code Generation, PICDEM, PICDEM.net, PICKit, PICtail, PureSilicon, RightTouch logo, REAL ICE, Ripple Blocker, Serial Quad I/O, SQL, SuperSwitcher, SuperSwitcher II, Total Endurance, TSHARC, USBCheck, VariSense, ViewSpan, WiperLock, Wireless DNA, and ZENA are trademarks of Microchip Technology Incorporated in the U.S.A. and other countries.

SQTP is a service mark of Microchip Technology Incorporated in the U.S.A.

Silicon Storage Technology is a registered trademark of Microchip Technology Inc. in other countries.

GestIC is a registered trademarks of Microchip Technology Germany II GmbH & Co. KG, a subsidiary of Microchip Technology Inc., in other countries.

All other trademarks mentioned herein are property of their respective companies.

© 2015-2016, Microchip Technology Incorporated, Printed in the U.S.A., All Rights Reserved.

ISBN:978-1-5224-0410-1



MICROCHIP

Worldwide Sales and Service

AMERICAS

Corporate Office
2355 West Chandler Blvd.
Chandler, AZ 85224-6199
Tel: 480-792-7200
Fax: 480-792-7277
Technical Support:
<http://www.microchip.com/support>
Web Address:
www.microchip.com

Atlanta
Duluth, GA
Tel: 678-957-9614
Fax: 678-957-1455

Austin, TX
Tel: 512-257-3370

Boston
Westborough, MA
Tel: 774-760-0087
Fax: 774-760-0088

Chicago
Itasca, IL
Tel: 630-285-0071
Fax: 630-285-0075

Cleveland
Independence, OH
Tel: 216-447-0464
Fax: 216-447-0643

Dallas
Addison, TX
Tel: 972-818-7423
Fax: 972-818-2924

Detroit
Novi, MI
Tel: 248-848-4000

Houston, TX
Tel: 281-894-5983

Indianapolis
Noblesville, IN
Tel: 317-773-8323
Fax: 317-773-5453

Los Angeles
Mission Viejo, CA
Tel: 949-462-9523
Fax: 949-462-9608

New York, NY
Tel: 631-435-6000

San Jose, CA
Tel: 408-735-9110

Canada - Toronto
Tel: 905-673-0699
Fax: 905-673-6509

ASIA/PACIFIC

Asia Pacific Office
Suites 3707-14, 37th Floor
Tower 6, The Gateway
Harbour City, Kowloon

Hong Kong
Tel: 852-2943-5100
Fax: 852-2401-3431

Australia - Sydney
Tel: 61-2-9868-6733
Fax: 61-2-9868-6755

China - Beijing
Tel: 86-10-8569-7000
Fax: 86-10-8528-2104

China - Chengdu
Tel: 86-28-8665-5511
Fax: 86-28-8665-7889

China - Chongqing
Tel: 86-23-8980-9588
Fax: 86-23-8980-9500

China - Dongguan
Tel: 86-769-8702-9880

China - Hangzhou
Tel: 86-571-8792-8115
Fax: 86-571-8792-8116

China - Hong Kong SAR
Tel: 852-2943-5100
Fax: 852-2401-3431

China - Nanjing
Tel: 86-25-8473-2460
Fax: 86-25-8473-2470

China - Qingdao
Tel: 86-532-8502-7355
Fax: 86-532-8502-7205

China - Shanghai
Tel: 86-21-5407-5533
Fax: 86-21-5407-5066

China - Shenyang
Tel: 86-24-2334-2829
Fax: 86-24-2334-2393

China - Shenzhen
Tel: 86-755-8864-2200
Fax: 86-755-8203-1760

China - Wuhan
Tel: 86-27-5980-5300
Fax: 86-27-5980-5118

China - Xian
Tel: 86-29-8833-7252
Fax: 86-29-8833-7256

ASIA/PACIFIC

China - Xiamen
Tel: 86-592-2388138
Fax: 86-592-2388130

China - Zhuhai
Tel: 86-756-3210040
Fax: 86-756-3210049

India - Bangalore
Tel: 91-80-3090-4444
Fax: 91-80-3090-4123

India - New Delhi
Tel: 91-11-4160-8631
Fax: 91-11-4160-8632

India - Pune
Tel: 91-20-3019-1500

Japan - Osaka
Tel: 81-6-6152-7160
Fax: 81-6-6152-9310

Japan - Tokyo
Tel: 81-3-6880-3770
Fax: 81-3-6880-3771

Korea - Daegu
Tel: 82-53-744-4301
Fax: 82-53-744-4302

Korea - Seoul
Tel: 82-2-554-7200
Fax: 82-2-558-5932 or
82-2-558-5934

Malaysia - Kuala Lumpur
Tel: 60-3-6201-9857
Fax: 60-3-6201-9859

Malaysia - Penang
Tel: 60-4-227-8870
Fax: 60-4-227-4068

Philippines - Manila
Tel: 63-2-634-9065
Fax: 63-2-634-9069

Singapore
Tel: 65-6334-8870
Fax: 65-6334-8850

Taiwan - Hsin Chu
Tel: 886-3-5778-366
Fax: 886-3-5770-955

Taiwan - Kaohsiung
Tel: 886-7-213-7828

Taiwan - Taipei
Tel: 886-2-2508-8600
Fax: 886-2-2508-0102

Thailand - Bangkok
Tel: 66-2-694-1351
Fax: 66-2-694-1350

EUROPE

Austria - Wels
Tel: 43-7242-2244-39
Fax: 43-7242-2244-393

Denmark - Copenhagen
Tel: 45-4450-2828
Fax: 45-4485-2829

France - Paris
Tel: 33-1-69-53-63-20
Fax: 33-1-69-30-90-79

Germany - Dusseldorf
Tel: 49-2129-3766400

Germany - Karlsruhe
Tel: 49-721-625370

Germany - Munich
Tel: 49-89-627-144-0
Fax: 49-89-627-144-44

Italy - Milan
Tel: 39-0331-742611
Fax: 39-0331-466781

Italy - Venice
Tel: 39-049-7625286

Netherlands - Druen
Tel: 31-416-690399
Fax: 31-416-690340

Poland - Warsaw
Tel: 48-22-3325737

Spain - Madrid
Tel: 34-91-708-08-90
Fax: 34-91-708-08-91

Sweden - Stockholm
Tel: 46-8-5090-4654

UK - Wokingham
Tel: 44-118-921-5800
Fax: 44-118-921-5820

07/14/15