

## 20-Channel, Serial-Input, Vacuum-Fluorescent Display Driver for Anode/Grid

### Features

- ▶ HVCMOS® technology for high performance
- ▶ Operating voltage up to 80V
- ▶ High speed source driver
- ▶ 5.0V CMOS logic circuitry
- ▶ Up to 5.0MHz data input rate
- ▶ Excellent noise immunity
- ▶ Flexible high voltage supplies

### General Description

The Supertex HV5812 is a 20-channel, serial input, vacuum-fluorescent display driver. It combines a 20-bit CMOS shift register, data latches, and control circuitry with high voltage MOSFET outputs. The HV5812 is primarily designed for vacuum-fluorescent displays.

The CMOS shift register and latches allow direct interfacing with microprocessor based systems. Data input rates are typically over 5.0MHz with 5.0V logic supply. Especially useful for interdigit blanking, the BLANKING input disables the output source drives and turns on the sink drivers. Use with TTL may require external pull-up resistors to ensure an input logic high.

### Functional Block Diagram

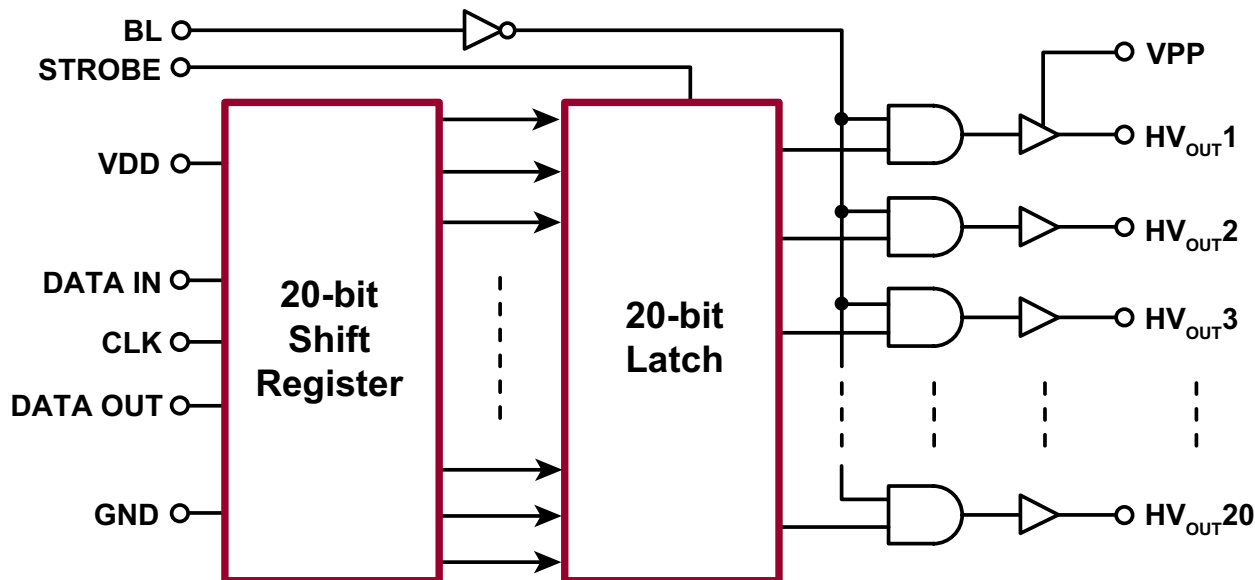

## Ordering Information

Part Number	Package	Packing
HV5812P-G	28-Lead PDIP	13/Tube
HV5812PJ-G	28-Lead PLCC	38/Tube
HV5812PJ-G M904	28-Lead PLCC	500/Reel
HV5812WG-G	28-Lead SOW	1000/Reel

-G denotes a lead (Pb)-free / RoHS compliant package

## Absolute Maximum Ratings

Parameter	Value
Supply voltage, $V_{DD}$	-0.5V to +7.5V
Supply voltage, $V_{PP}$	-0.5V to +90V
Logic input levels	-0.3V to $V_{DD} + 0.3V$
Maximum junction temperature	125°C
Storage temperature range	-55°C to +150°C
Power dissipation:	
28-Lead PDIP	2000mW
28-Lead PLCC	1900mW
28-Lead SOW	1700mW

Absolute Maximum Ratings are those values beyond which damage to the device may occur. Functional operation under these conditions is not implied. Continuous operation of the device at the absolute rating level may affect device reliability. All voltages are referenced to GND.

## Recommended Operating Conditions

Sym	Parameter	Min	Max	Units
$V_{DD}$	Supply voltage	4.5	5.5	V
$V_{PP}$	Supply voltage	20	80	V
$T_j$	Operating junction temperature	-40	+125	°C

Power-up sequence should be the following:

1. Connect ground.
2. Apply  $V_{DD}$ .
3. Set all inputs (Data, CLK, etc.) to a known state.
4. Apply  $V_{PP}$ .

The  $V_{PP}$  should not drop below  $V_{DD}$  during operation.

Power-down sequence should be the reverse of the above.

## Typical Thermal Resistance

Package	$\theta_{ja}$
28-Lead PDIP	43°C/W
28-Lead PLCC	48°C/W
28-Lead SOW	55°C/W

## Pin Configuration

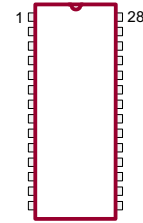

28-Lead PDIP

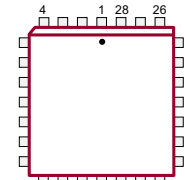

28-Lead PLCC

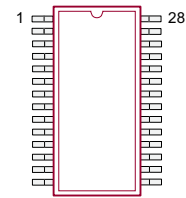

28-Lead SOW

## Product Marking

Top Marking



Bottom Marking

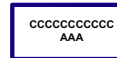

YY = Year Sealed  
 WW = Week Sealed  
 L = Lot Number  
 C = Country of Origin\*  
 A = Assembler ID\*  
 — = "Green" Packaging

\*May be part of top marking

Package may or may not include the following marks: Si or

28-Lead PDIP

Top Marking

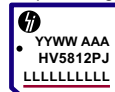

Bottom Marking

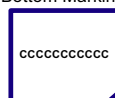

YY = Year Sealed  
 WW = Week Sealed  
 L = Lot Number  
 A = Assembler ID  
 C = Country of Origin\*  
 — = "Green" Packaging

\*May be part of top marking

Package may or may not include the following marks: Si or

28-Lead PLCC

Top Marking

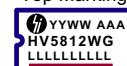

Bottom Marking

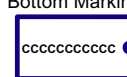

YY = Year Sealed  
 WW = Week Sealed  
 A = Assembler ID  
 L = Lot Number  
 C = Country of Origin\*  
 — = "Green" Packaging

\*May be part of top marking

Package may or may not include the following marks: Si or

28-Lead SOW

## Electrical Characteristics

**DC Characteristics** (over recommended operating conditions,  $T_A = 25^\circ\text{C}$ , unless otherwise noted)

Sym	Parameter	Min	Typ	Max	Units	Conditions	
$I_{DSS}$	Output leakage current	-	-5.0	-15	$\mu\text{A}$	$V_{OUT} = 0\text{V}$ , $T_A = +70^\circ\text{C}$	
$V_{OH}$	High-level output	HV <sub>OUT</sub>	78	78.5	-	V	$I_{OUT} = -25\text{mA}$ , $V_{PP} = 80\text{V}$ , $T_j = +25^\circ\text{C}$
			77	78	-		$I_{OUT} = -25\text{mA}$ , $V_{PP} = 80\text{V}$ , $T_j = +125^\circ\text{C}$
		DATA OUT	4.5	4.7	-	V	$I_{OUT} = -200\mu\text{A}$ , $V_{DD} = 5.0\text{V}$
$V_{OL}$	Low-level output	HV <sub>OUT</sub>	-	1.5	3.0	V	$I_{OUT} = 1.0\text{mA}$ , $T_j = +25^\circ\text{C}$ , $V_{DD} = 5.0\text{V}$
			-	2.3	4.0		$I_{OUT} = 1.0\text{mA}$ , $T_j = +125^\circ\text{C}$ , $V_{DD} = 5.0\text{V}$
		DATA OUT	-	200	250	V	$I_{OUT} = +200\mu\text{A}$ , $V_{DD} = 5.0\text{V}$
$I_{SINK}$	Output pull-down current	2.0	3.5	-	mA	$V_{OUT} = 5.0\text{V}$ to $V_{PP}$ , $V_{DD} = 5.0\text{V}$	
$V_{IH}$	High level logic input voltage	3.5	-	5.3	V	$V_{DD} = 5.0\text{V}$	
$V_{IL}$	Low level logic input voltage	-0.3	-	0.8	V	---	
$I_{IH}$	High level logic input current	-	0.05	0.5	$\mu\text{A}$	$V_{IN} = V_{DD}$ , $V_{DD} = 5.0\text{V}$	
$I_{IL}$	Low level logic input current	-	-0.05	-0.5	$\mu\text{A}$	$V_{IN} = 0.8\text{V}$ , $V_{DD} = 5.0\text{V}$	
$I_{DDQ}$	Quiescent $V_{DD}$ supply current	-	100	300	$\mu\text{A}$	All outputs high, $V_{DD} = 5.0\text{V}$	
		-	100	300		All outputs low, $V_{DD} = 5.0\text{V}$	
$I_{PPQ}$	Quiescent $V_{PP}$ supply current	-	10	100	$\mu\text{A}$	All outputs high, no load	
		-	10	100		All outputs low, no load	

**AC Characteristics** (over recommended operating conditions,  $T_A = 25^\circ\text{C}$ , unless otherwise noted)

$t_{PHL}$	Blanking to output delay	-	2000	-	ns	$C_L = 30\text{pF}$ , 50% to 50%, $V_{DD} = 5.0\text{V}$
$t_{PLH}$		-	1000	-		
$t_f$	Output fall time	-	1450	-	ns	$C_L = 30\text{pF}$ , 90% to 10%, $V_{DD} = 5.0\text{V}$
$t_r$	Output rise time	-	650	-	ns	$C_L = 30\text{pF}$ , 10% to 90%, $V_{DD} = 5.0\text{V}$
$t_{su}$	Data set-up time	75	-	-	ns	See timing diagram
$t_h$	Data hold time	75	-	-	ns	See timing diagram
$t_{pwd}$	Minimum data pulse width	150	-	-	ns	See timing diagram
$t_{pwclk}$	Minimum clock pulse width	150	-	-	ns	See timing diagram
$t_{cks}$	Minimum time between clock activation and strobe	300	-	-	ns	See timing diagram
$t_{pws}$	Minimum strobe pulse width	100	-	-	ns	See timing diagram
$t_{sto}$	Typical time between strobe activation and output transition	-	500	-	ns	See timing diagram
$f_{CLK}$	Maximum clock frequency	-	8.0	-	MHz	$T_j = +25^\circ\text{C}$ , $V_{DD} = 5.0\text{V}$
		-	5.0	-		$T_j = +125^\circ\text{C}$ , $V_{DD} = 5.0\text{V}$

Function Table

Serial Data Input	Clock Input	Shift Register Contents					Serial Data Output	Strobe Input	Latch Content					Blanking	Output Content					
		I <sub>1</sub>	I <sub>2</sub>	I <sub>3</sub> ...	I <sub>N-1</sub>	I <sub>N</sub>			I <sub>1</sub>	I <sub>2</sub>	I <sub>3</sub> ...	I <sub>N-1</sub>	I <sub>N</sub>		I <sub>1</sub>	I <sub>2</sub>	I <sub>3</sub> ...	I <sub>N-1</sub>	I <sub>N</sub>	
H	L to H	H	R <sub>1</sub>	R <sub>2</sub> ...	R <sub>N-2</sub>	R <sub>N-1</sub>	R <sub>N-1</sub>	-	-	-	-	-	-	-	-	-	-	-	-	
L	L to H	L	R <sub>1</sub>	R <sub>2</sub> ...	R <sub>N-2</sub>	R <sub>N-1</sub>	R <sub>N-1</sub>	-	-	-	-	-	-	-	-	-	-	-		
X	H to L	R <sub>1</sub>	R <sub>2</sub>	R <sub>3</sub> ...	R <sub>N-1</sub>	R <sub>N</sub>	R <sub>N</sub>	-	-	-	-	-	-	-	-	-	-	-		
-	-	X	X	X	...	X	X	L	R <sub>1</sub>	R <sub>2</sub>	R <sub>3</sub> ...	R <sub>N-1</sub>	R <sub>N</sub>	-	-	-	-	-		
-	-	P <sub>1</sub>	P <sub>2</sub>	P <sub>3</sub> ...	P <sub>N-1</sub>	P <sub>N</sub>	P <sub>N</sub>	H	P <sub>1</sub>	P <sub>2</sub>	P <sub>3</sub> ...	P <sub>N-1</sub>	P <sub>N</sub>	L	P <sub>1</sub>	P <sub>2</sub>	P <sub>3</sub> ...	P <sub>N-1</sub>	P <sub>N</sub>	
-	-	-	-	-	-	-	-	-	X	X	X	...	X	X	L	L	L	...	L	L

Note:

- L = Low logic level
- H = High logic level
- X = Irrelevant
- P = Present state
- R = Previous state

Timing Diagram

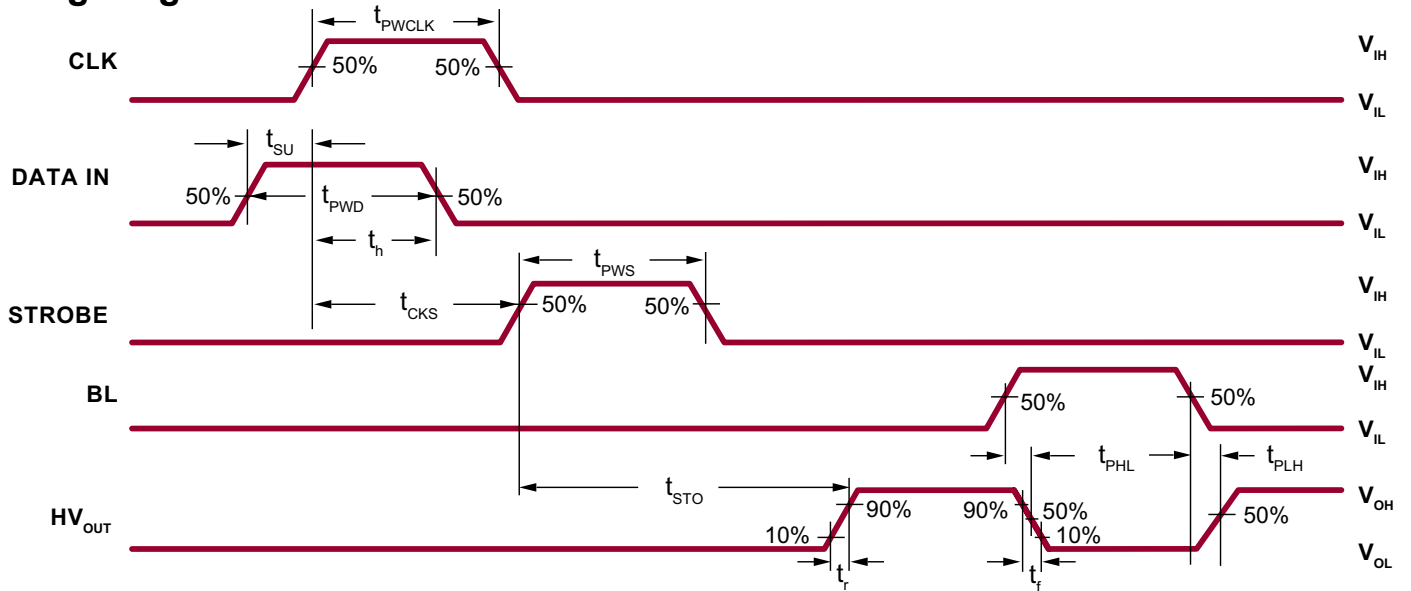

Input and Output Equivalent Circuits

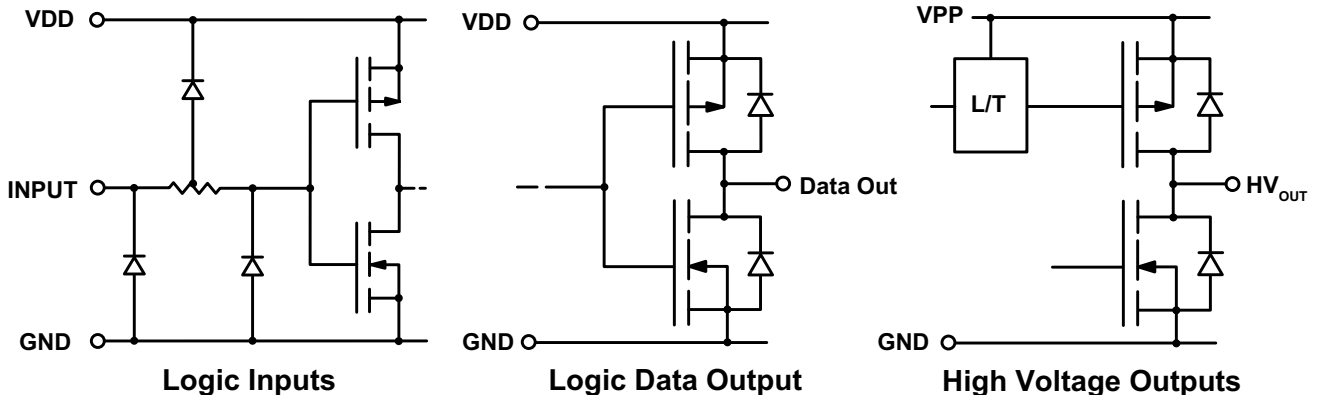

## 28-Lead PDIP Pin Description

Pin #	Function
1	VPP
2	Data Out
3	HV <sub>OUT</sub> 20
4	HV <sub>OUT</sub> 19
5	HV <sub>OUT</sub> 18
6	HV <sub>OUT</sub> 17
7	HV <sub>OUT</sub> 16
8	HV <sub>OUT</sub> 15
9	HV <sub>OUT</sub> 14
10	HV <sub>OUT</sub> 13

Pin #	Function
11	HV <sub>OUT</sub> 12
12	HV <sub>OUT</sub> 11
13	BLANKING
14	GND
15	CLOCK
16	STROBE
17	HV <sub>OUT</sub> 10
18	HV <sub>OUT</sub> 9
19	HV <sub>OUT</sub> 8
20	HV <sub>OUT</sub> 7

Pin #	Function
21	HV <sub>OUT</sub> 6
22	HV <sub>OUT</sub> 5
23	HV <sub>OUT</sub> 4
24	HV <sub>OUT</sub> 3
25	HV <sub>OUT</sub> 2
26	HV <sub>OUT</sub> 1
27	Data In
28	VDD

## 28-Lead PLCC Pin Description

Pin #	Function
1	VPP
2	Data Out
3	HV <sub>OUT</sub> 20
4	HV <sub>OUT</sub> 19
5	HV <sub>OUT</sub> 18
6	HV <sub>OUT</sub> 17
7	HV <sub>OUT</sub> 16
8	HV <sub>OUT</sub> 15
9	HV <sub>OUT</sub> 14
10	HV <sub>OUT</sub> 13

Pin #	Function
11	HV <sub>OUT</sub> 12
12	HV <sub>OUT</sub> 11
13	BLANKING
14	GND
15	CLOCK
16	STROBE
17	HV <sub>OUT</sub> 10
18	HV <sub>OUT</sub> 9
19	HV <sub>OUT</sub> 8
20	HV <sub>OUT</sub> 7

Pin #	Function
21	HV <sub>OUT</sub> 6
22	HV <sub>OUT</sub> 5
23	HV <sub>OUT</sub> 4
24	HV <sub>OUT</sub> 3
25	HV <sub>OUT</sub> 2
26	HV <sub>OUT</sub> 1
27	Data In
28	VDD

## 28-Lead SOW Pin Description

Pin #	Function
1	VPP
2	Data Out
3	HV <sub>OUT</sub> 20
4	HV <sub>OUT</sub> 19
5	HV <sub>OUT</sub> 18
6	HV <sub>OUT</sub> 17
7	HV <sub>OUT</sub> 16
8	HV <sub>OUT</sub> 15
9	HV <sub>OUT</sub> 14
10	HV <sub>OUT</sub> 13

Pin #	Function
11	HV <sub>OUT</sub> 12
12	HV <sub>OUT</sub> 11
13	BLANKING
14	GND
15	CLOCK
16	STROBE
17	HV <sub>OUT</sub> 10
18	HV <sub>OUT</sub> 9
19	HV <sub>OUT</sub> 8
20	HV <sub>OUT</sub> 7

Pin #	Function
21	HV <sub>OUT</sub> 6
22	HV <sub>OUT</sub> 5
23	HV <sub>OUT</sub> 4
24	HV <sub>OUT</sub> 3
25	HV <sub>OUT</sub> 2
26	HV <sub>OUT</sub> 1
27	Data In
28	VDD

# 28-Lead PDIP (.600in Row Spacing) Package Outline (P)

1.565x.580in body, .250in height (max), .100in pitch

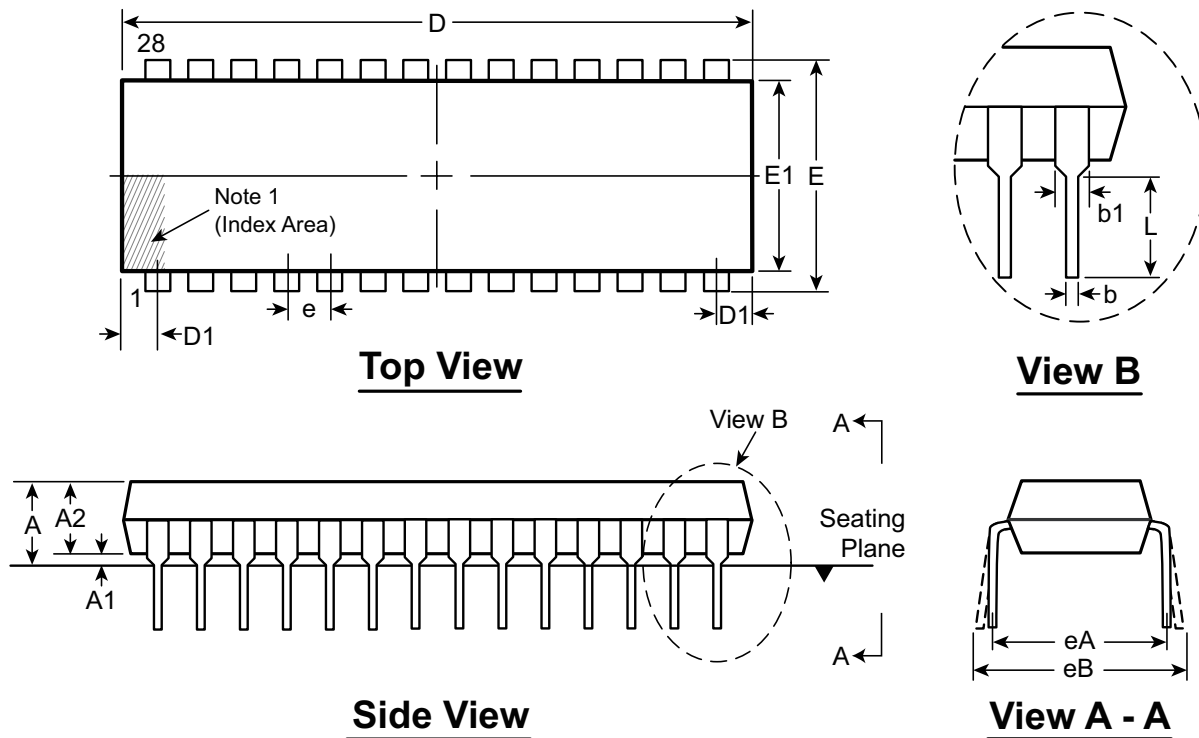

**Note:**  
 1. A Pin 1 identifier must be located in the index area indicated. The Pin 1 identifier can be: a molded mark/identifier; an embedded metal marker; or a printed indicator.

Symbol	A	A1	A2	b	b1	D	D1	E	E1	e	eA	eB	L		
Dimension (inches)	MIN	.140*	.015	.125	.014	.030	1.380	.065 <sup>†</sup>	.590 <sup>†</sup>	.485	.100 BSC	.600 BSC	.600*	.115	
	NOM	-	-	-	-	-	-	-	-	-			-	-	-
	MAX	.250	.055*	.195	.023 <sup>†</sup>	.070	1.565	.085*	.625	.580			.700	.200	

JEDEC Registration MS-011, Variation AB, Issue B, June, 1988.

\* This dimension is not specified in the JEDEC drawing.

† This dimension differs from the JEDEC drawing.

Drawings not to scale.

Supertex Doc. #: DSPD-28DIPP, Version B041009.

# 28-Lead PLCC Package Outline (PJ)

**.453x.453in. body, .180in. height (max), .050in. pitch**

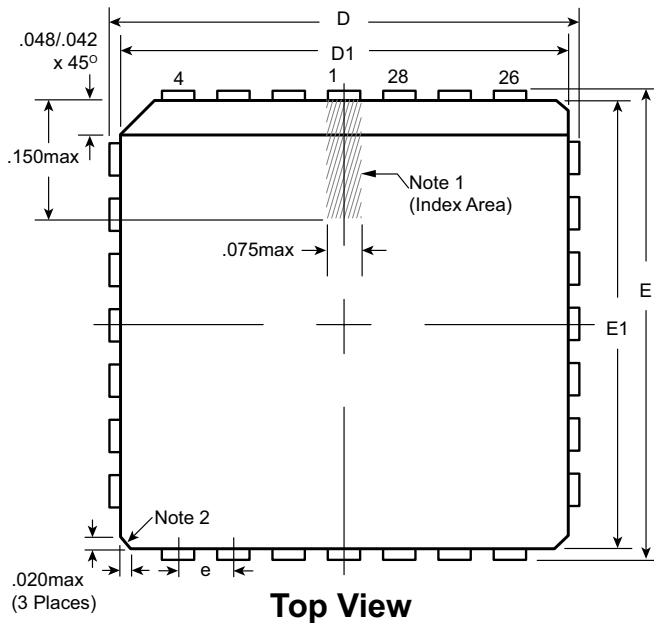

**Top View**

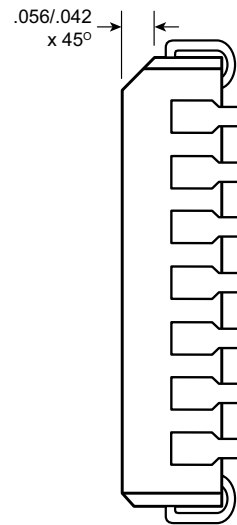

**Vertical Side View**

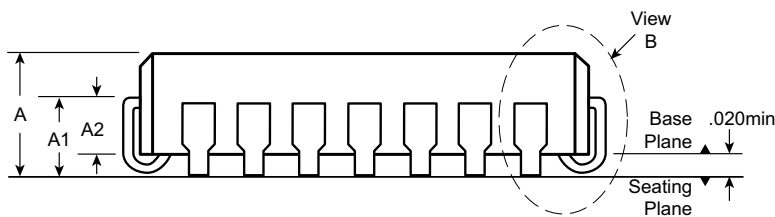

**Horizontal Side View**

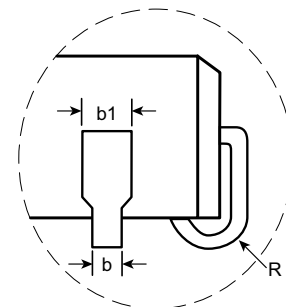

**View B**

**Notes:**

1. A Pin 1 identifier must be located in the index area indicated. The Pin 1 identifier can be: a molded mark/identifier; an embedded metal marker; or a printed indicator.
2. Actual shape of this feature may vary.

Symbol		A	A1	A2	b	b1	D	D1	E	E1	e	R
Dimension (inches)	MIN	.165	.090	.062	.013	.026	.485	.450	.485	.450	.050 BSC	.025
	NOM	.172	.105	-	-	-	.490	.453	.490	.453		.035
	MAX	.180	.120	.083	.021	.032	.495	.456	.495	.456		.045

JEDEC Registration MS-018, Variation AB, Issue A, June, 1993.

Drawings not to scale.

Supertex Doc. #: DSPD-28PLCCPJ, Version B031111.

# 28-Lead SOW (Wide Body) Package Outline (WG)

17.90x7.50mm body, 2.65mm height (max), 1.27mm pitch

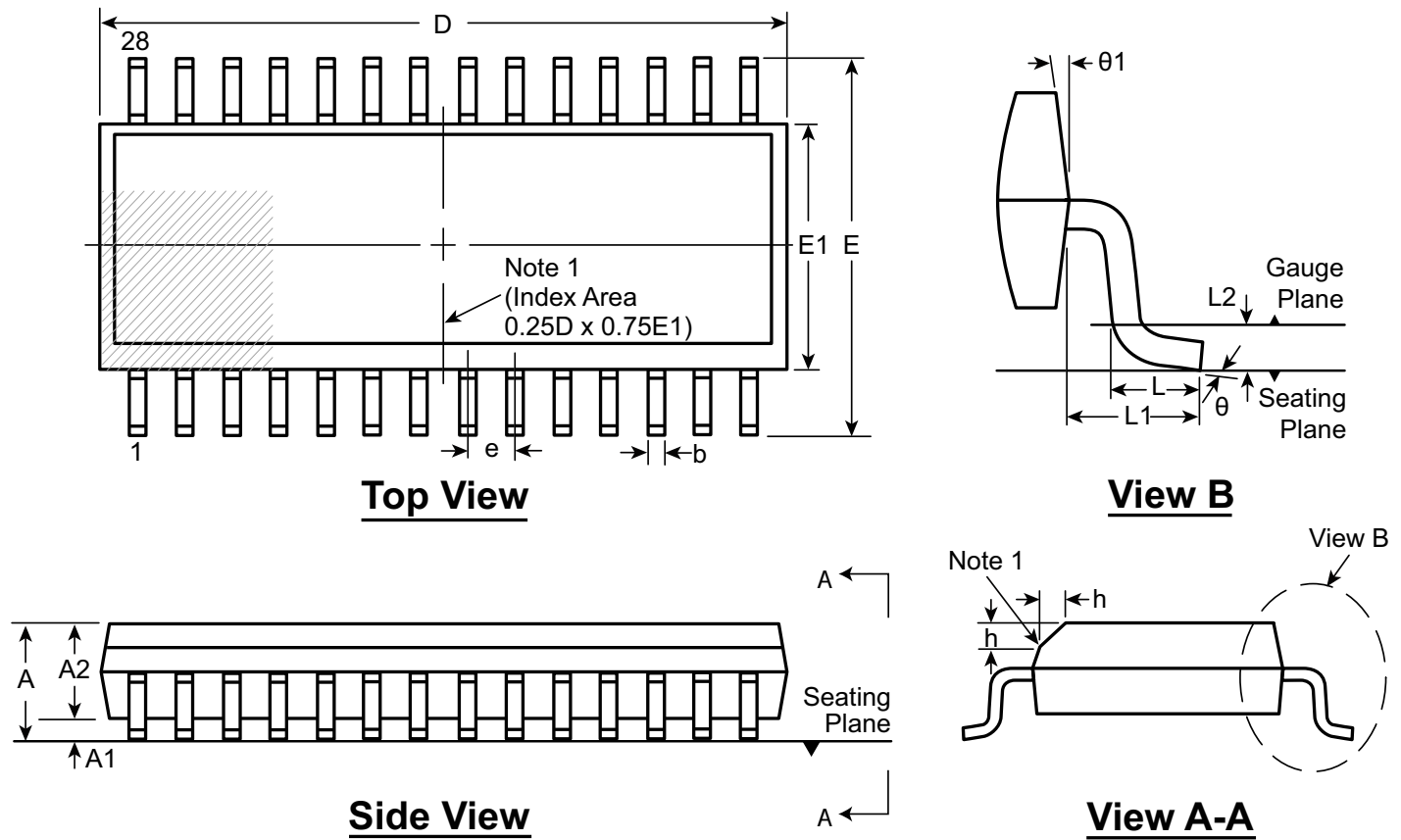

**Note:**  
 1. A Pin 1 identifier must be located in the index area indicated. The Pin 1 identifier can be: a molded mark/identifier; an embedded metal marker; or a printed indicator.

Symbol	A	A1	A2	b	D	E	E1	e	h	L	L1	L2	θ	θ1	
Dimension (mm)	MIN	2.15*	0.10	2.05	0.31	17.70*	9.97*	7.40*	1.27 BSC	0.25	0.40	1.40 REF	0.25 BSC	0°	5°
	NOM	-	-	-	-	17.90	10.30	7.50		-	-			-	-
	MAX	2.65	0.30	2.55*	0.51	18.10*	10.63*	7.60*		0.75	1.27			8°	15°

JEDEC Registration MS-013, Variation AE, Issue E, Sep. 2005.

\* This dimension is not specified in the JEDEC drawing.

Drawings are not to scale.

Supertex Doc. #: DSPD-28SOWWG, Version D041309.

(The package drawing(s) in this data sheet may not reflect the most current specifications. For the latest package outline information go to: <http://www.supertex.com/packaging.html>.)

**Supertex inc.** does not recommend the use of its products in life support applications, and will not knowingly sell them for use in such applications unless it receives an adequate "product liability indemnification insurance agreement." **Supertex inc.** does not assume responsibility for use of devices described, and limits its liability to the replacement of the devices determined defective due to workmanship. No responsibility is assumed for possible omissions and inaccuracies. Circuitry and specifications are subject to change without notice. For the latest product specifications refer to the **Supertex inc.** (website: <http://www.supertex.com>)