

Operation of a Trisil™ crowbar type protection diode

Introduction

In the field of parallel protection, the devices used have two main functions in transient operation.

- Limit the voltage.
- Divert the surge current.

If the first function is carried out perfectly by an avalanche junction, confirmed by the success of the Transil™ series, the second is limited by voltage permanently present across the diode terminals.

Use of increasingly sophisticated but fragile electronic components and publication of new standards do not allow the use of Transil diodes in certain applications. This problem is solved by the use of a semiconductor device with two conducting states such as the thyristor (or Triac in the bidirectional version).

STMicroelectronics has developed this type of component under the trade name of Trisil. This Application note describes the operation of the Trisil.

Figure 1. I / V characteristic of a Trisil

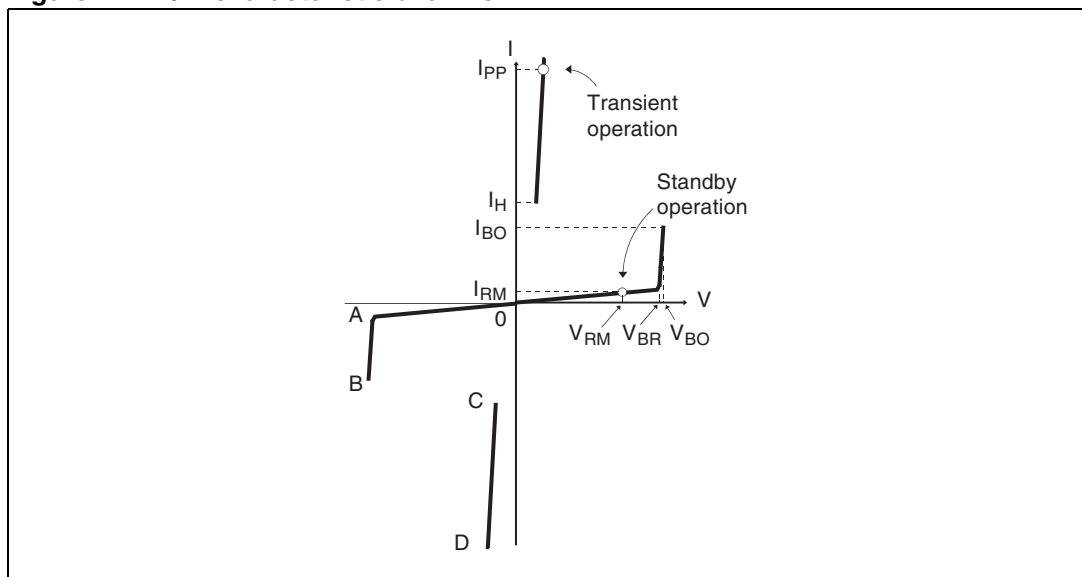

TM: Trisil is a trademark of STMicroelectronics
TM: Transil is a trademark of STMicroelectronics

1 Trisil characteristics

1.1 Electrical characteristic

The electrical characteristic of the Trisil is similar to that of a Triac (see [Figure 1](#)) except that the component has only two terminals.

Triggering in this case is not done via a gate but by an internal mechanism dependent on the current flowing through it.

1.2 Operation seen from the outside

In normal operation, the Trisil is biased at a voltage lower than or equal to the standby voltage (V_{RM}). At that point of the characteristic, the leakage current is about 10 nA and the presence of the Trisil connected across the equipment to be protected does not disturb its operation (see [Figure 2](#)).

The characteristic data at this point includes:

- Leakage current
- Electrical capacity
- Reliability of the component in blocking mode

Figure 2. Stand by characteristics

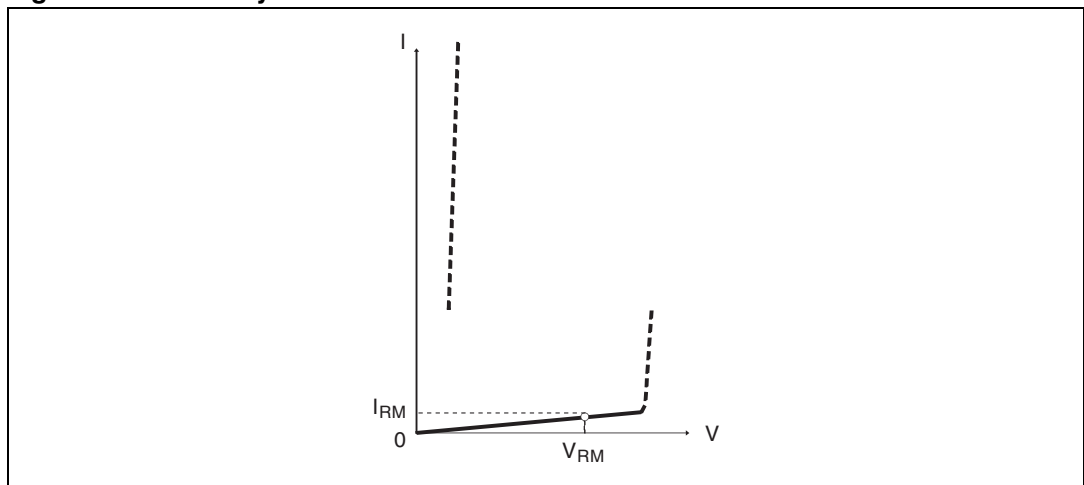

As the voltage increases beyond V_{BR} , the Trisil impedance drops from practically infinite to a few ohms. The Trisil remains biased at its avalanche voltage and its operation is then identical to that of a Transil diode (see [Figure 3](#)).

The characteristic parameters at this level are the limiting voltage (breakover voltage of the component, V_{BO}) and the time for switching between the blocked and conducting states.

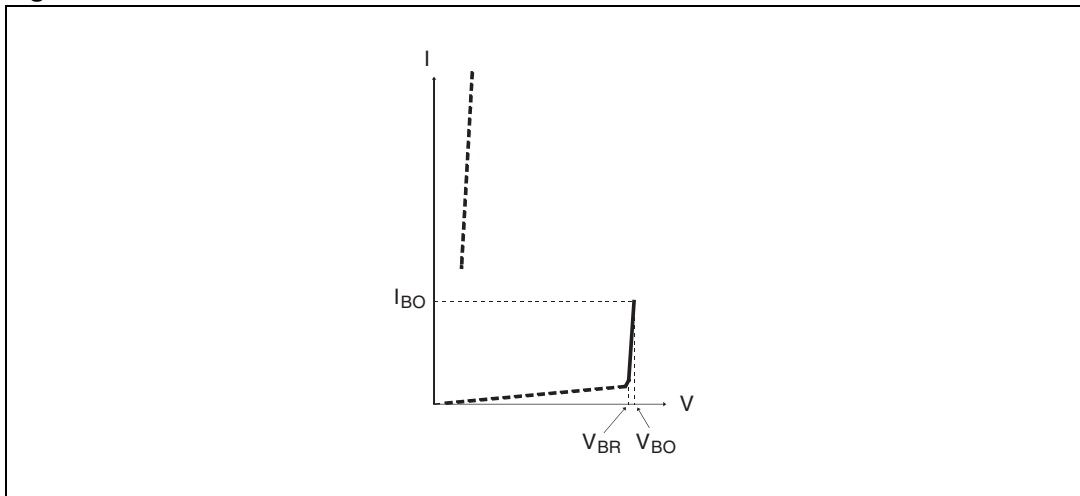
Figure 3. Avalanche characteristic of the Trisil

For current values higher than I_{BO} , the voltage across the Trisil drops to a few volts and the high currents permitted without damage are possible due to the low value of this voltage, since the physical limit is dependent on the dissipated power (see [Figure 4](#)).

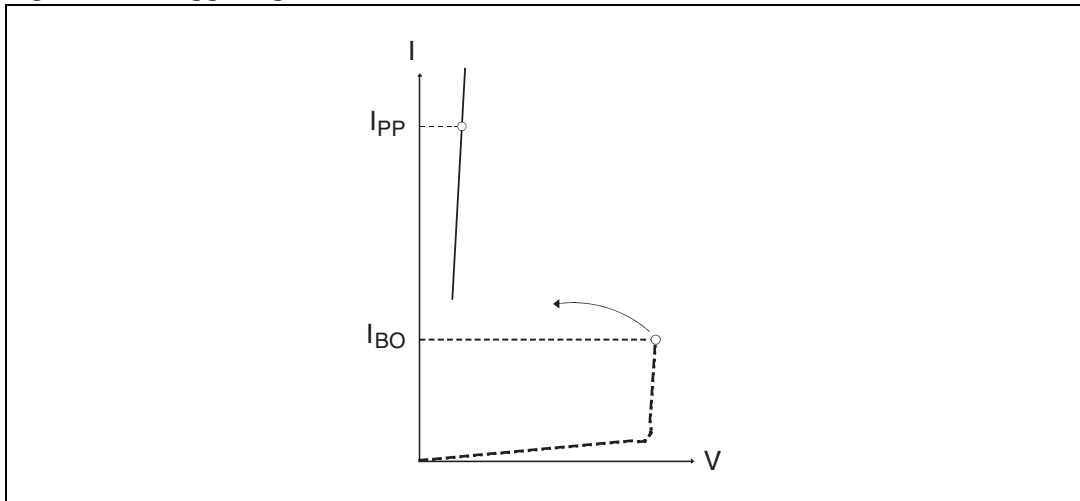
Figure 4. Triggering, and on-state characteristics

The characteristic parameter is then the possibility of withstanding surge currents (peak-point current, I_{PP}).

Return to standby operation by turning off the Trisil takes place when the current flowing through it drops below I_H . This is the characteristic parameter for switching from the conducting to the blocked state (see [Figure 5](#)).

Figure 5. Return to standby operation

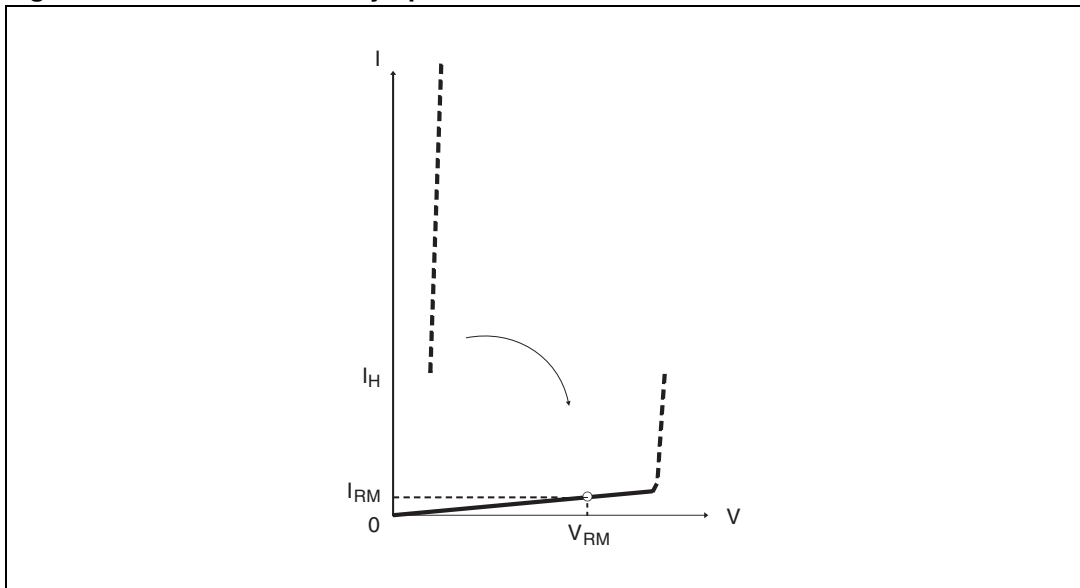

The surge current associated with the disturbance is diverted through the Trisil as soon as it begins to operate in the avalanche mode (see [Figure 3](#)) and the voltage limitation results from the electrical characteristic at this point. The behavior of the Trisil is here identical to that of the Transil. The difference depends on the level of the breakover current, I_{BO} , where the triggering of the thyristor structures take place.

This phenomenon results in absolute limitation independently of the current level, and a capacity to divert currents much higher than those possible for an avalanche diode (Transil). Furthermore, this limitation is independent of the avalanche voltage of the device.

1.3 Limiting property

Because of its operating mode, the Trisil results in absolute voltage limitation, independently of the surge current level, [Figure 6](#) and of the slope of the applied voltage ramp (see [Figure 7](#)).

Figure 6. Correlation between the voltage and the surge current

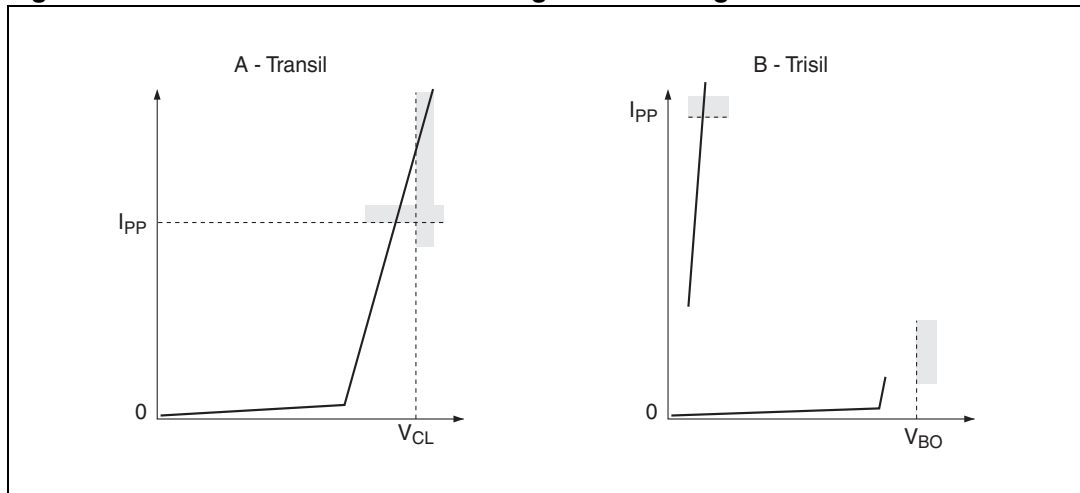
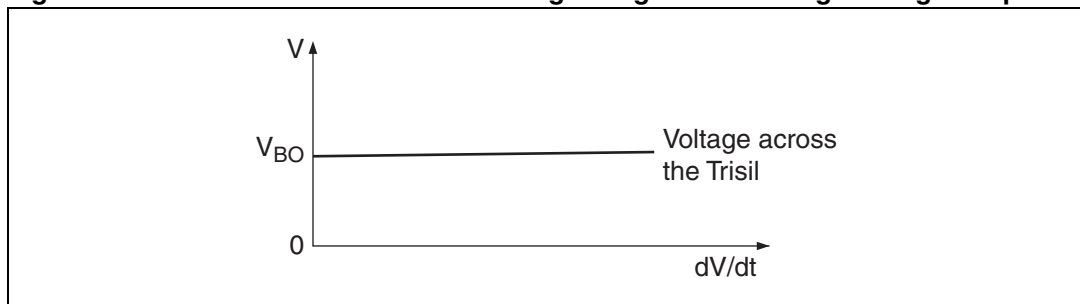

Figure 7. Correlation between the limiting voltage and the surge voltage ramp



In particular, if the surge current is higher than the guaranteed value in the catalogue, without however exceeding the physical limits of the component, the voltage across a Transil could reach the critical value destroying the equipment to be protected. For a Trisil, this risk is excluded.

Finally, for a surge current much higher than the guaranteed value, destruction of the Trisil always results in a short-circuit thus providing absolute protection for the equipment located downstream.

1.4 Behavior in case of current surges

The ability of semiconductor components to withstand high currents in transient operation is limited for pulses longer than 10 ns by a second breakdown due to heat. This phenomenon, although not destructive, is considered as the normal utilization limit in so far as the behavior of the component depends on the external circuit.

The temperature rise within the semiconductor is thus the parameter which defines the behavior of the component and its capacity to withstand current surges. It is given by [Equation 1](#):

Equation 1:

$$T_j = T_A + Z_{TH} V_{ON} \times I_{RS}$$

With

- T_j : instant temperature at the junction level
- T_A : ambient temperature
- Z_{TH} : transient thermal impedance (as a function of the duration of the pulse)
- V_{ON} : voltage across the terminals of the component in the conducting state
- I_{RS} : transient current flowing through the component

This equation clearly shows the advantage of the Trisil. A decrease in the voltage across its terminals enables it to conduct a much higher current than the avalanche diode for the same junction temperature. Since the voltage to be taken into consideration for the calculation is that in the conducting state, the permitted current levels in transient operation are independent of the avalanche voltage and the guaranteed values are identical for all the types of a given series (see [Figure 8](#)).

Figure 8. Comparison of the limited transient currents for a Transil and a Trisil in the similar cases (SMB).

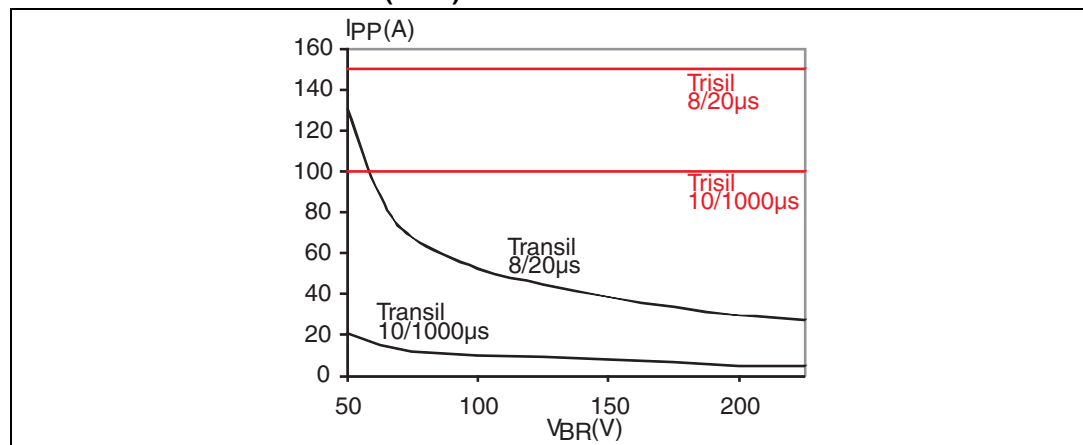

The maximum junction temperature taken into account in transient operation is not that given in the catalogues (junction temperature in operation or in storage) but corresponds, with a certain safety margin, to the second breakdown due to thermal causes, i.e. about 350-400 °C.

This high current capacity can be applied in AC operation at the 50 Hz industrial frequency (see [Figure 9](#)), which is particularly interesting in telephony where equipment should be protected against overvoltages resulting from accidental coupling of the telephone line with

the power distribution network. This type of protection is required by certain standards used in telecommunications.

Figure 9. Long duration overload test

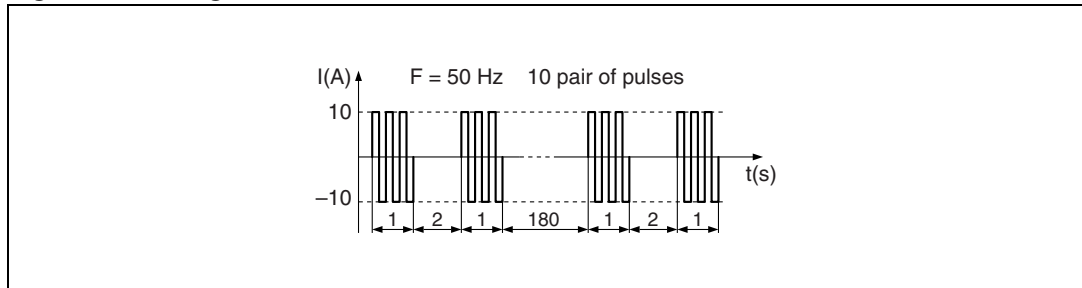

1.5 Response time

The response time of the component is the time it requires to limit the voltage. From this point of view the Trisil has exactly the same behavior as a Transil. The time is that required to switch from the standby operating point to the avalanche voltage. This is almost instantaneous.

This time should not be confused with that required to pass from the breakover point (V_{BO}) to the conducting characteristic. This time is longer but does not influence the limiting capability of the device.

1.6 Operation within the avalanche area

This section concerns the segment $V_{BR} - V_{BO}$ (see [Figure 3](#)) of the Trisil characteristic between the blocked state and the conducting state at low V_{ON} .

This portion of the characteristic is identical to that of an avalanche diode. Thus within this area, DC, AC or pulse-type operations are permitted. The currents are limited depending on the possibilities of junction-ambient air heat dissipation. The maximum current is defined by the following:

Equation 2:

$$T_j = T_A + R_{TH} V_{BO} I_{MAX} \leq T_{jMAX} = 150 \text{ } ^\circ\text{C}$$

The condition when the Trisil is not triggered is defined as follows:

Equation 3:

$$I_{MAX} < I_{BO}$$

The main differences from [Equation 1](#) are:

- Maximum junction temperature which is now that given by the catalogue, i.e. 150 °C
- Voltage which is that of the avalanche mechanism
- Continuous thermal resistance replacing the transient thermal impedance

In AC operation, although [Equation 2](#) still holds good, the voltage-current diagram as a function of time shown in [Figure 10](#) is clearer.

The value of the breakover current (I_{BO}) plays an important part in the capacity of the device in avalanche operation. If this value is high (see [Figure 11A](#)), the current in the component must be limited by a suitable series resistor. For lower values, avalanche operation takes place without destruction whatever the external circuit.

Figure 10. AC operation in the avalanche mode

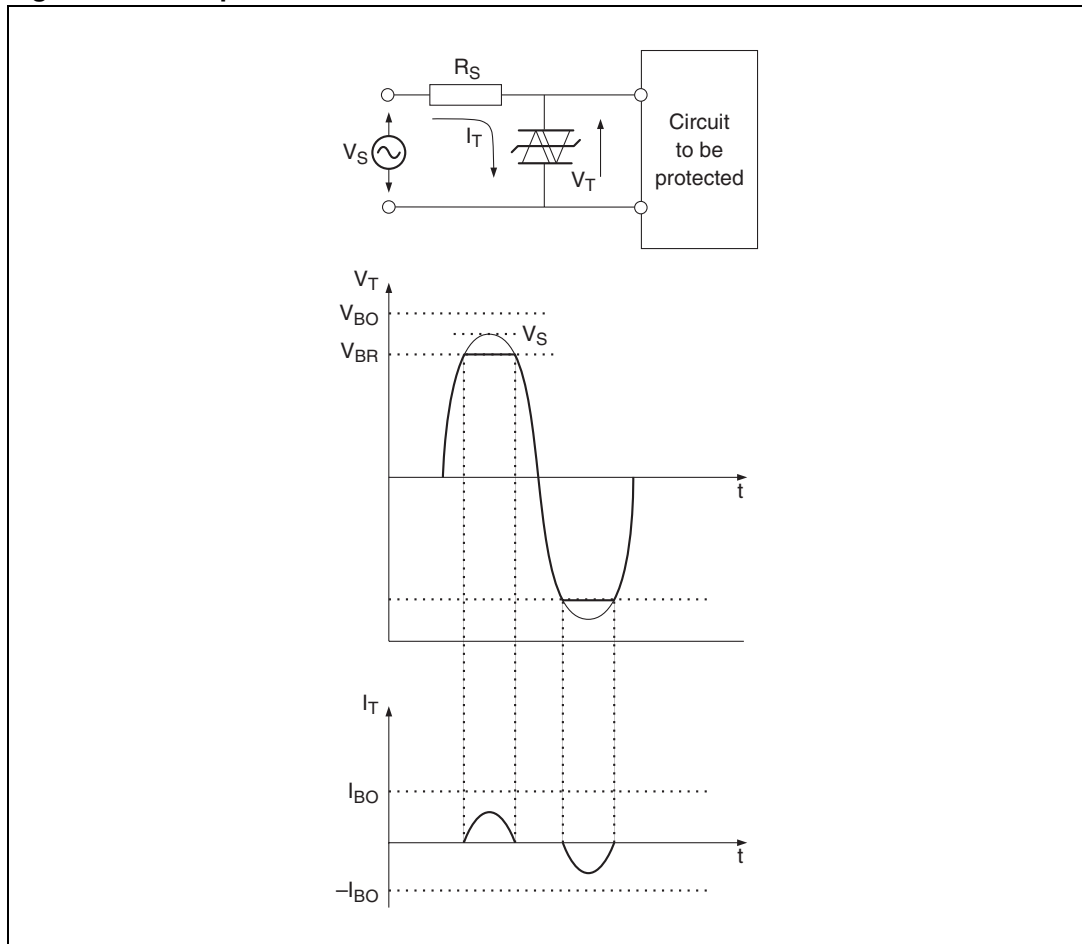
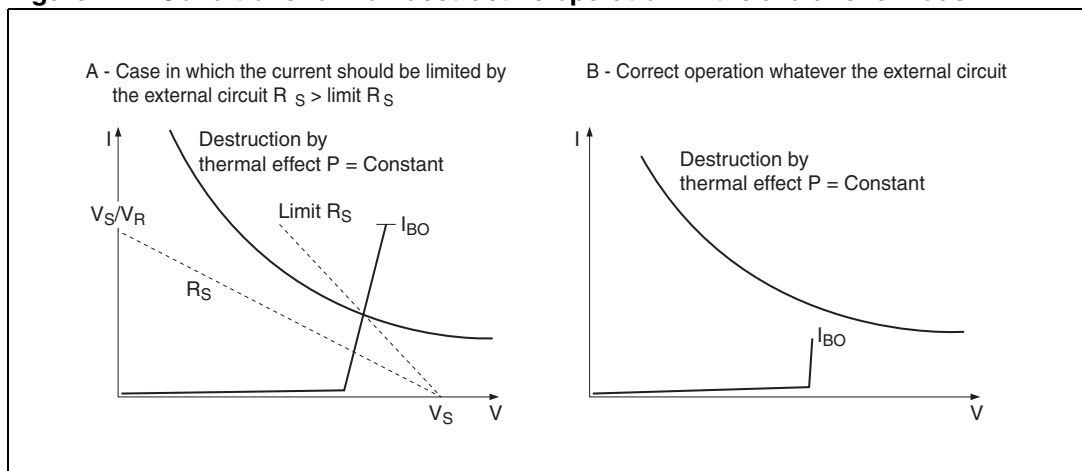

Figure 11. Conditions for non destructive operation in the avalanche mode



2 Physical operation

A Trisil consists of two thyristors connected back to back. It will suffice to explain the operation of one thyristor. The other operates in the same way if the voltage across the component is reversed.

Figure 12. Operation in the blocked mode

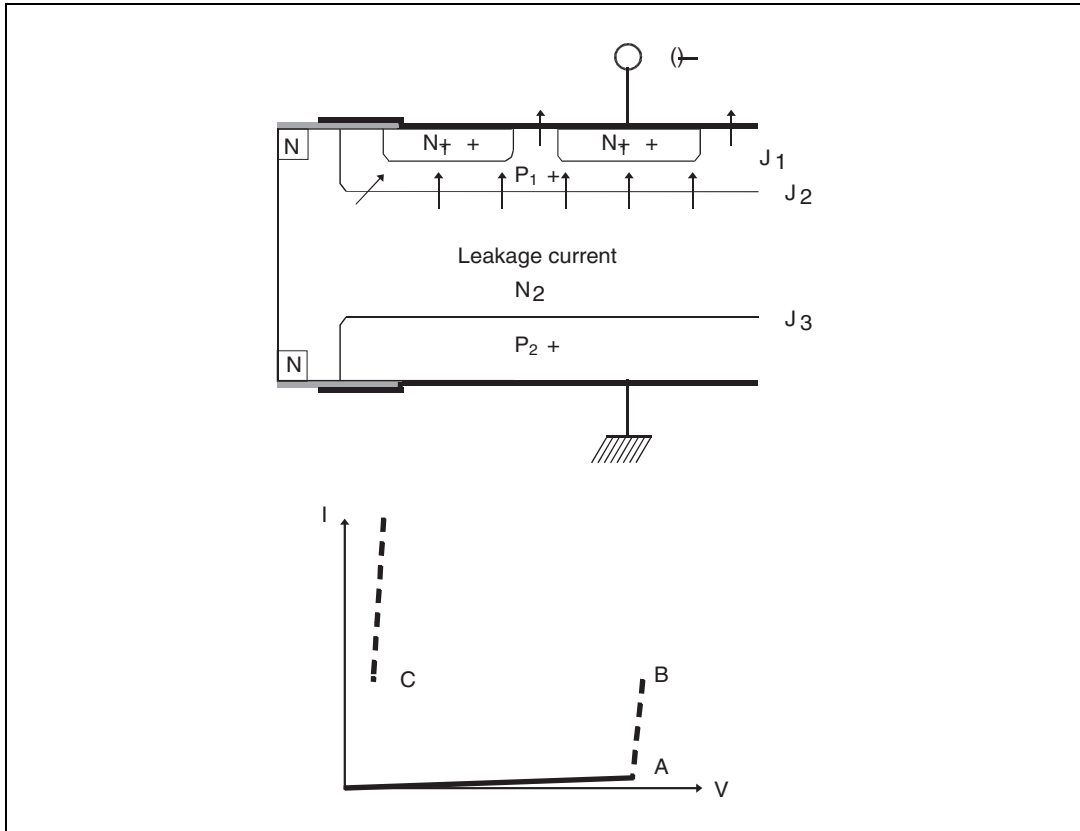
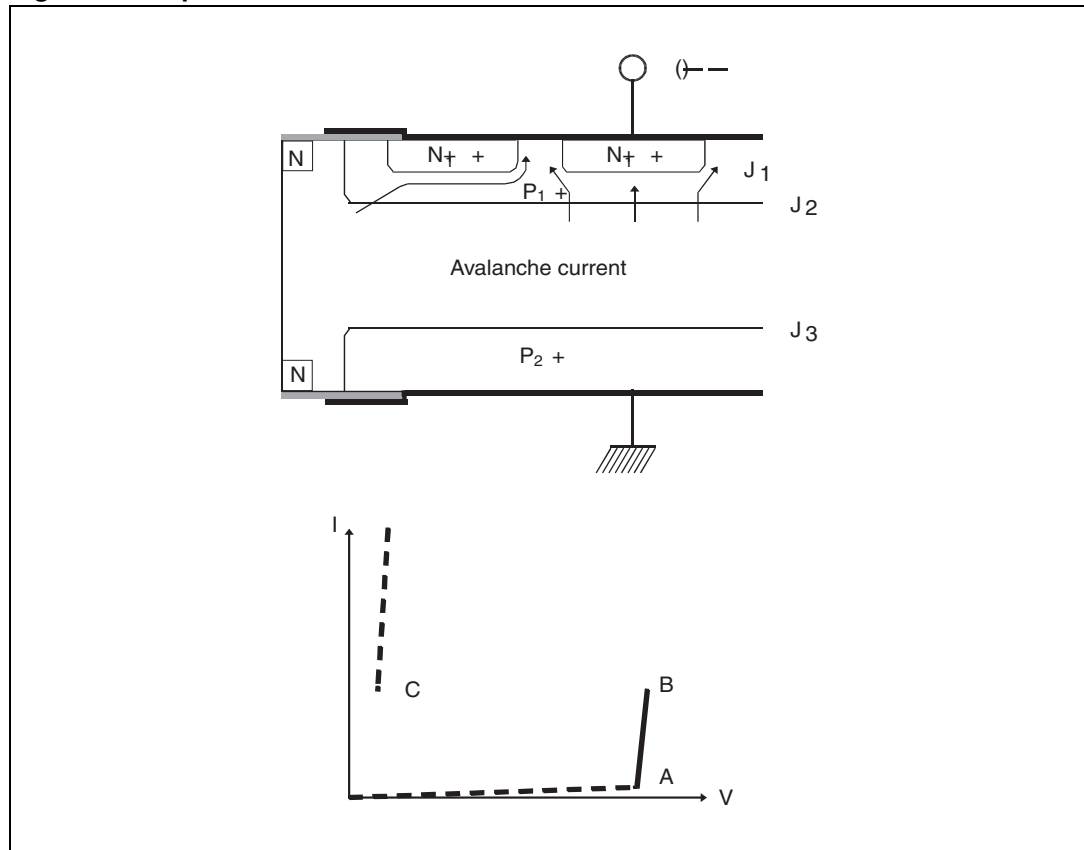
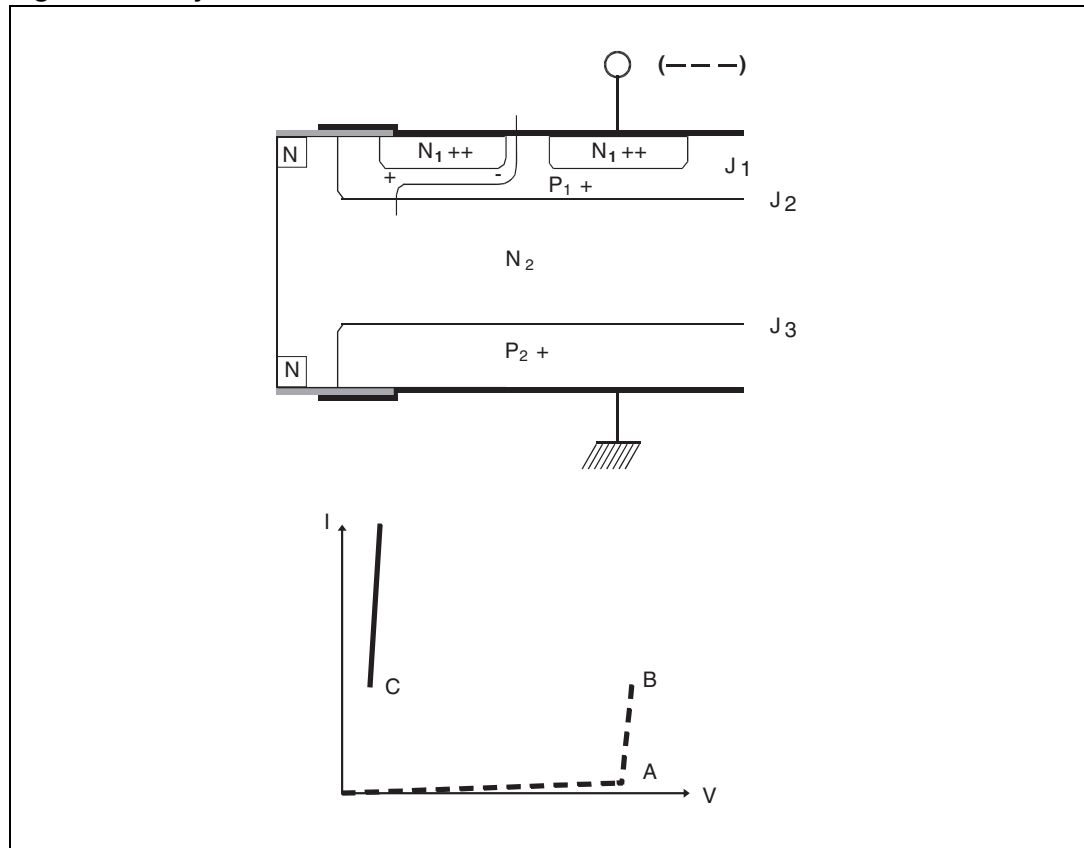

Figure 13. Operation in the avalanche mode



Application of a negative voltage on cathode N++ results in forward biasing of junctions J₁ and J₃ and reverse biasing of J₂. The current observed is thus the leakage current of junction J₂. When the voltage exceeds a certain value, junction J₂, which is reverse biased, begins to operate in the avalanche mode. The structure up to this current level operates like a diode (junction J₂). The side current biases the P₁ layer next to the N₁ part of the emitter. The highly doped N₁ layer has the same potential. The P₁ area at the surface is forced to the same potential as the N₁ region by metallization.

Figure 14. Thyristor effect of the Trisil



As the avalanche current increases, this difference of potential can reach the threshold of 0.6 V, a value which is sufficient to create injection of electrons from the cathode towards the P_1 area and thus trigger thyristor $N_1 P_1 N_2 P_2$.

The electrons thus injected into P_1 in fact will reach J_2 by diffusion, and cross it under the effect of the electrical field operating in the space charge of the reverse biased J_2 junction.

In N_2 , the electrons help to reduce the potential of this area compared with P_2 and as a result inject holes from P_2 towards N_2 . These holes travel in the reverse direction because of their polarity. When they arrive at P_2 they help to increase the potential of P_1 with respect to N_1 , this time resulting in the injection of electrons from N_1 to P_1 .

The procedure is cumulative. The excess electrons in N_2 and the holes in P_1 will compensate the fixed charges of the space charge and will thus suppress it. Junction J_2 will act as a forward biased junction and the voltage across the component will drop.

3 Revision history

Table 1. Document revision history

Date	Revision	Changes
February-1998	1	First issue.
10-May-2004	2	Stylesheet update. No content change.
05-Jul-2010	3	Updated trademark statements.

Please Read Carefully:

Information in this document is provided solely in connection with ST products. STMicroelectronics NV and its subsidiaries ("ST") reserve the right to make changes, corrections, modifications or improvements, to this document, and the products and services described herein at any time, without notice.

All ST products are sold pursuant to ST's terms and conditions of sale.

Purchasers are solely responsible for the choice, selection and use of the ST products and services described herein, and ST assumes no liability whatsoever relating to the choice, selection or use of the ST products and services described herein.

No license, express or implied, by estoppel or otherwise, to any intellectual property rights is granted under this document. If any part of this document refers to any third party products or services it shall not be deemed a license grant by ST for the use of such third party products or services, or any intellectual property contained therein or considered as a warranty covering the use in any manner whatsoever of such third party products or services or any intellectual property contained therein.

UNLESS OTHERWISE SET FORTH IN ST'S TERMS AND CONDITIONS OF SALE ST DISCLAIMS ANY EXPRESS OR IMPLIED WARRANTY WITH RESPECT TO THE USE AND/OR SALE OF ST PRODUCTS INCLUDING WITHOUT LIMITATION IMPLIED WARRANTIES OF MERCHANTABILITY, FITNESS FOR A PARTICULAR PURPOSE (AND THEIR EQUIVALENTS UNDER THE LAWS OF ANY JURISDICTION), OR INFRINGEMENT OF ANY PATENT, COPYRIGHT OR OTHER INTELLECTUAL PROPERTY RIGHT.

UNLESS EXPRESSLY APPROVED IN WRITING BY AN AUTHORIZED ST REPRESENTATIVE, ST PRODUCTS ARE NOT RECOMMENDED, AUTHORIZED OR WARRANTED FOR USE IN MILITARY, AIR CRAFT, SPACE, LIFE SAVING, OR LIFE SUSTAINING APPLICATIONS, NOR IN PRODUCTS OR SYSTEMS WHERE FAILURE OR MALFUNCTION MAY RESULT IN PERSONAL INJURY, DEATH, OR SEVERE PROPERTY OR ENVIRONMENTAL DAMAGE. ST PRODUCTS WHICH ARE NOT SPECIFIED AS "AUTOMOTIVE GRADE" MAY ONLY BE USED IN AUTOMOTIVE APPLICATIONS AT USER'S OWN RISK.

Resale of ST products with provisions different from the statements and/or technical features set forth in this document shall immediately void any warranty granted by ST for the ST product or service described herein and shall not create or extend in any manner whatsoever, any liability of ST.

ST and the ST logo are trademarks or registered trademarks of ST in various countries.

Information in this document supersedes and replaces all information previously supplied.

The ST logo is a registered trademark of STMicroelectronics. All other names are the property of their respective owners.

© 2010 STMicroelectronics - All rights reserved

STMicroelectronics group of companies

Australia - Belgium - Brazil - Canada - China - Czech Republic - Finland - France - Germany - Hong Kong - India - Israel - Italy - Japan - Malaysia - Malta - Morocco - Philippines - Singapore - Spain - Sweden - Switzerland - United Kingdom - United States of America

www.st.com