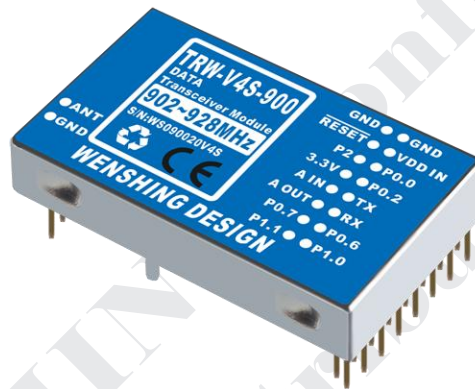

---

 900MHz Frequency-Hopping Spread Spectrum RF Module
 

---

**Version History**

Version	Date	Changes
V1.00	May 21, 2009	1 <sup>st</sup> . Edition
V1.01	Sep 4, 2009	2 <sup>nd</sup> . Edition
V1.02	Jan 6, 2010	3 <sup>rd</sup> . Edition

## Application

- UHF Wireless Data Transceiver
- Exclusive Hopping Technology
- UART interface operation easily
- AMR: Automatic Meter Reading
- RKE: Two-way Remote Keyless Entry
- Wireless RS232
- VOIP Phone
- Wireless Game Pad
- Home Automation
- Remote Control

## Key Feature

- Exclusive Hopping Technology
- RF Output Power up to 50mW
- Sensitivity up to -118dBm
- Low Power Consumption
- Voltage Supply 4.5V to 9V
- UART interface operation easily
- Transceiver Data Rate 1.6Kbps~128Kbps

## Characteristic

Parameter	Min	Type	Max	Unit	Condition
<b>Operating Condition</b>					
Operating temperature range	-20		+70	°C	
Operating supply voltage	4.5	5	9	V	
<b>Current Consumption</b>					
Rx mode		30		mA	
Tx mode			75	mA	Vcc 5V
<b>RF Characteristic</b>					
Frequency range	902		928	MHz	
Data rate	1.6		128	Kbps	GFSK
Tx Output power	0		27	dBm	
Rx sensitivity			-118	dBm	
Modulation		GFSK			
<b>Other</b>					
ESD			500	V	

## Block Diagram

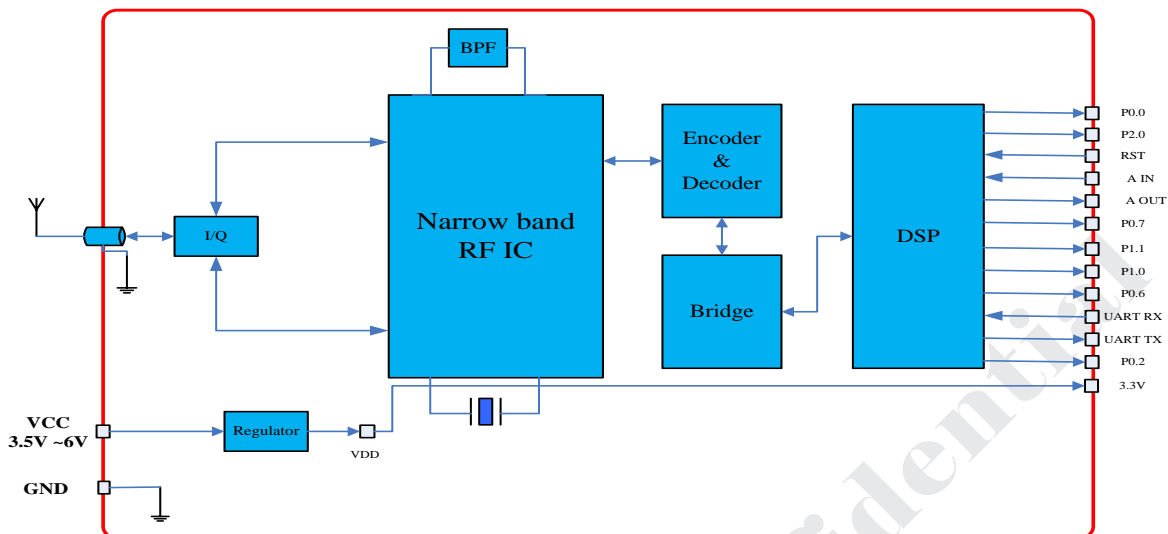

## View

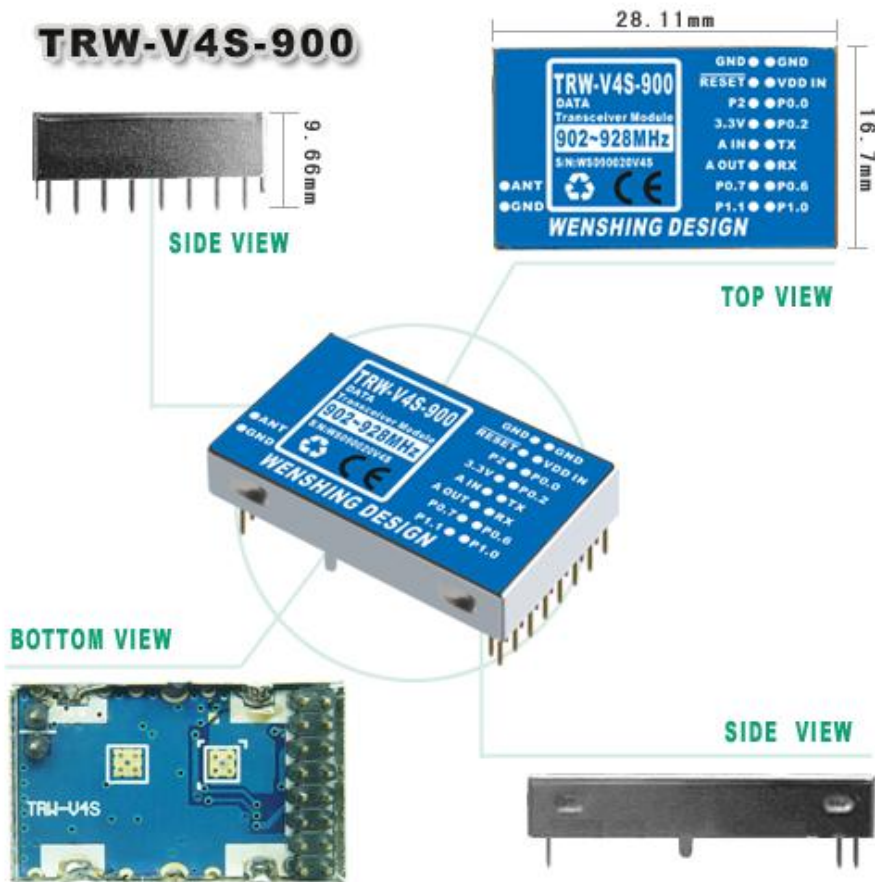

## Pin Assignment

Pin	Function	I/O	Description
1	ANT	ANT	Antenna Interface
2	GND	P	Power Negative
3	GND	P	Power Negative
4	REST	I	Low action
5	P2.0	I	1-External Trigger (with WS-MRDD)
6	3.3V OUT	P	Internal Power Output
7	A IN	O	Clear to send-CTS
8	A OUT	O	External PA Power control
9	P0.7	O	If receive the data this pin will puller-low
10	P1.1	O	GPIO_2
11	P1.0	O	If send the data this pin will puller-high
12	P0.6	O	Data set ready-DTR
13	RX	I	RF Serial Data Input ( SPI I )
14	TX	O	RF Serial Data Output ( SPI O )
15	P0.2	I	Request to send-RTS
16	P0.0	I	2-External Trigger (with WS-MRDD)
17	VDD IN	P	Power Cathode
18	GND	P	Power Negative

# Application Circuit

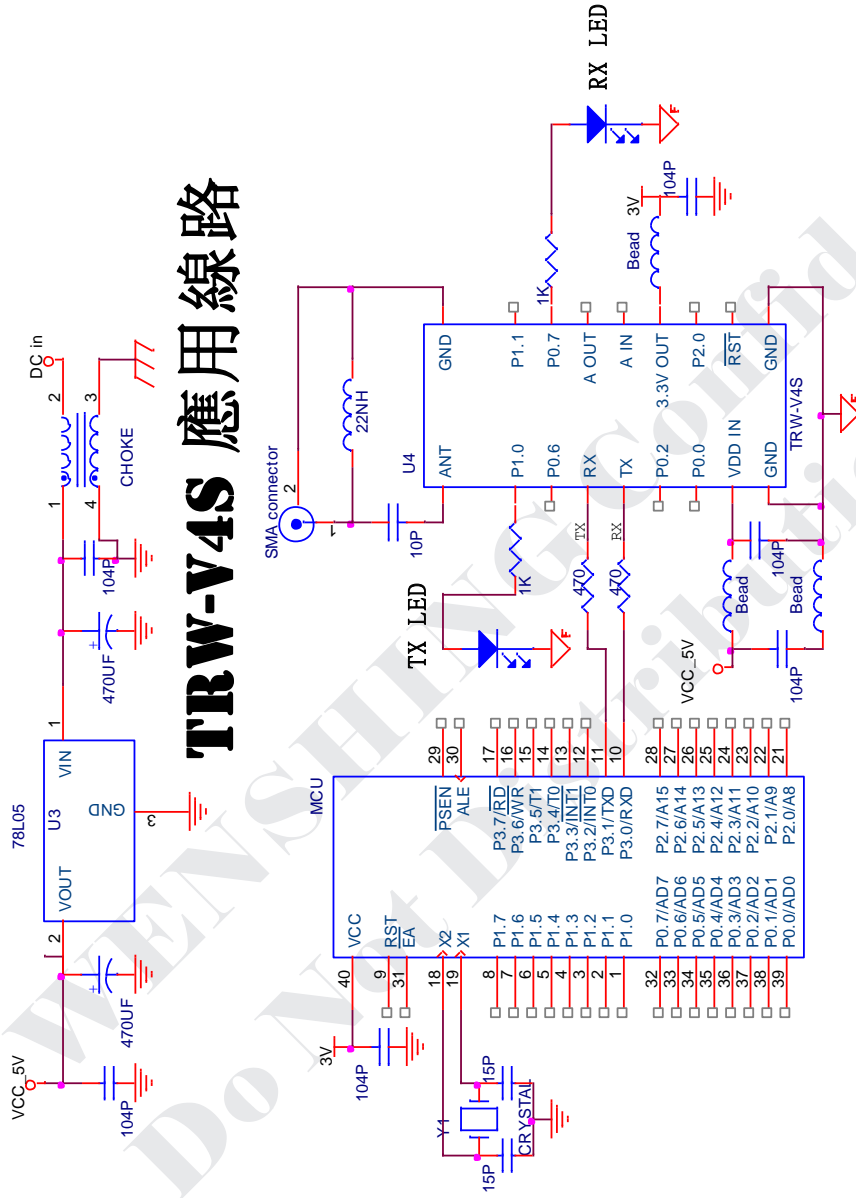

## TRW-V4S 應用線路

本線路圖受著作權保護，非經書面授權，不得翻閱，複印，抄襲，公開場合傳閱，否則受公訴，民事責任及公司法

Title		WenShing V4S 應用線路
Size	Document Number	Rev
	Custom	A
Date:	Friday, September 04, 2009	Sheet 1 of 1

## Command Summary

Command	Send Value	Back Value	Remark
0x80 (Product info)	0x80	TRWV4S-V100	
0x81 (Set RF transmission rate)	0x81+1 byte (0x00~07)	Correct setting will return send value; incorrect setting will have no back value.	1 byte setting, default value is 0x03
0x83 (Set ID)	0x83+1 byte (0x00~FF)	Correct setting will return send value; incorrect setting will have no back value.	1 byte setting, default value is 0x00
0x85 (Set RS232 rate)	0x85+1 byte (0x00~07)	Correct setting will return send value; incorrect setting will have no back value.	1 byte setting, default value is 0x07=115200bps
0x86 (Set link mode)	0x86+1 byte (0x00 or 0x01)	Correct setting will return send value; incorrect setting will have no back value.	1 byte setting, default value is 0x01=RS232 Modem
0x87 (Set group ID)	0x87+2 bytes (0x0000~FFFF)	Correct setting will return send value; incorrect setting will have no back value.	2 bytes setting default value is 0x0000
0x8D (Detect interface rate)	0x8D+72 bytes (Only 0x8D)	Correct setting will return send value; incorrect setting will have no back value.	Repeat 0x8D, total are 72 bytes, repeat sending and switch interface rate until it return send value.
0x8F (Cancel transfer station)	0x8F+72 bytes (Only 0x8F)	Correct setting will return send value; incorrect setting will have no back value.	Repeat 0x8F, total are 72 bytes, if you received return send value after you sent value, it is meaning you already cancel transfer station.
0xC0 (Preset transfer station)	0xC0+1 ~ 11 bytes (0x00 ~ FF)	Correct setting will return send value; incorrect setting will have no back value.	Min: 1 byte Max: 10 bytes

### 🔴 Point-to-Point Transmission

This mode can be used in multi-point transmission. You can specify receive side ID when you send data. It can receive data when GID and UID of your equipment can meet using conditions and under effective signal cover range. If you want to specify transmission path (maximum is 10 transfer stations), please add Address and receive side ID before every information, but the data which you send every time must be less than 64 bytes (it must include Address and ID of receive side). If you set preset transfer station, you can't use point-to-point transmission; you need to cancel transfer station so that you can use point-to-point transmission.

Address	ID Byte
0x71~7B	1~11
0x71=1 send 1 receive ; 0x72=1 send 1 transfer 1 receive ; 0x73=1 send 2 transfer and 1 receive	Path order

### 🔴 Preset set process of Point-to-Point Transmission mode

When you use point-to-point transmission mode, please set corresponding parameters so that it can start to work. Please set according to following steps.  
Set RF transmission rate → Set equipment UID → Set TRW-V4S interface rate → Set group ID → Finish setting

1. Set RF transmission rate: suggest you collocate with interface rate to set when you start to set. Usually, RF transmission rate must be bigger than interface rate to avoid error data.
2. Set equipment ID: UID is for identity between equipments. User can specify point-to-point path through point-to-point transmission.
3. Set TRW-V4S interface rate: you can collocate with equipment rate.
4. Set group ID: GID is for working group identify. When GID are different, equipments can't send data or receive data each other.

### 🔴 Example

- If you want to send data 9999 from equipment which UID=01 to equipment which UID=02, data format which you send is 0x71029999

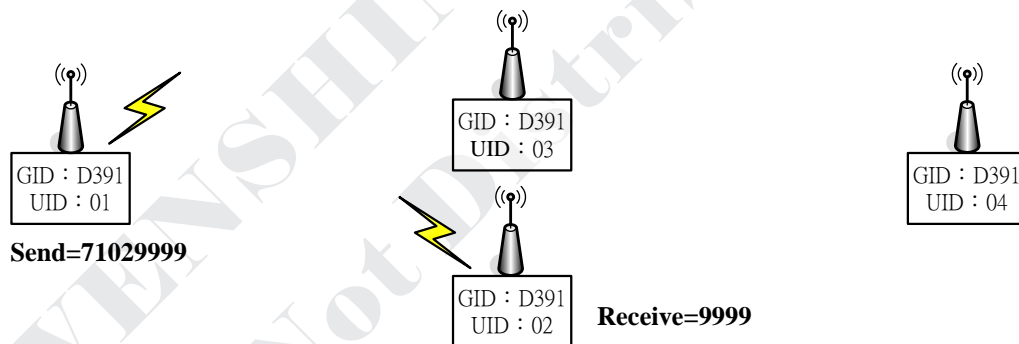

- If you want to send data 9999 from equipment which UID=01 to equipment which UID=03, data format which you send is 0x71039999.

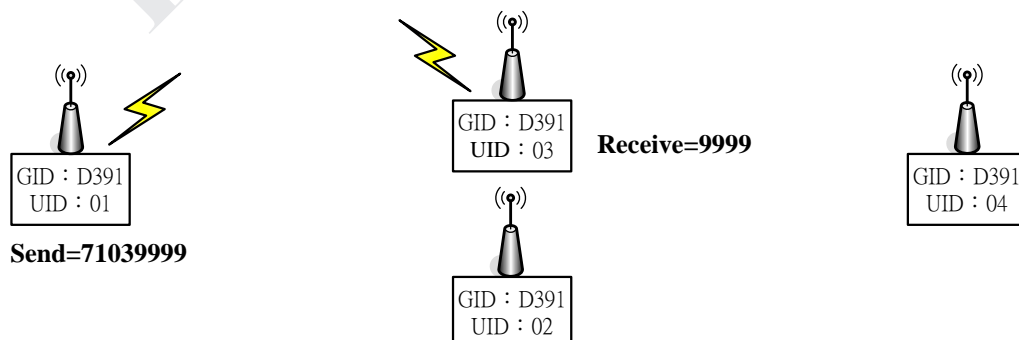

- If you want to send data 9999 from equipment which UID=01 through equipment which UID=03 to transfer to equipment which UID=04, data format which you send is 0x7203049999.

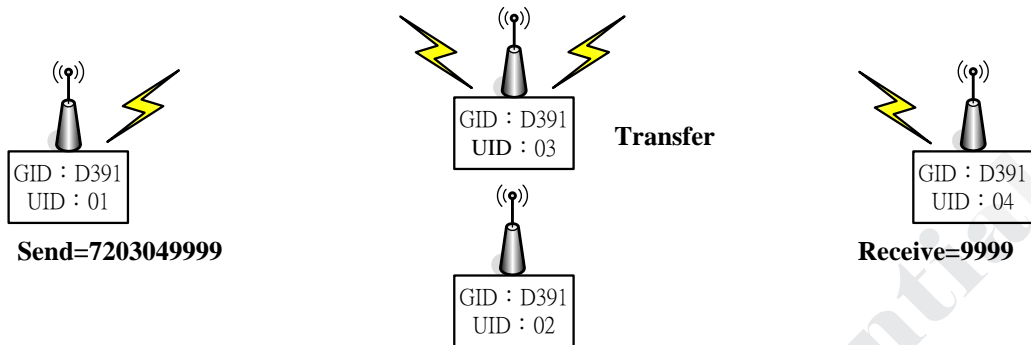

- If you want to send data 9999 from equipment which UID=01 through equipment which UID=03 to transfer to equipment which UID=04 and transfer again to equipment which UID=02, data format which you send is 0x730304029999.

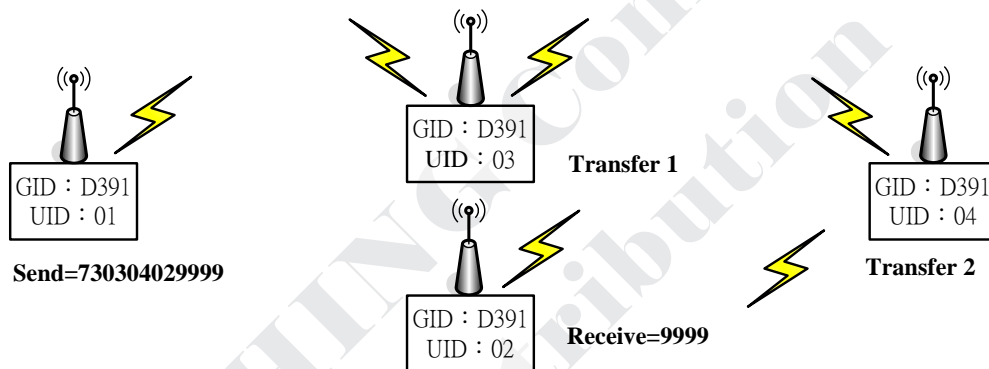

## Command Description

### 0 Product info

It will automatically reply product corresponding info after sent this command.

Address	Read/Write	Byte	Default
0x80	R	-	TRWV4S-V100

### 0 Set RF transmission rate

We suggest you to collocate with interface rate as setting when you set wireless transmission rate. Normal setting, RF transmission rate must be bigger than interface rate to avoid error data.

Address	Read/Write	Byte	Default(Hex)	Range(Hex)				
0x81	W	1	07	00 ~ 07				
Rate (bps)	1600	3200	6400	12800	25600	51200	76800	128000
Code	0x00	0x01	0x02	0x03	0x04	0x05	0x06	0x07



Address	Read/Write	Byte	Default(Hex)	Range(Hex)
0x83	W	1	00	00 ~ FF

### Example

User just needs to send data from equipment which UID=01 to equipment which UID=04, it will receive data when UID=04.

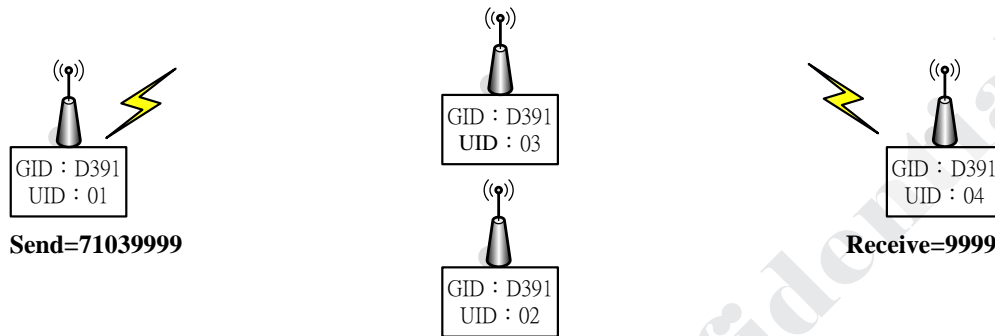

### Set interface rate

1200bps~115200bps; user can amend interface rate according to different application, default value is 115200bps.

Address	Read/Write	Byte	Default(Hex)	Range(Hex)
0x85	W	1	07	00 ~ 07

Rate (bps)	1200	2400	4800	9600	19200	38400	57600	115200
Code	0x00	0x01	0x02	0x03	0x04	0x05	0x06	0x07

### Set link mode

TRW-V4S-9 can collocate with RD-800HI and 3C Message Receive Device. User can amend the link mode through command according to the product which you allocate with.

Address	Read/Write	Byte	Default(Hex)	Range(Hex)
0x86	W	1	01	00 ~ 02

Value	3C Message Receive Device	TRW-V4S	RD-800HI
TRW-V4S	00	01	02

### Set group ID

GID is for working group identification. When GID is different, both equipments can not send or receive data each other.

Address	Read/Write	Byte	Default(Hex)	Range(Hex)
0x87	W	2	0000	0000 ~ FFFF

**Example**

When GID=1234 and transmitted side which UID=0A send data to receive side which UID=2A, GID=0000. But equipment which UID=2A can't receive any data, only GID=1234 can receive data from receive side which UID=2A.

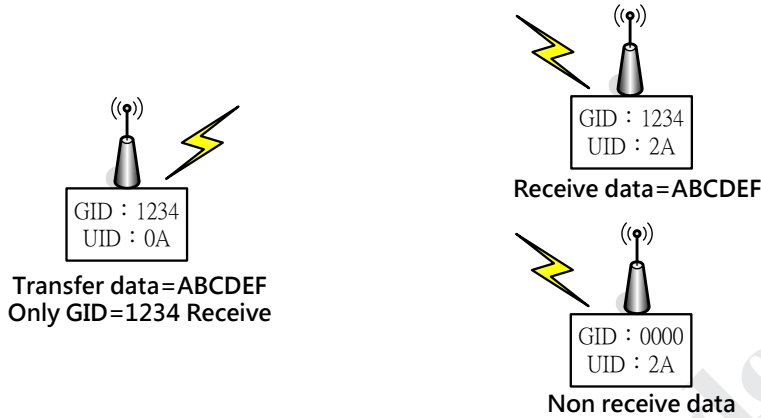

**Detect interface rate**

Please switch interface rate and input 72 bytes of 0X8D when you can't make sure the interface rate. Equipment side will return same 0x8D, total are 72 bytes when interface rate is correct.

Address	Read/Write	Byte	Default(Hex)	Range(Hex)
0x8D	R	72	-	8D8D8D ~ 8D

**Cancel transfer station**

Input 72 bytes of 0X8F for one time when you need to cancel transfer station. When receiver side returns same 0X8F, total are 72 bytes, it is meaning you cancel preset transfer station.

Address	Read/Write	Byte	Default(Hex)	Range(Hex)
0x8F	W	72	-	8F8F8F ~ 8F

**Preset transfer station**

This function needs to preset constant path of data transmission mode. After finish preset, every data doesn't need to add any command and path. Equipment will automatically transfer and send data according to preset path. Maximum transfer stations you can set are 10. Setting way is to add UID number on final receiver side behind the command. If you need to go through transfer station, you need to insert UID number of path in the middle.

Address	Read/Write	Byte	Default(Hex)	Range(Hex)
0xC0	W	1 ~ 11	-	00 ~ FF

**Example**

There are various path setting ways when user need to sent data from equipment which UID=01 to equipment which UID=04.

✧ Method 1:

Command is 0xC00304 when UID=01→UID=03→UID=04.

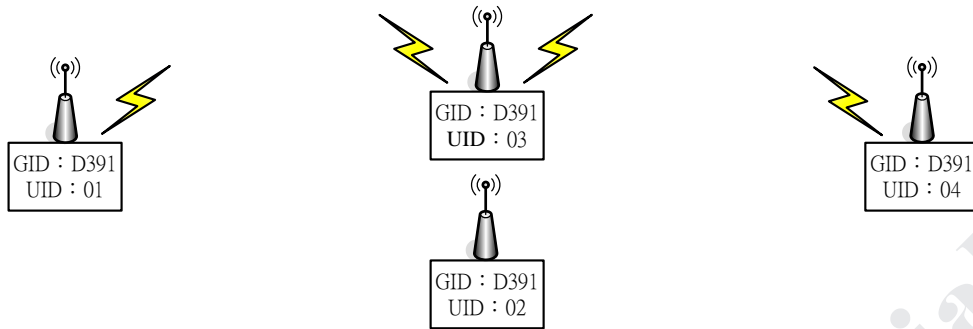

Or , command is 0xC00204 when UID=01→UID=02→UID=04.

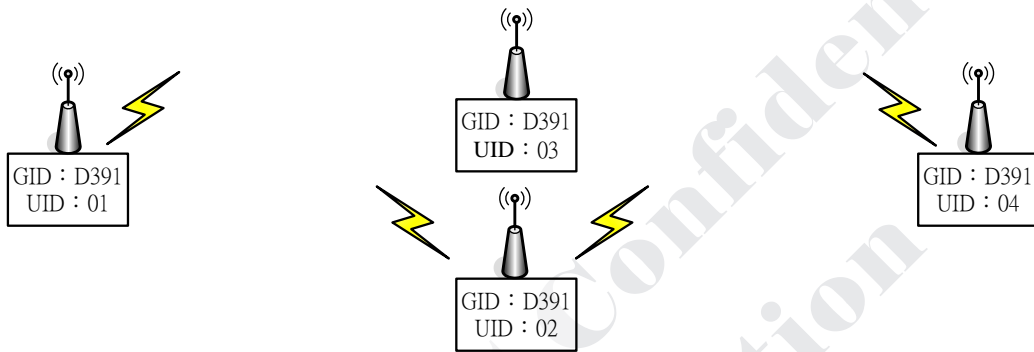

✧ Method 2:

Command is 0xC0020304 when UID=01→UID=02→UID=03→UID=04.

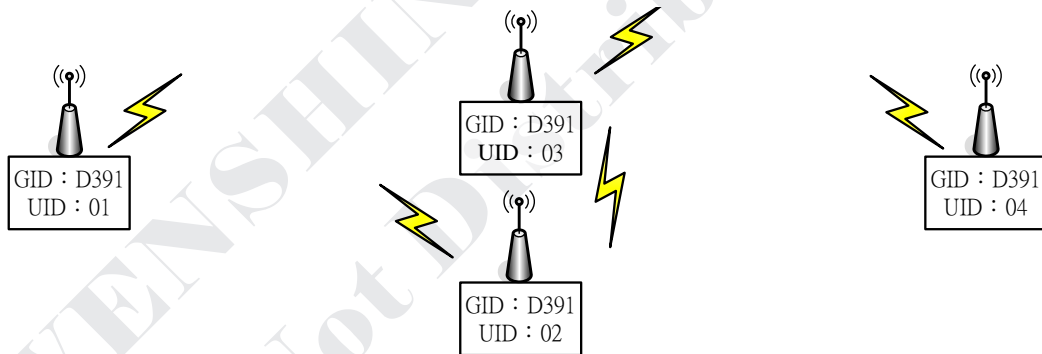

Or , command is 0xC0030204 when UID=01→UID=03→UID=02→UID=04.

