

925MHz Wireless RF Hi Power Transceiver Module

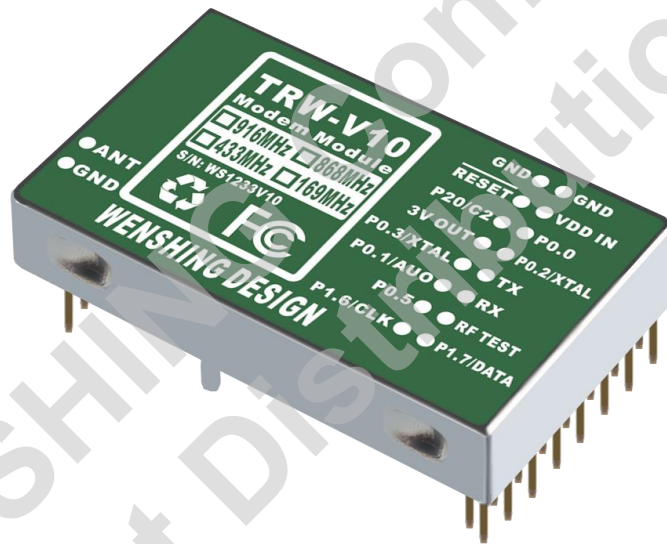

Version History

Version	Date	Changes
V1.0	June. 21, 2012	1 st . Edition

WENSHING **TRW-V10-925P** wireless high power transceiver RF module is designed, developed and manufactured as contemplated for general use, without limitation, ordinary industrial use, general office use, personal use, and household use, but is not designed, developed and manufactured as contemplated (1) For use accompanying fatal risks or dangers that, unless extremely high safety is secured, could have a serious effect to the public, and could lead directly to death, personal injury, severe physical damage or other loss (i.e., nuclear reaction control in nuclear facility, aircraft flight control, air traffic control, mass transport control, medical life support system, missile launch control in weapon system). (2) For use requiring extremely high reliability (i.e., submersible repeater and artificial satellite). You shall not use this product for the above-mentioned using. If your equipment is likely to be used for the above-mentioned uses, please consult with our sales representative before using. WENSHING Component Division shall not be liable against you and/or any third party for any claims or damages arising in connection with the above-mentioned uses of this product.

Frequency Band

Module No.	TRW-V10-169-X-X	TRW-V10-433-X-X	TRW-V10-868-X-X	TRW-V10-916-X-X
Frequency Range	163~175MHz	431~435MHz	860~870MHz	902~928MHz
Power Correspondence	TRW-V10-169-L-X	TRW-V10-433-L-X	TRW-V10-868-L-X	TRW-V10-916-L-X
	Output 50mW	Output 50mW	Output 50mW	Output 50mW
	TRW-V10-169-P-X	TRW-V10-433-P-X	TRW-V10-868-P-X	TRW-V10-916-P-X
	Output 500mW	Output 500mW	Output 500mW	Output 500mW
Optional	Module No. Description: If the last section of module No. is G, which means this module has G sensor If the last section of module No. is P, which means this module has Pressure sensor Every model of this module has TEMP sensor. All optional parts can be added to the module.			

Japan Frequency Band

Module No.	TRW-V10-426-X-X	TRW-V10-429-X-X	REMARK
Frequency Range	426.025MHz	429.25~429.7375MHz	(25KHz 間隔のみ)
Power Correspondence	1mW, 10mW	1mW, 10mW	動作コマンドで設定切替え
Optional	Module No. Description: If the last section of module No. is G, which means this module has G sensor If the last section of module No. is P, which means this module has Pressure sensor Every model of this module has TEMP sensor. All optional parts can be added to the module.		

Function Introduction

TRW-V10-925P is wireless high power data two-way transceiver RF module. The key feature of this module is its resilience against interference, which way surpass traditional wireless module. The build in Saw Filter can remove unnecessary interference signals. When the transmitting distance is not far enough during operational environment, relay protocol station can be used to forward signal; also, transmitting to other interface if it is required.

This module is fully digitalized structure designed, there is no adjustment required. This module includes UR and I2C interface, which provide convenience communication. Also, we can modify software, including special monitor point for voltage (A/D), current, output voltage (D/A) according to customer demand. End product requirement can be met without add MCU; this will save designing time for user.

Another key feature of TRW-V10-925P is its wide operating temperature, which is between -20°C~+70°C. The build-in AFC can auto-lock frequency, there is no need to worry about frequency shifting after long period of operation.

TRW-V10-925P has wide range of usage other than transmitting date. This module can vibration collector, (detecting landslides) and weather detection. Other function can be added accordingly; also, software can be changed, this module is convenient and easy to use.

Application

- Safety Monitoring System
- 900MHz Wireless Cordless
- Wireless Remote Control Car
- Wireless Remote Control Robot
- Meter, Water Meter, Coin Data Acquisition
- Wireless Modem
- Debris Flow Detection Point
- Weather Detection point
- Wireless Transmission network Transfer Function
- WSN

Electrical Specification

Parameter	Min	Type	Max	Unit	Condition
Operating Condition					
Operating Temperature Range	-20		+70	°C	
Operating Supply Voltage	4.5	5	5.5	V	
Current Consumption					
RX Mode (5Vdc)		30	35	mA	
TX Mode (5Vdc)			500	mA	Peak
RF Characteristic					
Frequency Range	902	916	928	MHz	
Data Rate	1.6		128	Kbps	GFSK
TX Output Power		27	27.5	dBm	
RX Sensitivity	-118	-120	-128	dBm	
Modulation		GFSK			
Other					
ESD			2000	V	
Interface Data Rate	1.2		115.2	Kbps	

Internal Block Diagram

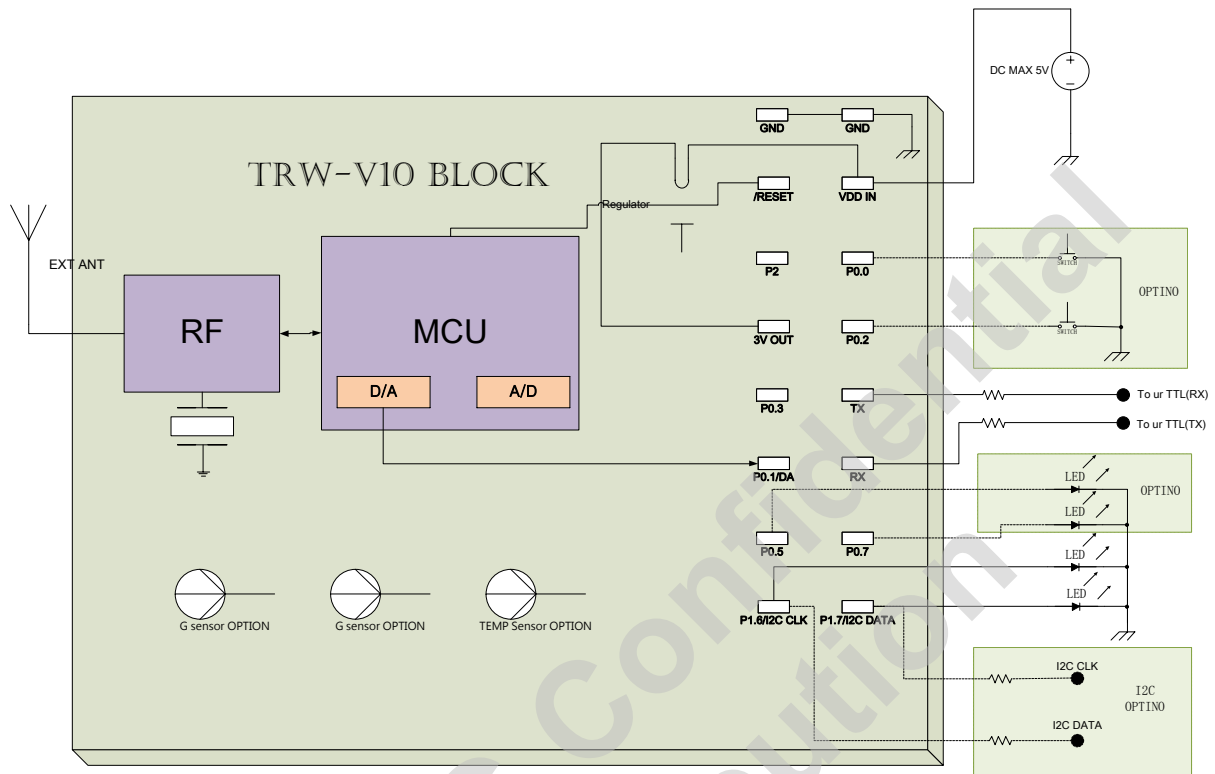

Absolute Maximum Rating

Minimum	Maximum	Units	Operating conditions
Supply voltages			
-0.3	5.5	V	VDD
	0	V	GND
Input voltage			
-0.3	3.6	V	VI (DATA IN)
Output voltage			
GND TO 3	GND TO 3	V	VO

Size

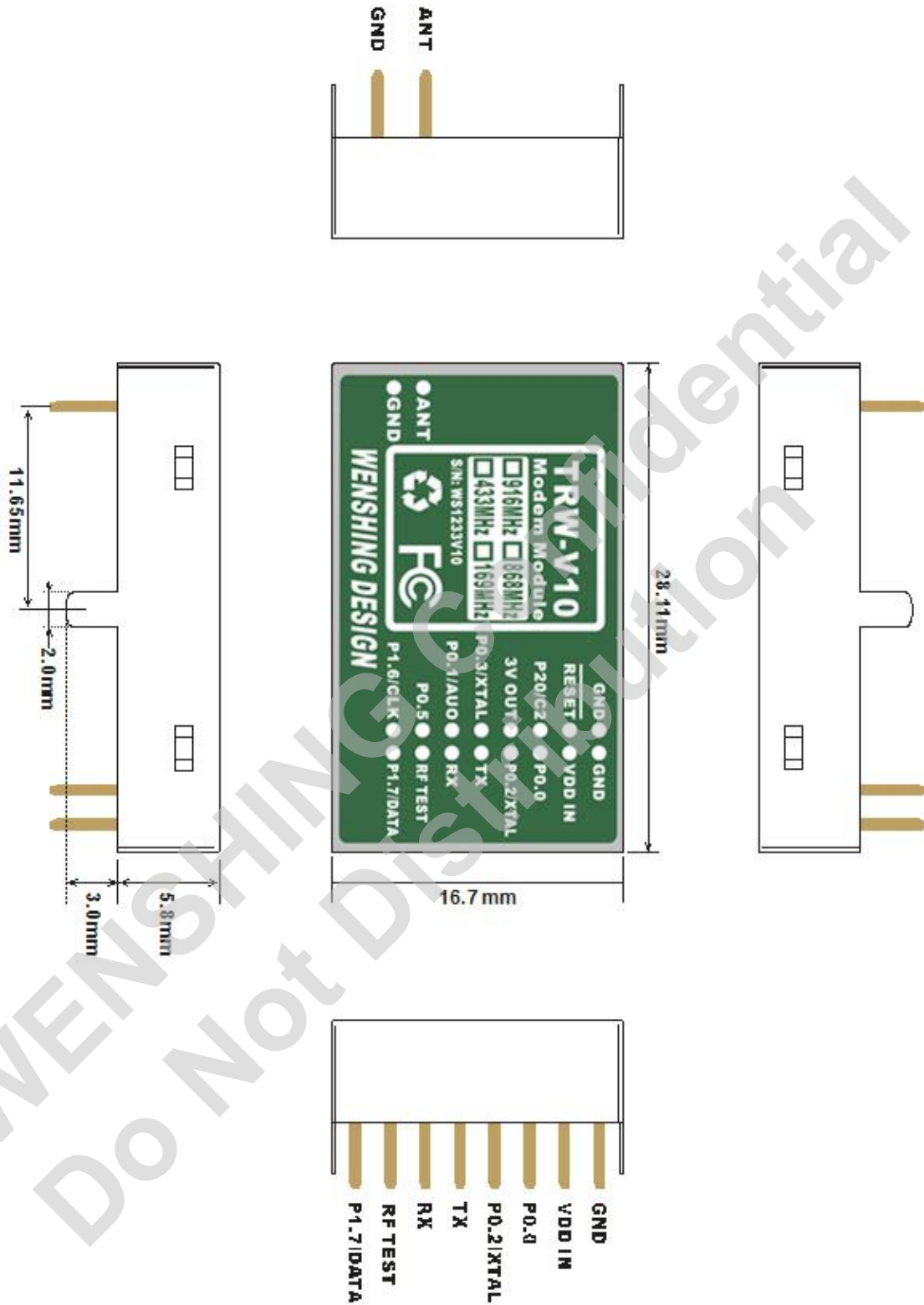

Pin Assignment

Pin	Name	I/O	Description
1	ANT	I/O	To ext Antenna
2	GND	RF GND	RF GND
3	GND	Ground	Ground
4	/RESET	I	Active low module reset
5	P20	I/O	General I/O usage
6	3V OUT	POWER	3V output can connect to current under 50mA.
7	P2.0/Crystal	I/O	General I/O usage, Option: can connect to 32.768KHz Crystal
8	P0.1/AUO	I/O	General I/O usage, Option: can be Data converted to analog (D/A)
9	P0.5	I/O	General I/O usage, Option: can be analog converted to Data (A/ D)
10	P1.6/CLK	I/O	General I/O usage, Option: can be used as I2C CLK
11	P1.7	I/O	General I/O usage, Option: can be used as I2C Date
12	P0.7	I/O	General I/O usage, (for producing test RF Pin)
13	RX	I	UR interface, (TTL 3V), can connect to RS-232 Chip TX
14	TX	O	UR interface, (TTL 3V), can connect to RS-232 Chip RX
15	P0.2/Crystal	I/O	General I/O Usage, Option: can connect to 32.768 KHz Crystal
16	P0.0	I/O	General I/O Usage,
17	VDD IN	POWER	Power Supply 3.7~5.5V
18	GND	Ground	Ground

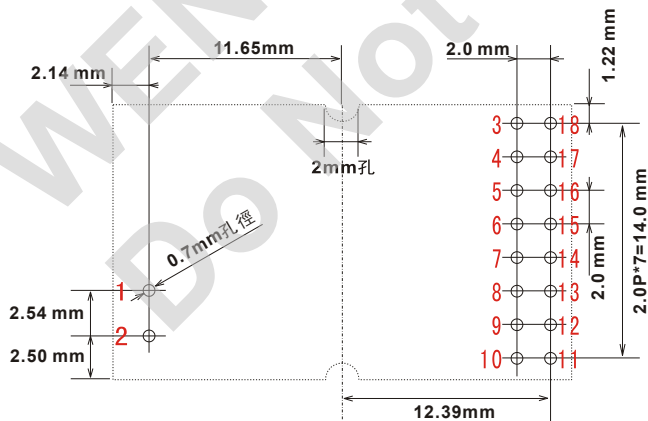

Reference hole position for PCB mounting(Top view)

- | | |
|-------------|--------------|
| 3 GND | 18 GND |
| 4 RESET | 17 VDD IN |
| 5 P20/C2 | 16 P0.0 |
| 6 3V OUT | 15 P0.2/XTAL |
| 7 P0.3/XTAL | 14 TX |
| 8 P0.1/AUO | 13 RX |
| 1 ANT | 9 P0.5 |
| 2 GND | 10 P1.6/CLK |
| | 11 P1.7/DATA |

Instruction Mode

● Into set up mode :

Transmit value=0x01+0x02+~+7E+0x7F,total=127Bytes.

Receive value =0x01+0x02+~+7E+0x7F, total=127Bytes , and it transit 0x53 hint notes every second to tell user that it is on instruction mode.

✧ It needs to be in the set up mode to read or amend any parameter.

● Exit code mode :

Transmit value = 0xFF FF FF 55 CC

Receive value = nothing, it stop transit back 0x53 hint notes every second.

✧ It needs to be in the set up mode.

● Read in product name and model :

Transmit value =0xFF FF FF 55 AA BB FD

Receive value (no character) =TRW-V10_V001

✧ It has information total in 11Bytes, the first six characters is product name and last four characters are firmware (the contents will be a little different in different version).

● Recover parameter :

Transmit value =0xFF FF FF 55 AA BB FF

Receive value = nothing

✧ Delete the original parameter, and recover back to the new set code that is written in when it is out from factory.

● Read in inside parameter :

Transmit value =0xFF FF FF 55 AA BB FE

Receive value =0x03 00 00 00 00 05 0E 1D 48 07 00 00 FF (this is the out from factory mode)

✧ It has information that totals in 31Bytes, it is set inside parameter at present.

● Set inside parameter :

Transmit value =0xFE 03 00 00 00 00 05 0E 1D 48 07 00 00 FF , It transit 32 Bytes in total.

Receive value =0xFD 03 00 00 00 00 05 0E 1D 48 07 00 00 FF , it is 32Bytes in total transit back. It means it is same as the inside parameter if the first Byte shows FE, after it finish the update.

✧ It is 31Bytes in total, change every parameter.

✧ The first Byte: the starting parameter, 0xFE

- ✧ The second Byte: interface speed rate, set up range 00~07, the beginning rate is 9600bps.

Value	0	1	2	3	4	5	6	7
Rate(bps)	1200	2400	4800	9600	19.2K	38.4K	57.6K	115.2K

- ✧ The third~ forth Byte : group (GID) , set up range 0000~FFFF
- ✧ The fifth Byte : instrument ID(SID) , set up range 00~FF
- ✧ The sixth Byte : wrong parameter, fixed as 0x00
- ✧ The seventh Byte : transmit rate, set up range 00~07; Normally, the RF transmit rate must greater than interface speed rate when setting up, it prevent having the wrong information.

Value	0	1	2	3	4	5	6	7
Rate(bps)	1600	3200	6400	12.8K	25.6K	51.2K	76.8K	128K

- ✧ The eighth ~ tenth Byte : working frequency, calculation:
 $\text{MHz} \times 1000 = \text{KHz}$, and transfer to 16 Bytes.
 For example: when it is at 925MHz working frequency ,
 $925 \times 1000 = 925000 = 0x0E\ 1D\ 48$ fill in 0E in the eighth Byte, fill in 1D in the ninth Byte, fill in 48 in the tenth Byte.
 When it is at 924.5MHz working frequency, $924.5 \times 1000 = 924500 = 0x0E\ 1B\ 54$;
 fill in 0E in the eighth Byte, fill in 1B in the ninth Byte, fill in 54 in the tenth Byte.
- ✧ The eleventh Byte :
 Bit0~Bit2 : shooting rate , set up range 0~7

Output Power		
dBm	Set Value	Hex (Bit0~Bit2)
5	0	000
12	1	001
17	2	010
21	3	011
24	4	100
25	5	101
26	6	110
27	7	111

Bit3~Bit5 : wrong parameter , fixed as 000

Bit6~Bit7 : instrument working mode , there are four mode:

0 Mode 1 (long data mode: set up as 00) :

GID of every instrument can receive info at this mode, and it can specifically use on data info that is larger than 127Bytes.

0 Mode 2 (ID: info mode 1 : set up as 01) :

Once GID can transmit to particular SID instrument under this mode, it is one to many; the single info must ≤ 127 Bytes.

0 Transmission: The first Byte is the SID of the receiver, and from the second byte, it becomes data.

Example: The SID of device A is 55, the SID of device B is 88, and they have the same GID. Under mode 2, device A is going to transmit data 0x1234567890, 5 Bytes in total, to B device, A then sends data 0x881234567890, 6Bytes in total to B, B will receive 0x551234567890, 6Byte in total. The first Byte is the SID of the transmitter.

0 Mode 3 (ID: info mode 2 : set up as 10) :

Once GID can transmit to particular SID instrument under this mode, it is one to many; the single info must ≤ 127 Bytes.

Transmission: Data shall be transmitted under the same rule of the thirteen to thirty-two Byte.

Example: The GID of device A = AAAA, SID = 55; the GID of device B = BBBB, SID = 88; the GID of device C = CCCC, SID = 99.

A is going to transmit 0x1234567890 to B, 5 Bytes in total. A then sends 0x04FFBBBB881234567890, 10 Bytes in total, to B, B will receive 0x1234567890, 5 Bytes in total.

A is going to transmit 0x1234567890, 5 Bytes in total, to B via C. A then sends 0x08FFBBBB88FFCCCC991234567890, 14 Bytes in total, C will receive 0x1234567890, 5 Bytes in total, but B will not receive any data.

0 Mode 4 (saved ID data mode: set up as 11) :

It can set in advance to save particular GID and SID way, it will transmit it back referring to the track it is saved. It can forward the track up to fourteen times, the single info must ≤ 127 Bytes.

- ✧ The twelfth Byte : wrong parameter, it fixed as 0x00.
- ✧ The thirteenth ~ the thirty-two Byte : the pre saved track, it only works under mode 4 (saved ID data mode).
- ✧ The thirteenth Byte : It shows how much information in the fourteenth Byte ~thirty-two Byte.
- ✧ The fourteenth Byte ~ thirty-two Byte road formation:

◆ **Example 1: 04 FF 12 34 55 11 22 33 44 ~ 00**

You can know there is four Bytes effective information as FF 12 34 55 from the thirteen Byte.

FF 12 34 55 means GID=1234 、SID=55, this instrument will forward information to GID=1234 、SID=55 once UR instrument after receiving it.

◆ **Example 2: 05 FF 12 34 55 11 22 33 44 ~ 00**

You can know there is five byte effective information as FF 12 34 55 11 from the thirteen Byte.

FF 12 34 55 11 means, GID=1234 、SID=55 及 11 , this instrument will forward information to GID=1234 、SID=11 instrument after this instrument transmit information automatically to GID=1234 、SID=55 when receiving it through UR.

◆ **Example 3 : 06 FF 12 34 55 11 22 33 44 ~ 00**

You can know there is six Bytes effective information as FF 12 34 55 11 22 from the thirteenth Byte.

FF 12 34 55 11 22 means GID=1234 、SID=55 、11 and 22.

It will forward information to GID=1234 、SID=11 instrument and GID=1234 、SID=22 after this instrument transmit information automatically to GID=1234 、SID=55 after receiving it through UR.

◆ **Example 4 : 08 FF 12 34 55 FF 45 67 88 44 ~ 00**

You can know there is eight Bytes effective information as FF 12 34 55 FF 45 67 88.

FF 12 34 55 FF 45 67 88 means GID=1234 、SID=55 and

GID=4567 、SID=88. This instrument will forward information to

GID=4567 、SID=88 instrument once this instrument transmit

information automatically to GID=1234 、SID=55 when receiving it through UR.

Demo Circuit 1

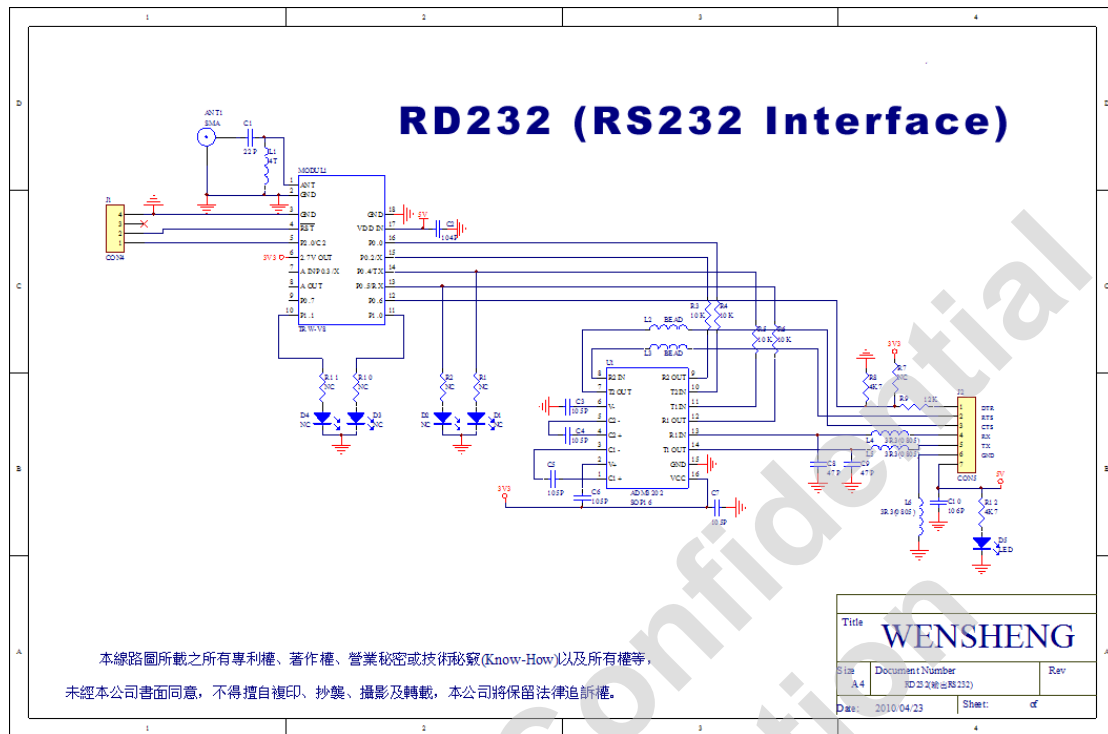

Demo Circuit 2

