

Si photodiode S5493-01, etc.

Photodiodes molded into clear plastic packages

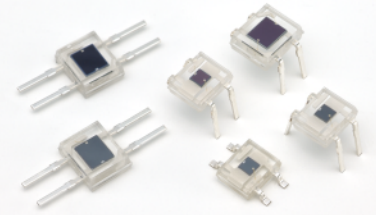

These are Si photodiodes molded into clear plastic packages.

Spectral response characteristics for these Si photodiodes can be selected to meet your application, from among the visible range, visible to near IR range, and visible to infrared range. Two active areas of 1.3 × 1.3 mm and 2.4 × 2.8 mm are also available.

S5493-01 and S5627-01 provide a spectral response characteristic similar to the visible range sensitivity without using visual-compensated filters.

Features

- S5493-01, S5627-01: Visible range (Filterless type)
- S4797-01, S6931 : Visible to near IR range
- S2833-01, S4011-04: Visible to infrared range

Applications

- Exposure meter
- Illuminometer
- Camera auto exposure
- Stroboscope light control
- Copier
- Display light control
- Optical switch

General ratings / Absolute maximum ratings

Type No.	Dimensional outline/ Window material *	Active area size (mm)	Effective active area (mm ²)	Absolute maximum ratings		
				Reverse voltage V _R Max. (V)	Operating temperature T _{opr} (°C)	Storage temperature T _{stg} (°C)
S5493-01	①/R	2.4 × 2.8	6.6	10	-25 to +85	-40 to +100
S5627-01	②/R	1.3 × 1.3	1.6			
S6931	③/R	2.4 × 2.8	6.6			
S4797-01	④/R	1.3 × 1.3	1.6			
S2833-01	⑤/R	2.4 × 2.8	6.6			
S4011-04	⑥/R	1.3 × 1.3	1.6			

* Window material R: clear resin coating

Electrical and optical characteristics (Typ. T_a=25 °C, unless otherwise noted)

Type No.	Spectral response range λ (nm)	Peak sensitivity wavelength λ _p (nm)	Photo sensitivity S (A/W)			Infrared sensitivity ratio (%)	Short circuit current I _{sc} 100 lx (μA)	Temp. coefficient of I _{sc} (%/°C)	Dark current I _D V _R =1 V Max. (pA)	Temp. coefficient of I _D T _{CID} (times/°C)	Rise time t _r V _R =0 V R _L =1 kΩ (μs)	Terminal capacitance C _t V _R =0 V f=10 kHz (pF)	Shunt resistance R _{sh} V _R =10 mV	
			λ _p	GaP LED 560 nm	He-Ne Laser 633 nm								Min. (GΩ)	Typ. (GΩ)
S5493-01	320 to 840	540	0.3	0.28	0.2	35	1.0	0.25	100	1.13	10	3000	0.1	1
S5627-01														
S6931	320 to 1000	720	0.48	0.4	0.45	-	4.2	0.1	20	1.12	0.5	200	10	50
S4797-01			0.4											
S2833-01	320 to 1100	960	0.58	0.33	0.38	-	6.5	0.1	10	1.12	2.5	700	10	100
S4011-04														

■ Spectral response

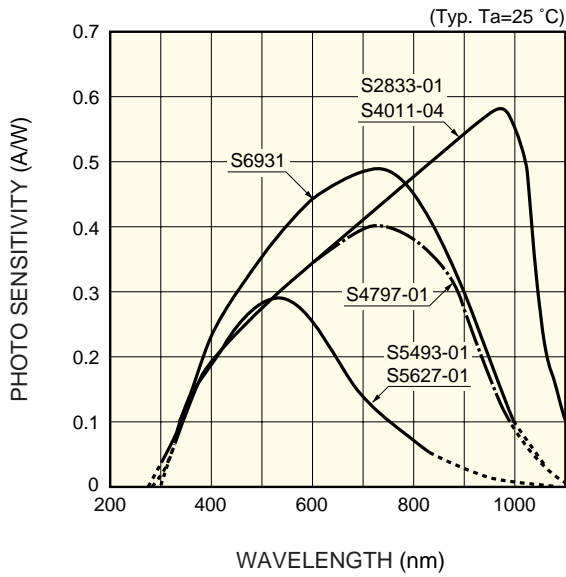

KSPDB0129EB

■ Rise time vs. load resistance

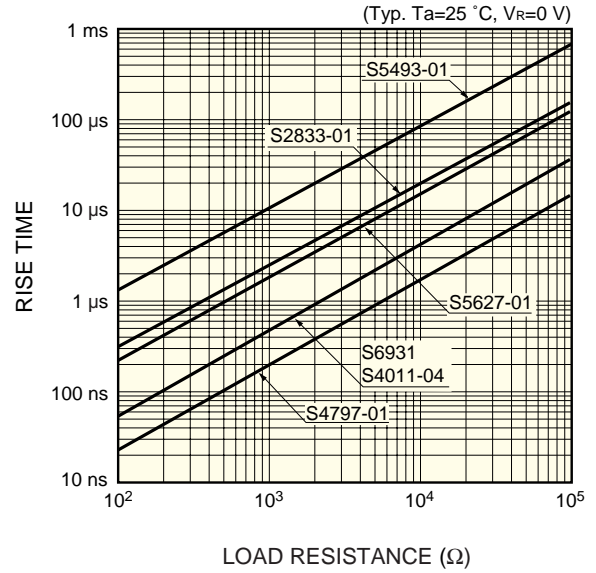

KSPDB0130EC

■ Dark current vs. reverse voltage

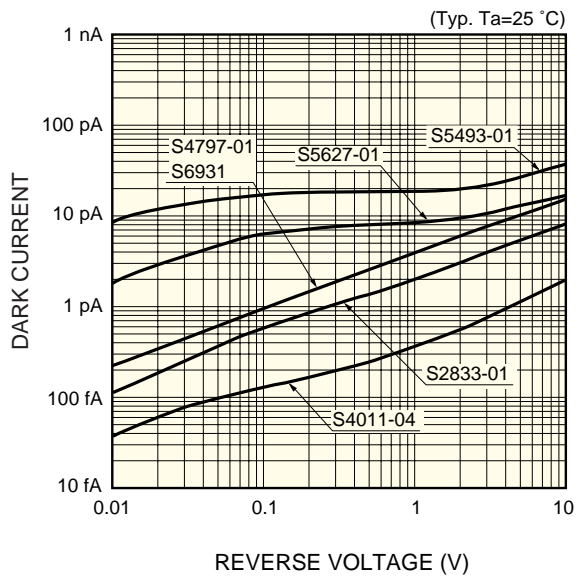

KSPDB0131EB

■ Shunt resistance temperature characteristics

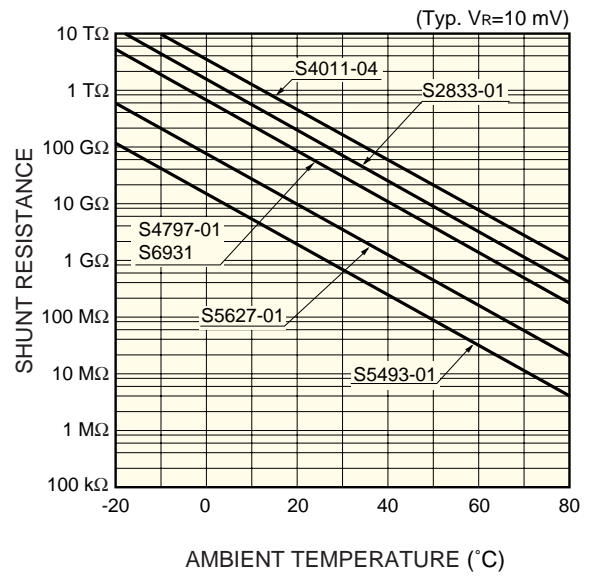

KSPDB0132EB

■ Dimensional outlines (unit: mm, tolerance unless otherwise noted: ± 0.1 mm)

① S5493-01

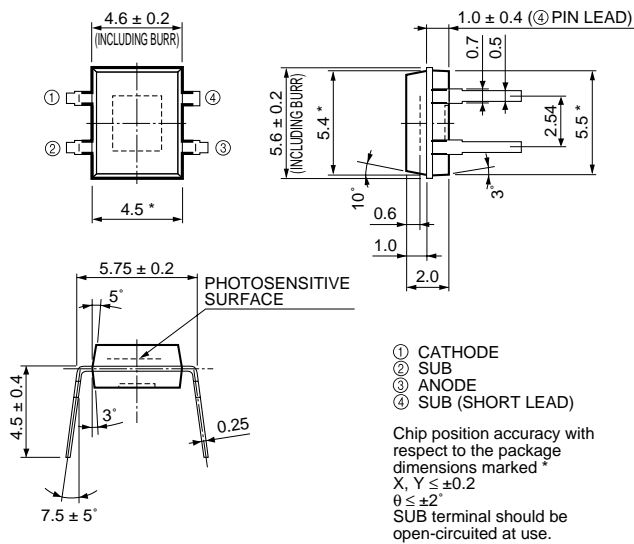

KSPDA0118EA

② S5627-01

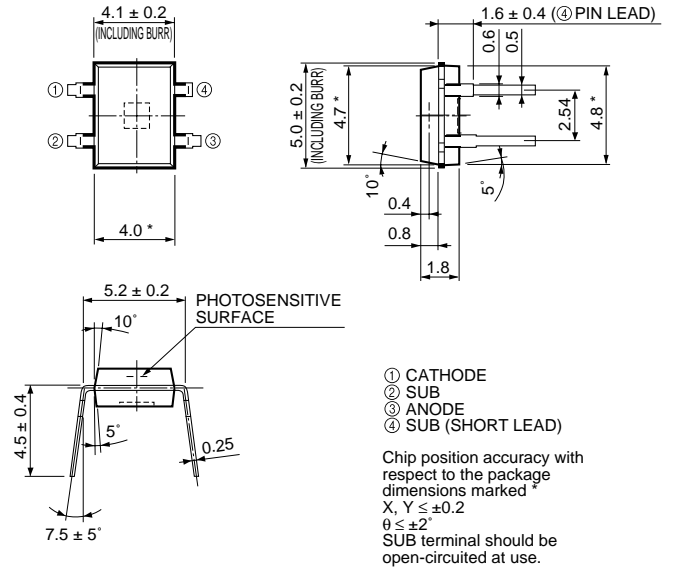

KSPDA0119EA

③ S6931

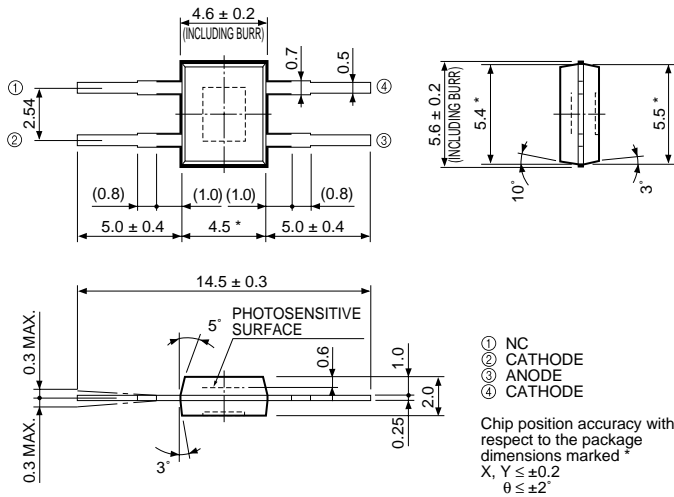

KSPDA0122EA

④ S4797-01

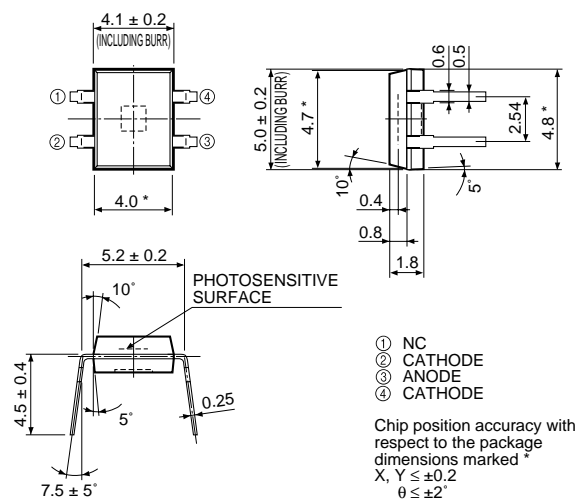

KSPDA0121EA

⑤ S2833-01

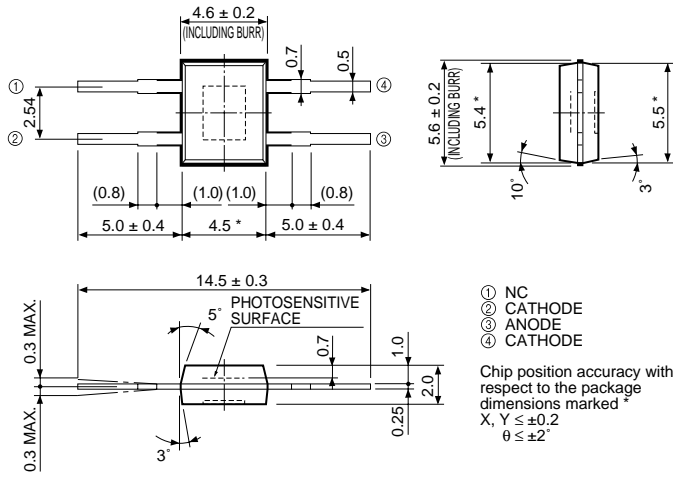

KSPDA0123EA

⑥ S4011-04

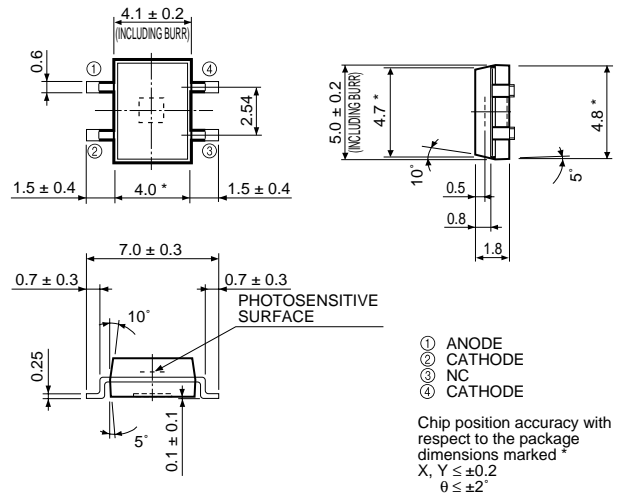

KSPDA0163EA

HAMAMATSU

Information furnished by HAMAMATSU is believed to be reliable. However, no responsibility is assumed for possible inaccuracies or omissions. Specifications are subject to change without notice. No patent rights are granted to any of the circuits described herein. ©2003 Hamamatsu Photonics K.K.

HAMAMATSU PHOTONICS K.K., Solid State Division

1126-1 Ichino-cho, Higashi-ku, Hamamatsu City, 435-8558 Japan, Telephone: (81) 53-434-3311, Fax: (81) 53-434-5184, <http://www.hamamatsu.com>

U.S.A.: Hamamatsu Corporation: 360 Foothill Road, P.O.Box 6910, Bridgewater, N.J. 08807-0910, U.S.A., Telephone: (1) 908-231-0960, Fax: (1) 908-231-1218

Germany: Hamamatsu Photonics Deutschland GmbH: Arzbergerstr. 10, D-82211 Herrsching am Ammersee, Germany, Telephone: (49) 08152-3750, Fax: (49) 08152-2658

France: Hamamatsu Photonics France S.A.R.L.: 19, Rue du Saule Trapu, Parc du Moulin de Massy, 91882 Massy Cedex, France, Telephone: 33-(1) 69 53 71 00, Fax: 33-(1) 69 53 71 10

United Kingdom: Hamamatsu Photonics UK Limited: 2 Howard Court, 10 Tewin Road, Welwyn Garden City, Hertfordshire AL7 1BW, United Kingdom, Telephone: (44) 1707-294888, Fax: (44) 1707-325777

North Europe: Hamamatsu Photonics Norden AB: Smidesvägen 12, SE-171 41 Solna, Sweden, Telephone: (46) 8-509-031-00, Fax: (46) 8-509-031-01

Italy: Hamamatsu Photonics Italia S.R.L.: Strada della Moia, 1/E, 20020 Arese, (Milano), Italy, Telephone: (39) 02-935-81-733, Fax: (39) 02-935-81-741