

MATERIALS

BODY	BRASS NICKEL PLATED
CONTACT	GOLD PLATED
BNC INSULATOR	PTFE
F INSULATOR	POLYPROPYLENE

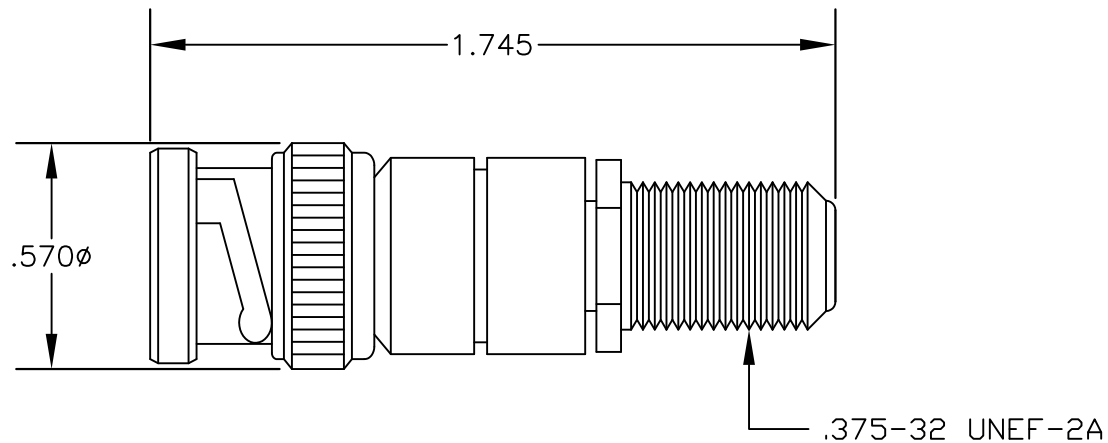

SPECIFICATIONS

FREQUENCY RANGE: DC TO 3 GHz
 MAX VSWR 1.30:1



PASTERNACK ENTERPRISES, INC.

P.O BOX 16759, IRVINE, CA 92623
 PHONE (949) 261-1920 FAX (949) 261-7451

WEB ADDRESS: www.pasternack.com
 E-MAIL ADDRESS: sales@pasternack.com

COAXIAL & FIBER OPTICS

DWG TITLE

PE9741

DES. 75 OHM BNC MALE TO F FEMALE

SIZE A	FSCM NO. 53919	CAD FILE 050703	SCALE N/A	127
--------	----------------	-----------------	-----------	-----

NOTES:

1. UNLESS OTHERWISE SPECIFIED ALL DIMENSIONS ARE NOMINAL.
2. ALL SPECIFICATIONS ARE SUBJECT TO CHANGE WITHOUT NOTICE AT ANY TIME.