

856908

836.5/881.5 MHz SAW Duplexer

Applications

- General purpose wireless
- Femtocells
- Repeaters
- Data cards and dongles

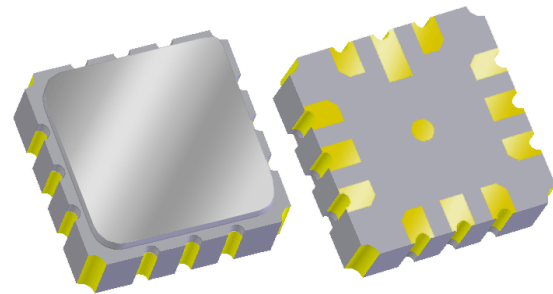

Product Features

- Usable bandwidth 25 MHz
- No matching required for operation at 50Ω
- Excellent rejection for Bluetooth and GPS operation
- Suitable for Automotive applications - Compliant to the AEC-Q200 reliability standard. Manufacturing facilities are certified with ISO/TS 16949:2002
- High Isolation
- High Rejection
- Ceramic Surface Mount Package (SMP)
- Small Size : 3.8 x 3.8 x 1.47 mm
- Hermetic **RoHS** compliant, **Pb-free** 

Functional Block Diagram

Top view

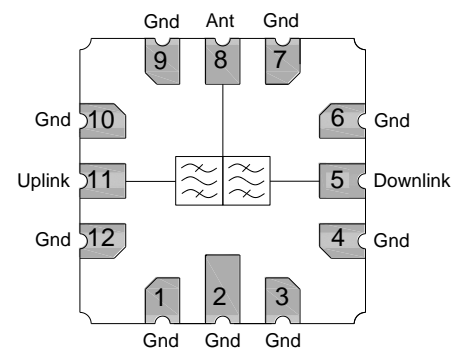

General Description

856908 is a Band V duplexer in a compact size for use in Femtocells, coverage enhancement repeaters, data cards, and other wireless data applications. Designed for rejection of unwanted Bluetooth and GPS signals, this SAW duplexer also has excellent power handling capability for low power transmitters.

Housed in a 3.8 x 3.8 mm hermetic package, this device allows for a compact and cost effective duplexer solution for Band V applications.

No matching components are required, making the PCB design and implementation easy.

Pin Configuration

Pin # SE	Description
5	Downlink
8	Antenna
11	Uplink
1,2,3,4,6	Case Ground
7,9,10,12	Case Ground

Ordering Information

Part No.	Description
856908	packaged part
856908-EVB	evaluation board

Standard T/R size =4000 units/reel.

Specifications

Electrical Specifications ⁽¹⁾

Specified Temperature Range: ⁽²⁾ -30 to +85 °C

Uplink Specifications					
Parameter ⁽³⁾	Conditions	Min	Typical ⁽⁴⁾	Max	Units
Center Frequency		-	836.5	-	MHz
Maximum Insertion Loss	824 – 849 MHz	-	2.0	2.5	dB
Amplitude Ripple	824 – 849 MHz	-	0.25	1.0	dB p-p
Absolute Attenuation	869 – 894 MHz	42.5	44.7	-	dB
	1574 – 1577 MHz	38	42.4	-	dB
	1648 – 1698 MHz	35	45	-	dB
	1850 – 2170 MHz	27	35.7	-	dB
	2472 – 2547 MHz	15	22.6	-	dB
Return Loss at Uplink Terminal ⁽⁵⁾	824 – 849 MHz	9.5	12	-	dB
Input Power ⁽⁶⁾	824 – 849 MHz			+27	dBm

Downlink Specifications					
Parameter ⁽³⁾	Conditions	Min	Typical ⁽⁴⁾	Max	Units
Center Frequency		-	881.5	-	MHz
Maximum Insertion Loss	869 – 894 MHz	-	2.5	3.5	dB
Amplitude Ripple	869 – 894 MHz	-	0.4	2.2	dB p-p
Absolute Attenuation	824 – 849 MHz	50	55.3	-	dB
	1570 – 1580 MHz	40	56.0	-	dB
	1850 – 2170 MHz	33	41.0	-	dB
	2400 – 2484 MHz	15	23.4	-	dB
Return Loss at Downlink Terminal ⁽⁵⁾	869 – 894 MHz	9.5	10.8	-	dB
Input Power ⁽⁶⁾	869 – 894 MHz			+24	dBm

Uplink-Downlink Specifications					
Parameter ⁽³⁾	Conditions	Min	Typical ⁽⁴⁾	Max	Units
Uplink-Downlink Isolation	824 – 849 MHz	50	56.9	-	dB
	849 – 869 MHz	34	38.4	-	dB
	869 – 894 MHz	45	46.4	-	dB
Source/Load Impedance (single-ended) ⁽⁷⁾		-	50	-	Ω

Notes:

- All specifications are based on the TriQuint schematics for the reference designs shown on page 4
- In production, devices will be tested at room temperature to a guardbanded specification to ensure electrical compliance over temperature
- Electrical margin has been built into the design to account for the variations due to temperature drift and manufacturing tolerances
- Typical values are based on average measurements at room temperature on pcb
- Excluding losses due to PCB
- CW signal at 55°C for 10,000 hours
- This is the optimum impedance in order to achieve the performance shown

Absolute Maximum Ratings

Parameter	Rating
Operable Temperature	-40 to +85 °C
Storage Temperature	-40 to +85 °C

Operation of this device outside the parameter ranges given above may cause permanent damage.

Specifications

Electrical Specifications ⁽¹⁾

Specified Temperature Range: ⁽²⁾ -40 to +85 °C

Uplink Specifications					
Parameter ⁽³⁾	Conditions	Min	Typical ⁽⁴⁾	Max	Units
Center Frequency		-	836.5	-	MHz
Maximum Insertion Loss	824 – 849 MHz	-	2.0	2.9	dB
Amplitude Ripple	824 – 849 MHz	-	0.25	1.0	dB p-p
Absolute Attenuation	869 – 894 MHz	42.5	44.7	-	dB
	1574 – 1577 MHz	37.5	42.4	-	dB
	1648 – 1698 MHz	35	45	-	dB
	1850 – 2170 MHz	27	35.7	-	dB
	2472 – 2547 MHz	15	22.6	-	dB
Return Loss at Uplink Terminal ⁽⁵⁾	824 – 849 MHz	9.3	12	-	dB
Input Power ⁽⁶⁾	824 – 849 MHz			+27	dBm

Downlink Specifications					
Parameter ⁽³⁾	Conditions	Min	Typical ⁽⁴⁾	Max	Units
Center Frequency		-	881.5	-	MHz
Maximum Insertion Loss	869 – 894 MHz	-	2.5	3.9	dB
Amplitude Ripple	869 – 894 MHz	-	0.4	2.2	dB p-p
Absolute Attenuation	824 – 849 MHz	50	55.3	-	dB
	1570 – 1580 MHz	40	56.0	-	dB
	1850 – 2170 MHz	33	41.0	-	dB
	2400 – 2484 MHz	15	23.4	-	dB
Return Loss at Downlink Terminal ⁽⁵⁾	869 – 894 MHz	9.5	10.8	-	dB
Input Power ⁽⁶⁾	869 – 894 MHz			+24	dBm

Uplink-Downlink Specifications					
Parameter ⁽³⁾	Conditions	Min	Typical ⁽⁴⁾	Max	Units
Uplink-Downlink Isolation	824 – 849 MHz	50	56.9	-	dB
	849 – 869 MHz	34	38.4	-	dB
	869 – 894 MHz	45	46.4	-	dB
Source/Load Impedance (single-ended) ⁽⁷⁾		-	50	-	Ω

Notes:

- All specifications are based on the TriQuint schematics for the reference designs shown on page 4
- In production, devices will be tested at room temperature to a guardbanded specification to ensure electrical compliance over temperature
- Electrical margin has been built into the design to account for the variations due to temperature drift and manufacturing tolerances
- Typical values are based on average measurements at room temperature on pcb
- Excluding losses due to PCB
- CW signal at 55°C for 10,000 hours
- This is the optimum impedance in order to achieve the performance shown

Absolute Maximum Ratings

Parameter	Rating
Operable Temperature	-40 to +85 °C
Storage Temperature	-40 to +85 °C

Operation of this device outside the parameter ranges given above may cause permanent damage.

Reference Design – 50Ω SE Input, 50Ω SE Output

Schematic

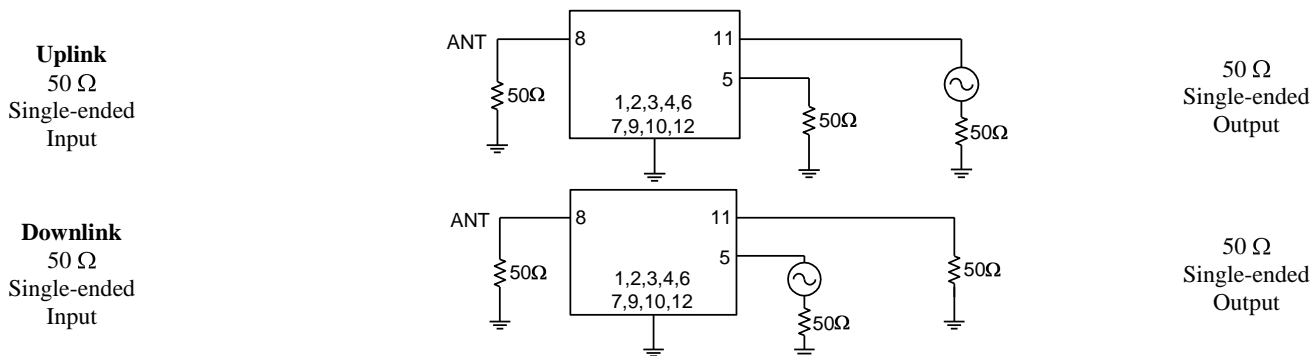

Notes:

1. No impedance matching required
2. Actual matching values may vary due to PCB layout and parasitic

PC Board

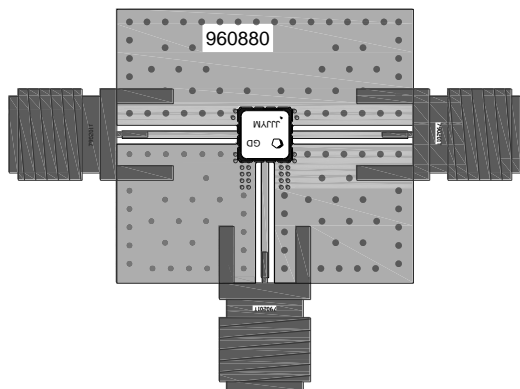

Notes:

- Top, middle & bottom layers: 1 oz copper
- Substrates: FR4 dielectric, .031" thick
- Finish plating: Nickel: 3-8μm thick, Gold: .03-.2μm thick
- Hole plating: Copper min .0008μm thick

Mounting Configuration

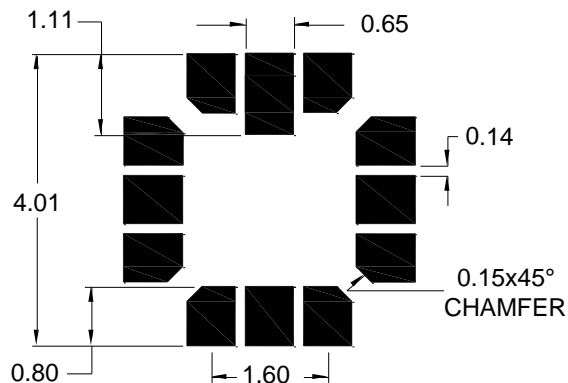

Notes:

1. All dimensions are in millimeters.
2. This footprint represents a recommendation only.

Bill of Material

Reference Desg.	Value	Description	Manufacturer	Part Number
SMA	N/A	SMA connector	Radiall USA Inc.	9602-1111-018
PCB	N/A	3-layer	multiple	960880

Typical Performance (at room temperature)

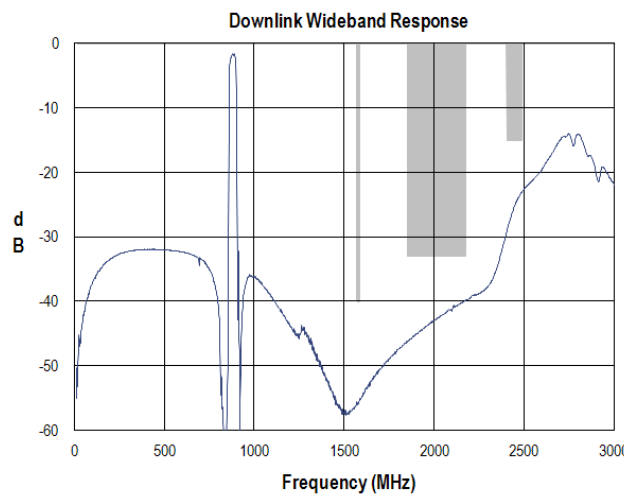
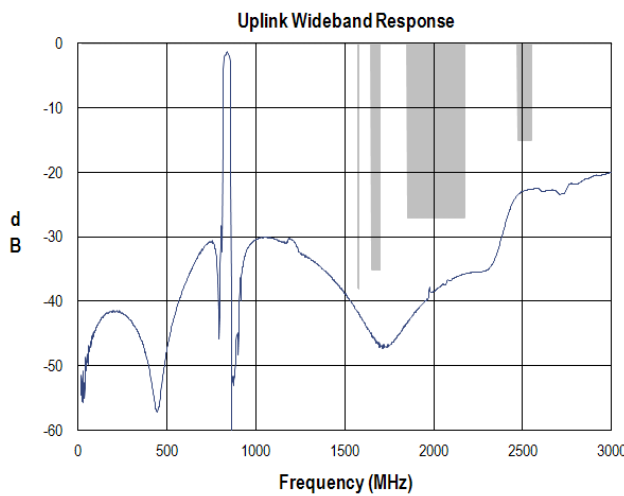
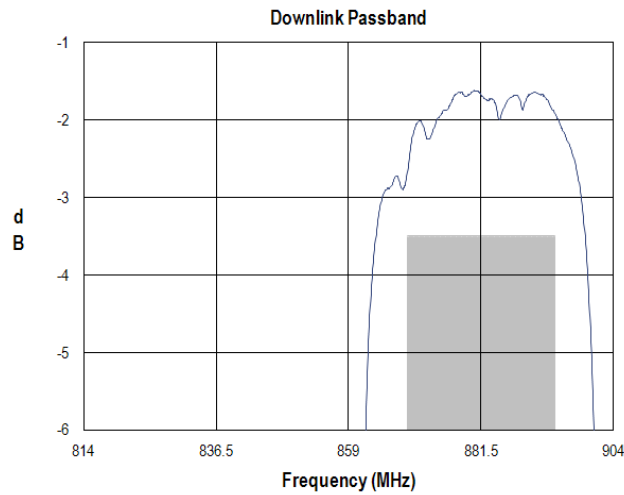
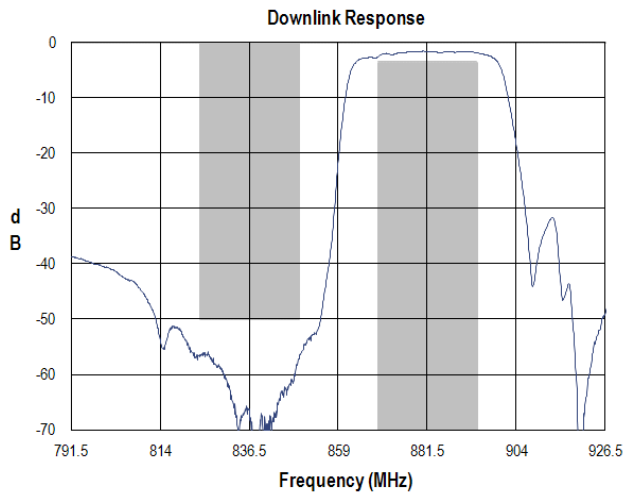
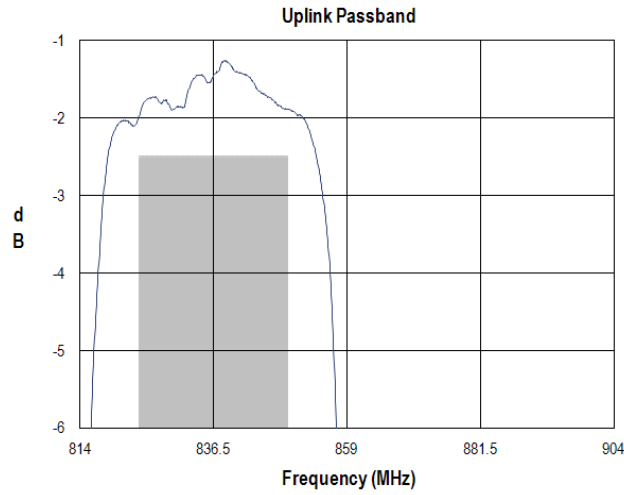
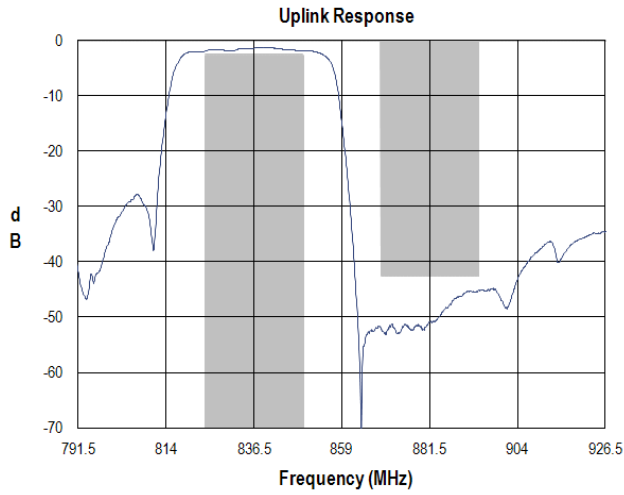

856908

836.5/881.5 MHz SAW Duplexer

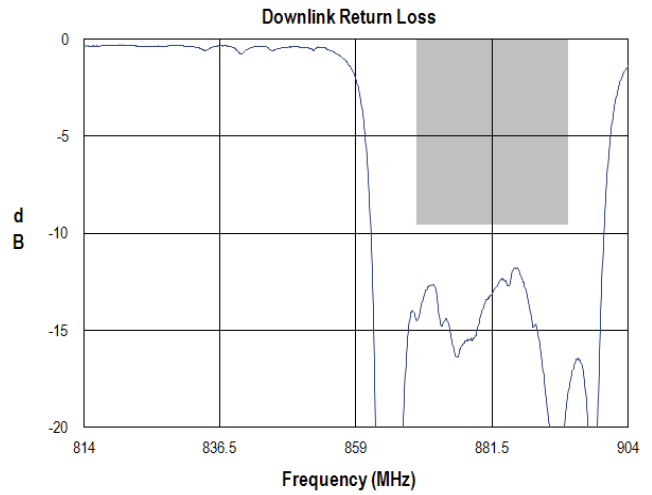
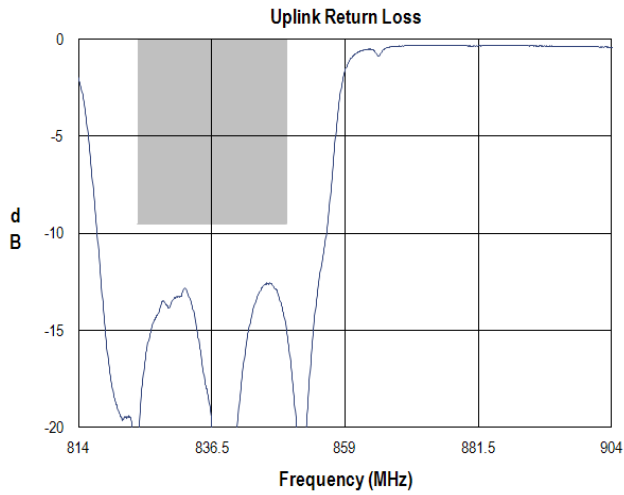
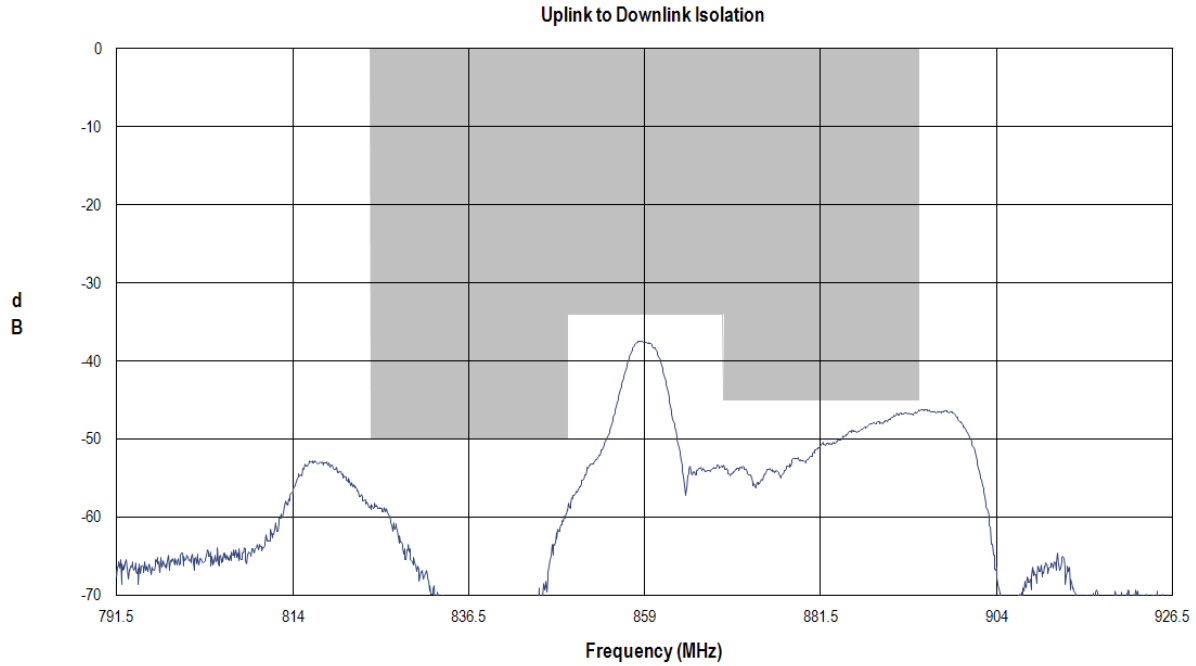

856908

836.5/881.5 MHz SAW Duplexer

Mechanical Information

Package Information, Dimensions and Marking

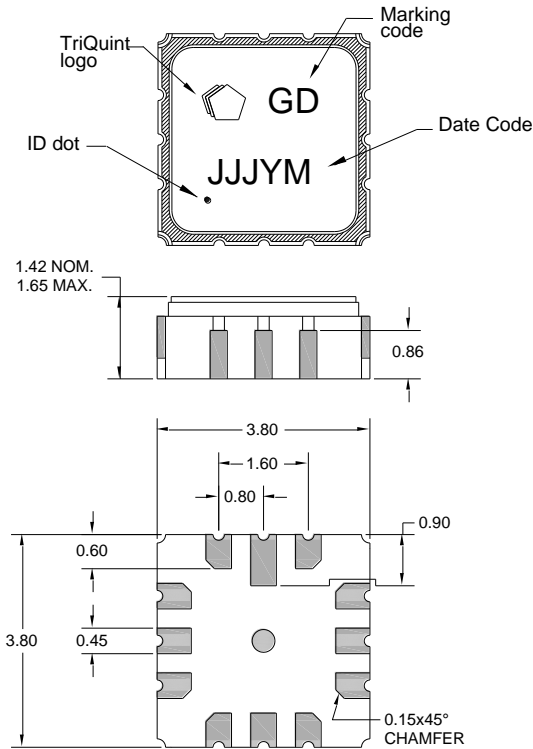

Package Style: SMP-15N
Dimensions: 3.8 x 3.8 x 1.42 mm

Body: Al_2O_3 ceramic
Lid: Kovar, Ni plated
Terminations: Au plating 0.5 - 1.0 μm , over a 2-6 μm Ni plating

All dimensions shown are nominal in millimeters
All tolerances are $\pm 0.15 mm$ except overall length and width $\pm 0.10 mm$

The date code consists of: day of the current year (Julian, 3 digits), Y = last digit of the year, and M = manufacturing site code

Tape and Reel Information

Standard T/R size = 4000 units/reel. All dimensions are in millimeters

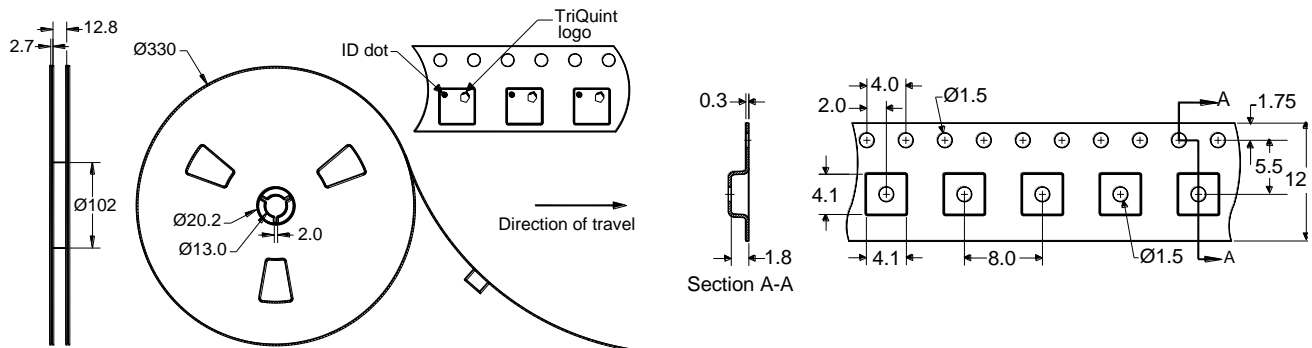

856908

836.5/881.5 MHz SAW Duplexer

Product Compliance Information

ESD Information



Caution! ESD-Sensitive Device

ESD Rating: 1A

Value: Passes ≥ 300 V min.
Test: Human Body Model (HBM)
Standard: JEDEC Standard JESD22-A114

ESD Rating: B

Value: Passes ≥ 200 V min.
Test: Machine Model (MM)
Standard: JEDEC Standard JESD22-A115

MSL Rating

Devices are Hermetic, therefore MSL is not applicable

Solderability

Compatible with the latest version of J-STD-020, lead free solder, 260°C

Refer to [Soldering Profile](#) for recommended guidelines.

This part is compliant with EU 2002/95/EC RoHS directive (Restrictions on the Use of Certain Hazardous Substances in Electrical and Electronic Equipment).

This product also has the following attributes:

- Halogen Free (Chlorine, Bromine)
- Antimony Free
- TBBP-A (C₁₅H₁₂Br₄O₂) Free
- PFOS Free
- SVHC Free

Contact Information

For the latest specifications, additional product information, worldwide sales and distribution locations, and information about TriQuint:

Web: www.triquint.com Tel: +1.407.886.8860
Email: info-sales@tqs.com Fax: +1.407.886.7061

For technical questions and application information:

Email: flapplication.engineering@tqs.com

Important Notice

The information contained herein is believed to be reliable. TriQuint makes no warranties regarding the information contained herein. TriQuint assumes no responsibility or liability whatsoever for any of the information contained herein. TriQuint assumes no responsibility or liability whatsoever for the use of the information contained herein. The information contained herein is provided "AS IS, WHERE IS" and with all faults, and the entire risk associated with such information is entirely with the user. All information contained herein is subject to change without notice. Customers should obtain and verify the latest relevant information before placing orders for TriQuint products. The information contained herein or any use of such information does not grant, explicitly or implicitly, to any party any patent rights, licenses, or any other intellectual property rights, whether with regard to such information itself or anything described by such information.

TriQuint products are not warranted or authorized for use as critical components in medical, life-saving, or life-sustaining applications, or other applications where a failure would reasonably be expected to cause severe personal injury or death.