



L3010

LINEAR INTEGRATED CIRCUIT

1A HIGH POWER LED DRIVER WITH 4.5~40V INPUT

DESCRIPTION

The UTC **L3010** is a step-down PWM control LED driver with a built-in power Switch. It achieves 1A continuous output current in 4.5~40V input voltage range. It has high efficiency up to more than 96%, with the excellent current accuracy within $\pm 1\%$.

FEATURES

- * 4.5~40V input voltage range
- * Maximum 1A output current
- * 0.25 Ω built-in power MOSFET
- * 280kHz fixed frequency
- * Excellent constant current accuracy $\pm 1\%$
- * High efficiency up to 96%
- * Thermal shutdown
- * Cycle-by-cycle over current protection

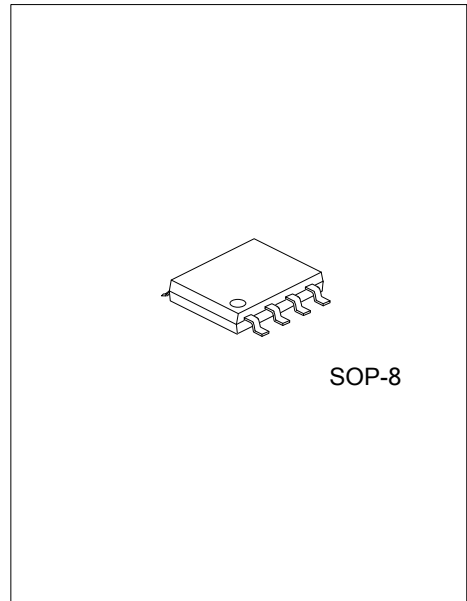

ORDERING INFORMATION

Ordering Number	Package	Packing
L3010G-S08-R	SOP-8	Tape Reel

<p>L3010G-S08-R</p> <ul style="list-style-type: none"> (1) Packing Type (2) Package Type (3) Green Package 	<ul style="list-style-type: none"> (1) R: Tape Reel (2) S08: SOP-8 (3) G: Halogen Free and Lead Free
---	---

MARKING

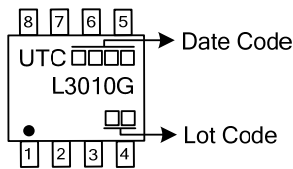

PIN CONFIGURATION

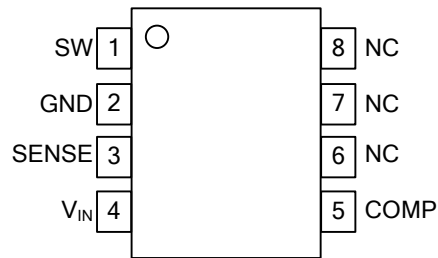

PIN DESCRIPTION

PIN NO.	PIN NAME	DESCRIPTION
1	SW	Power Switch output.
2	GND	Ground.
3	SENSE	Current sense pin.
4	V _{IN}	Input supply voltage.
5	COMP	Compensation pin, connects to external capacitor.
6~8	NC	No Connected.

BLOCK DIAGRAM

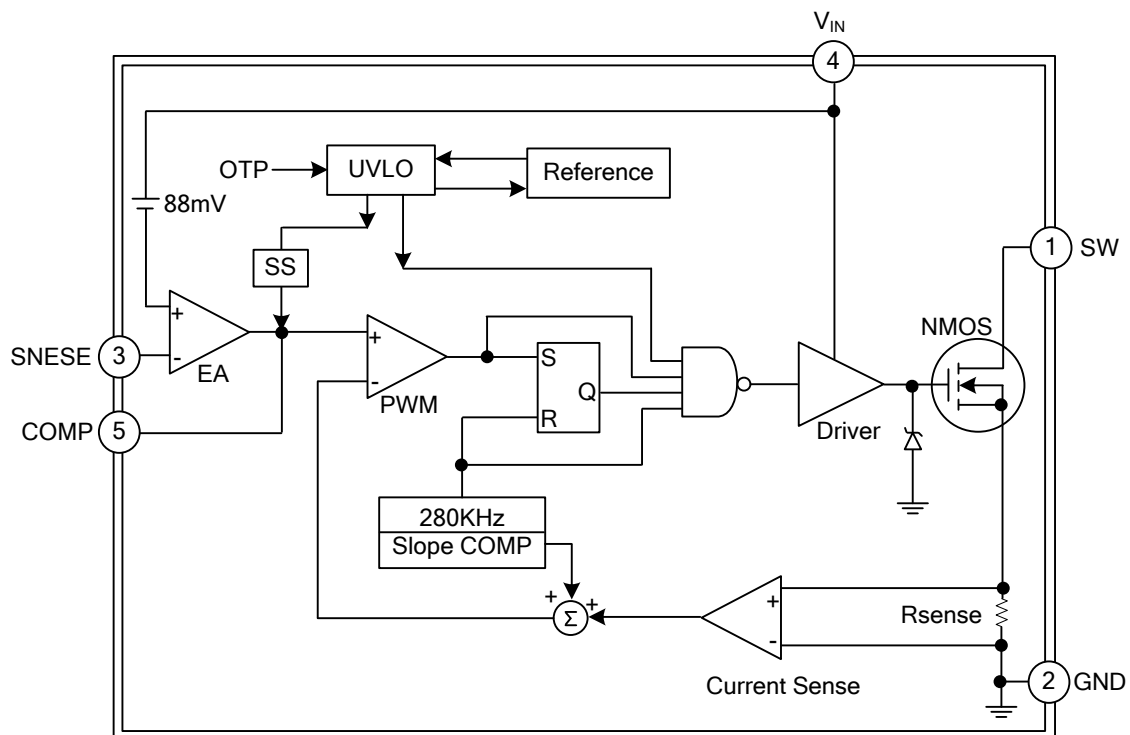

■ ABSOLUTE MAXIMUM RATING ($T_A = 25^\circ\text{C}$, unless otherwise specified)

PARAMETER	SYMBOL	RATINGS	UNIT
Supply Voltage	V_{IN}	43	V
Switch Voltage	V_{SW}	$-1 \sim V_{IN} + 1$	V
Comp Voltage	V_{COMP}	$-0.3 \sim 6$	V
SENSE Voltage	V_{SENSE}	$-0.3 \sim V_{IN}$	V
Input Voltage	V_{IN}	4.5~40	V
Junction Temperature	T_J	150	$^\circ\text{C}$
Operating Temperature	T_{OPR}	$-40 \sim +125$	$^\circ\text{C}$
Storage Temperature	T_{STG}	$-65 \sim +150$	$^\circ\text{C}$

Note: Absolute maximum ratings are those values beyond which the device could be permanently damaged. Absolute maximum ratings are stress ratings only and functional device operation is not implied.

■ ELECTRICAL CHARACTERISTICS ($V_{IN}=12\text{V}$, $I_{OUT}=700\text{Ma}$, $T_A=25^\circ\text{C}$, unless otherwise specified)

PARAMETER	SYMBOL	TEST CONDITIONS	MIN	TYP	MAX	UNIT
Supply Voltage	V_{IN}		4.5		40	V
Operating Current	I_{IN}	$V_{CC}=4/40\text{V}$ (Switch Off)		2.2	4	mA
Upper Switch Leakage	I_L	$V_{SW}=40\text{V}$		0	5	μA
Current Limit	I_{LIM}	$V_{IN}=\text{SENSE}=12\text{V}$	1.7	2.1	3	A
Maximum Duty Cycle	D_{MAX}	3LED, $V_{IN}=9\text{V}$		97		%
Oscillator Frequency	f_{OSC}		250	280	360	kHz
COMP Clamp Voltage	V_{COMP}	Open without load	1.6	2	2.2	V
Switch Transistor on Resistance	R_{ON}	1LED, $I_{OUT}=1\text{A}$		0.25	0.5	Ω
Sampling Voltage Threshold	$V_{IN}-V_{SENSE}$	Drop voltage between V_{IN} and SENSE		88		mV
Thermal Shutdown Threshold	TSD			160		$^\circ\text{C}$
Thermal Shutdown Hysteresis	TSD-hys			30		$^\circ\text{C}$

■ FUNCTION DESCRIPTION

The UTC **L3010** is a current mode and fixed frequency (280kHz) LED driver.

1. Output current setting

The output current is determined by the sampling resistor (R_S) and setting voltage ($V_{IN}-V_{SENSE}$ a built-in fixed 88mV).

$$I_{OUT} = \frac{V_{IN} - V_{SENSE}}{R_S} = 88mV/R_S$$

2. Current limiting

UTC **L3010** has internal current limiting function, and the voltage on COMP is clamped at about 2V, the output current of the power MOSFET is limited at about 2.1A by current comparator.

■ COMPONENTS SELECTION

1. Input Capacitor Selection

This capacitor should be located close to the IC using short leads. The RMS current rating requirement for the input capacitor of a buck regulator is approximately 1/2 the DC load current. A low ESR input capacitor sized for maximum RMS current must be used. It is recommend use the MLCC capacitor of 10 μ F or larger.

2. Output Capacitance Selection

The output capacitor is required to filter the output reduce the ripple current of LED and provide regulator loop stability. The important capacitor parameters are; The 100KHz Equivalent Series Resistance (ESR), the RMS ripples current rating, voltage rating, and capacitance value. For the output capacitor, the ESR value is the most important parameter. It is recommend use the MLCC capacitor of 2.2 μ F or larger.

3. Inductance Selection

For most designs, the operates with inductors of 47 μ H to 68 μ H. Where is inductor Ripple Current. Large value inductors lower ripple current and small value inductors result in high ripple currents. The DC current rating of the inductor should be at least equal to the maximum load current plus half the ripple current to prevent core saturation. In order to improve the efficiency, the series-wound resistor (DCR) of inductance should be smaller than 0.2 Ω .

The inductor value can be derived from the following equation:

$$L = \frac{V_{OUT} \times (V_{IN} - V_{OUT})}{V_{IN} \times \Delta I_L \times f_{OSC}}$$

Where: L: Inductance value

F: Oscillator frequency

ΔI is ripple current

4. Diode Selection

UTC **L3010** driver LED need a Schottky diode. If output current is 700mA or smaller then SS14 (D1N5819) is ok.

The average current through the diode is I_D :

$$I_D = (1-D) \cdot I_{LED}$$

I_{LED} is the current of LED

■ TYPICAL APPLICATION CIRCUIT

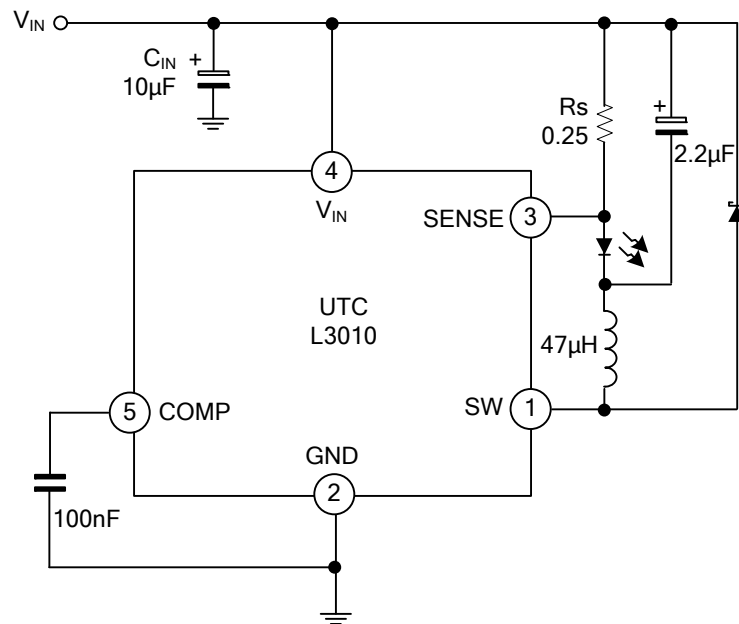

4.5~40V input voltage, 350mA output LED driver

Note: The circuit and parameters are reference only, please set the parameters of the real application circuit based on the real test .

TYPICAL CHARACTERISTICS

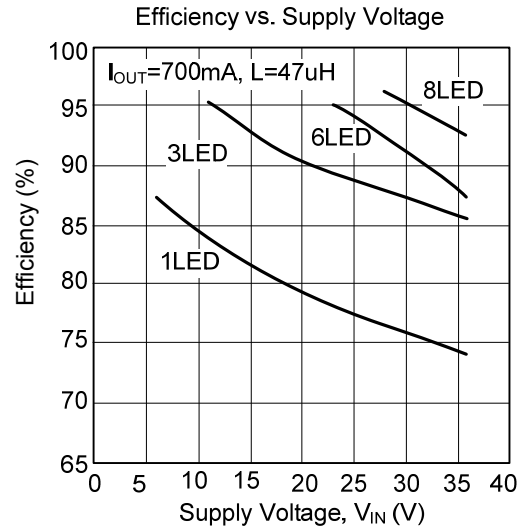
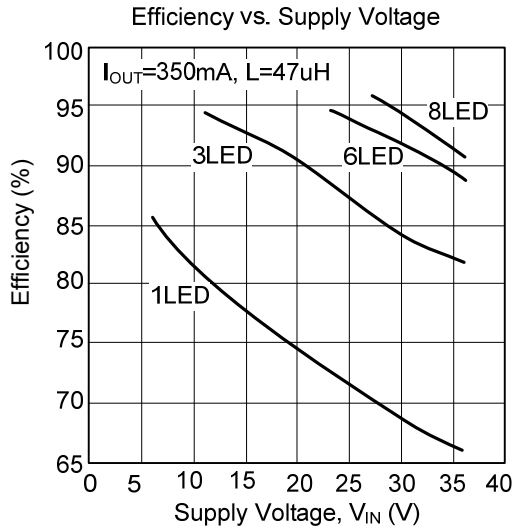

UTC assumes no responsibility for equipment failures that result from using products at values that exceed, even momentarily, rated values (such as maximum ratings, operating condition ranges, or other parameters) listed in products specifications of any and all UTC products described or contained herein. UTC products are not designed for use in life support appliances, devices or systems where malfunction of these products can be reasonably expected to result in personal injury. Reproduction in whole or in part is prohibited without the prior written consent of the copyright owner. The information presented in this document does not form part of any quotation or contract, is believed to be accurate and reliable and may be changed without notice.