

DESCRIPTION

The MT7200 is a continuous mode inductive step-down converter, designed for driving single or multiple series connected LEDs efficiently from a voltage source higher than the LED voltage. The device operates from an input supply between 7~40V and provides an externally adjustable output current of up to 350mA. Depending upon supply voltage and external components, this can provide up to 8 watts of output power.

The MT7200 includes the output switch and a high-side output current sensing circuit, which uses an external resistor to set the nominal average output current.

FEATURES

- Pass 4KV ESD test
- Simple low parts count
- 350mA output current
- Single pin on/off and brightness control using DC voltage or PWM
- Internal PWM filter
- Soft-start
- High efficiency (up to 97%)
- Wide input voltage range: 7V to 40V
- Output shutdown
- Up to 1MHz switching frequency
- Inherent open-circuit LED protection
- Typical 4% output current accuracy

APPLICATION CIRCUIT

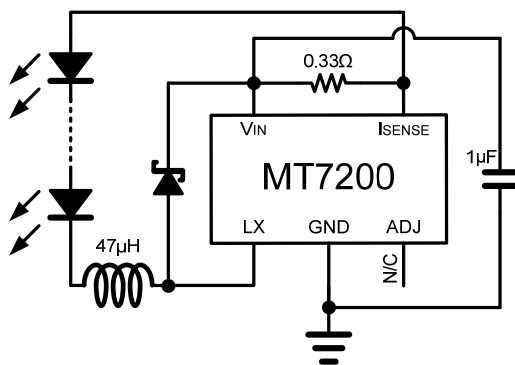

Output current can be adjusted above, or below the set value, by applying an external control signal to the 'ADJ' pin.

The ADJ pin will accept either a DC voltage or a PWM waveform. Depending upon the control frequency, this will provide either a continuous or a gated output current. The PWM filter components are contained within the chip.

The PWM filter provides a soft-start feature by controlling the rise of input/output current. The soft-start time can be increased using an external capacitor from the ADJ pin to ground. Applying a voltage of 0.2V or lower to the ADJ pin turns the output off and switches the device into a low current standby state.

The device is assembled in a SOT23-5/SOT89-5 pin package.

APPLICATION

- Low voltage halogen replacement LEDs
- Automotive lighting
- Low voltage industrial lighting
- LED back-up lighting
- Illuminated signs

PIN CONFIGURATION

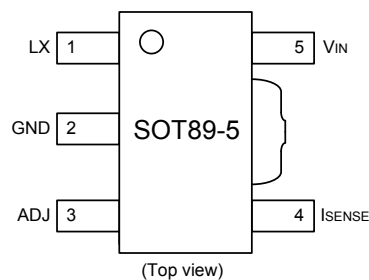
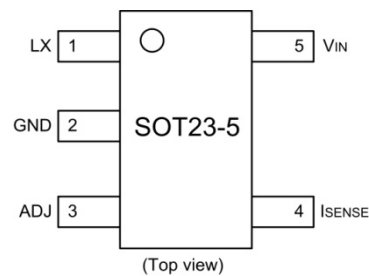

Absolute maximum ratings (voltages to GND unless otherwise stated)

Input voltage (V_{IN})	-0.3V to +40V
I _{SENSE} voltage (V_{SENSE})	+0.3V to -5V (measured with respect to V_{IN})
LX output voltage (V_{LX})	-0.3V to +40V
Adjust pin input voltage (V_{ADJ})	-0.3V to +6V
Switch output current (I_{LX})	500mA
Power dissipation (P_{tot})	450mW
Operating temperature (T_{OP})	-40 to 105°C
Storage temperature (T_{ST})	-55 to 150°C
Junction temperature (T_{jMAX})	150°C

Thermal resistance

Junction to ambient ($R_{\theta JA}$)	200°C/W
---	---------

Pin description

Name	Pin No.	Description
LX	1	Drain of Power MOS switch
GND	2	Ground
ADJ	3	Multi-function On/Off and brightness control pin: <ul style="list-style-type: none"> • Leave floating for normal operation. ($V_{ADJ}=V_{REF}=1.20$ giving nominal average output current $I_{OUTnom}=0.1/R_S$) • Drive to voltage below 0.2V to turn off output current • Drive with DC voltage ($0.3V < V_{ADJ} < 2.5V$) to adjust output current from 25% to 200% of I_{OUTnom} • Drive with PWM signal from open-collector or open-drain transistor, to adjust output current. Adjustment range 25% to 100% of I_{OUTnom} for $f > 10kHz$ and 1% to 100% of I_{OUTnom} for $f < 500Hz$ • Connect a capacitor from this pin to ground to increase soft-start time. (Default soft-start time=0.8ms. Additional soft-start time is approx. 0.8ms/nF)
I _{SENSE}	4	Connect resistor R_S from this pin to V_{IN} to define nominal average output current $I_{OUTnom}=0.1/R_S$ (Note: $R_{SMIN}=0.27\Omega$ with ADJ pin open-circuit)
V_{IN}	5	Input voltage (7V to 30V). Decouple to ground with 1 μ F or higher X7R ceramic capacitor close to device

Ordering information

Device	Reel size(mm)	Reel width(mm)	Quantity per reel	Device mark
MT7200	180	8	3,000	MT7200

Electrical characteristics

(test conditions: $V_{IN}=12V$, $T_{amb}=25^{\circ}C$ unless otherwise stated)

Symbol	Parameter	Conditions	Min	Typ	Max	Unit
V_{IN}	Input Voltage		7		40	V
V_{SU}	Internal regulator start-up threshold	V_{IN} rising		4.8		V
I_{INQoff}	Quiescent supply current with output off	ADJ pin grounded		45		μA
I_{INQon}	Quiescent supply current with output on	ADJ pin floating $f=250kHz$		250	500	μA
V_{SENSE}	Mean current sense threshold voltage (defines LED current setting accuracy)	Measured on I_{SENSE} pin with respect to V_{IN} $V_{ADJ}=1.25V$	95	100	105	mV
$V_{SENSEHYS}$	Sense threshold hysteresis			± 15		%
I_{SENSE}	I_{SENSE} pin input current	$V_{SENSE}=V_{IN}-0.1$		1.25	10	μA
V_{REF}	Internal reference voltage	Measured at ADJ pin with pin floating		1.20		V
$\Delta V_{REF}/\Delta T$	Temperature coefficient of V_{REF}			50		ppm/ $^{\circ}C$
V_{ADJ}	External control voltage range on ADJ pin for dc brightness control		0.3		2.5	V
V_{ADJoff}	DC voltage on ADJ pin to switch device from on state to off state	V_{ADJ} falling		0.2		V
V_{ADJon}	DC voltage on ADJ pin to switch device from off state to on state	V_{ADJ} rising		0.25		V
R_{ADJ}	Resistance between ADJ pin and V_{REF}		170	200	260	k Ω
I_{LXmean}	Continuous LX switch current				0.37	A
R_{LX}	LX switch 'On' resistance			1.5	2	Ω
$I_{LX(leak)}$	LX switch leakage current				1	μA
$DPWM(LF)$	Duty cycle range of PWM signal applied to ADJ pin during low frequency PWM dimming mode	Frequency < 500Hz Amplitude = V_{REF} Measured on ADJ pin	0.01		1	
	Brightness control range			100:1		

DPWM(HF)	Duty cycle range of PWM signal applied to ADJ pin during high frequency PWM dimming mode	Frequency > 10kHz Amplitude = V_{REF} Measured on ADJ pin	0.16		1	
	Brightness control range			5:1		
T _{SS}	Soft start time	Time taken for output current to reach 90% of final value after voltage on ADJ pin has risen above 0.3V		800		μ s
f _{LX}	Operating frequency	ADJ pin floating L=100 μ H I _{OUT} =350mA@V _{LED} =3.4V Driving 1 LED		350		kHz
T _{ONmin}	Minimum 'ON' time	LX switch 'ON'	200			ns
T _{OFFmin}	Minimum 'OFF' time	LX switch 'OFF'	200			ns
f _{LXmax}	Recommended maximum operating frequency				1.1	MHz
D _{LX}	Recommended duty cycle range of output switch at f _{LXmax}		0.3		0.7	
T _{PD}	Internal comparator propagation delay			50		ns

Block diagram

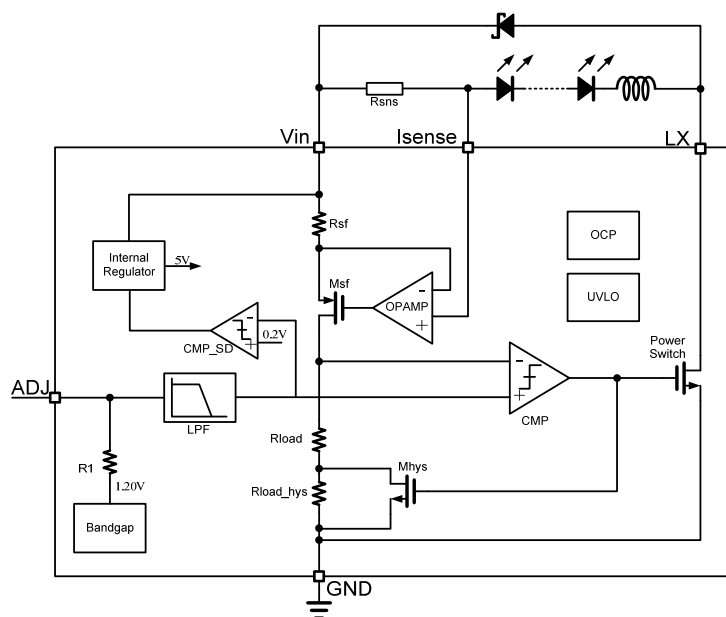

Typical operating conditions

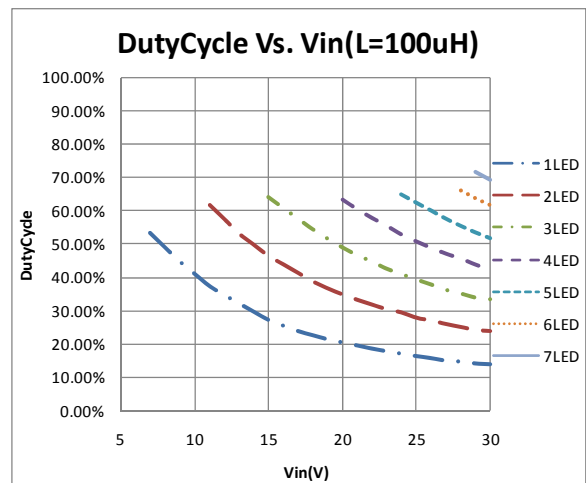
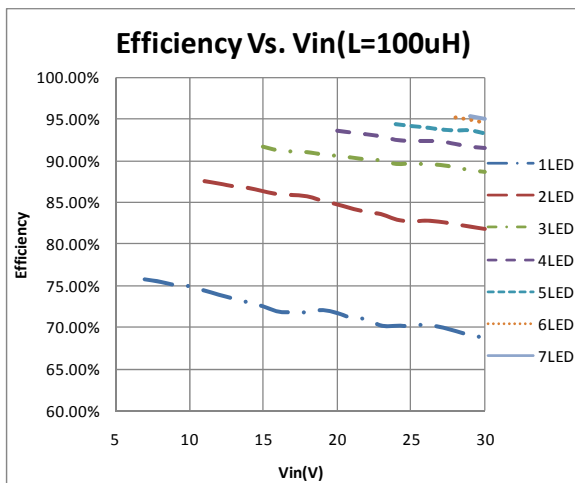
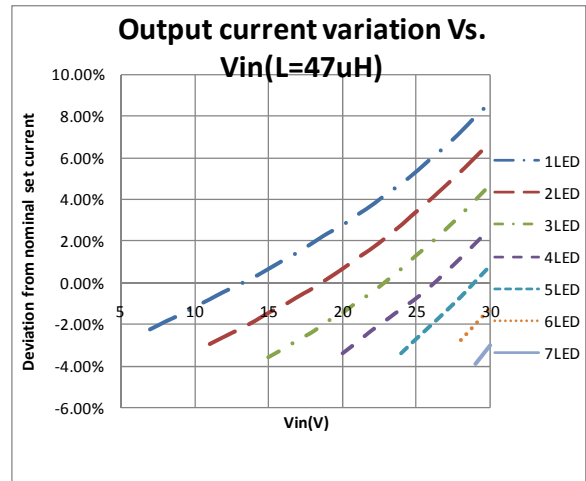
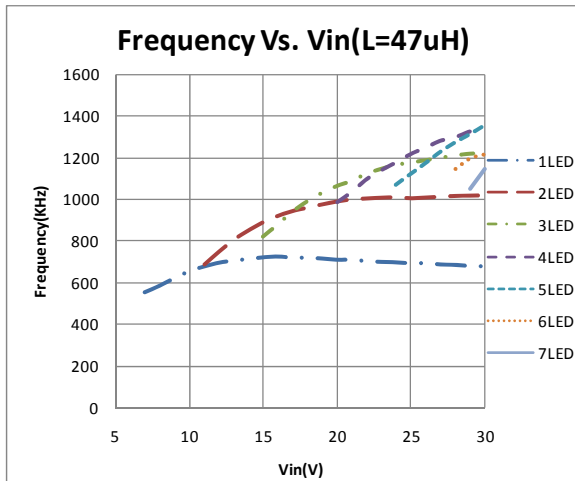
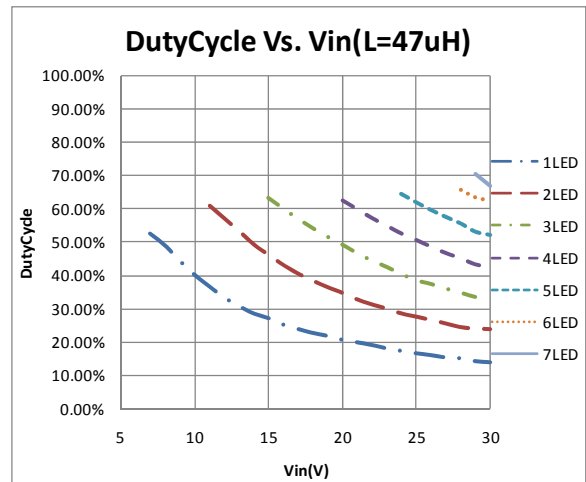
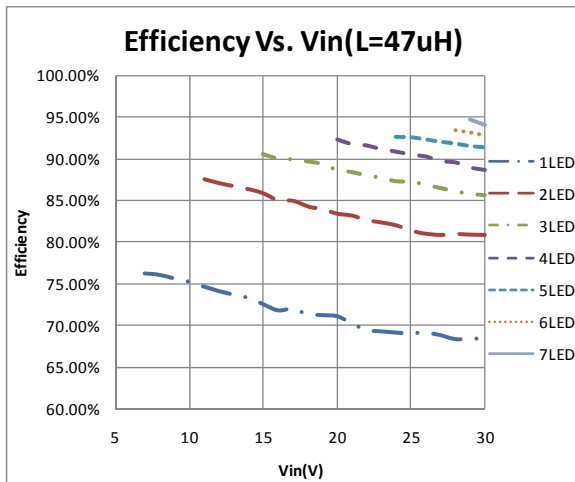

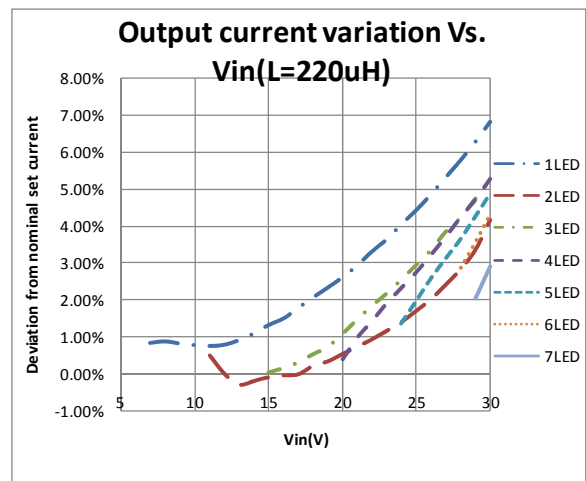
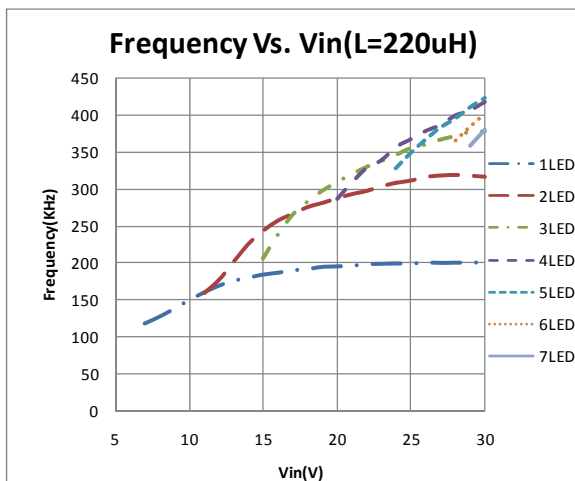
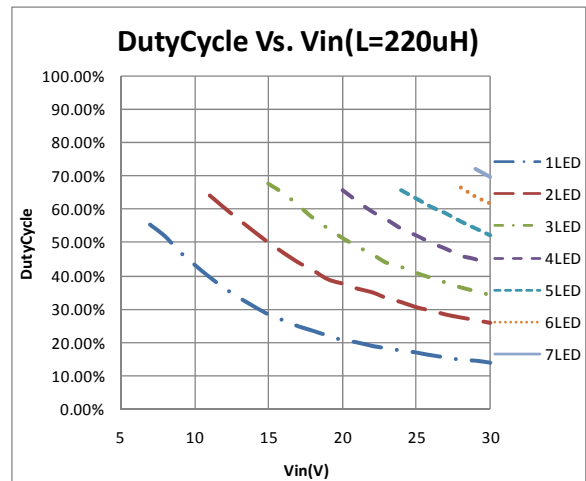
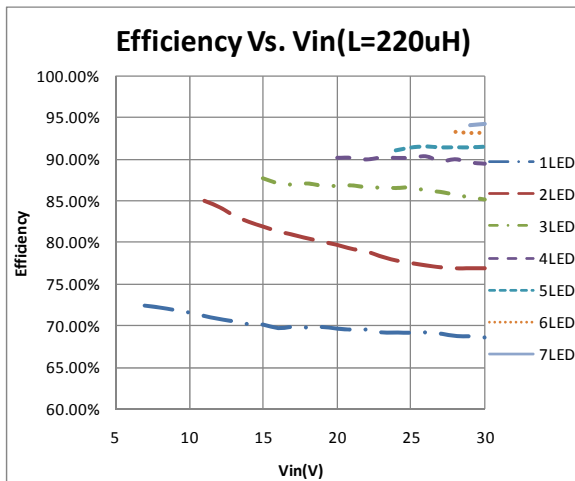
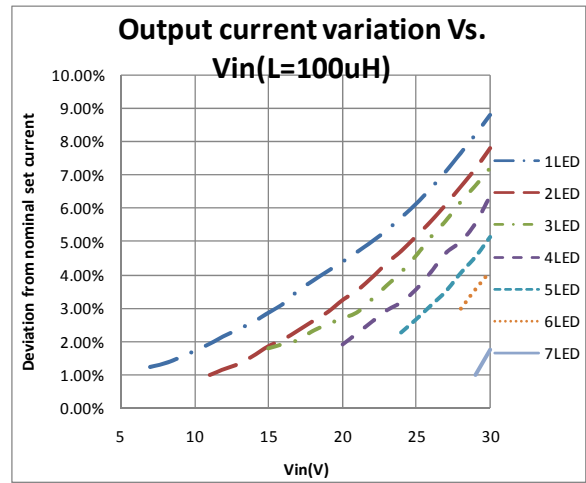
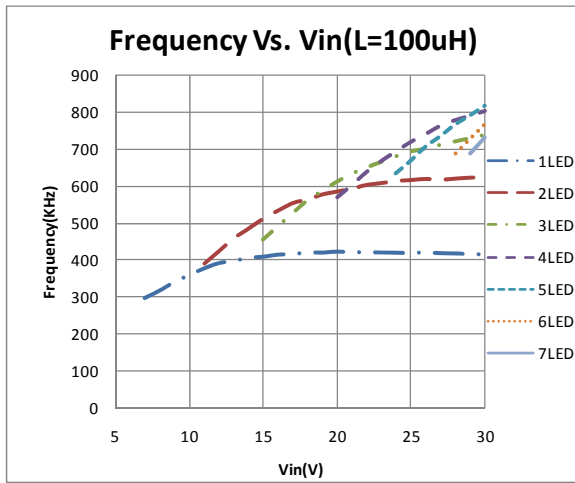

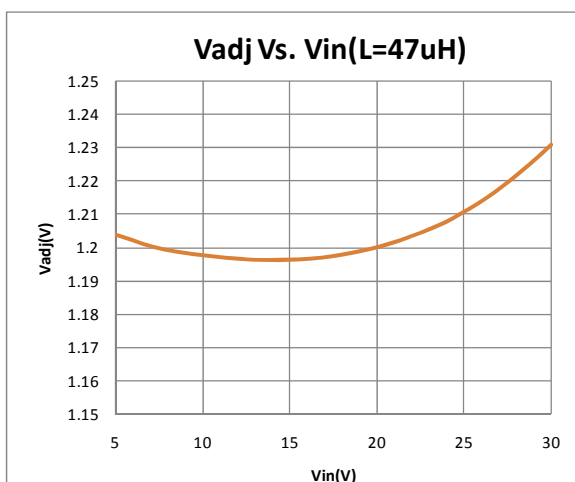
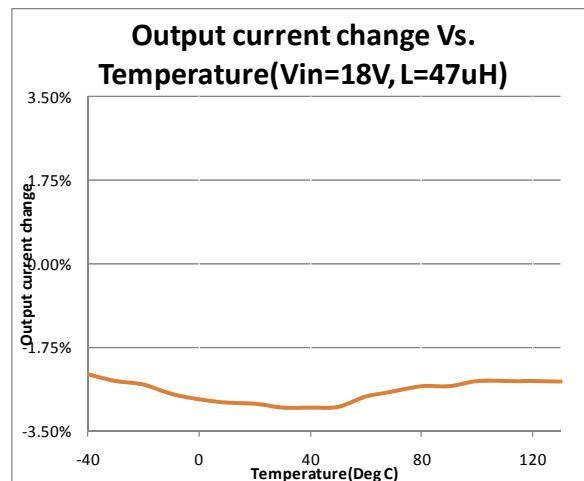
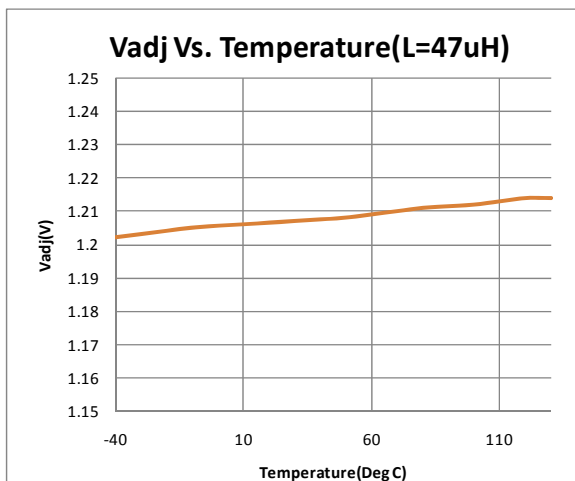
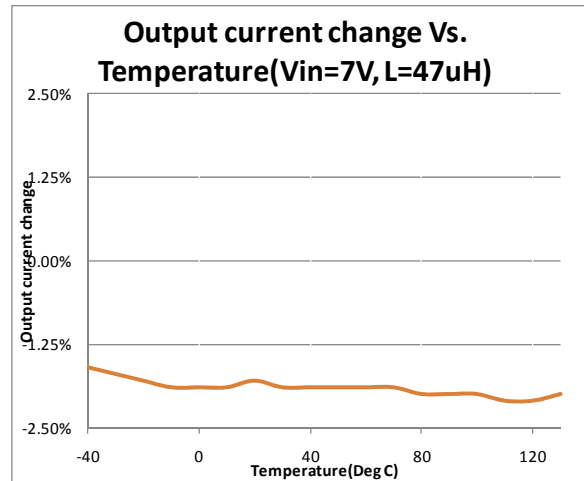
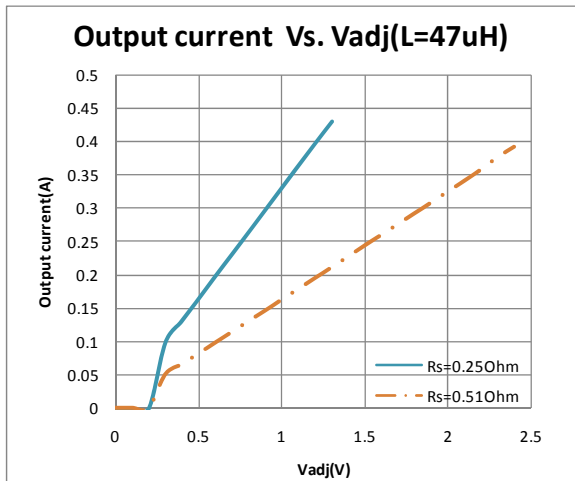

Application notes

Setting nominal average output current with external resistor R_s

The nominal average output current in the LED(s) is determined by the value of the external current sense resistor (R_s) connected between V_{IN} and I_{SENSE} and is given by:

$$I_{OUTnom} = 0.1/R_s \text{ [for } R_s > 0.27 \text{]}$$

The table below gives values of nominal average output current for several preferred values of current setting resistor (R_s) in the typical application circuit shown on page 1:

$R_s(\Omega)$	Nominal average output current (mA)
0.27	370
0.3	333
0.33	300
0.39	256

The above values assume that the ADJ pin is floating and at a nominal voltage of V_{REF} .

Note that $R_s=0.27\Omega$ is the minimum allowed value of sense resistor under these conditions to maintain switch current below the specified maximum value.

It is possible to use different values of R_s if the ADJ pin is driven from an external voltage.

Output current adjustment by external DC control voltage

The ADJ pin can be driven by an external dc voltage (V_{ADJ}), as shown, to adjust the output current to a value above or below the nominal average value defined by R_s .

The nominal average output current in this case is given by:

$$I_{OUTdc} = V_{ADJ}/1.2/R_s \text{ [for } 0.3 < V_{ADJ} < 2.5V \text{]}$$

Note that 100% brightness setting corresponds to $V_{ADJ}=V_{REF}$. When driving the ADJ pin above 1.2V, R_s must be increased in proportion to prevent I_{OUTdc} exceeding 370mA maximum. The input impedance of the

ADJ pin is $200k \Omega \pm 25\%$.

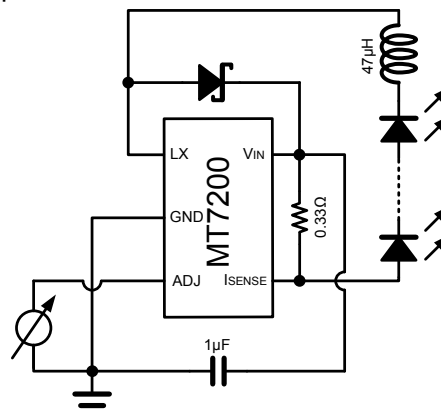

Output current adjustment by PWM control

1. Directly driving ADJ input

A Pulse Width Modulated (PWM) signal with duty cycle D_{PWM} can be applied to the ADJ pin, as shown below, to adjust the output current to a value above or below the nominal average value set by resistor R_s :

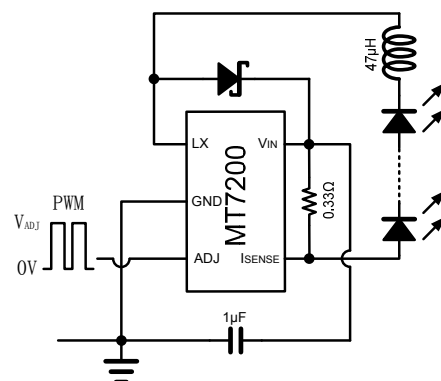

2. Driving the ADJ input via open collector transistor

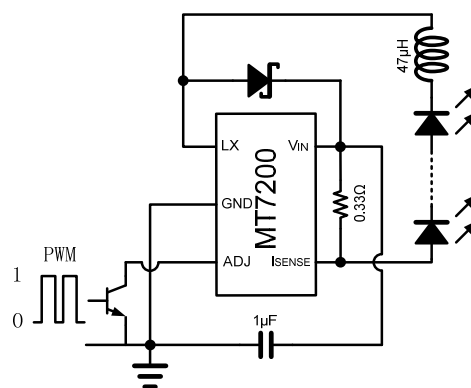

The recommended method of driving the ADJ pin and controlling the amplitude of the PWM waveform is to use a small NPN switching transistor as shown.

3. Driving the ADJ from a microcontroller

Another possibility is to drive the device from the open drain output of a microcontroller. The diagram below shows one method of doing this:

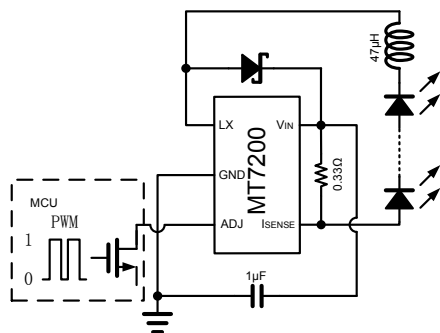

Shutdown mode

Taking the ADJ pin to a voltage below 0.2V for more than approximately 100µs, will turn off the output and supply current will fall to a low standby level of 50µA nominal.

Note that the ADJ pin is not a logic input.

Taking the ADJ pin to a voltage above V_{REF} will increase output current above the 100% nominal average value.

Inherent open-circuit LED protection

If the connection to the LED(s) is open-circuited, the coil is isolated from the LX pin of the chip, so the device will not be damaged, unlike in many boost converters, where the back EMF may damage the internal switch by forcing the drain above its breakdown voltage.

Capacitor selection

A low ESR capacitor should be used for input decoupling, as the ESR of this capacitor

appears in series with the supply source impedance and lowers overall efficiency. This capacitor has to supply the relatively high peak current to the coil and smooth the current ripple on the input supply. A minimum value of 1µF is acceptable if the input source is close to the device, but higher values will improve performance at lower input voltages, especially when the source impedance is high. The input capacitor should be placed as close as possible to the IC.

Inductor selection

Recommended inductor values for the MT7200 are in the range 27µH to 100µH. Higher values of inductance are recommended at higher supply voltages in order to minimize errors due to switching delays, which result in increased ripple and lower efficiency. Higher values of inductance also result in a smaller change in output current over the supply voltage range. (See graphs). The inductor should be mounted as close to the device as possible with low resistance connections to the LX and V_{IN} pins. The chosen coil should have a saturation current higher than the peak output current and a continuous current rating above the required mean output current.

The inductor value should be chosen to maintain operating duty cycle and switch 'on'/'off' times within the specified limits over the supply voltage and load current range. The following equations can be used as a guide:

LX Switch 'On' time

$$T_{ON} = \frac{L\Delta I}{V_{IN} - V_{LED} - I_{avg}(R_S + r_L + R_{LX})}$$

Note: $T_{ONmin} > 200ns$

LX Switch 'Off' time

$$T_{OFF} = \frac{L\Delta I}{V_D + V_{LED} + I_{avg}(R_S + r_L)}$$

Note: $T_{OFFmin} > 200ns$

Where:

L is the coil inductance (H)

r_L is the coil resistance (Ω)

I_{avg} is the required LED current (A)

ΔI is the coil peak-peak ripple current (A)
{internally set to $0.3 \times I_{avg}$ }

V_{IN} is the supply voltage (V)

V_{LED} is the total LED forward voltage (V)

R_{LX} is the switch resistance (Ω)

V_D is the diode forward voltage at the required load current (V)

Diode selection

It is important to select parts with a peak current rating above the peak coil current and a continuous current rating higher than the maximum output load current. It is very important to consider the reverse leakage of the diode when operating above 85°C. Excess leakage will increase the power dissipation in the device.

Reducing output ripple

Peak to peak ripple current in the LED can be reduced, if required, by shunting a capacitor C_{led} across the LED(s). A value of 1 μ F will reduce nominal ripple current by a factor three (approx.). Proportionally lower ripple can be achieved with higher capacitor values. Note that the capacitor will not affect operating frequency or efficiency, but it will increase start-up delay, by reducing the rate of rise of LED voltage.

Operation at low supply voltage

The internal regulator disables the drive to the switch until the supply has risen above the startup threshold (V_{su}). Above this threshold,

the device will start to operate. However, with the supply voltage below the specified minimum value, the switch duty cycle will be high and the device power dissipation will be at a maximum. Care should be taken to avoid operating the device under such conditions in the application, in order to minimize the risk of exceeding the maximum allowed die temperature.

Note that when driving loads of two or more LEDs, the forward drop will normally be sufficient to prevent the device from switching below approximately 6V. This will minimize the risk of damage to the device.

Layout considerations

LX pin

The LX pin of the device is a fast switching node, so PCB tracks should be kept as short as possible. To minimize ground 'bounce', the ground pin of the device should be soldered directly to the ground plane.

Coil and decoupling capacitors and current sense resistor

It is particularly important to mount the coil and the input decoupling capacitor as close to the device pins as possible to minimize parasitic resistance and inductance, which will degrade efficiency. It is also important to minimize any track resistance in series with current sense resistor R_s . It's best to connect V_{IN} directly to one end of R_s and I_{sense} directly to the opposite end of R_s with no other currents flowing in these tracks. It is important that the cathode current of the Schottky diode does not flow in a track between R_s and V_{IN} as this may give an apparent higher measure of current than is actual because of track resistance.

ADJ pin

The ADJ pin is a high impedance input for voltages up to 1.35V so, when left floating, PCB tracks to this pin should be as short as possible to reduce noise pickup. A 100nF capacitor from the ADJ pin to ground will reduce frequency modulation of the output under these conditions. An additional RC low pass filter (10k Ω /100 μ F) can also be used when driving the ADJ pin from an external circuit. This LPF will provide filtering for low frequency noise and provide protection against high voltage transients.

High voltage tracks

Avoid running any high voltage tracks close to the ADJ pin, to reduce the risk of leakage pin currents due to board contamination. The ADJ is soft-clamped for voltages above 1.35V to desensitize it to leakage that might raise the ADJ pin voltage and cause excessive output current. However, a ground ring placed around the ADJ pin is recommended to minimize changes in output current under these conditions.

Evaluation board

The MT7200 evaluation boards are available on request.

Demo Board

SCHEMATIC

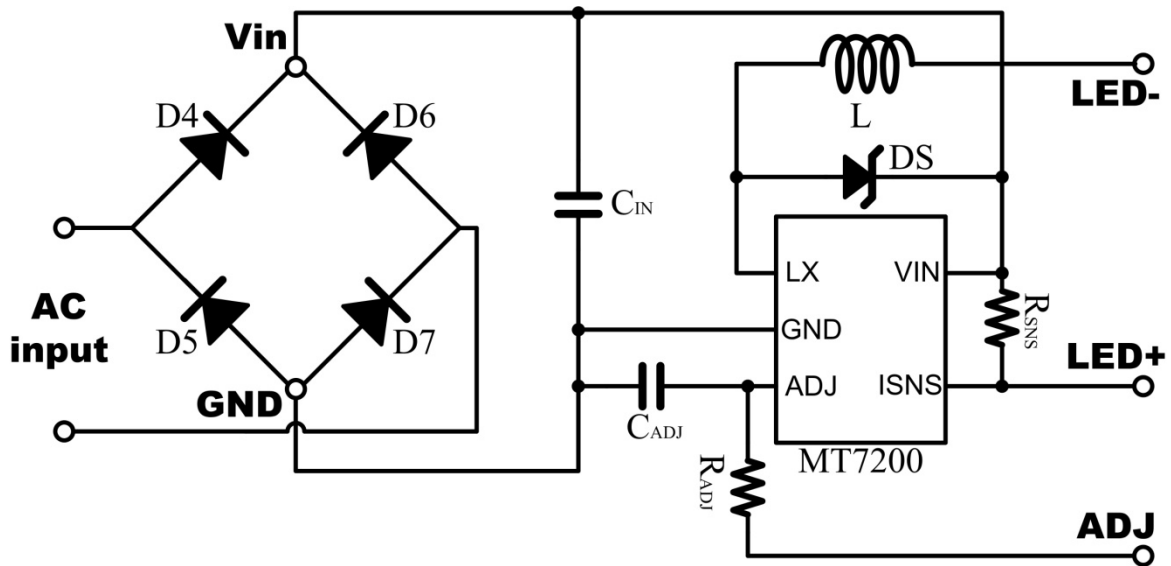

PARTS LIST

Qty.	Reference	Description	Size
4	D4,D5,D6,D7	Schottky diode, DFSL240	PowerDI
1	DS	Schottky diode, BAT54C	SOT23-3
1	CIN	Input capacitor, 100uF (AC), 1uF (DC)	
1	CADJ	Dimming capacitor	0603
1	RADJ	Dimming resistor	0603
1	L	Loop inductor, typically 47uH	
1	RSNS	Current sensing resistor	0603
1	MT7200	IC, MT7200, 350mA LED driver	SOT23-5/SOT89-5

PHOTO

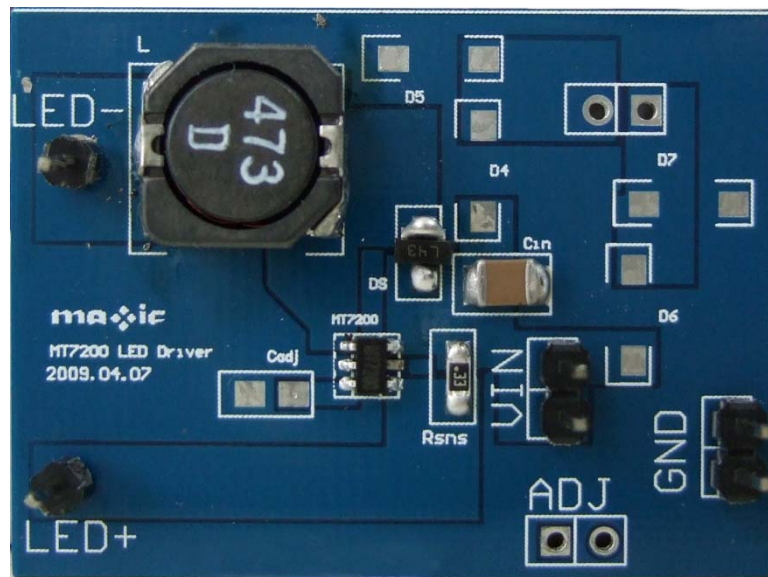

Package information

SOT23-5

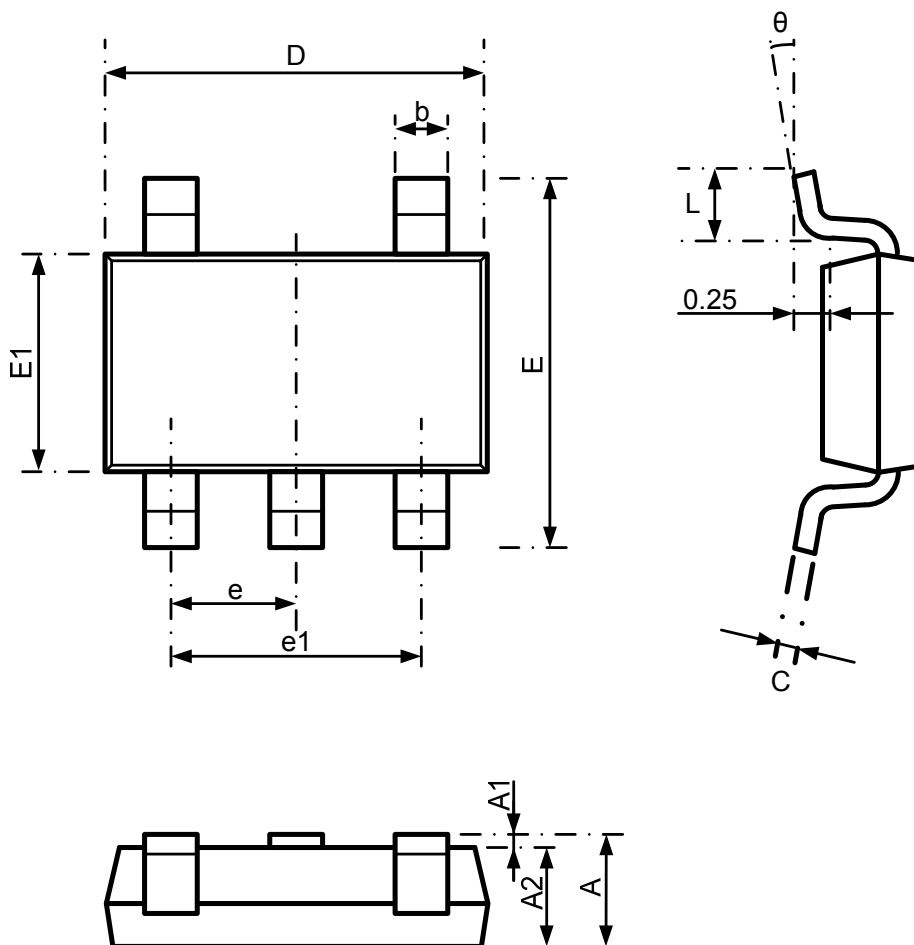

Symbol	Dimensions in millimeters		Dimensions in inches	
	Min	Max	Min	Max
A	1.050	1.250	0.041	0.049
A1	0.000	0.100	0.000	0.004
A2	1.050	1.150	0.041	0.045
b	0.300	0.500	0.012	0.020
c	0.100	0.200	0.004	0.008
D	2.820	3.020	0.111	0.119
E	1.500	1.700	0.059	0.067
E1	2.650	2.950	0.104	0.116
e	0.950(BSC)		0.037(BSC)	
e1	1.800	2.000	0.071	0.079
L	0.300	0.600	0.012	0.024
θ	0°	8°	0°	8°

SOT89-5

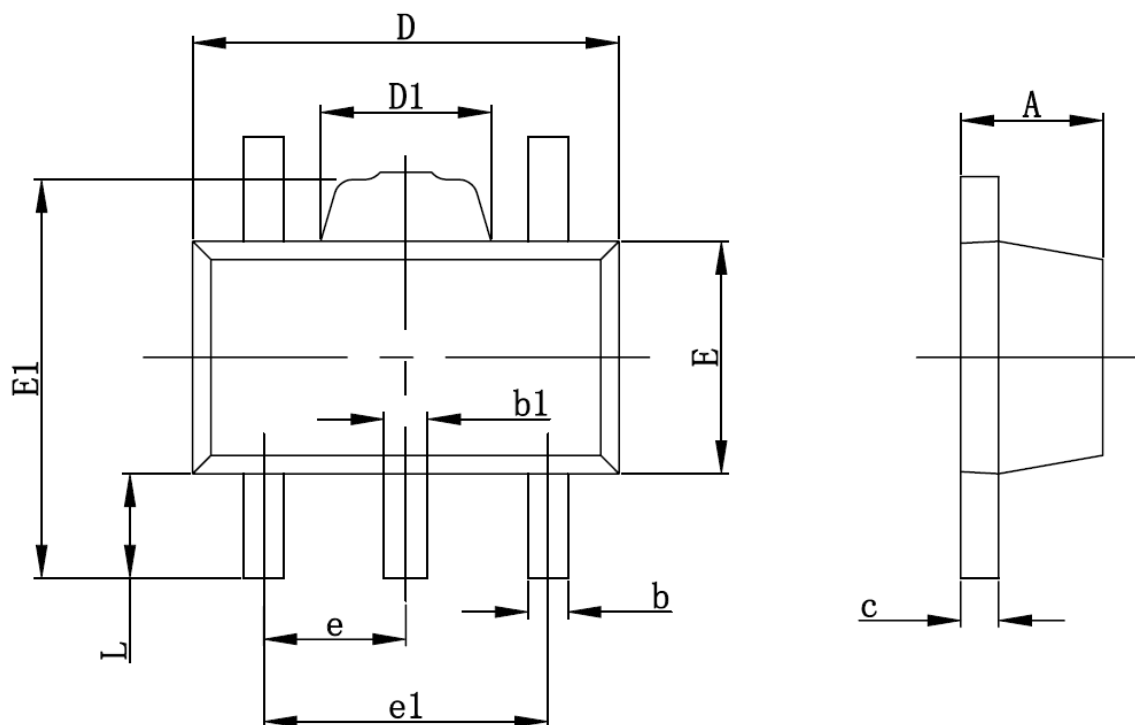

Symbol	Dimensions in millimeters		Dimensions in inches	
	Min	Max	Min	Max
A	1.400	1.600	0.055	0.063
b	0.320	0.520	0.013	0.020
b1	0.360	0.560	0.014	0.022
c	0.350	0.440	0.014	0.017
D	4.400	4.600	0.173	0.181
D1	1.400	1.800	0.055	0.071
E	2.300	2.600	0.091	0.102
E1	3.940	4.250	0.155	0.167
e	1.500TYP		0.060TYP	
e1	2.900	3.100	0.114	0.122
L	0.900	1.100	0.035	0.043



Maxic Technology Corporation(Hong Kong office)

Rm D1, 7th floor, JianAn Commercial Building,
No. 49-51, Suhong Str., Sheung Wan, Hong Kong

Maxic Technology Corporation (Beijing Office)

Room 911, Building 3, Zi Jin Digital Garden, Hai Dian District, Beijing, China, 100190

Tel: 86-10-62662828

Fax: 86-10-62662951

Web: www.maxictech.com

E-mail: sales@maxictech.com, info@maxictech.com