

SPECIFICATION

FOR LCD MODULE

MODEL NO:	TM12864H6CCOWA
CUSTOMER:	
CUSTOMER P/N.	
VERSION	V1.0
CUSTOMER APPROVED	

- Preliminary specification
- Final specification

PREPARED BY	CHECKED BY	VERIFIED BY QA DEPT.	APPROVED BY

TIANMA MICRO-ELECTRONICS CO., LTD

Address: 8F, 64th Building, Jinlong, Majialong Industrial Area, Nanshan District, Shenzhen, China

Tel: +86-755-26094288

Fax: +86-755-86225774

Web: www.tianma.cn www.tianma.com

TIANMA MICROELECTRONICS CO., LTD

Company confidential. Duplication or disclosure prohibited. All rights reserved

RoHS

TABLE OF CONTENTS

	Page
1. Description -----	3
2. Features -----	3
3. Absolute maximum ratings -----	4
4. Mechanical Characteristics-----	4
5. Circuit -----	6
6. Interface description -----	8
7. Instruction Code & Timing characteristics -----	9
8. Electrical Specifications-----	15
9. LED backlight characteristics-----	15
10. Optical Characteristics-----	16
11. Reliability-----	20
12. Package -----	22
13. Quality level -----	23
14. Precautions for Use of LCD Modules-----	29
15. LCD Module Part Numbering System -----	31

1 Description

The TM12864H6CCOWA, Graphics LCM unit consists of 128 (segment) x 64 (common) dots dot-matrix LCD panel, NT75451 is a single-chip dot matrix LCD driver that can be connected directly to a microprocessor bus.

- ◆ Wide Operating temperature.
- ◆ Requirements on environmental protection: RoHS.

2 Features

Item	Contents
LCD type	FSTN
	Positive
LCD Duty	1/65
LCD Bias	1/9
Polarizer	Transflective
LCD background color	White
Segment color	Blue-black
Backlighting	LED
Backlighting type	Edge
Backlighting color	White
Backlighting drive	I=15mA,V=3.2V(TYP.)
View direction	6:00
Operating temperature	-20℃~70℃
Storage temperature	-40℃~80℃
Controller	NT75451
Technology	COG
Power supply	VDD=3.0V
Data Transfer	Parallel

Notes:

- Color tone can slightly change with temperature and driving voltage.
- Color tone will be changed by backlight.

3 Absolute maximum ratings

(Without LED backlighting ,Ta=25°C)

Parameter	Symbol	Min	Max	Unit	Remark
Logic circuit supply voltage	V _{DD}	-0.3	+4.0	V	
LCD driving voltage	V _{LCD}	-0.3	+15.0	V	
Operating temperature range	Top	-20	+70	°C	No Condensatio n
Storage temperature range	Tst	-40	+80	°C	

Note :

- LCD operating voltage $V_{LCD}=V_0 - V_{SS}$, which is the voltage of the capacitor of C1.
- If the module is above these absolute maximum ratings. It may become permanently damaged.
- $V_{DD} > V_{SS}$ must be maintained.

4 Mechanical Characteristics

4.1 Mechanical features

Parameter	Standard Value	Unit
Display type	Graphics module	--
Character size(W×H)	--	mm
Number of dots/characters (W×H)	128 x 64	--
View area (W×H)	50.00 x 25.00	mm
Active Area (W×H)	46.05 x 23.01	mm
Dot Size (W×H)	0.33 x 0.33	mm
Dot Pitch (W×H)	0.36 x 0.36	mm
Module size(W×H×D)	74.00 x39.00 x 8.00(MAX)	mm
Module outline dimensions	Refer to page 5-“Mechanical drawing”	--

NOTE: Include the length of the PCB

4.2 Mechanical drawing.

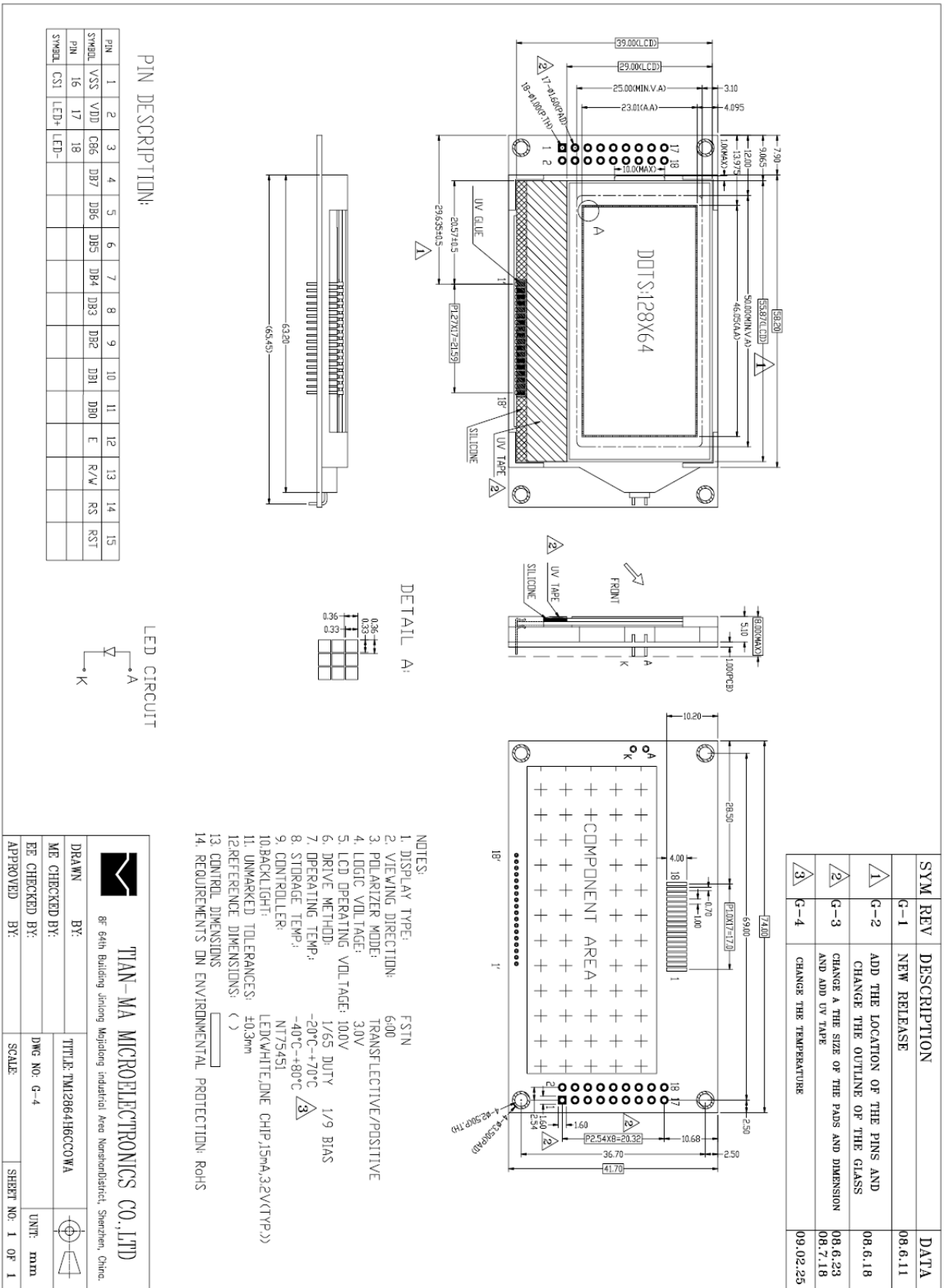

5 Circuit

5.1 Block Diagram

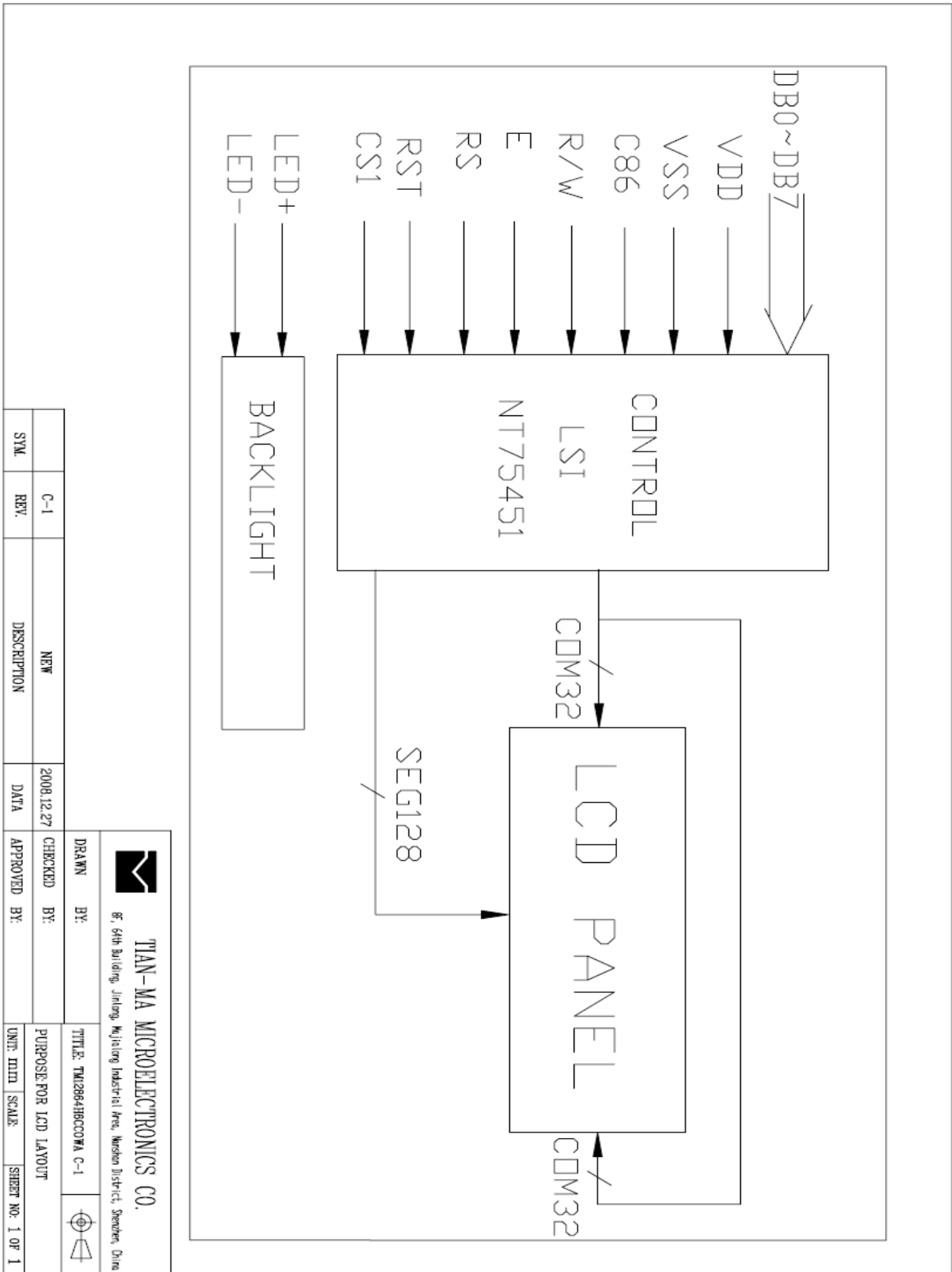

5.2 Recommend interface circuit

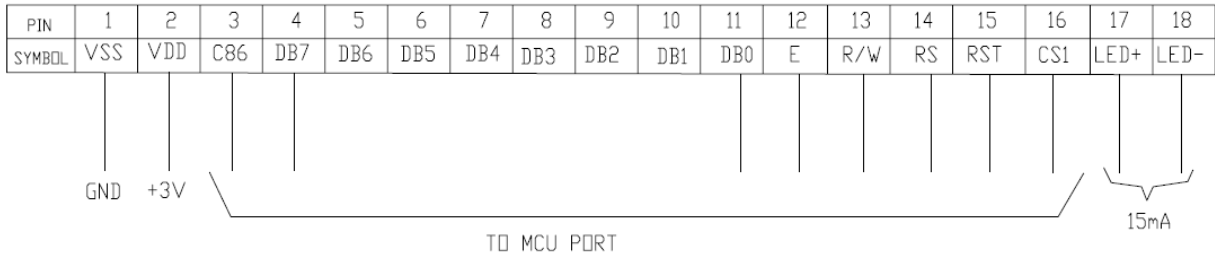

NOTE:

1.VDD=+3.0V;

6 Interface description .

Pin No.	Symbol	I/O	Description
1	VSS	0V	Ground
2	VDD	3.0V	Power supply voltage for LCD logic
3	C86	I	6800/8080 select
4	DB7	I/O	Data bit
5	DB6	I/O	Data bit
6	DB5	I/O	Data bit
7	DB4	I/O	Data bit
8	DB3	I/O	Data bit
9	DB2	I/O	Data bit
10	DB1	I/O	Data bit
11	DB0	I/O	Data bit
12	E	I	Read/write enable signal
13	R/W	I	Read/write signal
14	RS	I	Command/data select signal
15	RST	I	Reset signal
16	CS1	I	Chip select
17	LED+	I	Power supply voltage for LED+
18	LED-	I	Power supply voltage for LED-

7 Instruction Code & Timing characteristics

7.1 COMMAND

The module TM12864H6CCOWA include the controller-NT75451. The table below lists the types of commands, including the code of each command. more details refer to NT75451 data sheet please.

Table.1 INSTRUCTION

Command	A0	/RD	/WR	Code								Hex	Function
				D7	D6	D5	D4	D3	D2	D1	D0		
(1) Display OFF	0	1	0	1	0	1	0	1	1	1	0	AEh AFh	Turn on LCD panel when high, and turn off when low
(2) Display Start Line Set	0	1	0	0	1	Display Start Address					40h to 7Fh	Specifies RAM display line for COM0	
(3) Page Address Set	0	1	0	1	0	1	1	Page Address				B0h to B8h	Set the display data RAM page in Page Address register
(4) Column Address Set	0	1	0	0	0	0	1	Higher Column Address				00h to 18h	Set 4 higher bits and 4 lower bits of column address of display data RAM in register
	0	1	0	0	0	0	0	Lower Column Address					
(5) Read Status	0	0	1	Status				0	0	0	0	XX	Reads the status information
(6) Write Display Data	1	1	0	Write Data								XX	Write data in display data RAM
(7) Read Display Data	1	0	1	Read Data								XX	Read data from display data RAM
(8) ADC Select	0	1	0	1	0	1	0	0	0	0	0	A0h A1h	Set the display data RAM address SEG output correspondence
(9) Normal/Reverse Display	0	1	0	1	0	1	0	0	1	1	0	A6h A7h	Normal indication when low, but full indication when high
(10) Entire Display ON/OFF	0	1	0	1	0	1	0	0	1	0	0	A4h A5h	Select normal display (0) or entire display on
(11) LCD Bias Set	0	1	0	1	0	1	0	0	0	1	0	A2h A3h	Sets LCD driving voltage bias ratio
(12) Read-Modify-Write	0	1	0	1	1	1	0	0	0	0	0	E0h	Increments column address counter during each write
(13) End	0	1	0	1	1	1	0	1	1	1	0	EEh	Releases the Read-Modify-Write
(14) Reset	0	1	0	1	1	1	0	0	0	1	0	E2h	Resets internal functions
(15) Common Output Mode Select	0	1	0	1	1	0	0	0	*	*	*	C0h to CFh	Select COM output scan direction *: invalid data
(16) Power Control Set	0	1	0	0	0	1	0	1	Operation Status			28h to 2Fh	Select the power circuit operation mode
(17) V0 Voltage Regulator Internal Resistor ratio Set	0	1	0	0	0	1	0	0	Resistor Ratio			20h to 27h	Select internal resistor ratio Rb/Ra mode
(18) Electronic Volume mode Set	0	1	0	1	0	0	0	0	0	0	1	81h	
Electronic Volume Register Set	0	1	0	*	*	Electronic Control Value					XX	Sets the V0 output voltage electronic volume register	
(19) Set Static indicator ON/OFF	0	1	0	1	0	1	0	1	1	0	0	ACh ADh	Sets static indicator ON/OFF 0: OFF, 1: ON
Set Static Indicator Register	0	1	0	*	*	*	*	*	*	Mode		XX	Sets the flash mode
(20) Power Save	0	1	0	-	-	-	-	-	-	-	-	-	Compound command of Display OFF and Entire Display ON
(21) NOP	0	1	0	1	1	1	0	0	0	1	1	E3h	Command for non-operation

Command	A0	/RD	/WR	Code								Hex	Function	
				D7	D6	D5	D4	D3	D2	D1	D0			
(22)Oscillation Frequency Select	0	1	0	1	1	1	0	0	1	0	0	1	E4h E5h	Select the oscillation frequency
(23)Partial Display mode Set	0	1	0	1	0	0	0	0	0	1	0	1	82h 83h	Enter/Release the partial display mode
(24)Partial Display Duty Set	0	1	0	0	0	1	1	0	Duty Ratio		30h 37h	Sets the LCD duty ratio for partial display mode		
(25)Partial Display Bias Set	0	1	0	0	0	1	1	1	Bias Ratio		38h 3Fh	Sets the LCD bias ratio for partial display mode		
(26)Partial Start Line Set	0	1	0	1	1	0	1	0	0	1	1	D3h	Enter Partial Start Line Set	
Partial Start Line Set	0	1	0	1	1	Partial Start Line					XX	Sets the LCD Number of partial display start line		
(27)N-Line Inversion Set	0	1	0	1	0	0	0	0	1	0	1	85h	Enter N-Line inversion	
Number of Line Set	0	1	0	*	*	*	Number of Line				XX	Sets the number of line used for N-Line inversion		
(28)N-Line Inversion Release	0	1	0	1	0	0	0	0	1	0	0	84h	Exit N-Line Inversion	
(29)DC/DC Multiple Set	0	1	0	1	0	0	0	1	0	0	1	89h	Select the step-up of the internal voltage converter	
	0	1	0	*	*	*	*	*	DC[1:0]		XX			
(30)Test Command	0	1	0	1	1	1	1	*	*	*	*	F1h to FFh	IC test command. Do not use!	
(31)Test Mode Reset	0	1	0	1	1	1	1	0	0	0	0	F0h	Command of test mode reset	

Note: Do not use any other command,or system malfunction may result.

7.2 Interface Timing characteristics

Note: Please refer to IC: NT75451 data sheet for more details.

7.2.1 Reset timing

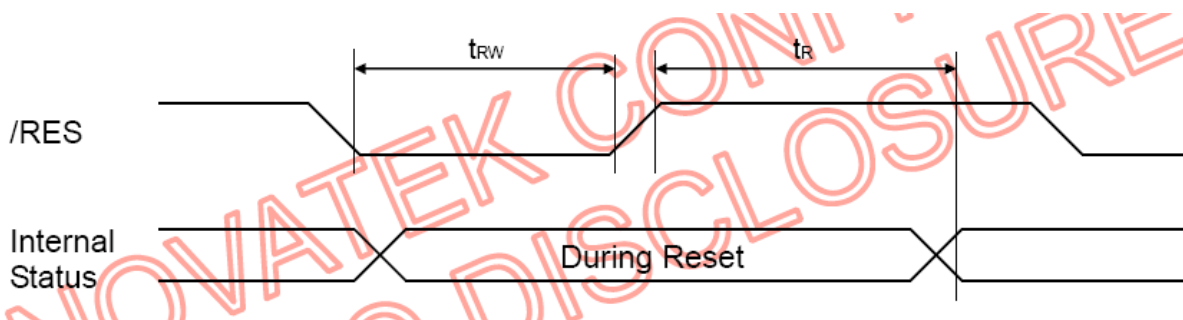

Fig.1 Reset timing

Symbol	Parameter	Min.	Typ.	Max.	Unit	Condition
t_R	Reset Time	-	-	1.0	μs	
t_{RW}	Reset low pulse width	10	-	-	μs	/RES

Table.2 Reset timing characteristics at VDD=2.7~3.6V,Ta=-40~+85°C

7.2.2 Parallel Timing characteristics

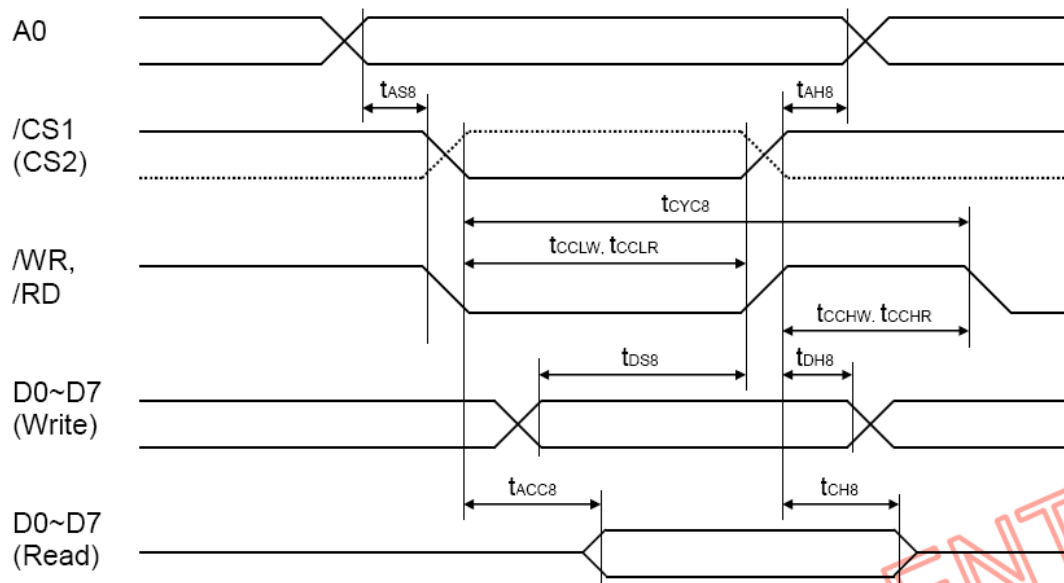

Fig.2 Read/write characteristics for 8080 series MPU

Symbol	Parameter	Min.	Typ.	Max.	Unit	Condition
T_{AH8}	Address hold time	0	-	-	ns	A0
T_{AS8}	Address setup time	0	-	-	ns	
t_{CYC8}	System cycle time	240	-	-	ns	
t_{CCLW}	Control low pulse width (write)	80	-	-	ns	/WR
t_{CCLR}	Control low pulse width (read)	80	-	-	ns	/RD
t_{CCHW}	Control high pulse width (write)	80	-	-	ns	/WR
t_{CCHR}	Control high pulse width (read)	60	-	-	ns	/RD
T_{DS8}	Data setup time	30	-	-	ns	D0~D7
T_{DH8}	Data hold time	0	-	-	ns	
t_{ACC8}	/RD access time	-	-	70	ns	D0~D7, $C_L = 100\text{pF}$
T_{CH8}	Output disable time	5	-	50	ns	

Table.3 Read/write characteristics for 8080 series at $V_{DD}=2.7\sim 3.6\text{V}$, $T_a=-40\sim +85^\circ\text{C}$

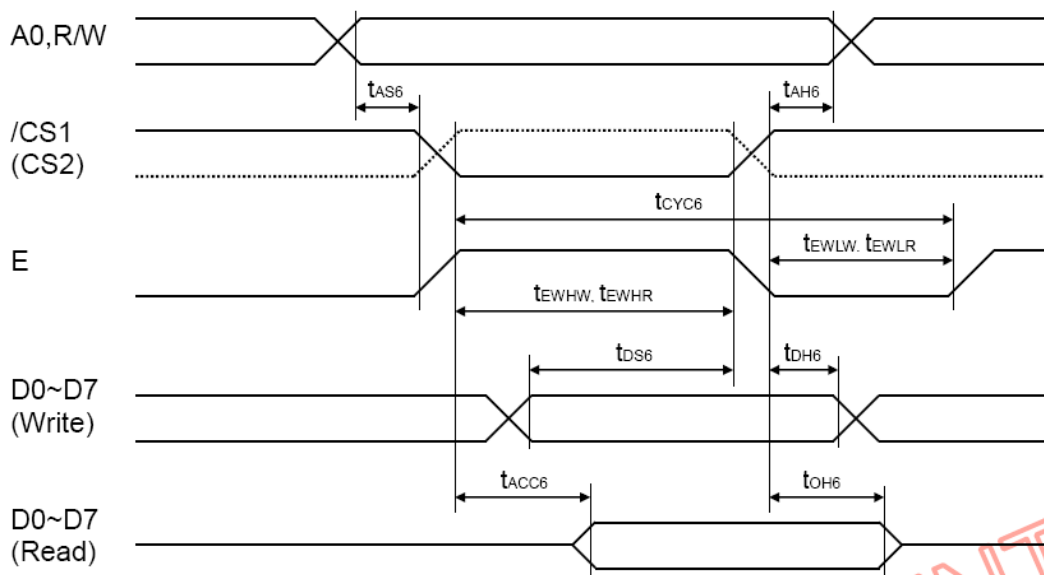

Fig.3 Read/write characteristics for 6800 series MPU

Symbol	Parameter	Min.	Typ.	Max.	Unit	Condition
t _{AH6}	Address hold time	0	-	-	ns	A0, R/W
t _{AS6}	Address setup time	0	-	-	ns	
t _{CYC6}	System cycle time	240	-	-	ns	
t _{EWHW}	Control high pulse width (write)	80	-	-	ns	E
t _{EWHR}	Control high pulse width (read)	80	-	-	ns	E
t _{EWLW}	Control low pulse width (write)	80	-	-	ns	E
t _{EWLR}	Control low pulse width (read)	60	-	-	ns	E
t _{DS6}	Data setup time	30	-	-	ns	D0~D7
t _{DH6}	Data hold time	0	-	-	ns	
t _{ACC6}	/RD access time	-	-	70	ns	D0~D7 CL = 100pF
t _{OH6}	Output disable time	5	-	50	ns	

Table 4 Read/write characteristics for 8080 series at VDD=2.7~3.6V, Ta=-40~+85°C

7.3 Initialization

1. When the built-in power is being used immediately after turning on the power:

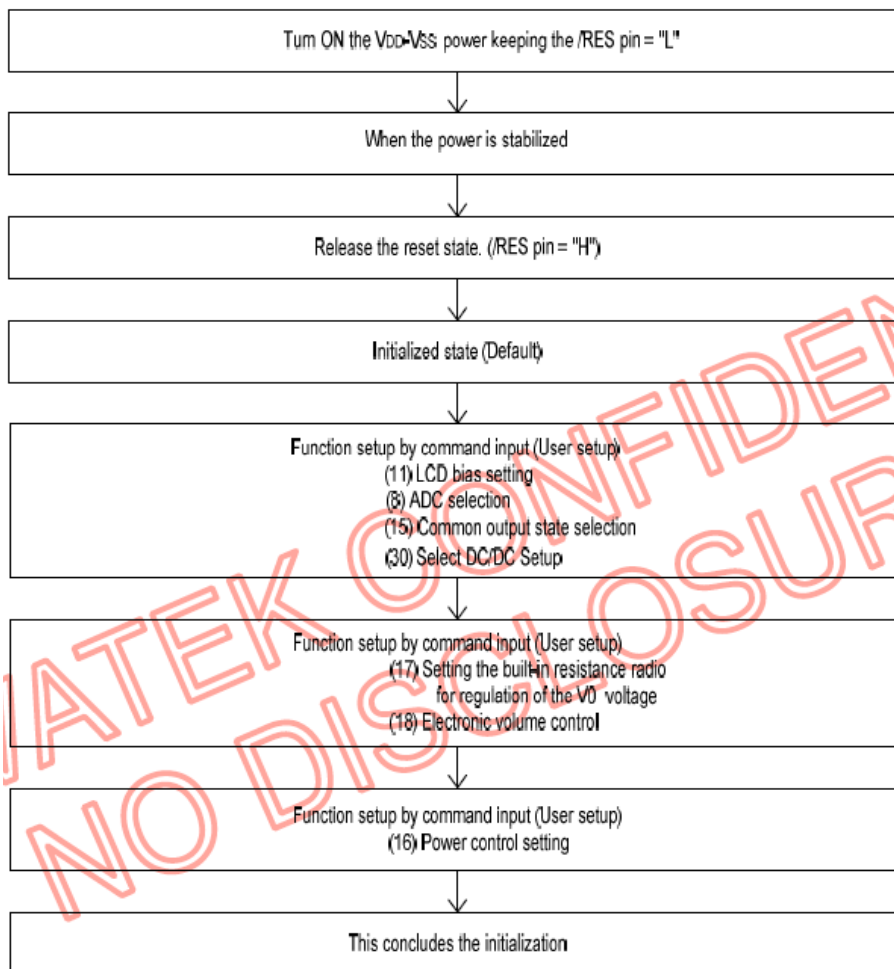

2. When the built-in power is not being used immediately after turning on the power:

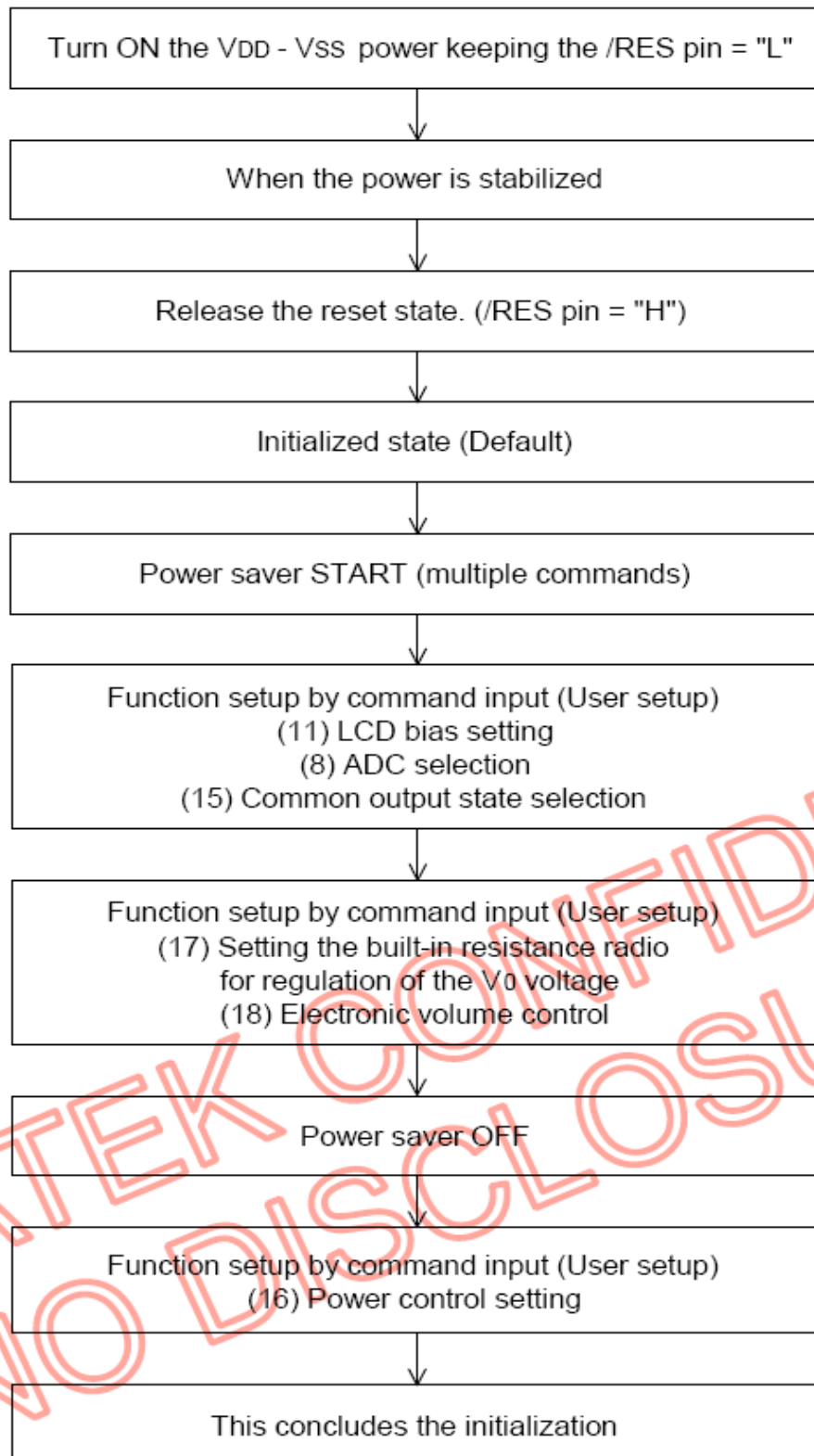

8 Electrical characteristics

 $V_{SS}=0V$, $T_a=25^{\circ}C$

Parameter	Symbol	Condition	MIN	TYP	MAX	UNIT
Logic circuit supply voltage	V_{DD}	--	2.7	3.0	3.6	V
Input voltage for logic circuit	"H"level	$V_{DD}=3.0V$	0.8VDD	--	VDD	
	"L"level		VSS	--	0.2VDD	
Output voltage for logic circuit	"H"level		0.8VDD	--	VDD	
	"L"level		VSS	--	0.2VDD	
Used driver IC	NT75451					

9 LED backlight characteristics

LED CIRCUIT

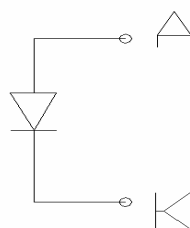

Item	Symbol	Condition	MIN.	TYP.	MAX.	Unit
Forward voltage	V_f	$I_f=15mA$	2.9	3.2	3.3	V
Luminous intensity*	Bp	$I_f=15mA$	55	80	110	cd/m ²
Luminous Uniformity*	ΔBp		70	--	--	%
Peak Wave Length*	λ		--	--	--	nm

Note:

- Measured at the bare LED backlight unit.
- If the backlight is above these maximum ratings for long time, the service life of the LED backlight will reduce or it will cause poor reliability.

10 Optical Characteristics

10.1 Optical Characteristics

Ta=25°C

Parameter	Symbol	Ratings			Unit	Measuring Temp.	Reference	
		Min	Type	Max.				
		9.8	10.0	10.2				
Frame frequency	f		75	-	Hz	25°C	(Note10-2)	
Contrast ratio	Cr($\theta=20^\circ$, $\Phi=90^\circ$ or 270°)	3.0	-	-		25°C	(Note10-3)	
Response time	Turn on	t_{on}	-	-	300	ms	25°C	(Note10-4)
			-	-	-		0°C	
	Turn off	t_{off}	-	-	300	ms	25°C	
			-	-	-		0°C	
Viewing angle (Cr \geq 2)	Up-down	θ_1 ($\Phi=90^\circ$ or	-20	-	30	deg	25°C	(Note10-5)
	Left-right	θ_2 ($\Phi=0^\circ$ or 180°)	-30	-	30	deg	25°C	

(Note10-1) The maximum and minimum ratings don't mean the LCD works well in the whole range of Vo. Vo must be adjusted to optimize the viewing angle and contrast. Refer to definition of drive voltage, refer to 10.2.

(Note10-2) The frequency shouldn't be too low to avoid flicker. Refer to definition of drive voltage, refer to 10.2.

(Note10-3) Refer to 10.2/10.3/10.4/10.5.

(Note10-4) The selected state is dark and non-selected state is white(or bright) with positive type, reversely the selected state is white (or bright) and non-selected state is dark with negative type. Refer to 10.6 definition of response time.

(Note10-5) Generally the viewing direction is 6:00 or 12:00, sometimes 3:00 or 9:00. The range of left to right and up to down based on Cr=2 show the viewing angle. Viewing angle range isn't the range of defects inspection. Refer to 10.4.

10.2 Definition of drive voltage

(1) Definition of drive voltage and waveform

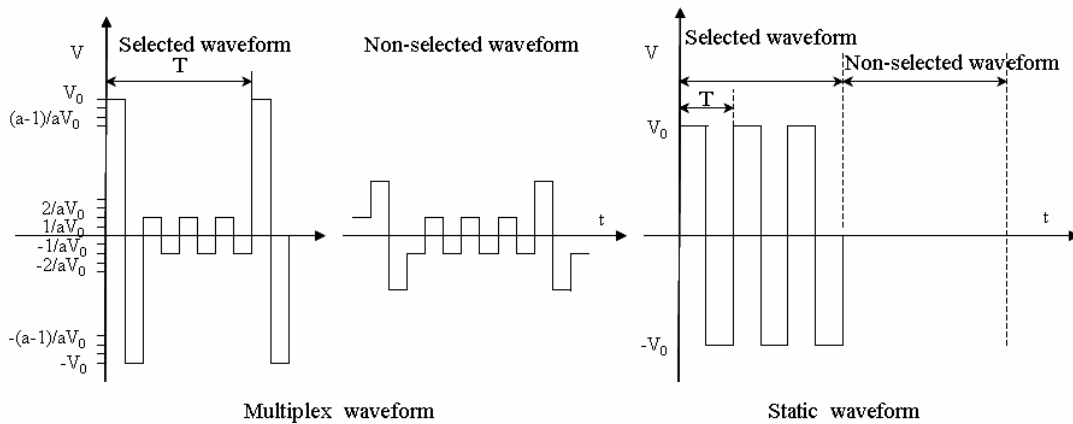

Fig.1 Definition of drive voltage and waveform

Operating voltage: V_0

Frame frequency: $f=1/T$

Duty: $1/N$

Bias: $1/a$

(2) Operating voltage: V_0

TIANMA can evaluate whether the LCD can be redesigned to obtain customer preferable performance if customer's LCD drive voltage isn't adjustable.

10.3 Optical characteristics measurement equipment and method

The setup and test method are showed in fig.2. Test methods are different according to different illumination mode.

Transmissive mode: light resource is placed at the back of LCD.

Reflective mode and transflective mode: light resource is placed at the front side of LCD.

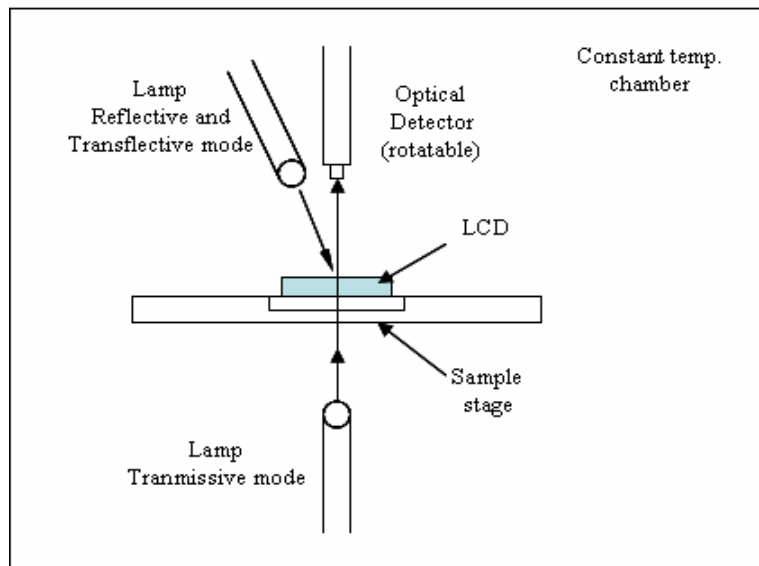

Fig.2 Optical characteristics measurement equipment

The chamber temperature, light resource and driving signal should be stable before testing. If test the characteristics under high or low temperature, the test system should be stable for more than 10 minutes before testing.

10.4 Definition of viewing direction

Refer to the graph below marked by θ and ϕ

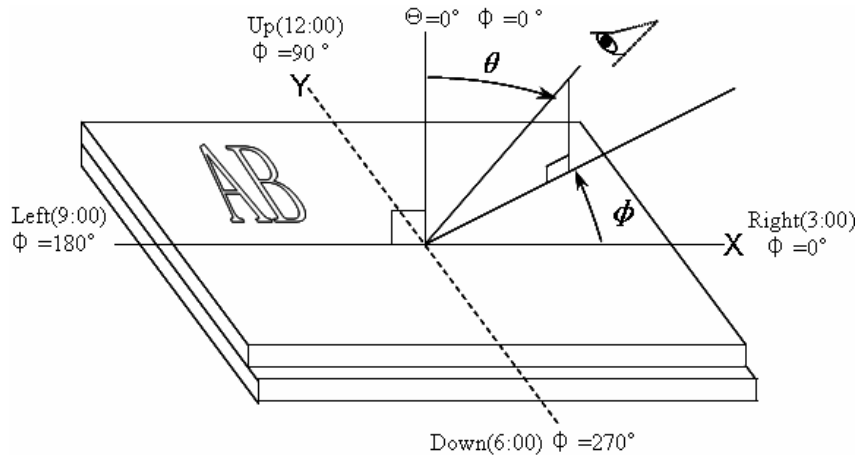

Fig.3 Definition of viewing direction

10.5 Definition of contrast ratio

Contrast ratio can be calculated by the formula (10-1) below for positive type. If the LCD is negative type, $Cr(\theta, \phi)$ is equal to luminance (θ, ϕ , non-selected state) divided by luminance (θ, ϕ , selected state). Note3-4 shows the relationship between selected state, non-selected state and bright state, dark state.

$$Cr(\theta, \phi) = \frac{L_2}{L_1} = \frac{\text{Luminance}(\theta, \phi) \text{ (Bright state)}}{\text{Luminance}(\theta, \phi) \text{ (Dark state)}} \quad (10-1)$$

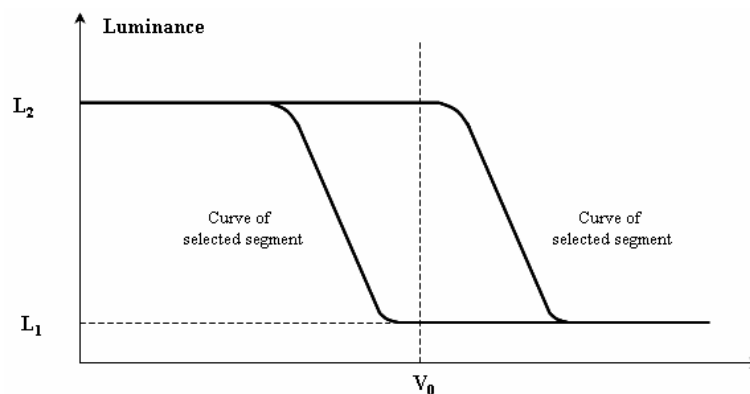

Fig.4 Electro-optical characteristic (EOC) graph (positive type)

10.6 Definition of response time

Turn on time (rise time): $t_{on} = t_d + t_r$ (from non-selected state to selected state)

Turn off time (fall time): $t_{off} = t_D + t_R$ (from selected state to non-selected state)

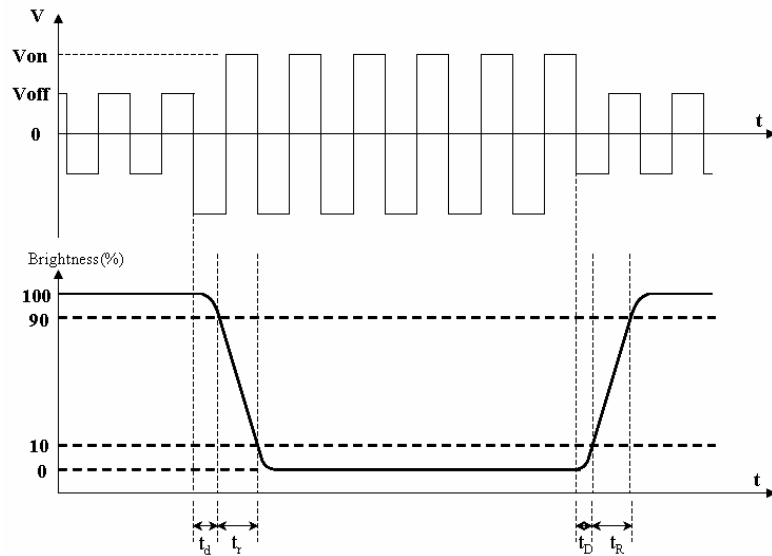

Fig.5 Definition of response time (positive type)

10.7 Definition of viewing angle

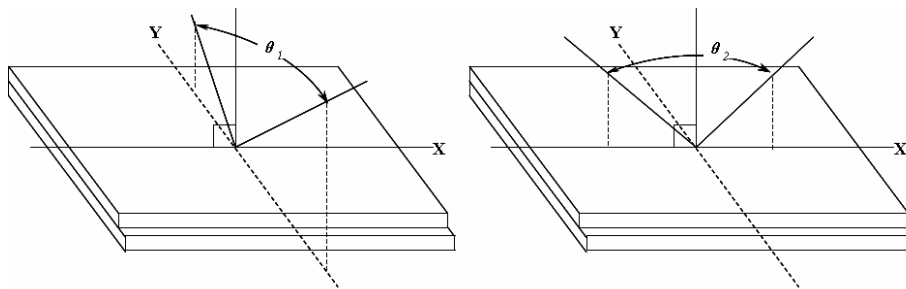

Fig 6 Definition of viewing angle

θ_1 ——range of viewing angle from up to down

θ_2 ——range of viewing angle from left to right.

11 Reliability

11.1 Content of Reliability Test

Ta=25°C

No	Test Item	Test condition	Criterion
1	High Temperature Storage	80°C±2°C 120H Restore 2H at 25°C Power off	After testing, cosmetic and electrical defects should not happen.
2	Low Temperature Storage	-40°C±2°C 120H Restore 2H at 25°C Power off	
3	High Temperature Operation	70°C±2°C 120H Restore 2H at 25°C Power on	
4	Low Temperature Operation	-20°C±2°C 120H Restore 4H at 25°C Power on	
5	High Temperature & Humidity Operation	40°C±2°C 90%RH 120H Power on	
6	Temperature Cycle	-30°C→25°C→80°C 30min 5min 30min after 10cycle, Restore 2H at 25°C Power off	
7	Vibration Test	10Hz~150Hz, 50m/s ² , 40min	
8	Shock Test	Half-sine wave, 100m/s ² , 11ms	

Notes:

- Each test item applies for a test sample only once, The test sample can not be used again in any other test item.
- The test sample is inspected after 2 hours or more storing at room temperature and room humidity after each test item is finished.
- The criteria refer to 11.2.

11.2 Inspection of criteria

Remark NO.	Content
1	Functional test is OK. Missing Segment, shorts, unclear segment, nondisplay, display abnormally, liquid crystal leak are unallowable.
2	After testing, cosmetic defects should not happen, no low temperature bubbles, seal loose and fall, frame rainbow, ACF bubble growing are unallowable in the appearance test.
3	Total current consumption should not be over 10% of initial value.
4	After tests being executed, Contrast must be larger than 70% of its initial value prior to the tests.
5	No glass crack, chipped glass, end seal loose frame crack and so on.
6	No structure loose and fall.

12 Package

TIANMA MICROELECTRONICS CO.

Packing Standards:

Quantity of products to be packaged in a case: 360 pcs

Outlook size(Carton size): 550X385X320 mm

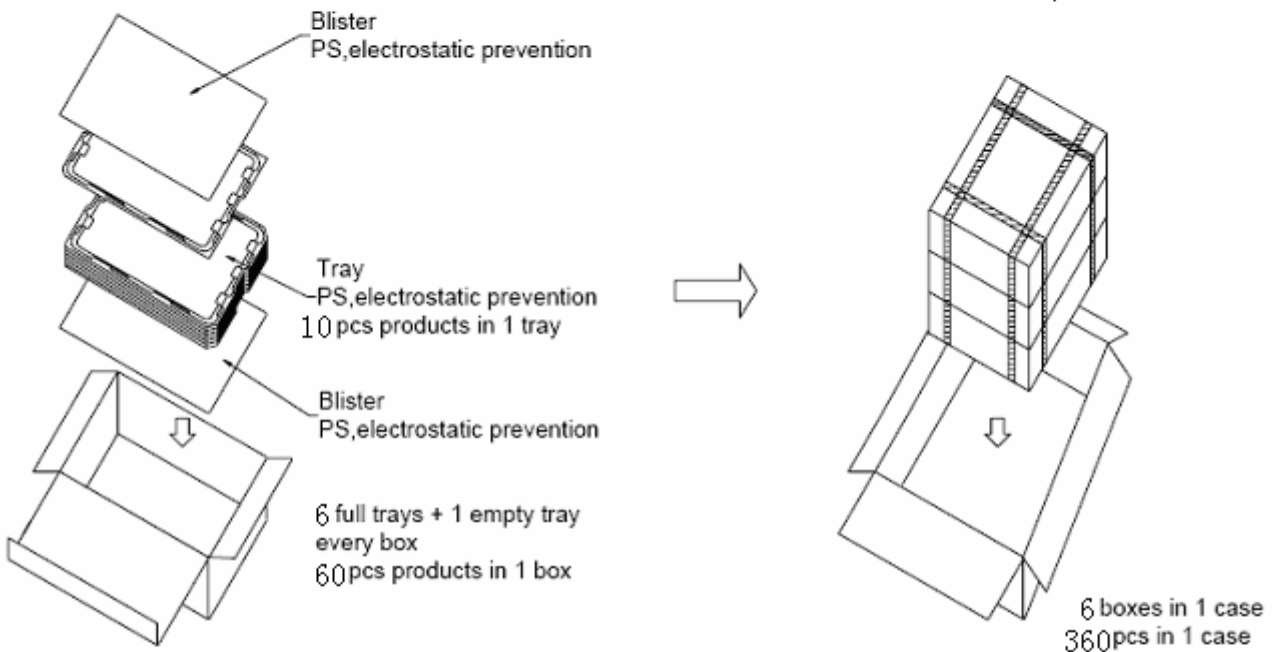

Package Sign:

Case Mark

Remark

BMS

P.O.No.

Part No.

QTY

CTN.No.

TTL CTN.No.

MADE IN CHINA

Care Mark

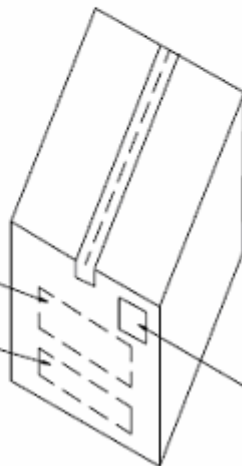

Care Mark:



LEAD FREE Label(40X40mm)

13 Quality level

13.1 Classification of defects

Major defects (MA): A major defect refers to a defect that may substantially degrade usability for product applications, including all functional defects (such as no display, abnormal display, open or missing segment, short circuit, missing component), outline dimension beyond the drawing, progressive defects and those affecting reliability.

Minor defects (MI): A minor defect refers to a defect which is not considered to be able to substantially degrade the product application or a defect that deviates from existing standards almost unrelated to the effective use of the product or its operation, such as black spot, white spot, bright spot, pinhole, black line, white line, contrast variation, glass defect, polarizer defect, etc.

13.2 Definition of inspection range

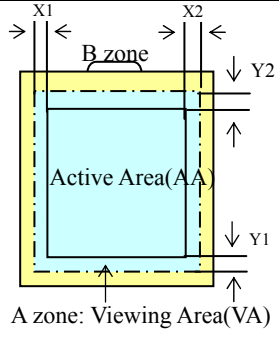
<p>For LCD defects, dividing two areas to make a judgment (according figure 1).</p> <p>A zone : Inside Viewing area B zone : Outside Viewing area</p> <p>X1(A.A~V.A): 2mm X2(A.A~V.A): 2mm Y1(A.A~V.A): 2mm Y2(A.A~V.A): 2mm</p>	 <p>Figure 1</p>
--	---

13.3 Inspection items and general notes

General notes	<p>① Should any defects which are not specified in this standard happen, additional standard shall be determined by mutual agreement between customer and TIANMA.</p> <p>② Viewing area should be the area which TIANMA guarantees.</p> <p>③ Limit sample should be prior to this Inspection standard.</p> <p>④ Viewing judgment should be under static pattern.</p> <p>⑤ Inspection conditions</p> <p style="margin-left: 40px;">Inspection distance: 250 mm (from the sample) Temperature : 25±5 °C</p> <p style="margin-left: 40px;">Inspection angle : 45 degrees in 12 o'clock direction (all defects in viewing area should be inspected from this direction)</p>	
Inspection items		
	Pinhole, Bright spot, Black spot, White spot, Black line, White Line, Foreign particle, Bubble	The color of a small area is different from the remainder. The phenomenon doesn't change with voltage
	Contrast variation	The color of a small area is different from the remainder. The phenomenon changes with voltage
	Polarizer defect	Scratch, Dirt, Particle, Bubble on polarizer or between polarizer and glass
	Functional defect	no display, display abnormally, open or missing segment, short circuit, False viewing direction
	Glass defect	Glass crack, Shaved corner of glass, Surplus glass
	Segment defect	Pin holes or cracks in segment, Transformation of segment
	PCB defect	Components assembly defect

13.4 Outgoing Inspection level

Outgoing Inspection standard	Inspection conditions	Inspection				
		Min.	Max.	Unit	IL	AQL
Major Defects	See 13.3 general notes	See	13.5		II	0.65
Minor Defects	See 13.3 general notes	See	13.5		II	1.5

Note: Sampling standard conforms to GB2828

13.5 Inspection Items and Criteria

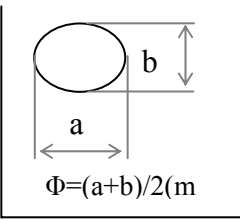
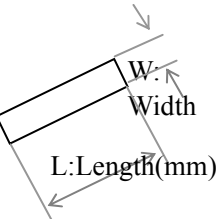
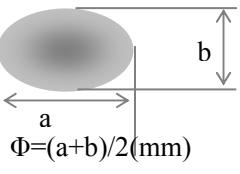
Inspection items			Judgment standard			
			Category		Acceptable number	
					A zone	B zone
1	Black spot, White spot, Bright Spot, Pinhole, Foreign Particle, Particle in or on glass, Scratch on glass		A	$\Phi \leq 0.10$	Neglected	Neglected
			B	$0.10 < \Phi \leq 0.20$	3	
			C	$0.20 < \Phi$	0	
2	Black line, White line, Particle Between Polarizer and glass, Scratch on glass		A	$W \leq 0.02$	Neglected	Neglected
			B	$0.02 < W \leq 0.05$ $L \leq 3.0$	3	
			C	$W > 0.05$ or $L > 3.0$	0	
3	Contrast variation		A	$\Phi \leq 0.2$	Neglected	Neglected
			B	$0.2 < \Phi \leq 0.3$	2	
			C	$0.3 < \Phi \leq 0.4$	1	
			D	$0.4 < \Phi$	0	
			Total defective point(B,C)		3	
4	Bubble inside cell		any size	none	none	
5	Polarizer defect (if Polarizer is used)	Scratch ,damage on polarizer, Particle on polarizer or between polarizer and glass.	Refer to item 1 and item 2.			
			Bubble, dent and convex	A	$\Phi \leq 0.3$	Neglected
	B	$0.3 < \Phi \leq 0.7$		2		

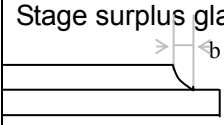
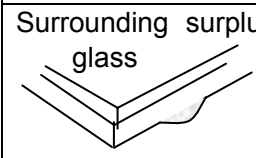
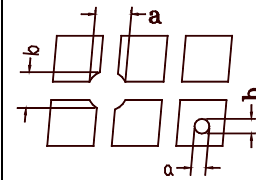
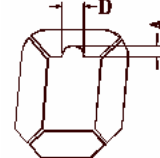
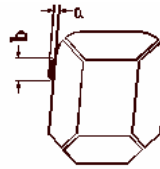
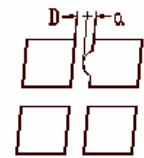
			C	$0.7 < \Phi$	0		
6	Surplus glass	Stage surplus glass 	$b \leq 0.3\text{mm}$				
		Surrounding surplus glass 	Should not influence outline dimension and assembling.				
7	Open segment or open common	Not permitted					
8	Short circuit	Not permitted					
9	False viewing direction	Not permitted					
10	Contrast ratio uneven	According to the limit specimen					
11	Crosstalk	According to the limit specimen					
12	Black /White spot(display)	Refer to item 1					
13	Black /White line(display)	Refer to item 2					
14	Pin holes and cracks in segment		not counted	Max.3 dots allowed		Max.3 dots allowed	
			$x < 0.1\text{mm}$	$0.1\text{mm} \leq x \leq 0.2\text{mm}$			
			$x = (a+b)/2$				
			not counted	Max.2 dots allowed each segment			
$A < 0.1\text{mm}$	$0.1\text{mm} \leq A \leq 0.2\text{mm}$ $D < 0.25\text{mm}$						
15	Transformation of segment		not counted	Max.1 defect allowed each segment		Max.3 defects allowed	
			$x < 0.1\text{mm}$	$0.1\text{mm} \leq x \leq 0.2\text{mm}$			
			$x = (a+b)/2$				
			not counted	Max.1 defect allowed each segment			
$a < 0.1\text{mm}$	$0.1\text{mm} \leq a \leq 0.2\text{mm}$ $D > 0$						

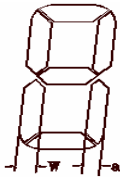
			$0.8W \leq a \leq 1.2W$ a =measured value of width W =nominal value of width	Max.2 defects allowed
--	--	---	--	-----------------------

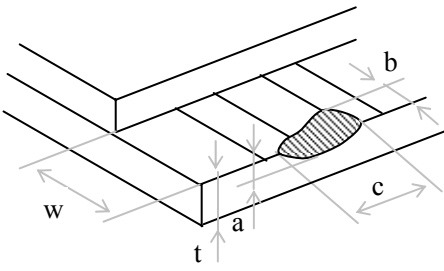
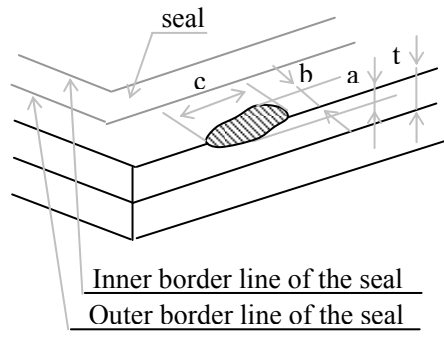
Inspection items		Judgment standard		
		Category(application: B zone)	Acceptable number	
16	Glass defect crack	①The front of lead terminals	A $a \leq t, b \leq 1/5W, c \leq 3\text{mm}$	Max.3 defects allowed
			B Crack at two sides of lead terminals should not cover patterns and alignment mark	
		②Surrounding crack—non-contact side		
			$b < \text{Inner border line of the seal}$	

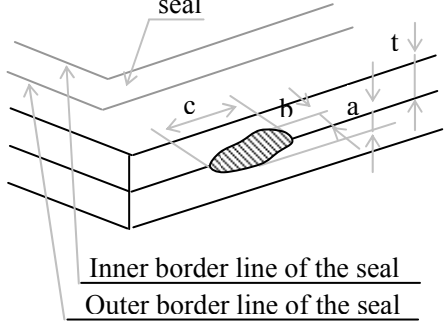
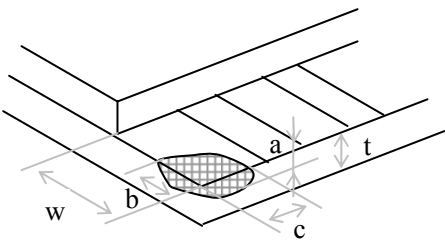
		<p>③ Surrounding crack— contact side seal</p>  <p>Inner border line of the seal Outer border line of the seal</p>	<p>$b < \text{Outer borderline of the seal}$</p>		
		<p>④ Corner</p> 	<p>A</p>	<p>$a \leq t, b \leq 3.0, c \leq 3.0$</p>	
			<p>B</p>	<p>Glass crack should not cover patterns u and alignment mark and patterns.</p>	

Inspection items		Judgment standard	
		Category(application: B zone)	
17	PCB defect	<p>Component soldering: No cold soldering、short、open circuit、burr、tin ball The flat encapsulation component position deviation must be less than 1/3 width of the pin (Pic.1); the sheet component deviation: Pin deviates from the pad and contact with the near components is not permitted (Pic.2)</p>	
		<p>lead defect: The lead lack must be less than 1/3 of its width; The lead burr must be less than 1/3 of the seam; Impurities connect with the near leads is not permitted</p>	
		<p>Connector soldering: Soldering tin is at contact position of the plug and socket is not permitted No foundation is scald Serious cave distortion on plug and socket contact pin is not permitted</p>	
		<p>Glue on root of the speaker receiver and motor lead: The insulative coat of the lead must join into the PCB; the protected glue must envelop to the insulative coat.</p>	

14 Precautions for Use of LCD Modules

14.1 Handling Precautions

- 14.1.1 The display panel is made of glass. Do not subject it to a mechanical shock by dropping it from a high place, etc.
- 14.1.2 Liquid in LCD is hazardous substance, if the display panel is damaged and the liquid crystal substance inside it leaks out, be sure not to get any in your mouth, if the substance comes into contact with your skin or clothes, thoroughly and promptly wash it off using soap and water.
- 14.1.3 Do not apply excessive force to the display surface or the adjoining areas since this may cause the color tone to vary.
- 14.1.4 Don't touch, push or rub the exposed polarizer covering the display surface of the LCD module with anything harder than an HB pencil lead, the polarizer is soft and easily scratched, handle it carefully.
- 14.1.5 Don't put or attach anything on the display area to avoid leaving any marks on.
- 14.1.6 If the display surface is contaminated or becomes dusty, breathe on the surface and gently wipe it with a soft dry cloth. do not scrub hard to avoid damage the surface. If still not completely clear, moisten cloth with one of the following solvents:
- Isopropyl alcohol
 - Ethyl alcohol
- Solvents other than those mentioned above may damage the polarizer. Especially, do not use the following:
- Water
 - Ketone
 - Aromatic solvents
- 14.1.7 Do not attempt to disassemble the LCD Module.
- 14.1.8 If the logic circuit power is off, do not apply the input signals.
- 14.1.9 Avoid using the same display pattern long time (continuous ON segment). Software must be prepared so that the pattern will be changed
- 14.1.10 To prevent destruction of the elements by static electricity, be careful to maintain an optimum work environment.
- a. Be sure to ground the body and electric appliances when handling the LCD Modules. It is preferable to use conductive mat on table and wear cotton clothes or conductive processed fibre. Synthetic fibre is not recommended.
 - b. Tools required for assembly, such as soldering irons, must be properly ground.
 - c. To reduce the amount of static electricity generated, do not conduct assembly and other work under dry conditions.
 - d. The LCD Module is coated with a film to protect the display surface. Be careful and slow when peeling off this protective film since static electricity may be generated. It is recommended to use ionic fan or machine when operating. It is recommended to remove the protection foil slowly (> 3 sec.).
 - e. It is preferable to wear gloves etc, to avoid damaging the LCD. Please do not touch electrodes with bare hands or avoid any other contamination.

14.2 Storage precautions

- 14.2.1 When storing the LCD modules, avoid exposure to direct sunlight or to the light of fluorescent lamps.
- 14.2.2 The LCD modules should be stored under the storage temperature range. If the LCD modules will be stored for a long time, the recommend condition is:
- Temperature : 5°C ~ 40°C
 - Relatively humidity: ≤80%
- 14.2.3 The LCD modules should be stored in a clean environment or room, free from acid, alkali and harmful gas.
- 14.2.4 Store the module in anti-static electricity container and without any physical load.

14.3 Transportation precautions

The LCD modules should be no falling and violent shocking during transportation, and also should avoid excessive press, water, damp and sunshine.

14.4 Soldering

- 14.4.1 Use the high quality solders, only solder the I/O terminals.
- 14.4.2 No higher than 280°C and time less than 3-4 second during soldering.
- 14.4.3 Rewiring: no more than 3 times.
- 14.4.4 when you remove connector or cable soldered to I/O terminals, please confirm that solder is fully melted. If you remove by force, electrodes at I/O terminals may be damaged (or stripped off). It is recommended to use solder suction machine.

15. LCD Module Part Numbering System

TM	128 x 64	H6	C	C	O	W	A
-----------	-----------------	-----------	----------	----------	----------	----------	----------

①	②	③	④	⑤	⑥	⑦	⑧
---	---	---	---	---	---	---	---

NO.	Explanation
①	TIANMA module indicating
②	Module type: 128 X 64 dots
③	TIANMA module series
④	LCD type
	C FSTN,positive
⑤	Backlight type
	C Transflective , LED
⑥	Technology
	O Other combination
⑦	The color of backlight
	W White
⑧	Module Function
	A Base function