

OA200EC Series

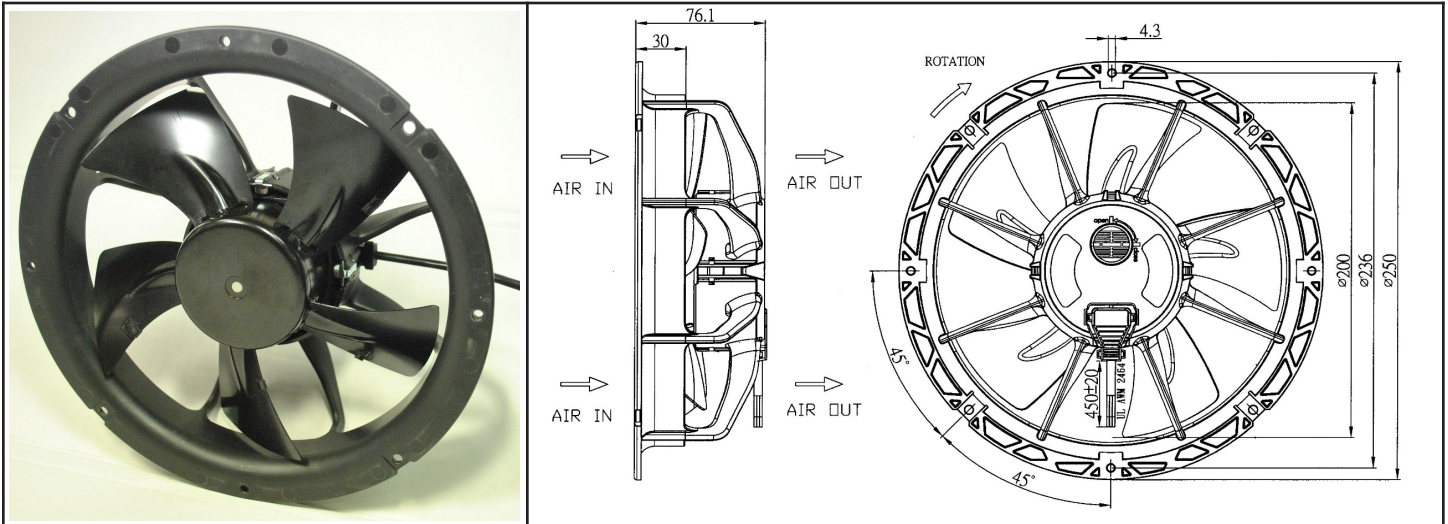

EC Fan Dual Speed- 115V, 230V
250x76mm (9.85"x 3.0")



Frame	PBT UL94V-0 Plastic	<u>Operating Temperature</u> Ball Bearing -25C ~ +50C <u>Life Expectancy</u> Ball Bearing 40,000 hours (L10 at 40C) IP55 Rated Weight: ~1000 grams <u>Storage Temperature</u> -40C ~ +80C m2	<p>Airflow (CFM)</p>
Impeller	Metal		
Connection	3x Lead wires Black (line), Blue(neutral), Brown(speed)		<p>MOTOR WIRING DIAGRAMS</p>
Motor	Brushless EC motor, thermally protected		
Bearing System	Dual ball		
Insulation Resistance	>100M ohm between lead-wire and frame (500VDC)		
Dielectric Strength	1 min at 1500 VAC, 50/60Hz		

Part Number	OA200EC-11-1WB	OA200EC-22-1WB (UL Pending)
Nominal Voltage	115 VAC	230 VAC
Rated Power	8/26W (L/H Speed)	8/26W (L/H Speed)
Nominal Current	0.12/0.37 A (L/H Speed)	0.07/ 0.23 A (L/H Speed)
Frequency (Hz)	50 / 60	50 / 60
Rated Speed (RPM)	1400/2200 (L/H Speed)	1400/2200 (L/H Speed)
Airflow (CFM)	300/480 (L/H Speed)	300/480 (L/H Speed)
Noise Level (dB)	44/55 (L/H Speed)	44/55 (L/H Speed)
Max. Static Pressure	0.27" / 0.50" H ₂ O	0.27" / 0.50" H ₂ O