

## High Performance, Constant Current Switching Regulator For White LED

### General Description

The LP3302 is a 1.1MHz PWM boost switching regulator designed for constant current white LED driver applications. The LP3302 can drive a string of up to 8 white LEDs from a 3.2V supply or 21 white LEDs from a 5V supply in series, ensuring uniform brightness and eliminating several ballast resistors. The LP3302 implements a constant frequency 1.1MHz PWM control scheme. The high frequency PWM operation also saves board space by reducing external component size. To improve efficiency, the feedback voltage is set to 250mV, which reduces the power dissipation in the current setting resistor.

Highly integration and internal compensation network minimizes as 5 external component counts. Optimized operation frequency can meet the requirement of small LC filters value and low operation current with high efficiency.

### Ordering Information

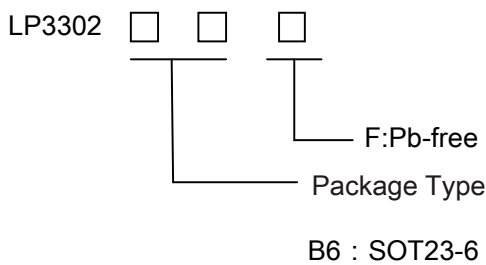

### Features

- ✧ High Efficiency: 88%
- ✧ 1.1MHz Fixed-Frequency PWM Operation
- ✧ Maximum Output Voltage up to 29V
- ✧ Operating Range : 2.7V to 6V
- ✧ Shutdown Supply Current:<1uA
- ✧ Available in SOT23-6 Package
- ✧ Built-in Over Voltage Protection
- ✧ Minimize the External Component
- ✧ RoHS Compliant and 100% Lead Pb-Free

### Pin Configurations

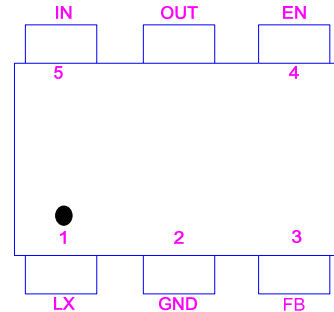

### Applications

- ✧ WLED Backlight driver
- ✧ OLED Backlight driver
- ✧ PDA
- ✧ DSC
- ✧ Camera Flash WLED driver

### Typical Application Circuit

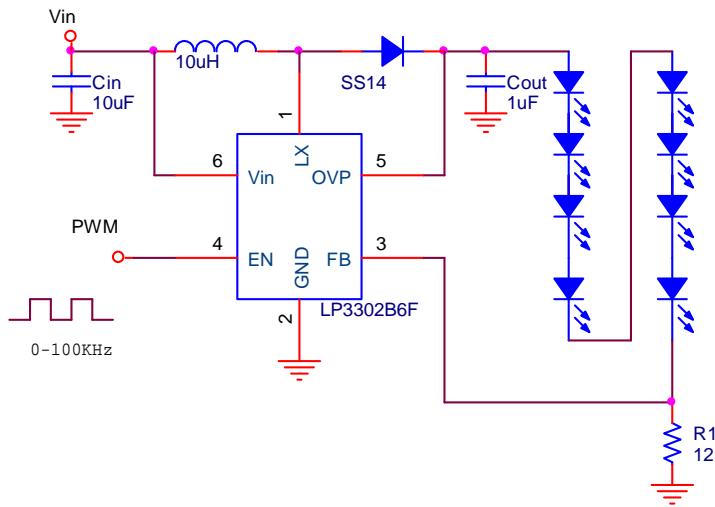

### Marking information

Device	Marking	Package	Shipping
LP3302B6F	LPS F3XXX	SOT23-6	3K/REEL

## Application Circuit

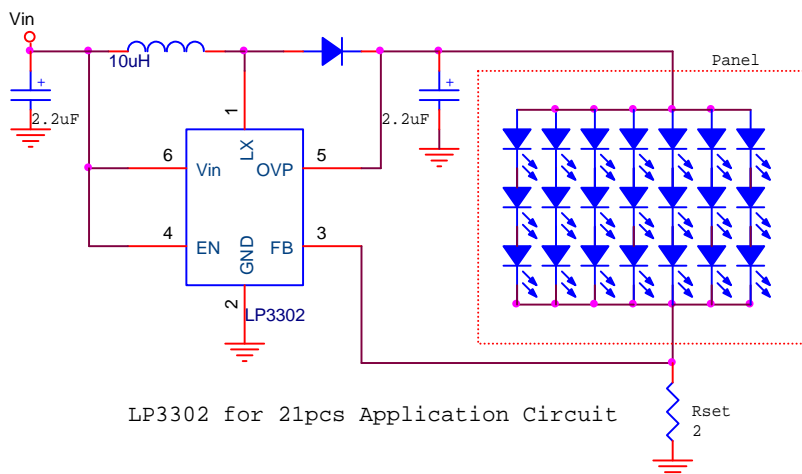
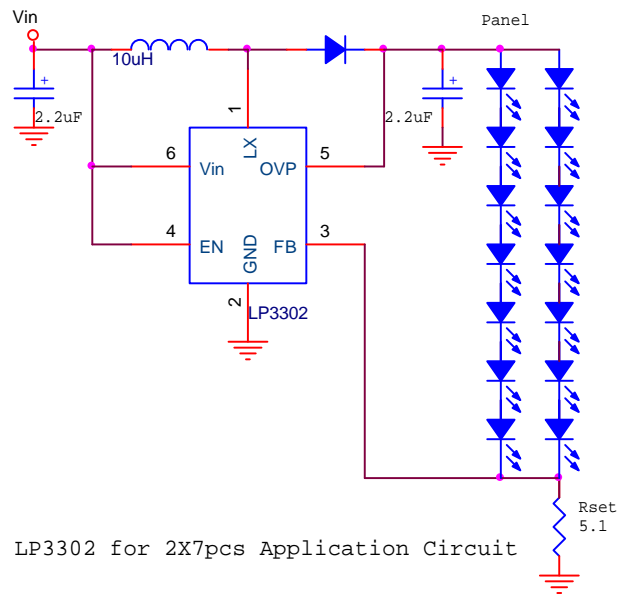
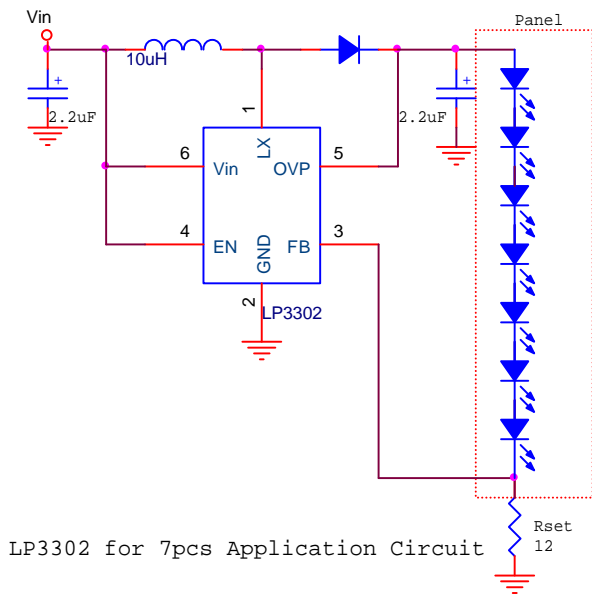
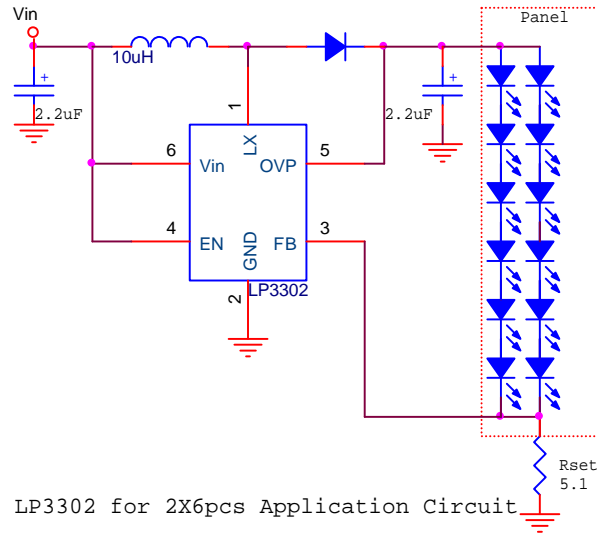
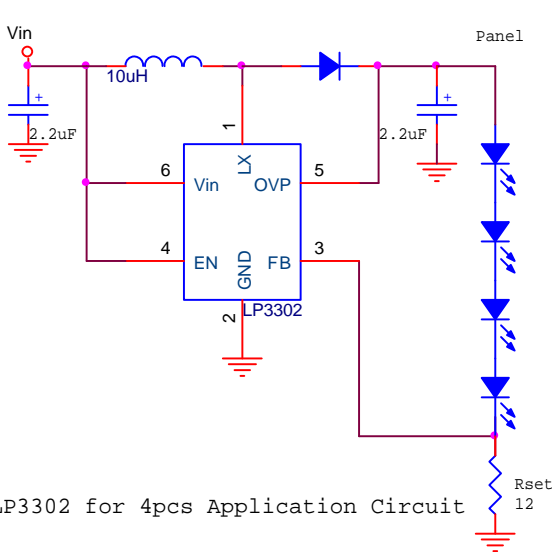

## Functional pin description

SOT-23-6	Pin Name	Pin Function
1	LX	Switch Pin. Connect this Pin to inductor and catch diode. Minimize the track area to reduce EMI.
2	GND	Ground Pin
3	FB	Feedback Reference Voltage Pin. Series connect a resistor between WLED and ground as a current sense. Sense the current feedback voltage to set the current rating.
4	EN	Chip Enable (Active High). Voltage sensing input to trigger the function of over voltage protection. Note that this pin is high impedance. There should be a pull low 100kΩ resistor connected to GND when the control signal is floating.
5	OUT	OVP Pin. Overvoltage Sense. When VOUT is greater than 29V, the internal N-channel MOSFET turns off until VOUT drops below 29V, then the IC reenters start. Connect a 1uF capacitor from OUT to GND.
6	VIN	Supply Input Voltage Pin. Bypass 1uF capacitor to GND to reduce the input noise.



## Electrical Characteristics

Parameter	Symbol	Test Condition	Min	Typ.	Max	Units
<b>System Supply Input</b>						
Operation voltage Range	VDD		2.7		6	V
Under Voltage Lock Out	VDD			2.4		V
Supply Current	IDD	FB=0V, Switching		0.8	1.3	mA
Shut Down Current	IDD	VEN < 0.4V		0.1	1	uA
Line Regulation		VIN : 3.0~4.3V		3		%
<b>Oscillator</b>						
Operation Frequency	FOSC		0.8	1.1		MHz
Maximum Duty Cycle				92		%
Dimming Frequency			100		500k	Hz
Feedback Voltage	LP3302		235	250	265	mV
<b>MOSFET</b>						
On Resistance of MOSFET	RDS(ON)			0.3		Ω
<b>Protection</b>						
OVP Threshold	VOVP	Rising		29		V
OVP Sink Current				5		μA
OCP				1200		mA
Shut Down Voltage	VEN				0.4	V
Enable Voltage	VEN		1.5			V

## Typical Operating Characteristics

Efficiency vs.  $V_{in}$  (Driving 1WLED)

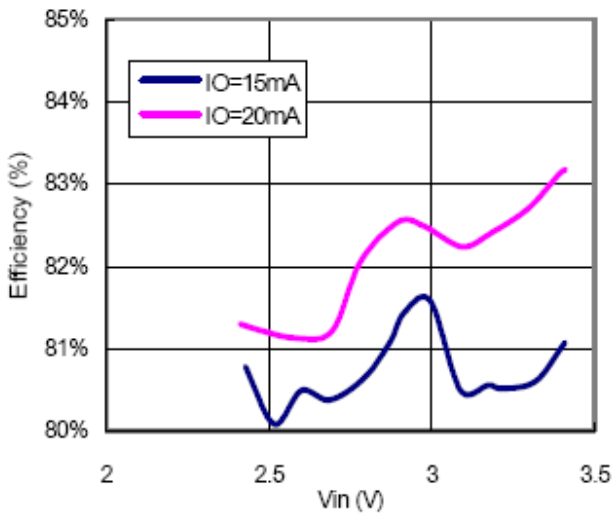

Efficiency vs.  $V_{in}$  (Driving 3WLEDs)

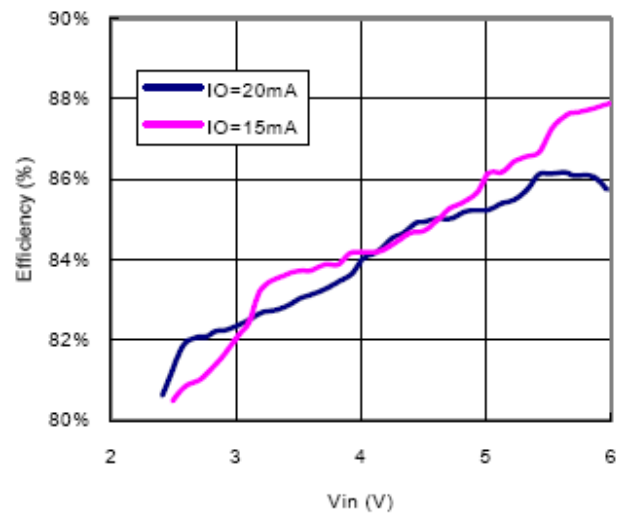

Efficiency vs.  $V_{in}$  (Driving 6WLEDs)

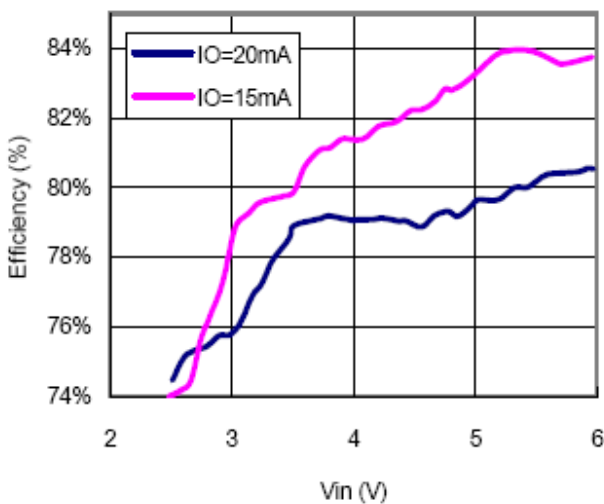

$V_{in}=2.6V$  Driving 2LEDs Stability

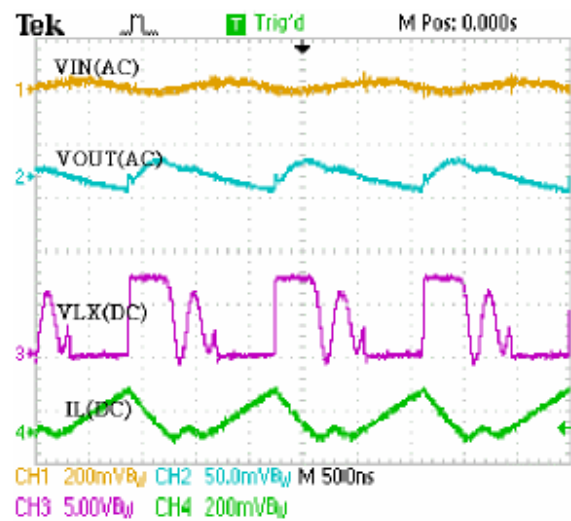

$V_{in}=3.6V$  Driving 2LEDs Stability

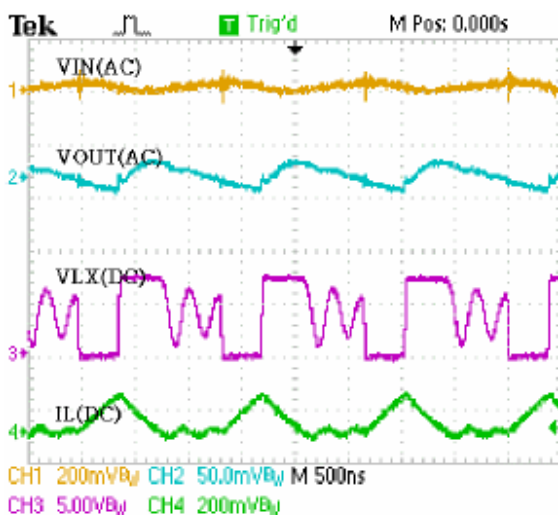

$V_{in}=5V$  Driving 2LEDs Stability

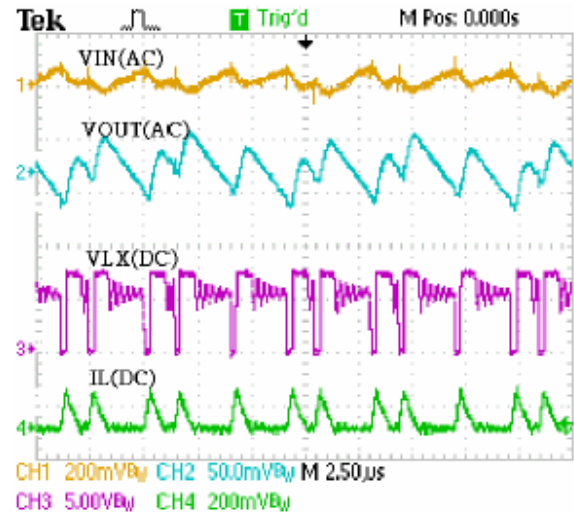

$V_{IN}=2.6V$  Driving 4LEDs Stability

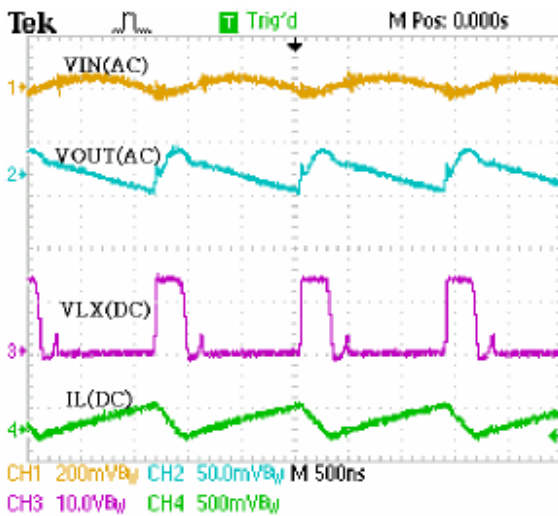

$V_{IN}=3.6V$  Driving 4LEDs Stability

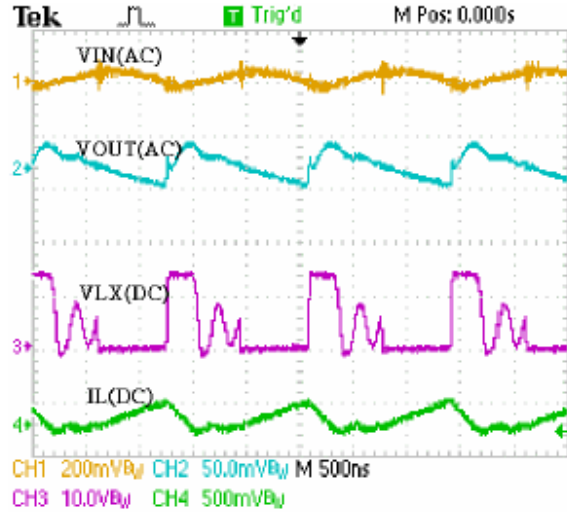

$V_{IN}=5V$  Driving 4LEDs Stability

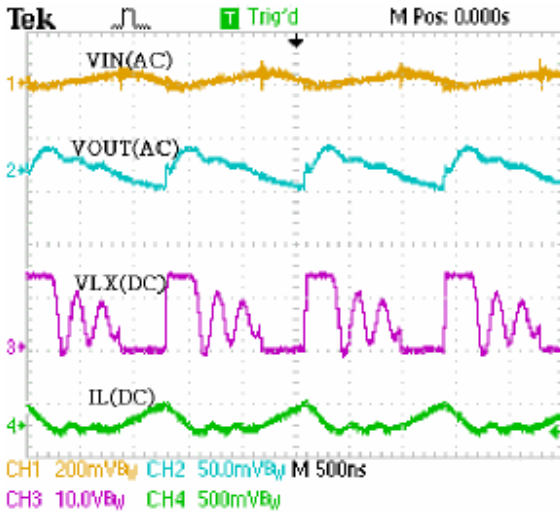

$V_{IN}=2.6V$  Driving 6LEDs Stability

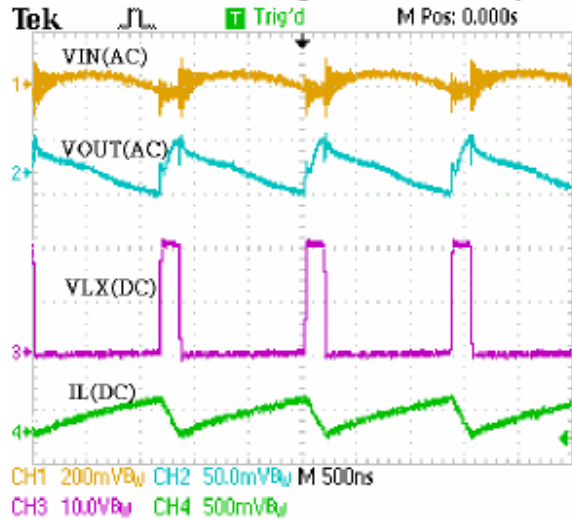

$V_{IN}=3.6V$  Driving 6LEDs Stability

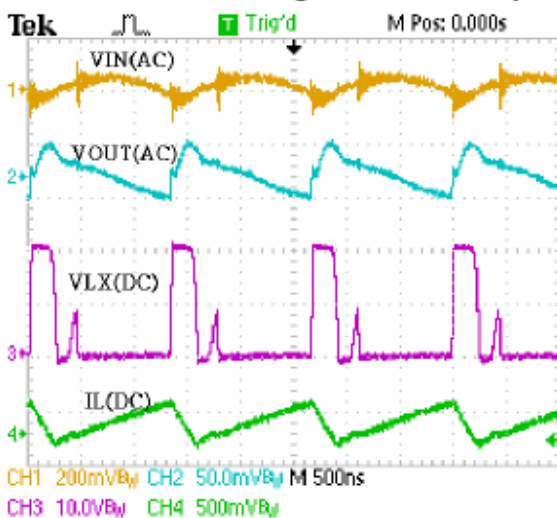

$V_{IN}=5V$  Driving 6LEDs Stability

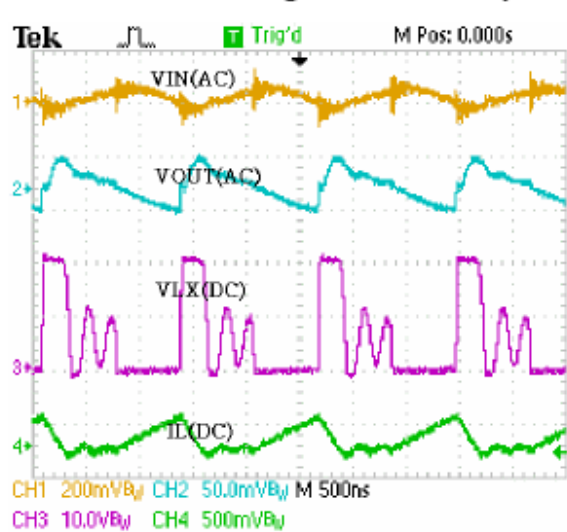



$V_{IN}=3.6V$  Driving 2LEDs Inrush Current

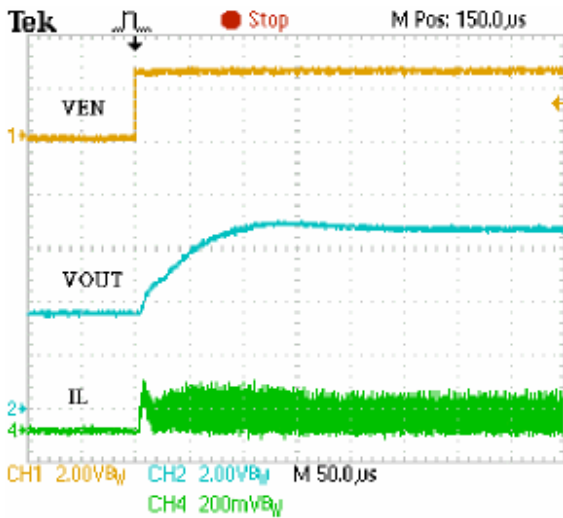

$V_{IN}=3.6V$  Driving 4LEDs Inrush Current

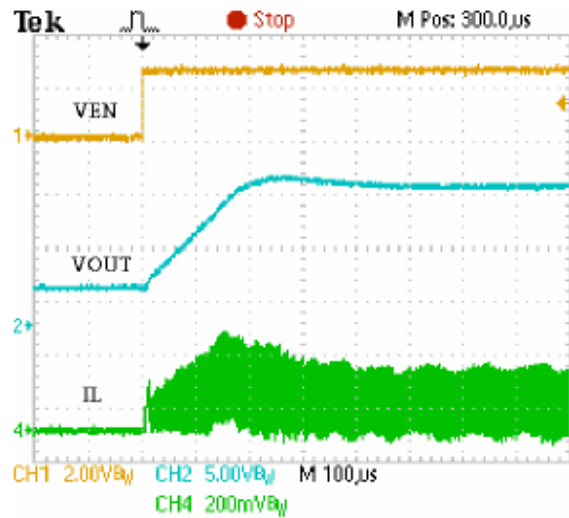

$V_{IN}=3.6V$  Driving 6LEDs Inrush Current

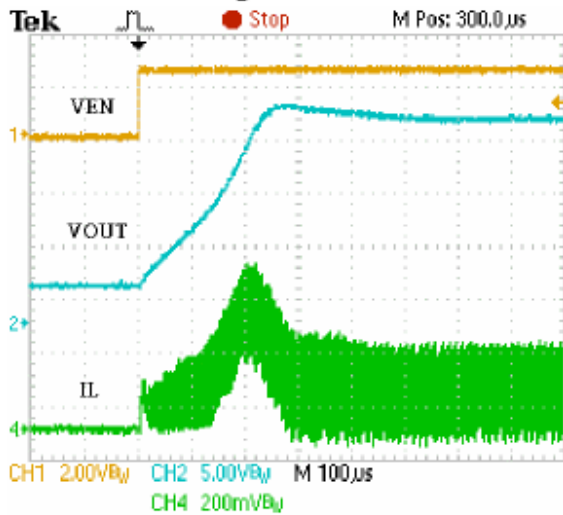

$V_{IN}=3.6V$  Driving 6LEDs 100Hz PWM Dimming

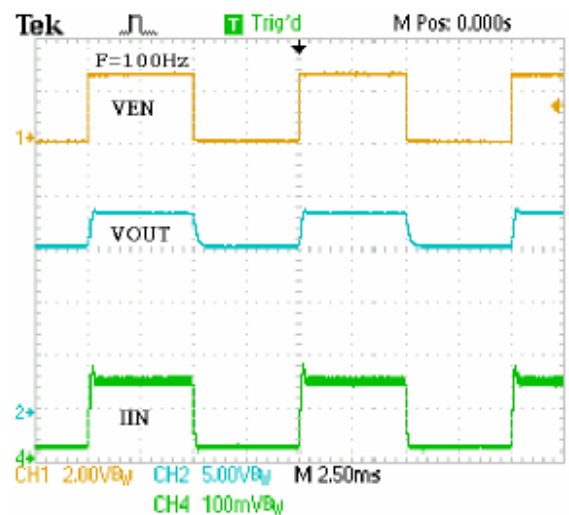

$V_{IN}=3.6V$  Driving 6LEDs 1KHz PWM Dimming

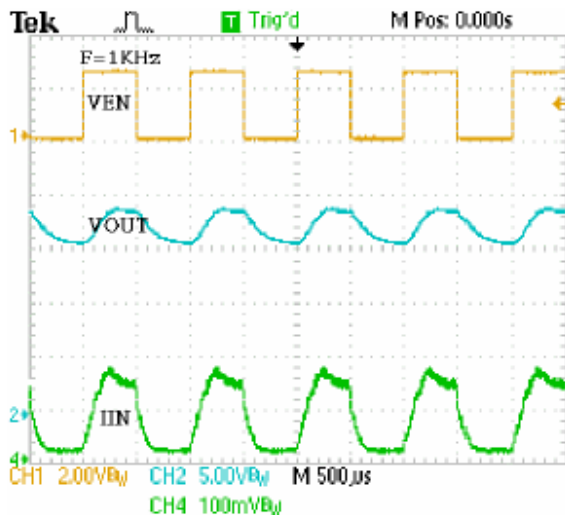

$V_{IN}=3.6V$  Driving 6LEDs 10KHz PWM Dimming

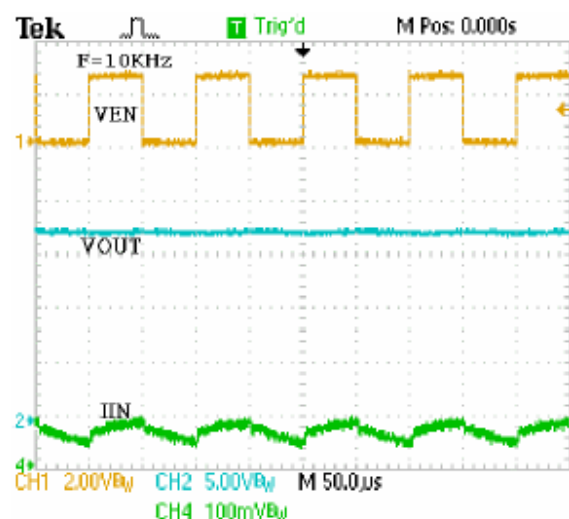

$V_{IN}=3.6V$  Driving 6LEDs 100KHz PWM Dimming

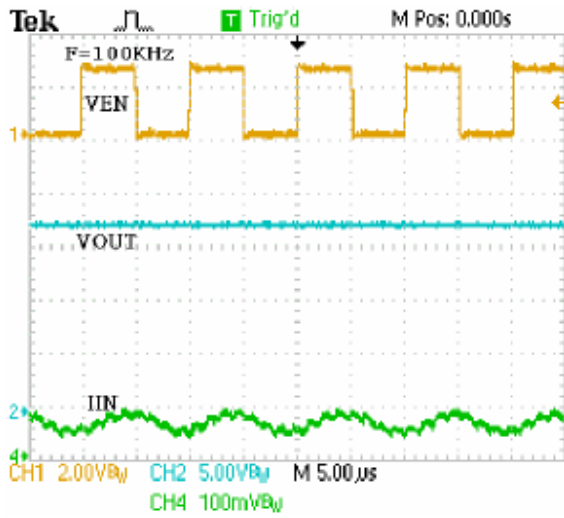

## Applications Information

### LED Current Control

The LP3302 regulates the LED current by setting the current sense resistor (R2) connecting to feedback and ground. The internal feedback reference voltage is 0.25V. The LED current can be set from following equation easily.

$$R2 = 0.25V / I_{LED} \text{-----(1)}$$

In order to have an accurate LED current, precision resistors are preferred (1% is recommended). The table for R2 selection is shown below.

R2 Resistor Value selection

I <sub>LED</sub> (mA)	R2 (Ω)
5	50
10	25
12	21
15	16.7
20	12.5

### Inductor Selection

The recommended value of inductor for 2 to 6 WLEDs applications are 4.7 to 22μH. Small size and better efficiency are the major concerns for portable device, such as LP3302 used for mobile phone. The inductor should have low core loss at 1.1MHz and low DCR for better efficiency. To avoid inductor saturation current rating should be considered.

## Dimming control

### a. Using a PWM Signal to EN Pin

To control the brightness of LED, the LP3302 can perform the dimming control by applying a PWM signal to EN pin. The internal soft-start and wide range dimming frequency from 100Hz to 100KHz can insignificantly reduce audio noise when dimming. The average LED current is proportional to the PWM signal duty cycle. The magnitude of the PWM signal should be higher than the maximum enable voltage of EN pin, in order to let the dimming control perform correctly.

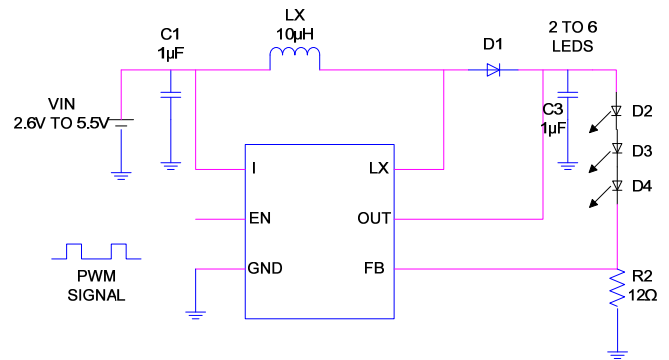

### b. Using a DC Voltage

Using a variable DC voltage to adjust the brightness is a popular method in some applications. The dimming control using a DC voltage circuit is shown in Figure 4. According to the Superposition Theorem, as the DC voltage increases, the voltage contributed to VFB increases and the voltage drop on R2 decreases, i.e. the LED current decreases. For example, if the VDC range is from 0V to 2.8V, the selection of resistors in Figure 4 sets dimming control of LED current from 20mA to 0mA.

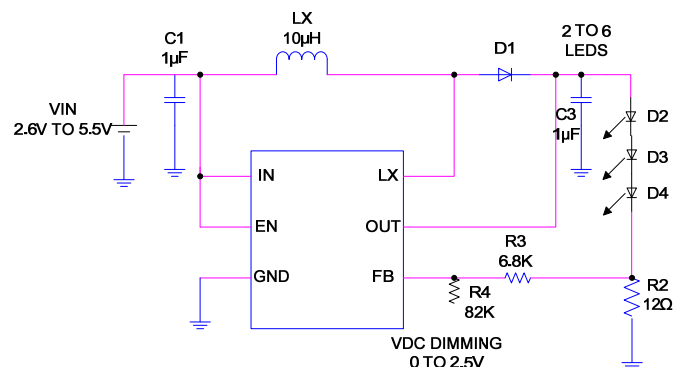

c. Using a Filtered PWM signal

Another common application is using a filtered PWM signal as an adjustable DC voltage for LED dimming control. A filtered PWM signal acts as the DC voltage to regulate the output current. The recommended application circuit is shown in the Figure 6. In this circuit, the output ripple depends on the frequency of PWM signal. For smaller output voltage ripple (<100mV), the recommended frequency of 2.8V PWM

signal should be above 2kHz. To fix the frequency of PWM signal and change the duty cycle of PWM signal can get different output current. According to the application circuit of Figure 5, output current is from 20.5mA to 5.5mA by adjusting the PWM duty cycle from 10% to 90%.

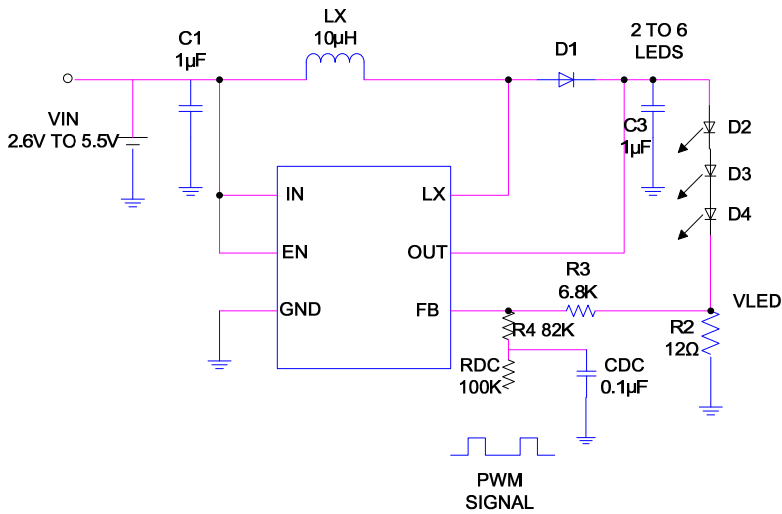

## Package Information

SOT23-6

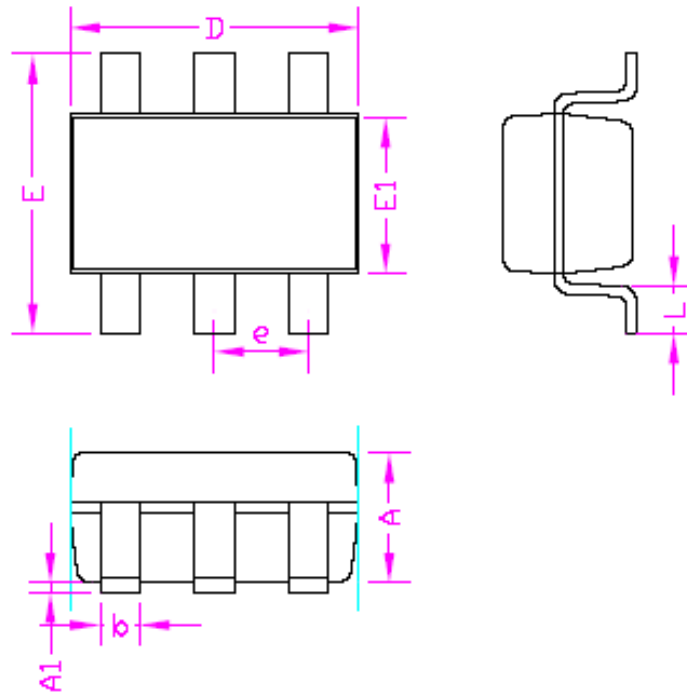

SYMBOLS	MILLIMETERS		INCHES	
	MIN.	MAX.	MIN.	MAX.
A	-	1.45	-	0.057
A1	0.00	0.15	0.000	0.006
b	0.30	0.50	0.012	0.020
D	2.90		0.114	
E1	1.60		0.063	
e	0.95		0.037	
E	2.60	3.00	0.102	0.118
L	0.3	0.60	0.012	0.024