

KBJ25005 THRU KBJ2510

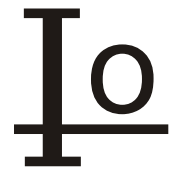

SINGLE PHASE 25.0 AMP BRIDGE RECTIFIERS

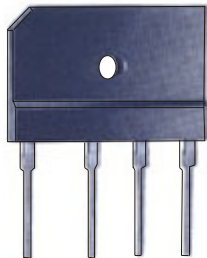

FEATURES

- * Superior thermal design
- * 400 amperes surge capability
- * Mounting: Hole thru for #8 screw
- * 1/4" universal faston terminal
- * Lead Free Finish/RoHS Compliant

VOLTAGE RANGE

50 to 1000 Volts

CURRENT

25.0 Ampere

KBJ

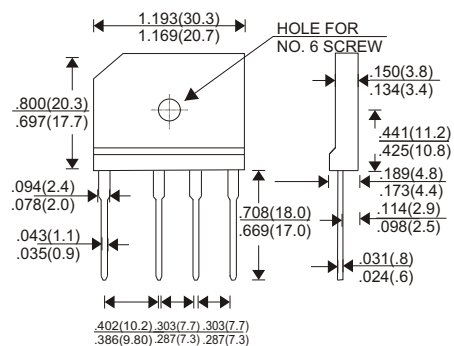

MAXIMUM RATINGS AND ELECTRICAL CHARACTERISTICS

Rating 25°C ambient temperature unless otherwise specified.
 Single phase half wave, 60Hz, resistive or inductive load.
 For capacitive load, derate current by 20%.

TYPE NUMBER	KBJ25005	KBJ2501	KBJ2502	KBJ2504	KBJ2506	KBJ2508	KBJ2510	UNITS	
Maximum Recurrent Peak Reverse Voltage	50	100	200	400	600	800	1000	V	
Maximum RMS Voltage	35	70	140	280	420	560	700	V	
Maximum DC Blocking Voltage	50	100	200	400	600	800	1000	V	
Maximum Average Forward Rectified Current									
.375" (9.5mm) Lead Length at Tc=55°C								25	A
Peak Forward Surge Current, 8.3 ms single half sine-wave superimposed on rated load (JEDEC method)								350	A
Maximum Forward Voltage Drop per Bridge Element at 12.5AD.C.								1.1	V
Maximum DC Reverse Current Ta=25°C								10	uA
at Rated DC Blocking Voltage Ta=100°C								500	uA
Operating Temperature Range, Tj								-55 — +125	°C
Storage Temperature Range, TSTG								-55 — +150	°C

RATING AND CHARACTERISTIC CURVES (KBJ25005 THRU KBJ2510)

FIG.1-TYPICAL FORWARD CURRENT DERATING CURVE

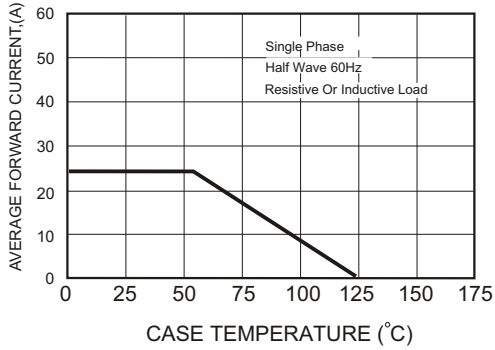

FIG.2-MAXIMUM NON-REPETITIVE FORWARD SURGE CURRENT

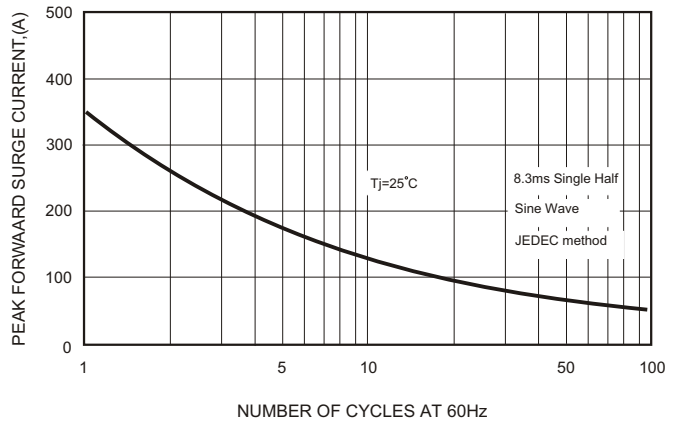

FIG.3-TYPICAL FORWARD CHARACTERISTICS

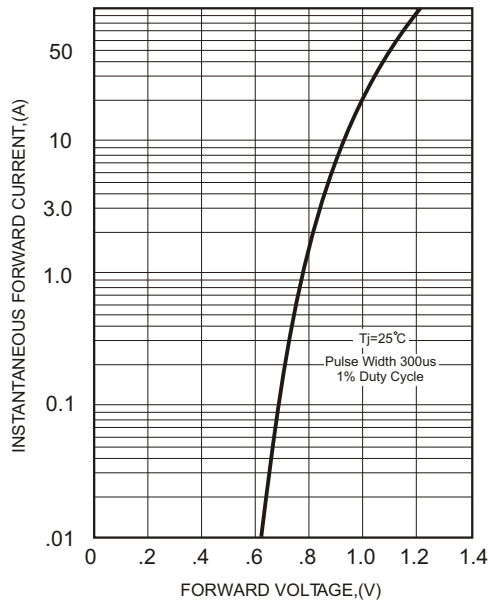

FIG.4-TYPICAL REVERSE CHARACTERISTICS

