

**3W STEREO CLASS-D with DC VOLUME,
POWER LIMIT and ANTI-SATURATION**

Description

The PAM8008 is a 3W, Class-D audio amplifier. Advanced 64-step DC volume control minimizes external components and allows speaker volume control.

Integrated power limit technology which suppress the output signal clip automatically due to the over level input signal. It offers low THD+N and protect speaker.

Integrated anti-saturation technology which suppress the output signal clip automatically when supply voltage changes. It offers low THD+N, to produce high-quality sound reproduction.

PAM8008 has an additional noise reduction circuit which achieves 6dB noise attenuation. This circuit may help eliminate external filtering, thereby saving the board space and components cost.

The PAM8008 features SCP (short circuit protection), OTP and thermal shutdown.

The PAM8008 is available in SOP-16L package.

Features

- 3W Output at 10% THD with a 4 Load and 5V Power Supply
- 2.4W Output at 1% THD with a 4 Load and 5V Power Supply
- Filterless, Low Quiescent Current and Low EMI
- Low THD+N
- Power Limit Function to Protect Speaker when Occuring Large Input
- 64-Step DC Volume Control from -80dB to +20dB
- 6dB Effective Noise Reduction
- Superior Low Noise: 60 μ V
- Minimize Pop/Clip Noise
- High Efficiency Up to 90%
- Auto Recovery Short Circuit Protection
- Thermal Shutdown
- Pb-Free Package

Pin Assignments

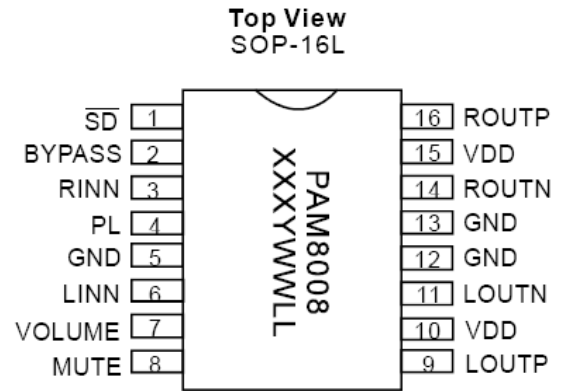

Applications

- LCD Monitors / TV Projectors
- Notebook/All-In-One Computers
- Portable Speakers
- Portable DVD Players, Game Machines

Typical Applications Circuit

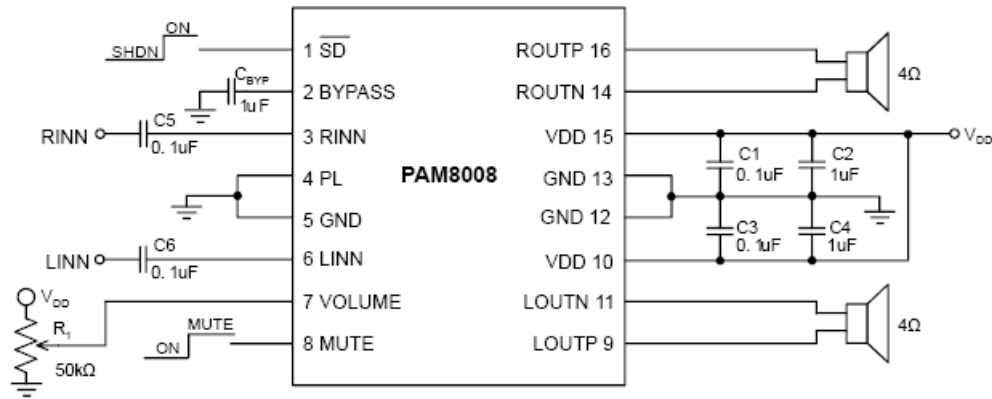

Pin Descriptions

| Pin Number | Pin Name | Function |
|------------|----------|---|
| 1 | SD | Full Chip Shutdown Control Input (active low). |
| 2 | BYPASS | Bias Voltage for Power Amplifiers. |
| 3 | RINN | Negative Input of Right Channel Power Amplifier. |
| 4 | PL | Connect PL to GND for Power Limit Setting. |
| 5, 12, 13 | GND | Ground Connection. |
| 6 | LINN | Negative Input of Left Channel Power Amplifier. |
| 7 | VOLUME | DC Volume Control to Set the Gain of Class-D. |
| 8 | MUTE | Mute Control Input (active high). |
| 9 | LOUTP | Positive Output of Left Channel Power Amplifier. |
| 10, 15 | VDD | Power Supply. |
| 11 | LOUTN | Negative Output of Left Channel Power Amplifier. |
| 14 | ROUTN | Negative Output of Right Channel Power Amplifier. |
| 16 | ROUTP | Positive Output of Right Channel Power Amplifier. |

Functional Block Diagram

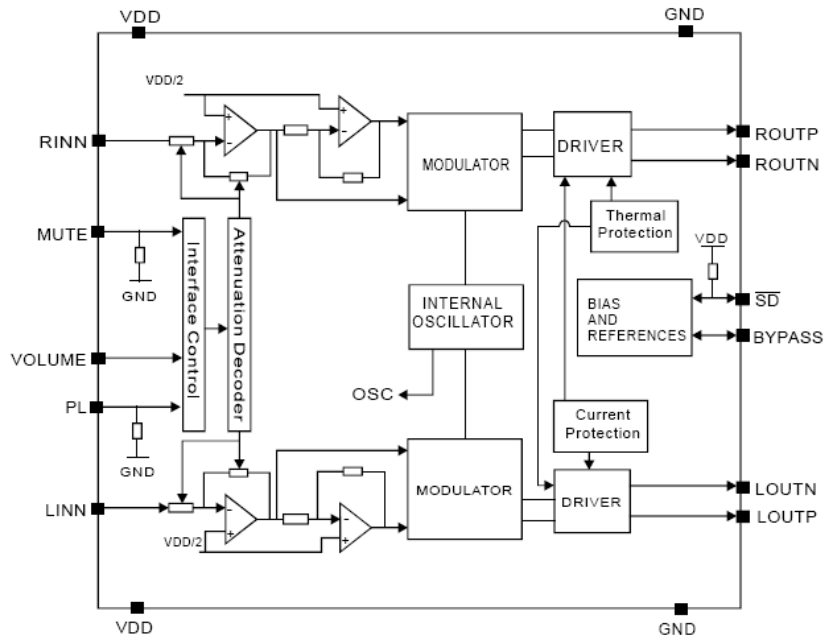

Absolute Maximum Ratings (@T_A = +25°C, unless otherwise specified.)

These are stress ratings only and functional operation is not implied. Exposure to absolute maximum ratings for prolonged time periods may affect device reliability. All voltages are with respect to ground.

| Parameter | Rating | Unit |
|----------------------------------|------------------------------|------|
| Supply Voltage | 6.0 | V |
| Input Voltage | -0.3 to V _{DD} +0.3 | |
| Operational Junction Temperature | -40 to +125 | °C |
| Storage Temperature | -65 to +150 | |
| Soldering Temperature | 300, 5 sec | |

Recommended Operating Conditions (@T_A = +25°C, unless otherwise specified.)

| Parameter | Rating | Unit |
|-------------------------------------|-------------|------|
| Supply Voltage Range | 2.5 to 5.5 | V |
| Ambient Operation Temperature Range | -20 to +85 | °C |
| Junction Temperature Range | -20 to +125 | |

Thermal Information

| Parameter | Package | Symbol | Max | Unit |
|--|---------|-----------------|-----|------|
| Thermal Resistance (Junction to Ambient) | SOP-16L | θ _{JA} | 110 | °C/W |
| Thermal Resistance (Junction to Case) | SOP-16L | θ _{JC} | 23 | |

Electrical Characteristics (@T_A = +25°C, V_{DD} = 5V, Gain = Maximum, R_L = 8Ω, unless otherwise specified.)

| Parameter | Symbol | Test Conditions | Min | Typ | Max | Units |
|--------------------------------------|---------------------|---|---------------------|------|-----|-------|
| Supply Voltage Range | V _{DD} | | 2.5 | | 5.5 | V |
| Quiescent Current | I _Q | No Load | | 8 | | mA |
| Output Offset Voltage | V _{OS} | No Load | | 10 | | mV |
| Drain-Source On-State Resistance | R _{DS(ON)} | I _{DS} = 0.5A | P MOSFET | 0.31 | | Ω |
| | | | N MOSFET | 0.21 | | |
| Output Power | P _O | THD+N = 1% f = 1kHz | R _L = 8Ω | 1.4 | | W |
| | | | R _L = 4Ω | 2.4 | | |
| Total Harmonic Distortion Plus Noise | THD+N | R _L = 8Ω, P _O = 0.85W, f = 1KHz | | 0.08 | | % |
| | | R _L = 4Ω, P _O = 1.75, f = 1KHz | | 0.08 | | |
| Power Supply Ripple Rejection | PSRR | Input AC-GND, f = 1KHz, V _{PP} = 200mV | | 70 | | dB |
| Channel Separation | CS | P _O = 1W, f = 1KHz | | -95 | | dB |
| Oscillator Frequency | f _{OSC} | | 200 | 250 | 300 | kHz |
| Efficiency | η | P _O = 1.1W, f = 1 kHz, R _L = 8Ω | | 87 | | % |
| | | P _O = 2.4W, f = 1 kHz, R _L = 4Ω | | 83 | | % |
| Noise | V _N | Input AC-GND | A-Weighting | 60 | | μV |
| | | | No A-Weighting | 80 | | |
| Signal Noise Ratio | SNR | f = 20 - 20kHz, THD = 1% | | 95 | | dB |
| Turn-On Time | T _{ON} | V _{DD} = 5V, C _{BYP} = 1μF | | 1.2 | | S |
| Mute Current | I _{MUTE} | MUTE = V _{DD} | | 4 | 10 | mA |
| Shutdown Current | I _{SD} | V _{SD} = 0V | | | 1 | μA |
| Logic Input High | V _{IH} | | 1.4 | | | V |
| Logic Input Low | V _{IL} | | | | 0.6 | |
| Over Temperature Protection | OTP | | | 150 | | °C |
| Over Temperature Hysteresis | OTH | | | 40 | | °C |

Typical Performance Characteristics (@ $T_A = +25^\circ\text{C}$, $V_{DD} = 5\text{V}$, $G_V = 20\text{dB}$, $R_L = 8\Omega$, unless otherwise specified.)

1. THD+N vs Output Power

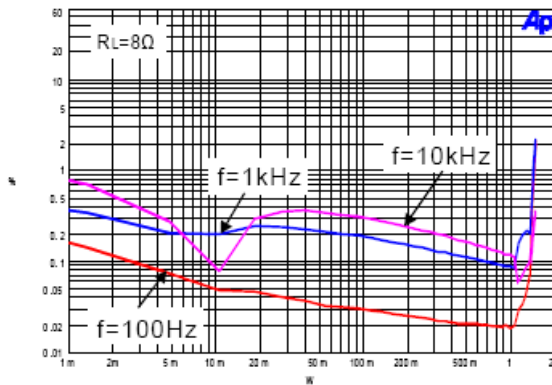

2. THD+N vs Output Power

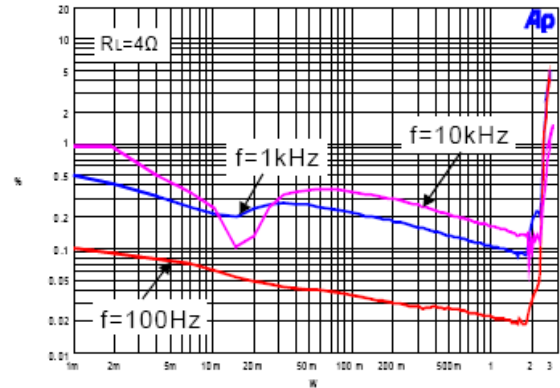

3. THD+N vs Frequency

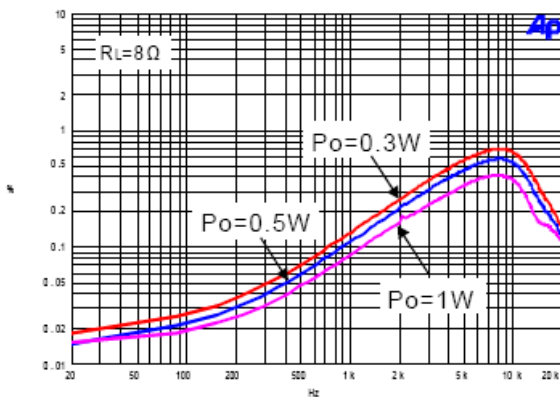

4. THD+N vs Frequency

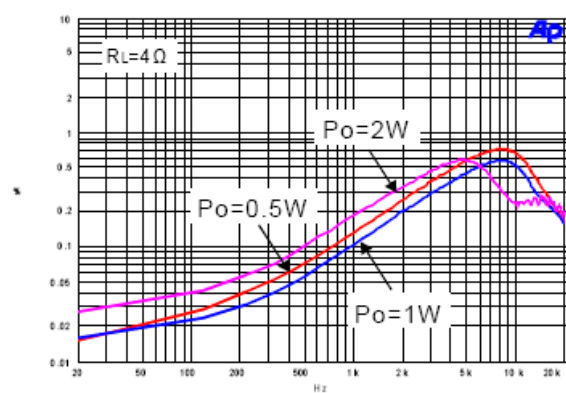

5. PSRR vs Frequency

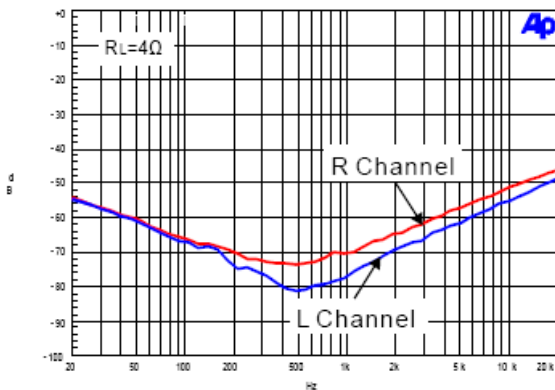

6. Crosstalk vs Frequency

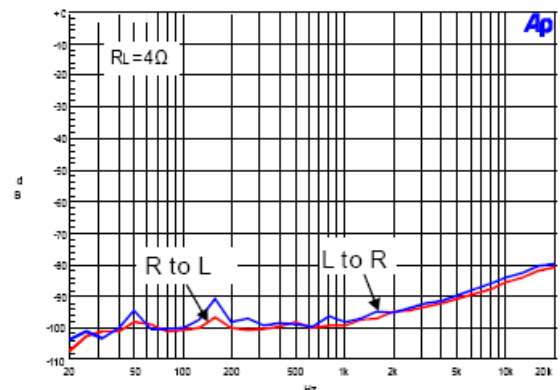

Typical Performance Characteristics (cont.) (@ $T_A = +25^\circ\text{C}$, $V_{DD} = 5\text{V}$, $G_V = 20\text{dB}$, $R_L = 8\Omega$, unless otherwise specified.)

7. Frequency Response

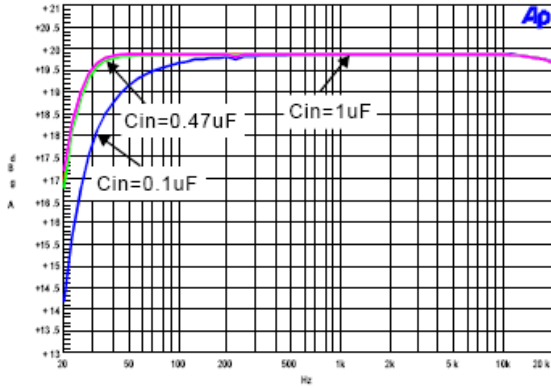

8. Noise Floor

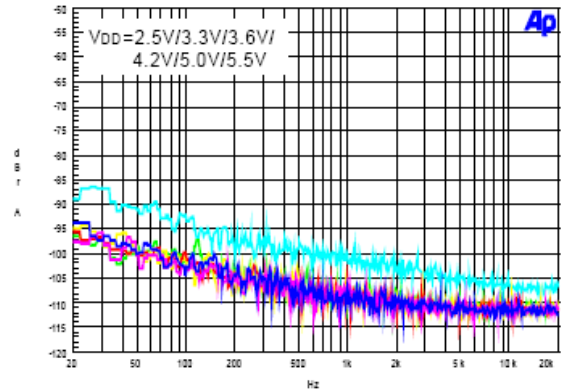

9. Efficiency VS Output Power

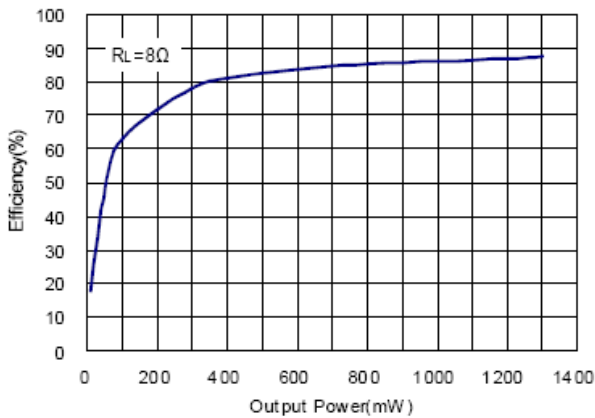

10. Efficiency VS Output Power

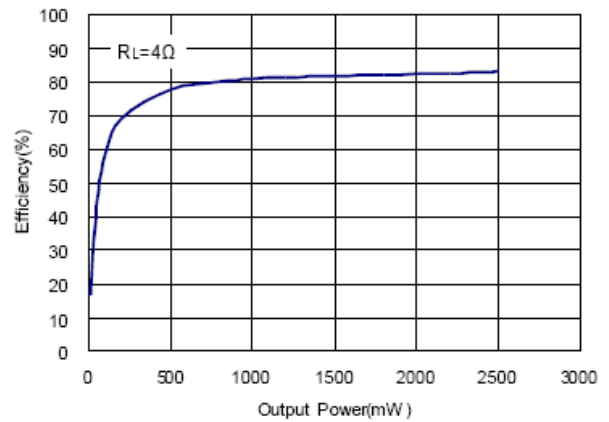

11. Output Power VS Supply Voltage

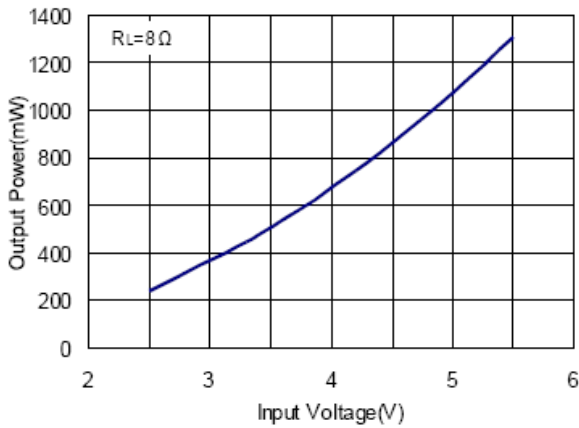

12. Output Power VS Supply Voltage

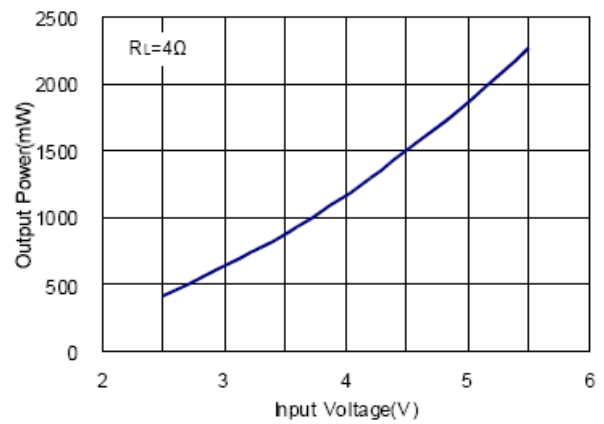

Typical Performance Characteristics (cont.) (@ $T_A = +25^\circ\text{C}$, $V_{DD} = 5\text{V}$, $G_V = 20\text{dB}$, $R_L = 8\Omega$, unless otherwise specified.)

13. Quiescent Current

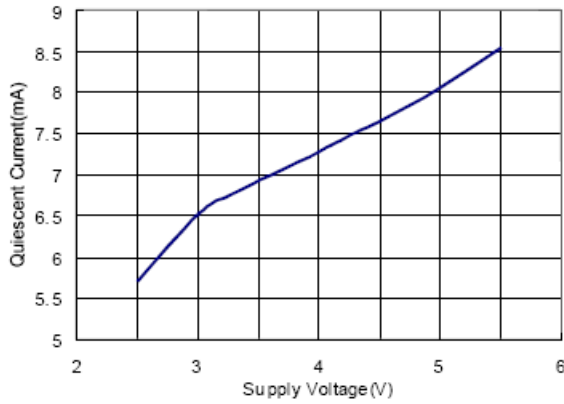

14. Switching Frequency VS Supply Voltage

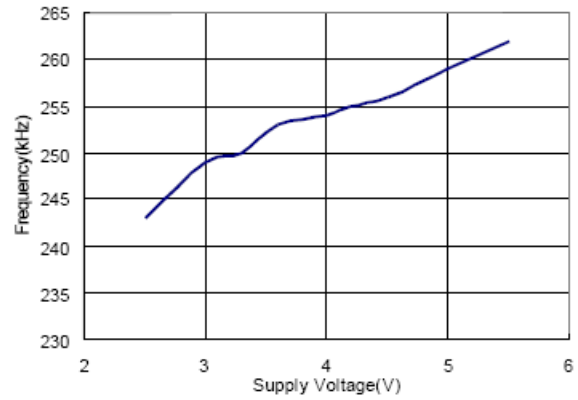

15. $R_{ds(on)}$ VS Output Current

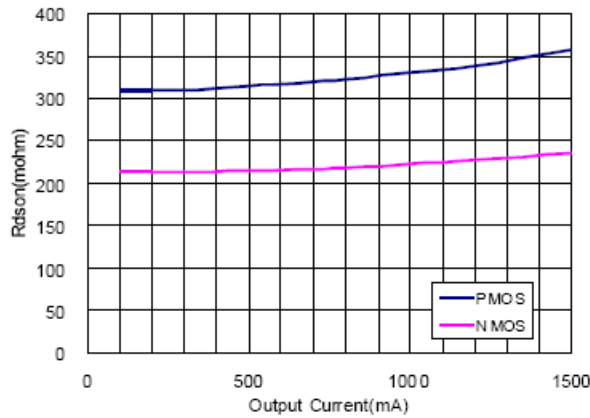

16. Power Limit Function

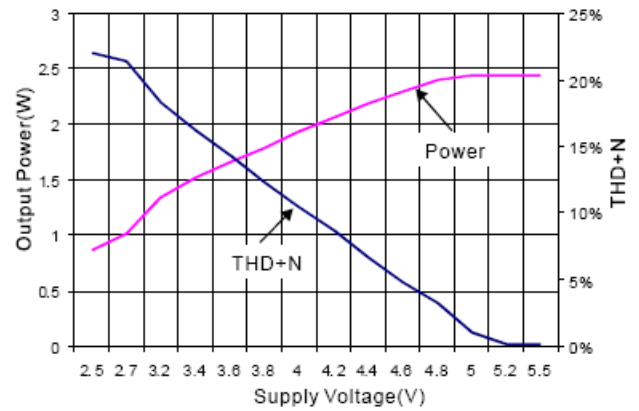

17. Anti-saturation Function

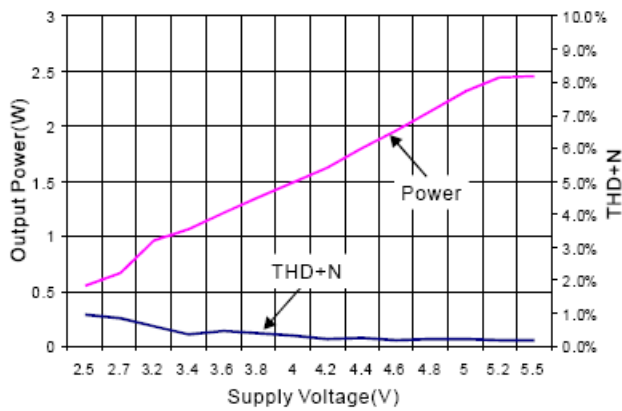

Typical Performance Characteristics (cont.) (@ $T_A = +25^\circ\text{C}$, $V_{DD} = 5\text{V}$, $G_V = 20\text{dB}$, $R_L = 8\Omega$, unless otherwise specified.)

Table 1. DC Volume Control

| STEP | Gain (dB) | Volume (V) | STEP | Gain (dB) | Volume (V) |
|------|-----------|----------------|------|-----------|----------------|
| 1 | 19.84 | 0 to 0.201 | 33 | 6.60 | 2.461 to 2.533 |
| 2 | 19.42 | 0.201 to 0.275 | 34 | 6.24 | 2.533 to 2.605 |
| 3 | 19.00 | 0.275 to 0.347 | 35 | 5.88 | 2.605 to 2.678 |
| 4 | 18.60 | 0.347 to 0.419 | 36 | 5.51 | 2.678 to 2.751 |
| 5 | 18.21 | 0.419 to 0.491 | 37 | 5.16 | 2.751 to 2.823 |
| 6 | 17.83 | 0.491 to 0.563 | 38 | 4.79 | 2.823 to 2.897 |
| 7 | 17.46 | 0.563 to 0.633 | 39 | 4.43 | 2.897 to 2.969 |
| 8 | 16.92 | 0.633 to 0.701 | 40 | 4.06 | 2.969 to 3.043 |
| 9 | 16.40 | 0.701 to 0.771 | 41 | 3.70 | 3.043 to 3.114 |
| 10 | 15.90 | 0.771 to 0.849 | 42 | 3.33 | 3.114 to 3.186 |
| 11 | 15.41 | 0.849 to 0.929 | 43 | 2.96 | 3.186 to 3.259 |
| 12 | 14.93 | 0.929 to 1.005 | 44 | 2.58 | 3.259 to 3.332 |
| 13 | 14.47 | 1.005 to 1.079 | 45 | 2.21 | 3.332 to 3.403 |
| 14 | 14.02 | 1.079 to 1.153 | 46 | 1.83 | 3.403 to 3.476 |
| 15 | 13.58 | 1.153 to 1.225 | 47 | 1.44 | 3.476 to 3.551 |
| 16 | 13.15 | 1.225 to 1.297 | 48 | 1.05 | 3.551 to 3.621 |
| 17 | 12.72 | 1.297 to 1.371 | 49 | 0.66 | 3.621 to 3.695 |
| 18 | 12.30 | 1.371 to 1.443 | 50 | 0.26 | 3.695 to 3.767 |
| 19 | 11.89 | 1.443 to 1.517 | 51 | -0.14 | 3.767 to 3.839 |
| 20 | 11.49 | 1.517 to 1.589 | 52 | -1.19 | 3.839 to 3.909 |
| 21 | 11.09 | 1.589 to 1.661 | 53 | -2.27 | 3.909 to 3.979 |
| 22 | 10.70 | 1.661 to 1.733 | 54 | -3.19 | 3.979 to 4.045 |
| 23 | 10.31 | 1.733 to 1.807 | 55 | -5.18 | 4.045 to 4.116 |
| 24 | 9.92 | 1.807 to 1.879 | 56 | -7.16 | 4.116 to 4.195 |
| 25 | 9.55 | 1.879 to 1.951 | 57 | -9.11 | 4.195 to 4.273 |
| 26 | 9.17 | 1.951 to 2.025 | 58 | -11.01 | 4.273 to 4.347 |
| 27 | 8.80 | 2.025 to 2.097 | 59 | -17.13 | 4.347 to 4.421 |
| 28 | 8.42 | 2.097 to 2.169 | 60 | -22.95 | 4.421 to 4.493 |
| 29 | 8.06 | 2.169 to 2.243 | 61 | -29.07 | 4.493 to 4.565 |
| 30 | 7.69 | 2.243 to 2.315 | 62 | -33.50 | 4.565 to 4.637 |
| 31 | 7.33 | 2.315 to 2.389 | 63 | -39.33 | 4.637 to 4.708 |
| 32 | 6.69 | 2.389 to 2.461 | 64 | -58.62 | 4.708 to Max |

Application Information

Power Limit Function

When connect Pin 4 to GND or floating, the PAM8008 power is limited at 2.5W. Different from other company's power limit, the power limit circuit of PAM8008 sets a limit on the output peak voltage, and the value is lower than the supply voltage (V_{DD}), it means the THD+N always lower than 10% when power limit works. When the PAM8008 enters in power limit mode, the gain changes depending on the input audio signal amplitude and the attack, release time. The gain changes constantly as the audio signal increase or decrease. Every gain step size is about 0.4dB. If the audio signal has near-constant amplitude or the maximum attenuation is 20dB, the gain does not change.

Anti-Saturation Function

When connect Pin 4 to high, the PAM8008 enters power limit or anti-saturation mode. Which mode is selected depending on V_{DD} and input audio signal amplitude. If the $V_{DD} \leq 5V$, it enters anti-saturation mode. If the $V_{DD} > 5V$, it enters power limit mode. In anti-saturation mode, the power is 2.3W and the THD+N is lower than 1% when $V_{DD} = 5V$. If connect Pin 4 to $V_{DD}/2$, it can disable power limit and antisaturation function.

Table 2. PAM8008 Power Limit and Anti-Saturation Variable Description

| Variable | Description | Value |
|--------------|---|-------------------|
| Gain | The max gain when the PAM8008 is not in power limit and anti-saturation mode. | 20dB (Maximum) |
| Attack Time | The minimum time between two gain decrements. | 128 μ s |
| Release Time | The minimum time between two gain increments. | 256mS |

Table 3. PAM8008 Power Limit and Anti-Saturation Mode Setting

| PL | Mode |
|-------------------------------------|---|
| PL = Floating or PL = 0V to 0.2V | Power Limit |
| PL = 0.8V to $V_{DD}/2$ | Power Limit and Anti-Saturation Off |
| PL = 3.8V to VDD | $V_{DD} > 5V$, Power Limit $V_{DD} \leq 5V$, Anti-Saturation |

Noise Reduction Function

The gain of PAM8008 will reduce 6dB when there is no audio at the input of the amplifier for 8s. The gain will recover until the input signal is above the noise threshold. The noise threshold is set by internal voltage.

Mute Operation

The MUTE pin is an input for controlling the Class-D output state of the PAM8008. A logic low on this pin enables the outputs, and a logic high on this pin disables the outputs. This pin may be used as a quick disable or enable of the outputs without a volume fade. Quiescent current is listed in the electrical characteristic table. The MUTE pin can be left floating due to the internal pull-down.

Shutdown Operation

In order to reduce power consumption while not in use, the PAM8008 contains shutdown circuit to turn off the amplifier's bias circuit. The amplifier is turned off when logic low is placed on the SD pin. By connecting the SD pin to GND, the PAM8008 supply current will be minimized in idle mode. The SD pin can be left floating due to the internal pull-up.

For the best power on/off pop performance, the amplifier should be placed in the Mute mode prior to turning on/off the power supply.

Application Information (cont.)

Power Supply Decoupling

The PAM8008 is a high performance CMOS audio amplifier that requires adequate power supply decoupling to ensure the output THD and PSRR as low as possible. Power supply decoupling also prevents oscillations caused by long lead between the amplifier and the speaker. The optimum decoupling is achieved by using two capacitors of different types that target different types of noise on the power supply leads. For higher frequency transients, spikes, or digital hash on the line, a good low equivalent series resistance (ESR) ceramic capacitor, typically 0.1µF, is recommended, placing as close as possible to the device's V_{DD} lead. For filtering lower-frequency noise signals, a large capacitor of 10µF (ceramic) or greater placed near the audio power amplifier is recommended.

Input Capacitor (C_I)

Large input capacitors are both expensive and space hungry for portable designs. Clearly, a certain sized capacitor is needed to couple in low frequencies without severe attenuation. But in many cases the speakers used in portable systems, whether internal or external, have little ability to reproduce signals below 100Hz to 150Hz. Thus, using a large input capacitor may not increase actual system performance. In this case, input capacitor (C_I) and input resistance (R_I) of the amplifier form a high-pass filter with the corner frequency determined equation below,

$$f_c = \frac{1}{2\pi R_I C_I}$$

In addition to system cost and size, click and pop performance is affected by the size of the input coupling capacitor requires more charge to reach its quiescent DC voltage (normally ½ V_{DD}). This charge comes from the internal circuit via the feedback and is apt to create pops upon device enable. Thus, by minimizing the capacitor size based on necessary low frequency response, turn-on pops can be minimized.

Analog Reference Bypass Capacitor (C_{BYP})

Analog Reference Bypass Capacitor (C_{BYP}) is the most critical capacitor and serves several important functions. During start-up or recovery from shutdown mode, C_{BYP} determines the rate at which the amplifier starts up. The second function is to reduce noise produced by the power supply caused by coupling into the output drive signal. This noise is from the internal analog reference to the amplifier, which appears as degraded PSRR and THD+N.

A ceramic bypass capacitor (C_{BYP}) of 0.47µF to 1.0µF is recommended for the best THD and noise performance. Increasing the bypass capacitor reduces clicking and popping noise from power on/off and entering and leaving shutdown.

Under Voltage Lock-Out

The PAM8008 incorporates circuitry designed to detect when the supply voltage is low. When the supply voltage drops to 2.2V or below, the PAM8008 outputs are disabled, and the device comes out of this state and starts to normal functional once V_{DD} ≥ 2.4V.

Short Circuit Protection (SCP)

The PAM8008 has short circuit protection circuitry on the outputs that prevents the device from damage when output-to-output and output-to-GND short. When a short circuit is detected on the outputs, the outputs are disabled immediately. If the short was removed, the device activates again.

Over Temperature Protection

Thermal protection on the PAM8008 prevents the device from damage when the internal die temperature exceeds +150°C. There is a 15 degree tolerance on this trip point from device to device. Once the die temperature exceeds the thermal set point, the device outputs are disabled. This is not a latched fault. The thermal fault is cleared once the temperature of the die is reduced by +40°C. This large hysteresis will prevent motor boating sound well. The device begins normal operation at this point without external system interaction.

How to Reduce EMI (Electro Magnetic Interference)

A simple solution is to put an additional capacitor 1000µF at power supply terminal for power line coupling if the traces from amplifier to speakers are short (< 20CM).

Application Information (cont.)

How to Reduce EMI (Electro Magnetic Interference) (cont.)

Most applications required a ferrite bead filter as shown at Figure 1. The ferrite filter reduces EMI around 1MHz and higher. When selecting a ferrite bead, choose one with high impedance at high frequencies, and low impedance at low frequencies (MH2012HM221-T).

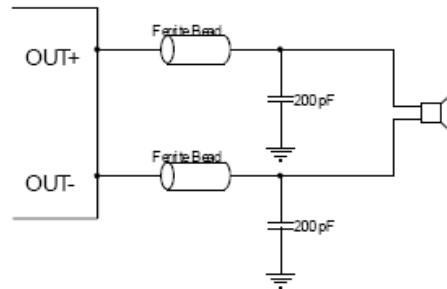

Figure 1: Ferrite Bead Filter to Reduce EMI

PCB Layout Guidelines Grounding

At this stage it is paramount to notice the necessity of separate grounds. Noise currents in the output power stage need to be returned to output noise ground and nowhere else. Were these currents to circulate elsewhere, they may get into the power supply, the signal ground, etc, worse yet, they may form a loop and radiate noise. Any of these cases results in degraded amplifier performance. The logical returns for the output noise currents associated with Class-D switching are the respective GND pins for each channel. The switch state diagram illustrates that GND is instrumental in nearly every switch state. This is the perfect point to which the output noise ground trace should return. Also note that output noise ground is channel specific. A two channel amplifier has two separate channels and consequently must have two separate output noise ground traces. The layout of the PAM8008 offers separate GND connections for each channel and in some cases each side of the bridge. Output noise grounds must be tied to system ground at the power in exclusively. Signal currents for the inputs, reference, etc need to be returned to quiet ground. This ground is only tied to the signal components and the GND pin, and GND then tied to system ground.

Test Setup for Performance Testing (Class D)

1. When the PAM8008 works with LC filters, it should be connected with the speaker before it's powered on, otherwise it will be damaged easily.
2. When the PAM8008 works without LC filters, it's better to add a ferrite chip bead at the outgoing line of speaker for suppressing the possible electromagnetic interference.
3. The absolute maximum rating of the PAM8008 operation voltage is 6.0V. When the PAM8008 is powered with four battery cells, it should be noted that the voltage of four new dry or alkaline batteries is over 6V, higher than its maximum operation voltage, which probably make the device damaged. Therefore, it's recommended to use either four Ni-MH (Nickel Metal Hydride) rechargeable batteries or three dry or alkaline batteries.
4. The input signal should not be too high, if too high, it will cause the clipping of output signal when increasing the volume. Because the DC volume control of the PAM8008 has big gain, it will make the device damaged.
5. When testing the PAM8008 without LC filters b y using resistor instead of speaker as the output load, the test results, e.g. THD or efficiency, will be worse than those using speaker as load.

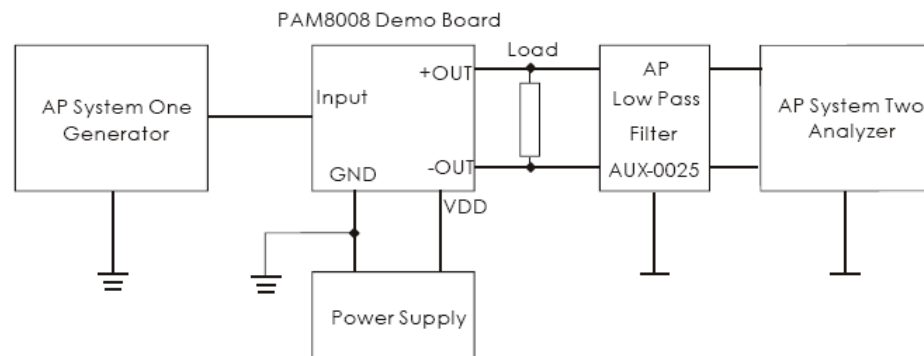

- Notes:
1. The AP AUX-0025 low pass filter is necessary for class-D amplifier measurement with AP analyzer.
 2. Two 22μH inductors are used in series with load resistor to emulate the small speaker for efficiency measurement.

Ordering Information

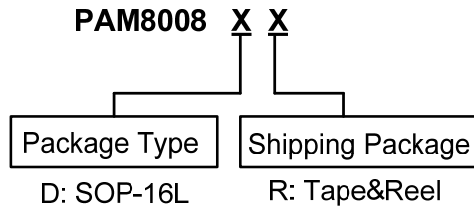

| Part Number | Package Type | Standard Package |
|-------------|--------------|----------------------|
| PAM8008DR | SOP-16L | 2500 Units/Tape&Reel |

Marking Information

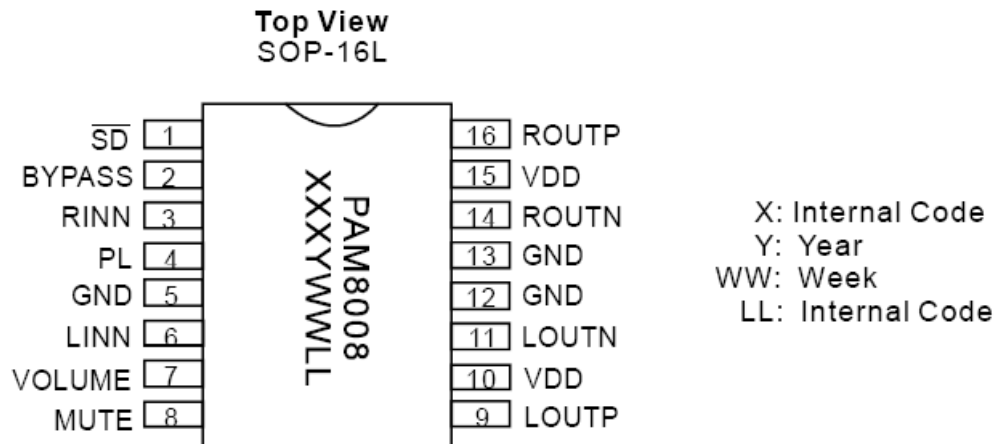

Package Outline Dimensions (All dimensions in mm.)

SOP-16L

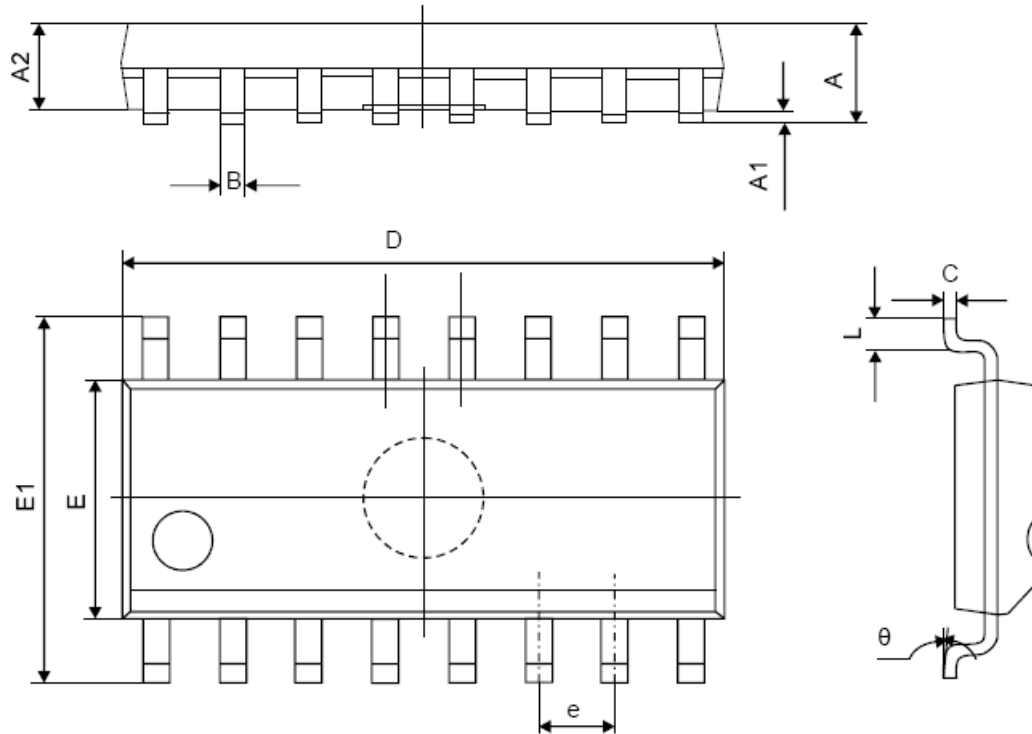

| Symbol | Dimensions Millimeters | |
|--------|------------------------|--------|
| | Min | Max |
| A | 1.350 | 1.750 |
| A1 | 0.100 | 0.250 |
| A2 | 1.350 | 1.550 |
| B | 0.330 | 0.510 |
| C | 0.190 | 0.250 |
| D | 9.800 | 10.000 |
| E | 3.800 | 4.000 |
| E1 | 5.800 | 6.300 |
| e | 1.270(TYP) | |
| L | 0.400 | 1.270 |
| θ | 0° | 8° |

IMPORTANT NOTICE

DIODES INCORPORATED MAKES NO WARRANTY OF ANY KIND, EXPRESS OR IMPLIED, WITH REGARDS TO THIS DOCUMENT, INCLUDING, BUT NOT LIMITED TO, THE IMPLIED WARRANTIES OF MERCHANTABILITY AND FITNESS FOR A PARTICULAR PURPOSE (AND THEIR EQUIVALENTS UNDER THE LAWS OF ANY JURISDICTION).

Diodes Incorporated and its subsidiaries reserve the right to make modifications, enhancements, improvements, corrections or other changes without further notice to this document and any product described herein. Diodes Incorporated does not assume any liability arising out of the application or use of this document or any product described herein; neither does Diodes Incorporated convey any license under its patent or trademark rights, nor the rights of others. Any Customer or user of this document or products described herein in such applications shall assume all risks of such use and will agree to hold Diodes Incorporated and all the companies whose products are represented on Diodes Incorporated website, harmless against all damages.

Diodes Incorporated does not warrant or accept any liability whatsoever in respect of any products purchased through unauthorized sales channel. Should Customers purchase or use Diodes Incorporated products for any unintended or unauthorized application, Customers shall indemnify and hold Diodes Incorporated and its representatives harmless against all claims, damages, expenses, and attorney fees arising out of, directly or indirectly, any claim of personal injury or death associated with such unintended or unauthorized application.

Products described herein may be covered by one or more United States, international or foreign patents pending. Product names and markings noted herein may also be covered by one or more United States, international or foreign trademarks.

This document is written in English but may be translated into multiple languages for reference. Only the English version of this document is the final and determinative format released by Diodes Incorporated.

LIFE SUPPORT

Diodes Incorporated products are specifically not authorized for use as critical components in life support devices or systems without the express written approval of the Chief Executive Officer of Diodes Incorporated. As used herein:

A. Life support devices or systems are devices or systems which:

1. are intended to implant into the body, or
2. support or sustain life and whose failure to perform when properly used in accordance with instructions for use provided in the labeling can be reasonably expected to result in significant injury to the user.

B. A critical component is any component in a life support device or system whose failure to perform can be reasonably expected to cause the failure of the life support device or to affect its safety or effectiveness.

Customers represent that they have all necessary expertise in the safety and regulatory ramifications of their life support devices or systems, and acknowledge and agree that they are solely responsible for all legal, regulatory and safety-related requirements concerning their products and any use of Diodes Incorporated products in such safety-critical, life support devices or systems, notwithstanding any devices- or systems-related information or support that may be provided by Diodes Incorporated. Further, Customers must fully indemnify Diodes Incorporated and its representatives against any damages arising out of the use of Diodes Incorporated products in such safety-critical, life support devices or systems.

Copyright © 2012, Diodes Incorporated

www.diodes.com