



BD246, A, B, C

PNP SINGLE-DIFFUSED MESA SILICON POWER TRANSISTORS

The BD246 series are PNP power transistors in a TO3PN envelope. They are the power transistors for power amplifier and high-speed-switching applications. The complementary is BD245, A, B, C. Compliance to RoHS.

ABSOLUTE MAXIMUM RATINGS

Symbol	Ratings	Value	Unit	
V_{CEO}	Collector-Emitter Voltage ($I_C = -30\text{mA}$)	BD246	-45	V
		BD246A	-60	
		BD246B	-80	
		BD246C	-100	
V_{CER}	Collector-Emitter Voltage ($R_{BE} = 100 \Omega$)	BD246	-55	V
		BD246A	-70	
		BD246B	-90	
		BD246C	-115	
V_{EBO}	Emitter-Base Voltage	-5.0	V	
I_C	Collector Current	I_C	-10	A
		I_{CM}	-15	
I_B	Base Current	-3	A	
P_T	Power Dissipation	$T_{mb} = 25^\circ \text{C}$	80	Watts
T_J	Junction Temperature		-65 to +150	°C
T_S	Storage Temperature		-65 to +150	

THERMAL CHARACTERISTICS

Symbol	Ratings	Value	Unit
R_{thJC}	Junction to Case Thermal Resistance	1.56	°C / W
R_{thJA}	Junction to free air Thermal Resistance	42	°C / W

BD246, A, B, C

ELECTRICAL CHARACTERISTICS

TC=25°C unless otherwise noted

Symbol	Ratings	Test Condition(s)	Min	Typ	Mx	Unit	
I_{CES}	Collector- Emitter Cut-off Current	$V_{CE} = -55 V, V_{BE} = 0$ BD246	-	-	-0.4	mA	
		$V_{CE} = -70 V, V_{BE} = 0$ BD246A					
		$V_{CE} = -90 V, V_{BE} = 0$ BD246B					
		$V_{CE} = -115 V, V_{BE} = 0$ BD246C					
I_{CEO}	Collector Cut-off Current	$V_{CE} = -30 V, I_B = 0$ BD246	-	-	-0.7	mA	
		BD246A					
		$V_{CE} = -60 V, I_B = 0$ BD246B					
		BD246C					
I_{EBO}	Emitter Cut-off Current	$V_{EB} = -5 V, I_C = 0$	-	-	-1	mA	
V_{CEO}	Collector- Emitter Breakdown Voltage (*)	$I_C = -30 mA, I_B = 0$	BD246	-45	-	-	V
			BD246A	-60	-	-	
			BD246B	-80	-	-	
			BD246C	-100	-	-	
h_{FE}	DC Current Gain (*)	$V_{CE} = -4 V, I_C = -1 A$	40	-	-	-	
		$V_{CE} = -4 V, I_C = -3 A$	20	-	-		
		$V_{CE} = -4 V, I_C = -10 A$	4	-	-		
$V_{CE(SAT)}$	Collector-Emitter saturation Voltage (*)	$I_C = -3 A, I_B = -300 mA$	-	-	-1	V	
		$I_C = -10 A, I_B = -2.5 A$	-	-	-4		
V_{BE}	Base-Emitter Voltage(*)	$V_{CE} = -4 V, I_C = -3 A$	-	-	-1.6	V	
		$V_{CE} = -4 V, I_C = -10 A$	-	-	-3		
h_{fe}	Small Signal forward Current Transfer ratio	$V_{CE} = -10 V, I_C = -500 mA, f = 1MHz$	20	-	-	-	
$ h_{fe} $	Small Signal forward Current Transfer ratio	$V_{CE} = -10 V, I_C = -500 mA, f = 1MHz$	3	-	-		

RESISTIVE-LOAD-SWITCHING CHARACTERISTICS AT 25°C CASE TEMPERATURE

Symbol	Ratings	Test Condition(s)	Min	Typ	Mx	Unit
t_{on}	Turn-on Time	$I_C = -1 A, I_{B(on)} = -100 mA, I_{B(off)} = 100 mA$ $V_{BE(off)} = 3.7 V, R_L = 20 \Omega, t_p = 20 \mu s$ dc < 2%	-	0.2	-	μs
t_{off}	Turn-off Time	$I_C = -1 A, I_{B(on)} = -100 mA, I_{B(off)} = 100 mA$ $V_{BE(off)} = 3.7 V, R_L = 20 \Omega, t_p = 20 \mu s$ dc < 2%	-	0.8	-	

BD246, A, B, C

MECHANICAL DATA CASE TO3PN Non Isolated Plastic Package

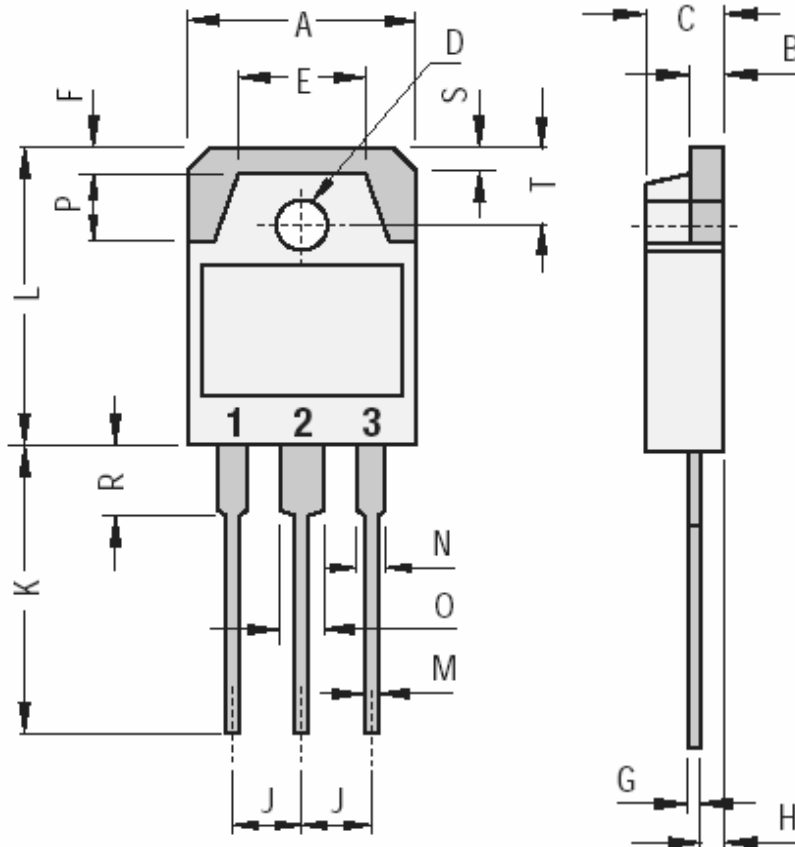

DIMENSIONS (mm)		
	Min.	Max.
A	15.20	16.00
B	1.90	2.10
C	4.60	5.00
D	3.10	3.30
E		9.60
F		2.00
G	0.35	0.55
H		1.40
J	5.35	5.55
K	20.00	
L	19.60	20.20
M	0.95	1.25
N		2.00
O		3.00
P		4.00
R		4.00
S		1.80
T	4.80	5.20

Pin 1 :	Base
Pin 2 :	Collector
Pin 3 :	Emitter

Revised August 2012

Information furnished is believed to be accurate and reliable. However, Comset Semiconductors assumes no responsibility for the consequences of use of such information nor for any infringement of patents or other rights of third parties which may result from its use. Data are subject to change without notice. Comset Semiconductors makes no warranty, representation or guarantee regarding the suitability of its products for any particular purpose, nor does Comset Semiconductors assume any liability arising out of the application or use of any product and specifically disclaims any and all liability, including without limitation consequential or incidental damages. Comset Semiconductors' products are not authorized for use as critical components in life support devices or systems.