

PRODUCT NO.

JSC 96356

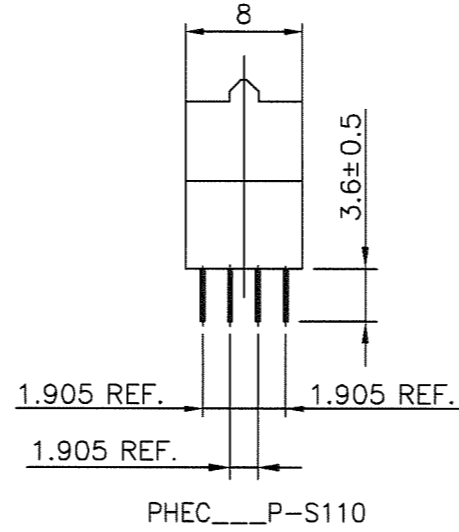

RECOMMENDED PC BOARD
THICKNESS: 1.6 ± 0.2
HOLE PATTERN (COMPONENT SIDE)

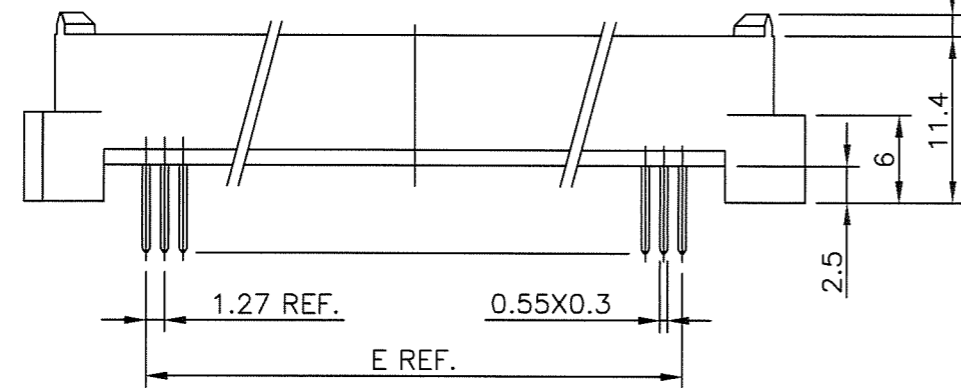
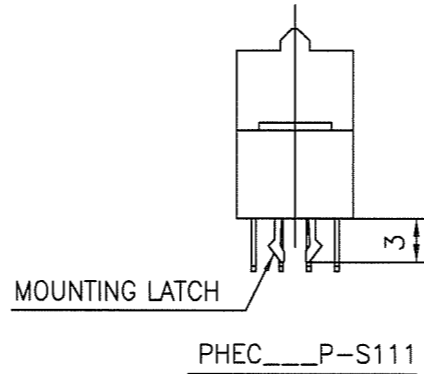
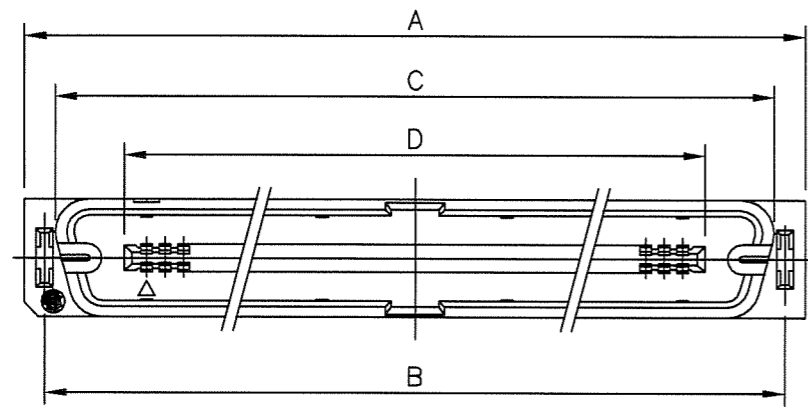
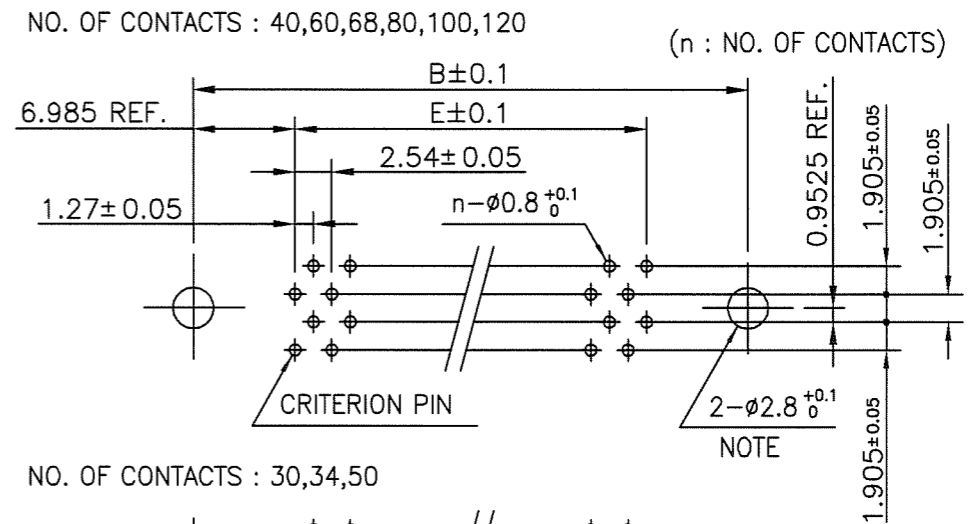

NOTE : THROUGH-HOLES FOR MOUNTING LATCHES ALSO SHOULD BE PLATED

NO. OF CONTACTS : 40,60,68,80,100,120

CRITERION PIN

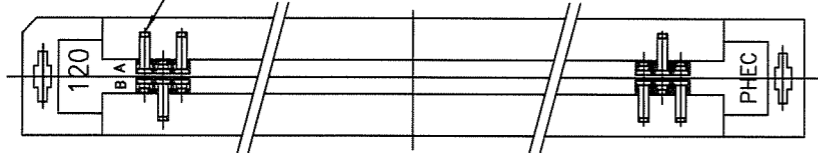

NO. OF CONTACTS : 30,34,50

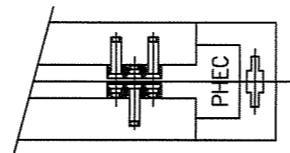

CAT. NO.	NO. OF CONTACTS (MATING SIDE)	DIMENSIONS				
		A	B	C	D	E
PHEC30P-S11_LF	15/ROW X 2 ROWS	34.55	31.75	30.30	20.42	17.78
PHEC34P-S11_LF	17/ROW X 2 ROWS	37.09	34.29	32.84	22.96	20.32
PHEC40P-S11_LF	20/ROW X 2 ROWS	40.90	38.10	36.65	26.77	24.13
PHEC50P-S11_LF	25/ROW X 2 ROWS	47.25	44.45	43.00	33.12	30.48
PHEC60P-S11_LF	30/ROW X 2 ROWS	53.60	50.80	49.35	39.47	36.83
PHEC68P-S11_LF	34/ROW X 2 ROWS	58.68	55.88	54.43	44.55	41.91
PHEC80P-S11_LF	40/ROW X 2 ROWS	66.30	63.50	62.05	52.17	49.53
PHEC100P-S11_LF	50/ROW X 2 ROWS	79.00	76.20	74.75	64.87	62.23
PHEC120P-S11_LF	60/ROW X 2 ROWS	91.70	88.90	87.45	77.57	74.93

NOTES

1. BODY MATERIAL : NYLON GLASS FILLED (UL94V-0), COLOR BLACK
2. TERMINAL MATERIAL : PHOSPHOR BRONZE
3. MOUNTING LATCH MATERIAL : PHOSPHOR BRONZE
4. TERMINAL FINISH
CONTACT AREA : GOLD FLASH 0.1µm min. OVER NICKEL UNDERLAYER
SOLDER TAILS : PURE Sn 2µm min. OVER NICKEL UNDERLAYER
5. MOUNTING LATCH FINISH : PURE Sn 2µm min. OVER NICKEL UNDERLAYER
6. THIS PRODUCT MEETS EUROPEAN UNION DIRECTIVES AND OTHER COUNTRY REGULATIONS AS DESCRIBED IN GS-22-008
7. THE HOUSING WILL WITHSTAND EXPOSURE TO 260 DEGREE PEAK TEMPERATURE FOR 10 SECONDS IN A WAVE SOLDER APPLICATION WITH A 1.6mm MINIMUM THICK CIRCUIT BOARD.

mat'l. code				surface ISO 1302		tolerance ISO 406 ISO 1101		projection		product family PHEC		CODE JP
---				ISO 1302		tolerances unless otherwise specified		MM		title		
ltr	description	ecn no	dr	date	angles	linear	0.X ±0.3	MM		PRINTED CIRCUIT CONNECTOR		
A	RELEASED	J05-0186	S.O	3/29/05			0.XX ±0.3	MM		(CAT.NO.PHEC ___ P-S11_LF)		
B	REVISED	J07-0047	S.O	1/25/07			0.XXX ±0.3	MM		dwg no		
C	REVISED	J07-0458	S.O	9/11/07	0'±2'			scale N/A		sheet 1 of 1 size		
				dr	S.OKUDAIRA	3/29/05	FCI		JSC 96356		A3	
				enr	S.OKUDAIRA	9/11/07			Customer Drawing		Rev. C	
				chr	R. Showie	9/11/07						
				appd	D. Okudaira	9/11/07						
sheet index	revision sheet	C	1									