

XO7010 Series VCXO

Applications

SONET/SDH
Cellular Base Stations
Phase Locking
Data Communications



Features

High Frequency Fundamental
Wide Pulling Range
Standard 14 Pin DIP/DIL

Typical Specifications

Model	Frequency (MHz)	Temperature Range (°C)	Temperature Stability	Tuning	Output	Supply Voltage
XO7010	155.52	0 to +85	±20 ppm	±30 ppm	PECL	+5 V ±0.25 V
XO7011	155.52	0 to +85	±20 ppm	±30 ppm	ECL	-5.1V ±0.25V
Options	30- 200	Consult Factory		to ±75 ppm or no tuning	dual output pin 9 dual output pin 1	

Additional Specifications

Current 30 mA max
Electronic frequency control
Tuning voltage range 0 V to 5 V
Center frequency voltage 2.5 V ±0.5 V
Frequency tuning range ±30 to ±75 ppm
Transfer function Positive monotonic
Tune port modulation bandwidth 50 kHz min
Jitter 1.0 pSec max

Phase Noise @155 MHz	± 30	± 75
100 Hz	-95 dBc/Hz	-75 dBc/Hz
1 kHz	-120 dBc/Hz	-105 dBc/Hz
10 kHz	-140 dBc/Hz	-135 dBc/Hz
100 kHz	-140 dBc/Hz	-135 dBc/Hz
1 MHz	-140 dBc/Hz	-135 dBc/Hz
10 MHz	-140 dBc/Hz	-135 dBc/Hz

XO7010 Series

Dimensions are in inches (mm)

PIN CONNECTIONS

- FREQUENCY ADJUST OR RF OUTPUT
- CASE GROUND & SUPPLY RETURN
- RF OUTPUT
- RF OUTPUT (optional)
- SUPPLY (+)

Pin numbers shown for ref. only.
Numbers are not marked on unit.

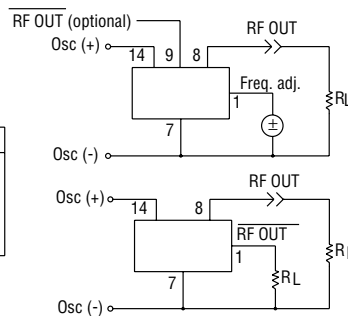

XO7011 Series

Dimensions are in inches (mm)

PIN CONNECTIONS

- FREQUENCY ADJUST OR RF OUTPUT
- SUPPLY (-)
- RF OUTPUT
- RF OUTPUT (optional)
- CASE GROUND & SUPPLY RETURN

Pin numbers shown for ref. only.
Numbers are not marked on unit.

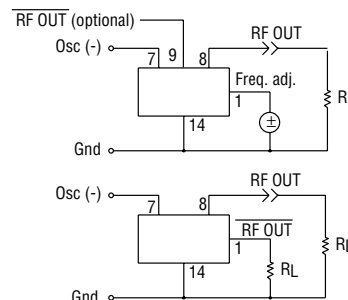

XO7010 & XO7011 Series

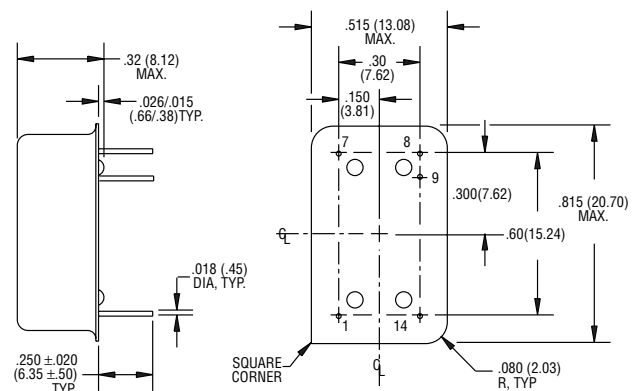

Specifications are subject to change without notice.

Visit our web site at <http://www.piezotech.com>

2525 Shader Road, Orlando, FL 32804 PH: (407) 298-2000 / FAX: (407) 293-2979

