



Part Number: **KLDR004.**

Technology: Fuses

Series: **KLDR**

KLDR Series - Class CC Time-Delay Fuse For Transformers

KLDR fuses are time-delay fuses specifically designed for the protection of control transformers, solenoids and similar inductive components with high magnetizing currents during the first half-cycle.

They closely match most control power transformer characteristics, which permits the fuses to be sized in accordance with the latest revisions of UL 508 (Industrial Control) and UL 845 (Motor Control Centers).

When the time delay of KLDR fuses is adequate to carry motor starting current, they provide excellent protection of motor branch circuits containing IEC or NEMA rated motor controllers or contractors.

Compared to other UL Listed fuses, Class CC fuses are the most current limiting, rating for rating. Because they are physically compact, they provide this superior protection in a fraction of the space required by other fuse classes.

For example, when 600V three-pole, 30 ampere Class R fuse blocks are replaced by Littelfuse Class CC fuse blocks, panel-mounting space is reduced approximately 70%. This is especially important when a panel contains many fuses to protect multiple circuit components.

Applications:

Three types of Class CC Fuses, specifically designed to protect different types of components:

1. Motor protection – CCMR series; dual-element, time-delay fuses specifically designed to protect motor circuits up to 40 HP. Review the motor protection tables in PF101 for more information.
2. Small transformer protection (control power transformers) – KLDR series, time-delay fuses designed to withstand the high magnetizing inrush of transformers.
3. General purpose protection of equipment requiring fast overload protection – KLKR series, fast-acting fuses used for protection of equipment containing solid-state devices or other electronic components requiring fast response on overloads.

Safety:

- 200,000 A.I.R. — Reliable interruption of all overcurrents up to 200,000 amperes.
- Extremely current limiting — Reduces damage caused by heating and magnetic effects of short-circuit currents... stops damaging short-circuit faster than any mechanical protective device.

Space Saving:

- Class CC fuses are the smallest 600V, 200,000 A.I.R. fuses approved for branch circuit protection.

Economical:

- Current limiting design often permits use of readily available, less costly equipment.

Electrical Characteristics

Property	Value
Amp Rating (A)	4
Form Factor	Class CC
Fuse Class	Supplemental
Opening Characteristic	Time Delay
Resistance (Ohms)	0.118000001
Voltage Rating (V)	600

Axial Lead and Cartridge Fuses

Midget

RoHS **Pb** **Class CC*** Fast-Acting & Slo-Blo® Type Fuses CCMR Series



Fast-acting KLKR fuses provide fast-acting protection to equipment containing surge sensitive components. Use KLKR fuses for non-inductive loads not requiring time delay. CCMR fuses (formerly KLMR) are specifically designed to withstand sustained starting currents of small motors. The CCMR fuses provide short-circuit protection for motor branch-circuits. KLDR fuses are specifically designed to withstand the momentary high magnetizing currents of control transformers, solenoids, and similar inductive loads.

ELECTRICAL CHARACTERISTICS:

% of Ampere Rating	Ampere Rating	Opening Time
110%	1/10–30	15 minutes, Minimum
135%	1/10–30	1 hour, Maximum

AGENCY APPROVALS: DC ratings are self-certified. KLKR Series: UL listed Fast-Acting Class CC per UL 248 and CSA Certified. KLDR, CCMR Series: UL listed Time-Delay Class CC per UL 248 and CSA Certified.

*CCMR 35-60A UL Listed Time-Delay Class CD.

INTERRUPTING RATING:

AC: 200,000 ampere

DC: 20,000 amperes

ORDERING INFORMATION:



ENVIRONMENTAL SPECS: only KLKR is RoHS compliant and lead-free

AGENCY FILE NUMBERS: UL E81895, CSA LR 29862.

VOLTAGE RATINGS: AC: 600 Volts
 DC: 250 Volts (CCMR 2/10 – 2A)
 (CCMR 4 1/2 – 10A)
 (CCMR 35 – 60A)
 300 Volts (CCMR 2 1/4 – 4A)
 300 Volts (KLDR)
 300 Volts (KLKR)

Ampere Rating	Catalog Number	Nominal Resistance Cold Ohms	Catalog Number	Nominal Resistance Cold Ohms	Catalog Number	Nominal Resistance Cold Ohms
1/10	—	—	KLDR.100	246	KLKR.100	79.33
1/8	—	—	KLDR.125	134.9	KLKR.125	56.52
15/100	—	—	KLDR.150	96	—	—
3/16	—	—	KLDR.187	66.4	—	—
2/10	CCMR.200	68.4	KLDR.200	57.8	KLKR.200	28.21
1/4	CCMR.250	43.3	KLDR.250	31.61	KLKR.250	19.22
3/10	CCMR.300	28.6	KLDR.300	25.5	KLKR.300	15.10
4/10	—	—	KLDR.400	13.6	—	—
1/2	CCMR.500	7.62	KLDR.500	15.9	KLKR.500	6.95
6/10	CCMR.600	8.2	KLDR.600	9.99	—	—
3/4	—	—	KLDR.750	6.08	KLKR.750	3.581
8/10	CCMR.800	4.013	KLDR.800	6.2	—	—
1	CCMR 001.	2.59	KLDR 001.	4.0	KLKR 001.	.2342
1 1/8	—	—	KLDR 1.12	2.94	—	—
1 1/4	CCMR 1.25	1.687	KLDR 1.25	2.33	—	—
1 4/10	CCMR 01.4	1.33	KLDR 01.4	1.5	—	—
1 1/2	CCMR 01.5	1.24	KLDR 01.5	.898	KLKR 01.5	.225
1 6/10	CCMR 01.6	.9894	KLDR 01.6	.625	—	—
1 8/10	CCMR 01.8	.7783	KLDR 01.8	.486	—	—
2	CCMR 002.	.485	KLDR 002.	.55	KLKR 002.	.135
2 1/4	CCMR 2.25	.4166	KLDR 2.25	.52	—	—
2 1/2	CCMR 02.5	.3375	KLDR 02.5	.333	KLKR 02.5	.0906
2 8/10	CCMR 02.8	.2400	KLDR 02.8	.26	—	—
3	CCMR 003.	.2188	KLDR 003.	.21	KLKR 003.	.0776
3 2/10	CCMR 03.2	.1855	KLDR 03.2	.171	—	—
3 1/2	CCMR 03.5	.1346	KLDR 03.5	.239	KLKR 03.5	.0562
4	CCMR 004.	.1231	KLDR 004.	.118	KLKR 004.	.0468
4 1/2	CCMR 04.5	.093	KLDR 04.5	.082	—	—
5	CCMR 005.	.0704	KLDR 005.	.0399	KLKR 005.	.0332
5 6/10	CCMR 05.6	.0535	KLDR 05.6	.0334	—	—
6	CCMR 006.	.0517	KLDR 006.	.0315	KLKR 006.	.0238
6 1/4	CCMR 6.25	.0464	KLDR 6.25	.03	—	—
7	CCMR 007.	.0369	KLDR 007.	.0253	KLKR 007.	.0208
7 1/2	CCMR 07.5	.027	KLDR 07.5	.0205	—	—
8	CCMR 008.	.023	KLDR 008.	.0193	KLKR 008.	.0177
9	CCMR 009.	.0193	KLDR 009.	.0155	KLKR 009.	.0151
10	CCMR 010.	.0133	KLDR 010.	.0122	KLKR 010.	.01325
12	CCMR 012.	.0114	KLDR 012.	.0114	KLKR 012.	.00852
15	CCMR 015.	.00708	KLDR 015.	.00708	KLKR 015.	.0074
17 1/2	CCMR 17.5	.00495	KLDR 17.5	.00495	—	—
20	CCMR 020.	.00360	KLDR 020.	.0036	KLKR 020.	.00511
25	CCMR 025.	.00250	KLDR 025.	.0025	KLKR 025.	.003775
30	CCMR 030.	.00240	KLDR 030.	.0024	KLKR 030.	.002954
35	CCMR 035.	.00426	—	—	—	—
40	CCMR 040.	.00286	—	—	—	—
45	CCMR 045.	.00246	—	—	—	—
50	CCMR 050.	.00182	—	—	—	—
60	CCMR 060.	.00118	—	—	—	—

11 AXIAL LEAD AND CARTRIDGE FUSES

11 AXIAL LEAD AND CARTRIDGE FUSES

Axial Lead and Cartridge Fuses

RoHS **Pb** **Class CC*** Fast-Acting & Slo-Blo® Type Fuses CCMR Series

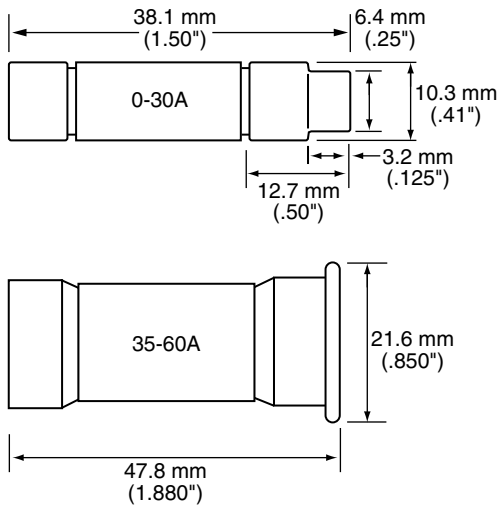

Average Time Current Curve (CCMR)

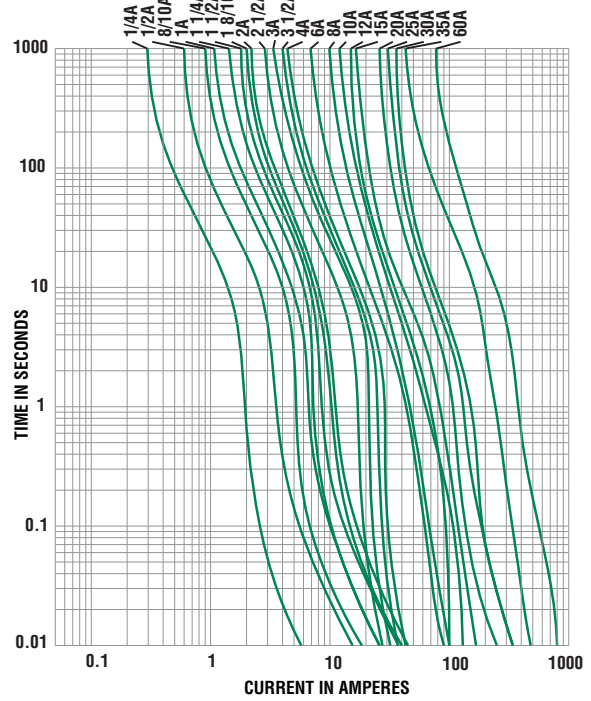

Average Time Current Curve (KLDR)

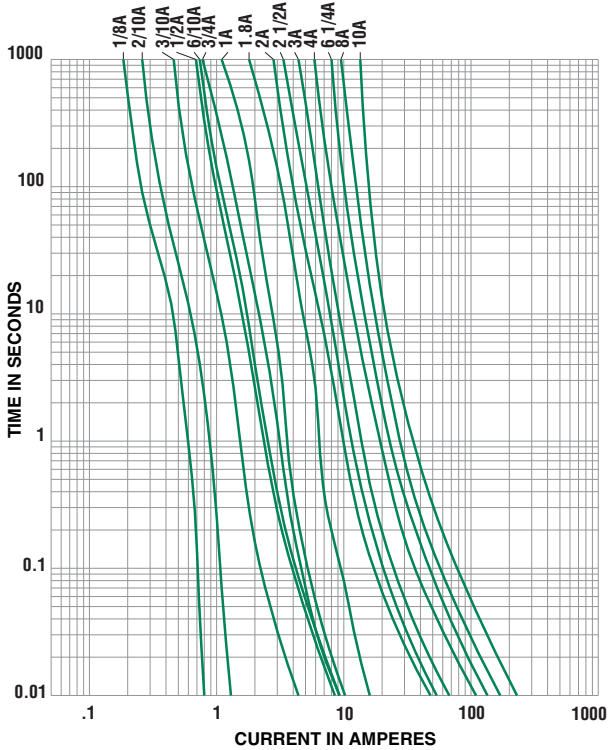

Average Time Current Curve (KLKR)

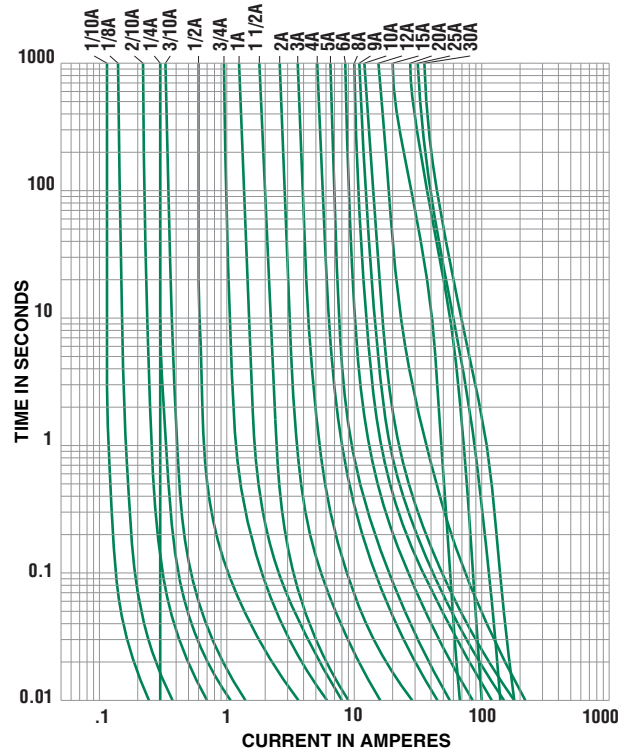

AXIAL LEAD AND
CARTRIDGE FUSES