

| DASH NO. | DESCRIPTION | MADE FROM |
|----------|-------------|-----------|
|----------|-------------|-----------|

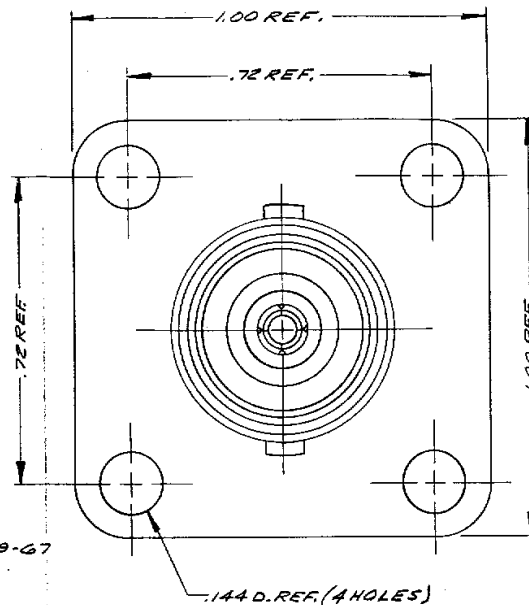
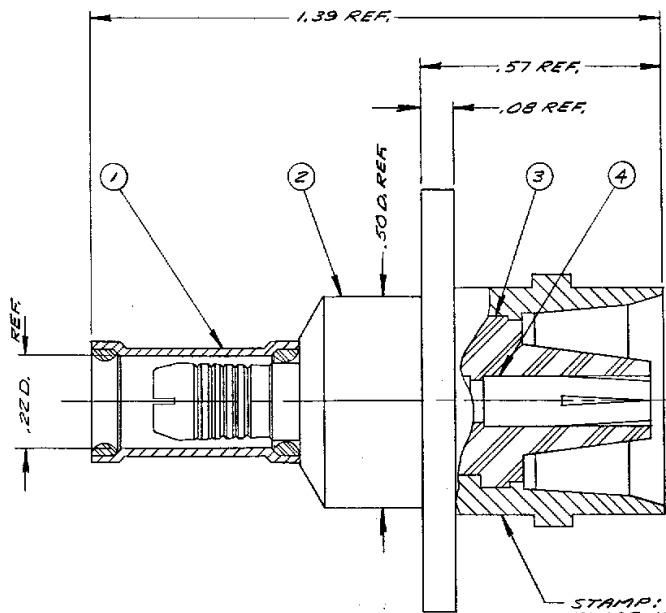

STAMP:
KINGS KD-19-67

- NOTES:
 1. FOR USE WITH RG-142 B223 600/U CABLE
 2. FOR CABLE TRIMMING USE KTJ-160 & KTD 208.
 3. FOR FORMING USE CRIMP DIE SIZE 101.
 4. FOR CABLING INSTRUCTIONS SEE CP-5406.
 5. ITEMS ① & ② TO HAVE TR-5 FINISH.

UNLESS OTHERWISE SPECIFIED:

- | | |
|--|--|
| 1. TOLERANCES: FRACTIONS & 2 PLACE DECIMALS ± .010 | 2. REMOVE ALL BURRS. BREAK SHARP EDGES .005 MAX. |
| 3 PLACE DECIMALS ± .004 | 3. NO FILLETS PERMITTED. |
| T. I. R. CONCENTRICITY OF ANY 2 DIAMETERS MAY NOT EXCEED HALF THE SUM OF THEIR TOLERANCES. | 4. SURFACE ROUGHNESS 63 MICROINCHES RMS MAX. |
| | 5. ALL DIMENSIONS PRIOR TO PLATING. |

| 4 | 1 | CAPTIVE CRIMP CONTACT F | 1-842-BMA9 |
|------|-------|-------------------------|-----------------|
| 3 | 1 | INSULATOR | |
| 2 | 1 | K-GRIP BODY | |
| 1 | 1 | W/P K-GRIP SLEEVE | C-59-21B-2-1106 |
| ITEM | REQ'D | DESCRIPTION | PART NO. |

KD-19-67

| REVISIONS | |
|-----------|--|
| ISSUE | CHANGES |
| 0 | ER 14986 MJB 19 NOV 75 |
| 1. | CN 15689A JHP 23 APR 76 |
| 2. | CN 16182 E GG 99UG 76 RG-223 ADDED |
| 3 | CN 26163 C EAJ 24 MAY 84 |
| 4 | CN 29130 C AMD 17 AUG 84 |

USED ON:

REF:

FINISH:

SPEC:

MATL:

SPEC:

C PANEL JACK

DRAWN MJB DATE 21 NOV 75

APPR: [Signature] DATE 21 NOV 75

KINGS ELECTRONICS
40 MARLBOROUGH ROAD
TUCKAHOE, N. Y. 10707

KD-19-67

S-D