



**Anti-Sulfurated Thick Film Chip  
Resistor Arrays  
( CNCS34 Concave Type )  
Halogen-Free**

Document No	TCNCS-340S001F
Revised Date	2014/08/05
page number	1 / 8

**1. Scope :**

This specification applies for the CNCS34 Concave Type of Anti-Sulfurated thick film chip resistor arrays made by TA-I.

**2. Construction , Dimensions , Schematic :**

**2.1 Construction :**

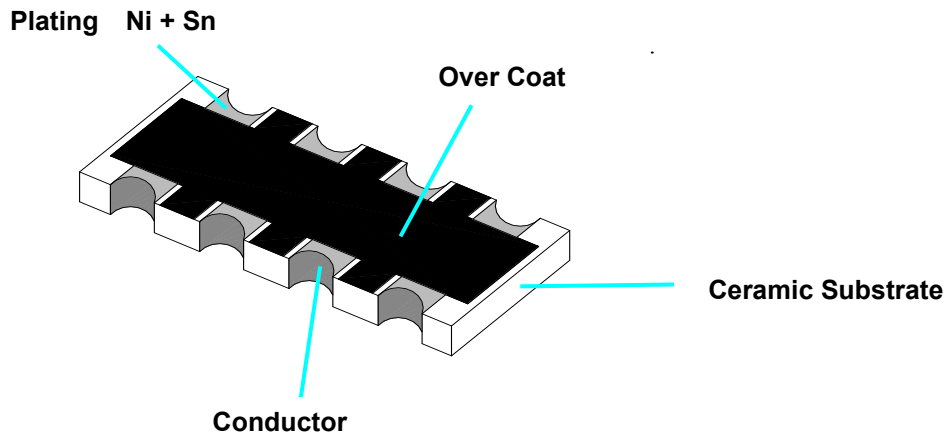

**2.1.1 Chip Resistor Arrays :**

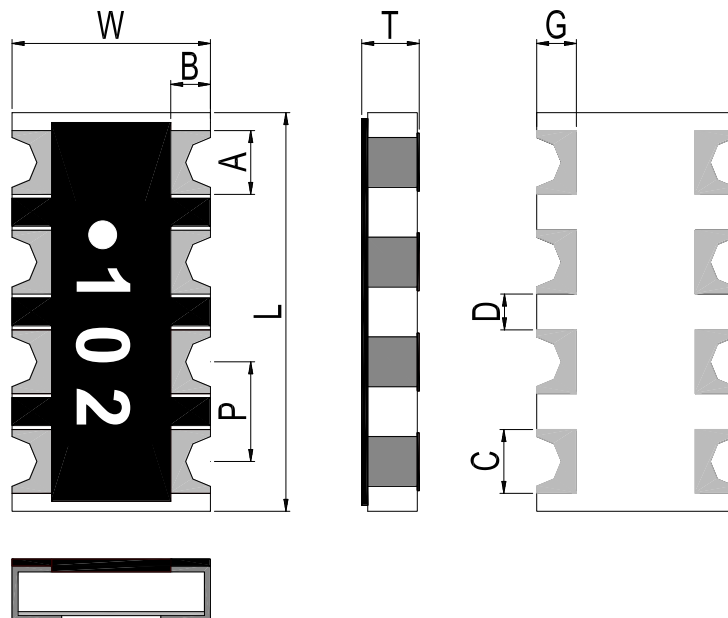

**2.2 Dimension :**

UNIT:mm

Type	L	W	T	P	A	B	C	D	G
CNCS34	3.2±0.2	1.5±0.2	0.55±0.1	0.8±0.1	0.6±0.1	0.3±0.2	0.5±0.1	0.25±0.1	0.35±0.15



**Anti-Sulfurated Thick Film Chip  
Resistor Arrays  
( CNCS34 Concave Type )  
Halogen-Free**

Document No	TCNCS-340S001F
Revised Date	2014/08/05
page number	2 / 8

**2.3 Schematic :**

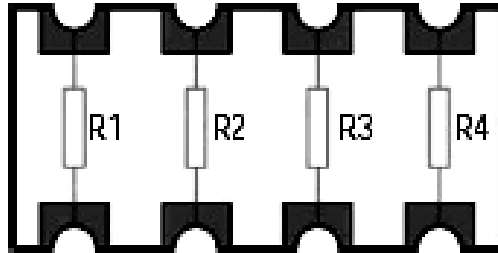

$R1 = R2 = R3 = R4$

**3. Type Designation :**

**3.1 Chip Resistor Arrays :**

**CNCS                      34                      J                      T                      102**

<b>Product Code</b>	<b>size</b>	<b>Tolerance</b>	<b>Packaging</b>	<b>Nominal Resistance</b>
CNC: Anti-Sulfurated Chip Resistor Arrays Concave type	Power Rating			

34 - 0603 *4	J-±5% F-±1%	T- Paper Tape	3 digits e.g.,: (E-24) 102 = 1KΩ
--------------	----------------	---------------	-------------------------------------

**4. Ratings & Characteristics :**

Type	Power Rating at 70°C	Rating Voltage	Max .Working Voltage	Max. OverLoad Voltage	Operating Temp.(°C)	Resistance Tolerance(%)	Resistance Range (Ω)	Temp Coefficient PPM/°C
CNCS34	1/16W	Refer 4.2	50V	100V	-55   +125°C	±5%	10Ω~1MΩ	±200



Anti-Sulfurated Thick Film Chip  
Resistor Arrays  
( CNCS34 Concave Type )  
Halogen-Free

Document No	TCNCS-340S001F
Revised Date	2014/08/05
page number	3 / 8

#### 4.1 Derating Curve :

For resistors operated at ambient temperature over 70°C , power rating shall be derated in accordance with figure 1.

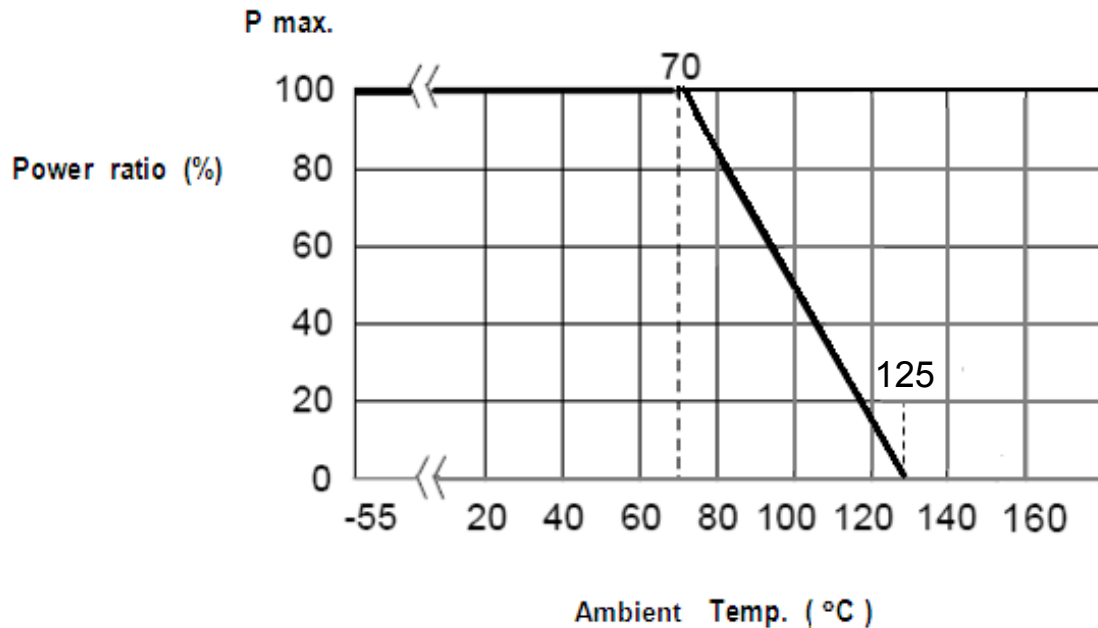

Figure 1

#### 4.2 Rated Voltage :

The rated voltage is calculated by the following formula:

$$E = \sqrt{P * R}$$

E=Rated Voltage(V)  
 P=Rated Power(W)  
 R=Resistance Value( $\Omega$ )

E.G. : What is CNCS34JT102 the rated voltage ?  
 CNCS34JT102 P:1/16W ; R:102 = 1K $\Omega$  = 1000 $\Omega$

$$E = \sqrt{0.0625(W) * 1000(\Omega)} = 7.9 (V)$$



**Anti-Sulfurated Thick Film Chip  
Resistor Arrays  
( CNCS34 Concave Type )  
Halogen-Free**

Document No	TCNCS-340S001F
Revised Date	2014/08/05
page number	4 / 8

**5. Reliability Tests :**

Test Items	Reference standard	Condition of Test	Test Limits ( $\Delta R/R$ )
Temperature Coefficient of Resistance	IEC60115-1-4.8 JIS-C5201-1-4.8	-55~ +125 °C	Refer 4.0
Short Time Overload	IEC60115-1-4.13 JIS-C5201-1-4.13	2.5 X rated voltage for 5 sec	$\pm ( 2.0 \% + 0.1\Omega )$
Intermittent Overload	IEC60115-1-4.39 JIS-C5201-1-4.39	2.5X rated voltage or Max Overloading Voltage , 1sec "ON" 25 sec "OFF" , 10000 cycles	$\pm ( 5.0\% + 0.1\Omega )$
Load Life	IEC60115-1-4.25.1 JIS-C5201-1-4.25.1	1000 hours at rated voltage , 70°C , 1.5hours "ON " , 0.5hour "OFF"	1%: $\pm(1.0\%+0.05\Omega)$ 5%: $\pm(3.0\%+0.1\Omega)$
Load Life with Humidity	IEC60115-1-4.24 JIS-C5201-1-4.24	1000 hours at rated voltage , 40 $\pm$ 2°C, 90~95% RH 1.5hours "ON " , 0.5hour "OFF"	1%: $\pm(1.0\%+0.05\Omega)$ 5%: $\pm(3.0\%+0.1\Omega)$
Rapid Change of Temperature	IEC60115-1-4.19 JIS-C5201-1-4.19	-55°C (30 min. ) / +125 °C (30 min. ) 5 cycles	1%: $\pm(0.5\%+0.05\Omega)$ 5%: $\pm(1.0\%+0.05\Omega)$
Solderability	IEC60115-1-4.17 JIS-C5201-1-4.17	245 $\pm$ 5°C solder, 2 $\pm$ 0.5 sec dwell. Solder : Sn96.5 / Ag3.0 / Cu0.5	At least 95% of surface area of electrode shall be covered with new solder.
Core body	IEC60115-1-4.15 JIS-C5201-1-4.15	Pressure 1.0 kgf a R0.5 pressure rod for 10 sec	Without mechanical damage such as breaks. Electrical characteristics shall be satisfied
Dielectric Withstanding Voltage (Voltage Proof)	IEC60115-1-4.7 JIS-C5201-1-4.7	Applying voltage 100V for 1 minute	No abnormalities such as flashover, burning dielectric breakdown shall appear.
Resistance to Solder Heat	IEC60115-1-4.18 JIS-C5201-1-4.18	260 $\pm$ 5°C solder , 10 $\pm$ 1 sec dwell .	1%: $\pm(1.0\%+0.05\Omega)$ 5%: $\pm ( 2.0\% + 0.1\Omega )$
Sulfuration Test	ASTM-B-809-95	Sulfur(saturated vapor) 1,000 hours,105 $\pm$ 2°C, unpowered	$\pm(2\%+0.05\Omega)$

Note\* : RCWW : Rated continuous working voltage .



**Anti-Sulfurated Thick Film Chip  
Resistor Arrays  
( CNCS34 Concave Type )  
Halogen-Free**

Document No	TCNCS-340S001F
Revised Date	2014/08/05
page number	5 / 8

**6. Marking :**

**6.1 ±5%(E24)**

Resistance value is expressed by 3 digits, the first two digits represent the significant figures of nominal resistance value in  $\Omega$ , and the third digit represents exponent for base of 10.

E.G.  $472 = 47 \times 10^2 = 4700 \Omega = 4.7K \Omega$

**6.2 ±1%(E96)**

Resistance value is expressed by 4 digits, the first three digits represent the significant figures of nominal resistance value in  $\Omega$ , and the fourth digit represents exponent for base of 10.

E.G. :  $1000 = 100 \times 10^0 = 100 \Omega$

**7. Taping & Reel :**

**7.1 Taping Dimensions :**

**7.1.1 4 mm pitch paper :**

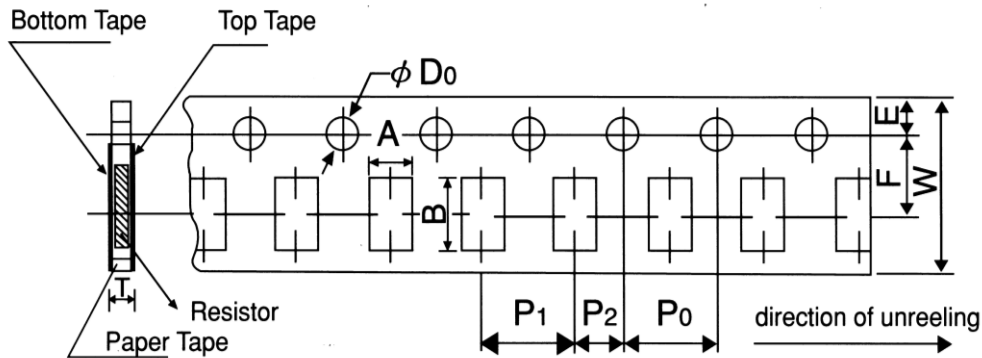

UNIT: mm

Type	A	B	W	F	E	P1	P2	P0	$\phi D0$	T0
CNCS34	2.0±0.15	3.6±0.2	8.0±0.2	3.5±0.05	1.75±0.1	4.0±0.1	2.0±0.05	4.0±0.1	+0.1 -0	0.84±0.1

Package Type	Paper Tape
	4 mm pitch
	178mm/R
CNCS34	5000



**Anti-Sulfurated Thick Film Chip  
Resistor Arrays  
( CNCS34 Concave Type )  
Halogen-Free**

Document No	TCNCS-340S001F
Revised Date	2014/08/05
page number	6 / 8

**7.2 Reel Specifications :**

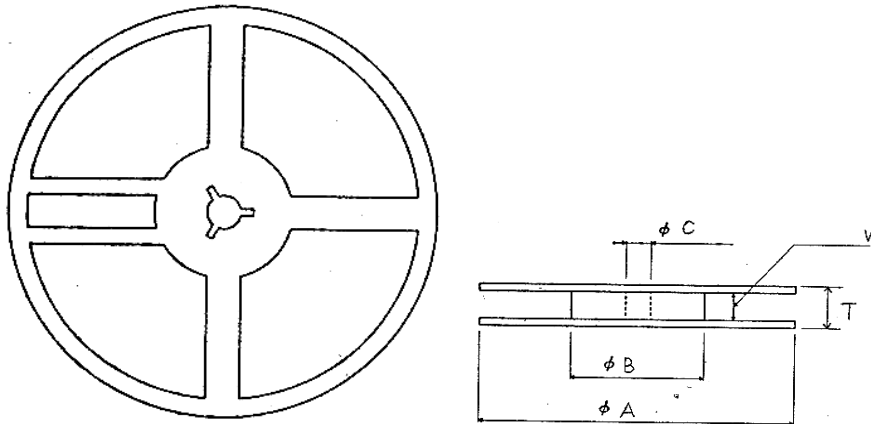

**UNIT: mm**

Type	$\phi A$	$\phi B$	$\phi C$	W	T
CNCS34	$178.0 \pm 2.0$	60 or more	$13.0 \pm 1.0$	$9.0 \pm 1.0$	$11.5 \pm 1.0$

**7.3 Peel off Strength :**

Peel –off force of paper and blister tape is in accordance with “JIS-C5202”  
that is , 0.1 to 0.7 N at a peel-off speed of 300 mm / minute.

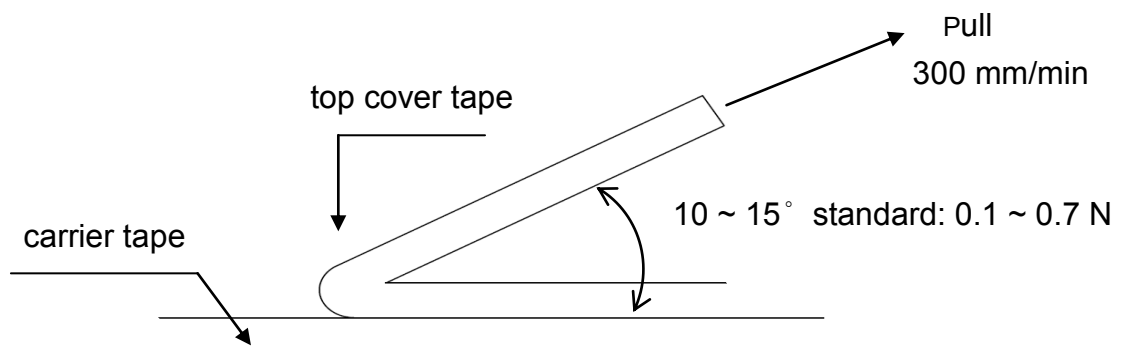



**Anti-Sulfurated Thick Film Chip  
Resistor Arrays  
( CNCS34 Concave Type )  
Halogen-Free**

Document No	TCNCS-340S001F
Revised Date	2014/08/05
page number	7 / 8

**8. Label :**

**8.1 Manufacture Label :**

**8.1.1 Chip Resistor Array**

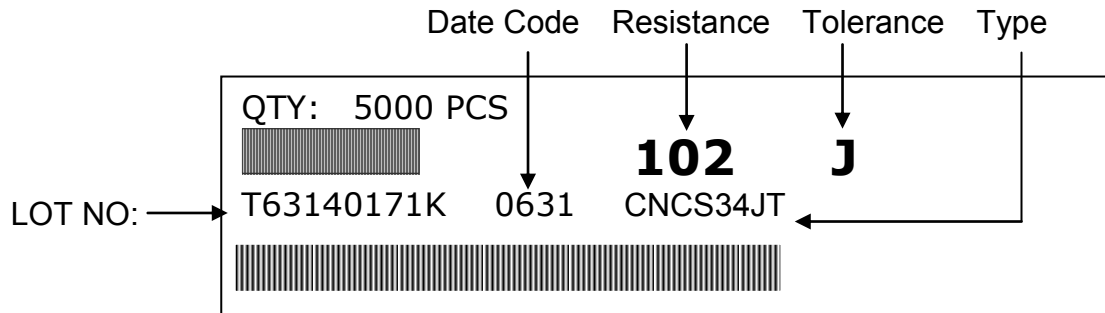

**8.2. Customer Label ( By customer request ) :**

**8.2.1 Chip Resistor Array**

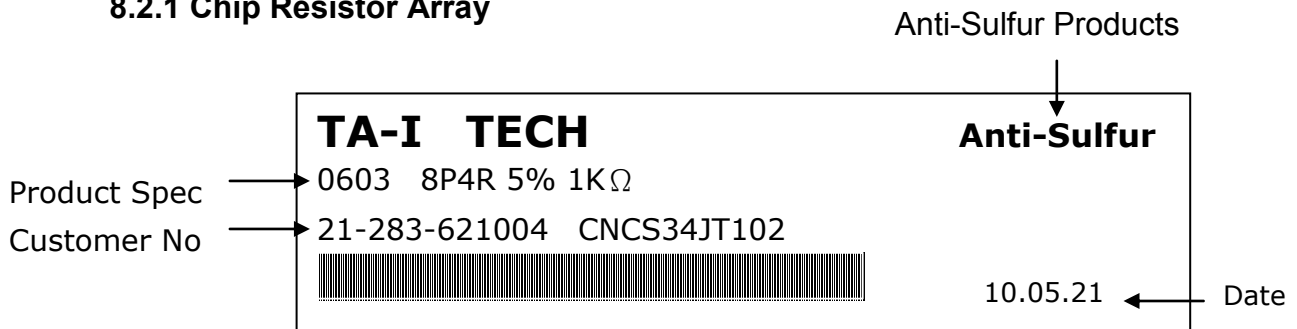

**9. Recommended land patterns :**

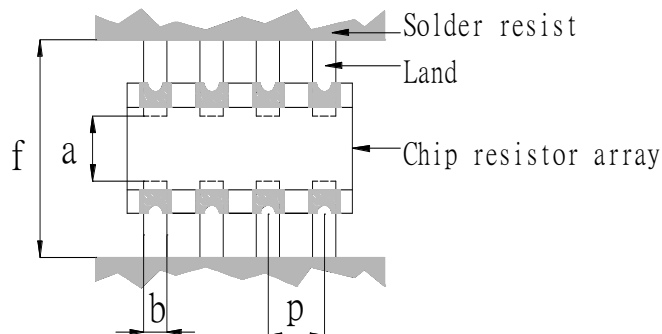

Land pattern		Dimension ( mm )			
Type	Size	a	b	p	f
CNCS	34	0.7~0.9	0.40~0.45	0.8	2.2~2.6



Anti-Sulfurated Thick Film Chip  
Resistor Arrays  
( CNCS34 Concave Type )  
Halogen-Free

Document No	TCNCS-340S001F
Revised Date	2014/08/05
page number	8 / 8

**10. Recommend IR – Reflow profile : (solder : Sn96.5 / Ag3 / Cu0.5) :**

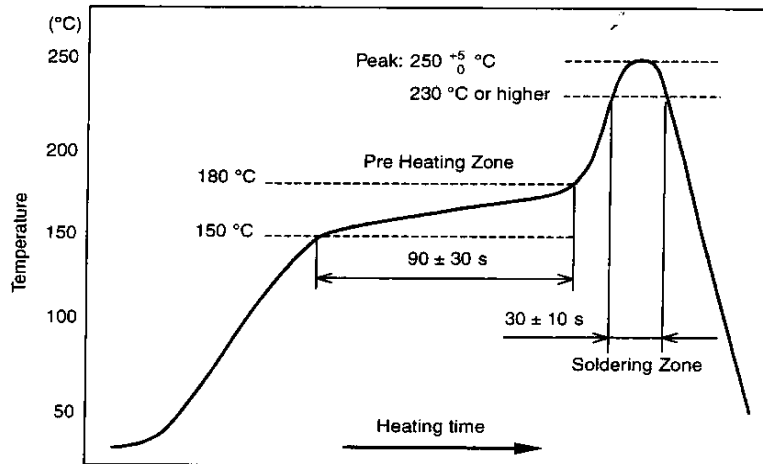

Peak :  $250 \begin{matrix} +5 \\ -0 \end{matrix} \text{ } ^\circ\text{C}$  , 5 sec

Pre – heat Zone : 150 to 180  $^\circ\text{C}$  , 90  $\pm$  30 sec  
Soldering Zone : 230 $^\circ\text{C}$  or higher , 30  $\pm$  10 sec

**11. Storage Conditions :**

Temperature : 5 to 35  $^\circ\text{C}$   
Related Humidity :40 to 75% RH

**12. Shelf Life :**

2 Years from manufacturing date.

**13. ECN :**

Engineering Change Notice: The customer will be informed with ECN if there is significant modification on the characteristics and materials described in Approval Sheet.

**14. Manufacturing Country & City :**

TA-I TECHNOLOGY CO., LTD. ( Taiwan – Tao Yuan )  
Tel: 886-3-3246169 Fax : 886-3-3246167

Associated companies :

- (1) FORTUNE TASK RESISTOR FACTORY ( China – Dongguan )  
Tel : 86-769-8339-4790~3 Fax : 86-769-8339-4794
- (2) TA-I TECHNOLOGY (DONGGUAN ) CO., LTD. ( China –Dongguan )  
Tel : 86-769-8339-4790~3 Fax : 86-769-8339-4794
- (3) TA-I TECHNOLOGY ( SU ZHOU ) CO., LTD. ( China – Su Zhou)  
Tel :86- 512-63457879 Fax : 86-512-63457869
- (4) TAI OHM ELECTRONICS ( M ) SDN. BHD. ( Malaysia – Pulaupinang )  
Tel :604- 3900480 Fax : 604-3901481
- (5) P.T.TAI ELECTRONICS Indonesia ( Indonesia – Jakarta )  
Tel :62-21-89830123 Fax : 62-21-89830703