

### FEATURES

#### Programmable capacitance-to-digital converter

36 ms update rate (@ maximum sequence length)

Better than 1 fF resolution

14 capacitance sensor input channels

No external RC tuning components required

Automatic conversion sequencer

#### On-chip automatic calibration logic

Automatic compensation for environmental changes

Automatic adaptive threshold and sensitivity levels

#### On-chip RAM to store calibration data

SPI<sup>®</sup>-compatible serial interface (AD7142)

I<sup>2</sup>C<sup>®</sup>-compatible serial interface (AD7142-1)

Separate V<sub>DRIVE</sub> level for serial interface

Interrupt output and GPIO

32-lead, 5 mm x 5 mm LFCSP\_VQ

2.6 V to 3.6 V supply voltage

Low operating current

Full power mode: less than 1 mA

Low power mode: 50 μA

### APPLICATIONS

Personal music and multimedia players

Cell phones

Digital still cameras

Smart hand-held devices

Television, A/V, and remote controls

Gaming consoles

### GENERAL DESCRIPTION

The AD7142 and AD7142-1 are integrated capacitance-to-digital converters (CDCs) with on-chip environmental calibration for use in systems requiring a novel user input method. The AD7142 and AD7142-1 can interface to external capacitance sensors implementing functions such as capacitive buttons, scroll bars, or wheels.

The CDC has 14 inputs channeled through a switch matrix to a 16-bit, 250 kHz sigma-delta ( $\Sigma$ - $\Delta$ ) capacitance-to-digital converter. The CDC is capable of sensing changes in the capacitance of the external sensors and uses this information to register a sensor activation. The external sensors can be arranged as a series of buttons, as a scroll bar or wheel, or as a combination of sensor types. By programming the registers, the user has full control over the CDC setup. High resolution sensors require minor software to run on the host processor.

#### Rev. A

Information furnished by Analog Devices is believed to be accurate and reliable. However, no responsibility is assumed by Analog Devices for its use, nor for any infringements of patents or other rights of third parties that may result from its use. Specifications subject to change without notice. No license is granted by implication or otherwise under any patent or patent rights of Analog Devices. Trademarks and registered trademarks are the property of their respective owners.

### FUNCTIONAL BLOCK DIAGRAM

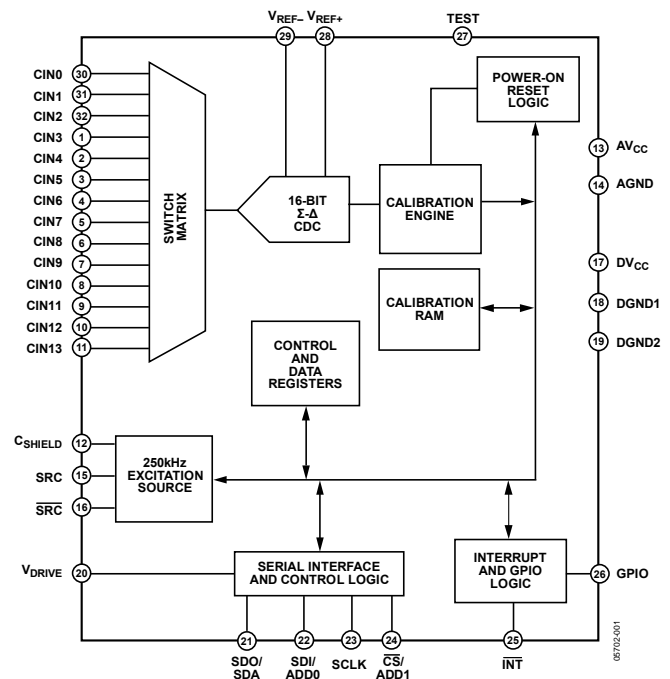

Figure 1.

The AD7142 and AD7142-1 have on-chip calibration logic to account for changes in the ambient environment. The calibration sequence is performed automatically and at continuous intervals, when the sensors are not touched. This ensures that there are no false or nonregistering touches on the external sensors due to a changing environment.

The AD7142 has an SPI-compatible serial interface, and the AD7142-1 has an I<sup>2</sup>C-compatible serial interface. Both parts have an interrupt output, as well as a general-purpose input/output (GPIO).

The AD7142 and AD7142-1 are available in a 32-lead, 5 mm × 5 mm LFCSP\_VQ and operate from a 2.6 V to 3.6 V supply. The operating current consumption is less than 1 mA, falling to 50 μA in low power mode (conversion interval of 400 ms).

# IMPORTANT LINKS for the [AD7142](#)\*

Last content update 06/27/2013 05:41 am

This product is not recommended for new designs. The [AD7147](#) is recommended instead for new CapTouch<sup>(R)</sup> designs.

## PARAMETRIC SELECTION TABLES

[Find Similar Products By Operating Parameters](#)

## DOCUMENTATION

**AN-854:** Sensor PCB Design Guidelines for the AD7142 and AD7143 Capacitance-to-Digital Converters

**AN-929:** Tuning the AD714x for CapTouch<sup>(R)</sup> Applications

**AN-857:** Introduction to AD7142 Host Software Requirements

**AN-858:** AD7142 Sensor Board In-Line Production Test Procedure

**AN-830:** Factors Affecting Sensor Response

**AN-829:** Environmental Compensation on the AD7142: The Effects of Temperature and Humidity on Capacitance Sensors

Webcast: Design And Develop Innovative And Robust Touch Sensor Interfaces Using Capacitive-To-Digital Converters

Capacitance Sensors for Human Interfaces to Electronic Equipment

**MS-2210:** Designing Power Supplies for High Speed ADC

Capacitive Sensors Can Replace Mechanical Switches for Touch Control

Programmable Medical Infusion Pumps Offer High Reliability and Performance

Building a reliable capacitive-sensor interface

EE Times Names ACE Finalists

Programmable 16-Bit CDC Targets Handheld Touch Screen Apps

Programmable Capacitance-to-Digital Converter Includes 14 Channels

Capacitance-To-Digital Converter Eases Touch-Based Switch Implementation

Capacitance-To-Digital Converter Simplifies Touchpad Design

ADI's Capacitance-To-Digital Converter

analogZONE Reviews The AD7142 CDC

Capacitive Touch Sensors Gain Fans

iPod's Lesson: Please Touch

Capacitive Touch Sensors Fulfill Early Promise

Motion Sensing Devices Make Integrated Systems Easy

Visit the **AD7142 Product Page** for more documentation.

## DESIGN TOOLS, MODELS, DRIVERS & SOFTWARE

[AD714X Input CapTouch<sup>\(R\)</sup> Programmable Controller Linux Driver](#)

## EVALUATION KITS & SYMBOLS & FOOTPRINTS

[Symbols and Footprints](#)

## DESIGN COLLABORATION COMMUNITY



[Collaborate Online](#) with the ADI support team and other designers about select ADI products.

Follow us on Twitter: [www.twitter.com/ADI\\_News](http://www.twitter.com/ADI_News)

Like us on Facebook: [www.facebook.com/AnalogDevicesInc](http://www.facebook.com/AnalogDevicesInc)

## DESIGN SUPPORT

Submit your support request here:

[Linear and Data Converters](#)

[Embedded Processing and DSP](#)

Telephone our Customer Interaction Centers toll free:

Americas: 1-800-262-5643  
Europe: 00800-266-822-82  
China: 4006-100-006  
India: 1800-419-0108  
Russia: 8-800-555-45-90

[Quality and Reliability](#)

[Lead\(Pb\)-Free Data](#)

## SAMPLE & BUY

### AD7142

- View Price & Packaging
- Request Evaluation Board
- Request Samples Check Inventory & Purchase

[Find Local Distributors](#)

\* This page was dynamically generated by Analog Devices, Inc. and inserted into this data sheet.

Note: Dynamic changes to the content on this page (labeled 'Important Links') does not constitute a change to the revision number of the product data sheet.

This content may be frequently modified.

## TABLE OF CONTENTS

Features .....	1	Capacitance Sensor Behavior with Calibration.....	22
Applications.....	1	SLOW FIFO .....	23
Functional Block Diagram .....	1	SLOW_FILTER_UPDATE_LVL.....	23
General Description .....	1	Adaptive Threshold and Sensitivity .....	24
Revision History .....	3	Interrupt Output.....	26
Specifications.....	4	CDC Conversion Complete Interrupt.....	26
SPI Timing Specifications (AD7142).....	6	Sensor Touch Interrupt.....	26
I <sup>2</sup> C Timing Specifications (AD7142-1) .....	7	GPIO $\overline{\text{INT}}$ Output Control .....	28
Absolute Maximum Ratings.....	8	Outputs .....	30
ESD Caution.....	8	Excitation Source.....	30
Pin Configurations and Function Descriptions .....	9	C <sub>SHIELD</sub> Output .....	30
Typical Performance Characteristics .....	10	GPIO .....	30
Theory of Operation .....	12	Using the GPIO to turn on/off an LED .....	30
Capacitance Sensing Theory.....	12	Serial Interface .....	31
Operating Modes.....	13	SPI Interface .....	31
Capacitance Sensor Input Configuration.....	14	I <sup>2</sup> C Compatible Interface.....	33
CIN Input Multiplexer Setup .....	14	V <sub>DRIVE</sub> Input .....	35
Capacitance-to-Digital Converter .....	15	PCB Design Guidelines .....	36
Oversampling the CDC Output .....	15	Capacitive Sensor Board Mechanical Specifications .....	36
Capacitance Sensor Offset Control.....	15	Chip Scale Packages .....	36
Conversion Sequencer .....	15	Power-Up Sequence .....	37
CDC Conversion Sequence Time .....	16	Typical Application Circuits .....	38
CDC Conversion Results.....	17	Register Map .....	39
Noncontact Proximity Detection .....	18	Detailed Register Descriptions .....	40
Recalibration .....	18	Bank 1 Registers .....	40
Proximity Sensitivity .....	18	Bank 2 Registers .....	50
FF_SKIP_CNT.....	20	Bank 3 Registers .....	57
Environmental Calibration .....	22	Outline Dimensions .....	69
Capacitance Sensor Behavior Without Calibration .....	22	Ordering Guide .....	69

**REVISION HISTORY****1/07—Rev. 0 to Rev. A**

Updated Format.....	Universal
Changes to Data Sheet Title.....	1
Inserted Figure 5.....	8
Changes to Figure 18.....	12
Changes to Operating Modes Section.....	13
Changes to CIN Input Multiplexer Setup Section.....	14
Changes to Table 9 and Conversion Sequencer Section.....	15
Changes to Noncontact Proximity Detection Section.....	18
Changes to Recalibration Section and Table 12.....	18
Deleted FIFO Control Section.....	19
Changes to Figure 31 and Table 13.....	20
Changes to Figure 32.....	21
Changes to Capacitance Sensor Behavior with Calibration Section.....	22

Added Slow FIFO and SLOW_FILTER_UPDATE_LVL Section.....	23
Changes to Adaptive Threshold and Sensitivity Section.....	24
Inserted Figure 37 and Table 13.....	25
Deleted Figure 42.....	29
Changes to C <sub>SHIELD</sub> Output Section.....	30
Changes to Figure 55.....	36
Changes to Power-up Sequence Section.....	37
Changes to Figure 58.....	38
Changes to Table 21.....	42
Changes to Table 24.....	43
Changes to Table 25.....	44
Changes to Table 29.....	48
Changes to Table 31.....	49

**6/06—Revision 0: Initial Version**

## SPECIFICATIONS

$AV_{CC}$ ,  $DV_{CC}$  = 2.6 V to 3.6 V,  $T_A$  =  $-40^{\circ}\text{C}$  to  $+85^{\circ}\text{C}$ , unless otherwise noted.

Table 1.

Parameter	Min	Typ	Max	Unit	Test Conditions/Comments
<b>CAPACITANCE-TO-DIGITAL CONVERTER</b>					
Update Rate	35.45	36.86	38.4	ms	12 conversion stages in sequencer, decimation rate = 256
Resolution		16		Bit	
CIN Input Range <sup>1</sup>		$\pm 2$		pF	
No Missing Codes	16			Bit	Guaranteed by design, but not production tested
CIN Input Leakage		25		nA	
Total Unadjusted Error			$\pm 20$	%	
Output Noise (Peak-to-Peak)		7		Codes	Decimation rate = 128
		3		Codes	Decimation rate = 256
Output Noise (RMS)		0.8		Codes	Decimation rate = 128
		0.5		Codes	Decimation rate = 256
Parasitic Capacitance			40	pF	Parasitic capacitance to ground, per CIN input guaranteed by characterization
$C_{BULK}$ Offset Range <sup>1</sup>		$\pm 20$		pF	
$C_{BULK}$ Offset Resolution		156.25		fF	
Low Power Mode Delay Accuracy			4	%	% of 200 ms, 400 ms, 600 ms, or 800 ms
<b>EXCITATION SOURCE</b>					
Frequency	240	250	260	kHz	
Output Voltage			$AV_{CC}$	V	
Short-Circuit Source Current		20		mA	
Short-Circuit Sink Current		50		mA	
Maximum Output Load		250		pF	Capacitance load on source to ground
$C_{SHIELD}$ Output Drive		10		$\mu\text{A}$	
$C_{SHIELD}$ Bias Level		$AV_{CC}/2$		V	
<b>LOGIC INPUTS (SDI, SCLK, <math>\overline{\text{CS}}</math>, SDA, GPI TEST)</b>					
$V_{IH}$ Input High Voltage	$0.7 \times V_{DRIVE}$			V	
$V_{IL}$ Input Low Voltage			0.4	V	
$I_{IH}$ Input High Voltage	-1			$\mu\text{A}$	$V_{IN} = V_{DRIVE}$
$I_{IL}$ Input Low Voltage			1	$\mu\text{A}$	$V_{IN} = \text{DGND}$
Hysteresis		150		mV	
<b>OPEN-DRAIN OUTPUTS (SCLK, SDA, <math>\overline{\text{INT}}</math>)</b>					
$V_{OL}$ Output Low Voltage			0.4	V	$I_{SINK} = -1 \text{ mA}$
$I_{OH}$ Output High Leakage Current		0.1	$\pm 1$	$\mu\text{A}$	$V_{OUT} = V_{DRIVE}$
<b>LOGIC OUTPUTS (SDO, GPO)</b>					
$V_{OL}$ Output Low Voltage			0.4	V	$I_{SINK} = 1 \text{ mA}$ , $V_{DRIVE} = 1.65 \text{ V to } 3.6 \text{ V}$
$V_{OH}$ Output High Voltage	$V_{DRIVE} - 0.6$			V	$I_{SOURCE} = 1 \text{ mA}$ , $V_{DRIVE} = 1.65 \text{ V to } 3.6 \text{ V}$
SDO Floating State Leakage Current			$\pm 1$	$\mu\text{A}$	Pin three-state, leakage measured to GND and $DV_{CC}$
GPO Floating State Leakage Current	-5		2	$\mu\text{A}$	Pin three-state, leakage measured to GND and $DV_{CC}$
<b>POWER</b>					
$AV_{CC}$ , $DV_{CC}$	2.6	3.3	3.6	V	
$V_{DRIVE}$	1.65		3.6	V	Serial interface operating voltage
$I_{CC}$		0.9	1	mA	In full power mode
			20	$\mu\text{A}$	Low power mode, converter idle, $T_A = 25^{\circ}\text{C}$
		16	33	$\mu\text{A}$	Low power mode, converter idle
			4.5	$\mu\text{A}$	Full shutdown, $T_A = 25^{\circ}\text{C}$
		2.25	18	$\mu\text{A}$	Full shutdown

<sup>1</sup>  $C_{IN}$  and  $C_{BULK}$  are defined in Figure 2.

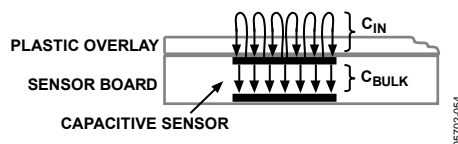

Figure 2.

Table 2. Typical Average Current in Low Power Mode,  $AV_{CC}$ ,  $DV_{CC} = 3.6$  V,  $T = 25^{\circ}\text{C}$ , Load of 50 pF on SRC Pin, No Load on  $\overline{\text{SRC}}$ 

Low Power Mode Delay	Decimation Rate	Number of Conversion Stages (Current Values Expressed in $\mu\text{A}$ )											
		1	2	3	4	5	6	7	8	9	10	11	12
200 ms	128	26.4	33.3	40.1	46.9	53.5	60	66.5	72.8	79.1	85.2	91.3	97.3
	256	35.6	49.1	62.2	74.9	87.3	99.3	111	122.3	133.4	144.2	154.7	164.9
400 ms	128	21.3	24.8	28.3	31.7	35.2	38.6	42	45.4	48.7	52	55.3	58.6
	256	26	32.9	39.7	46.5	53.1	59.6	66.1	72.4	78.7	84.9	91	97
600 ms	128	19.6	21.9	24.3	26.6	28.9	31.2	33.5	35.8	38.1	40.4	42.6	44.8
	256	22.7	27.4	32	36.6	41.1	45.6	50	54.4	58.8	63.1	67.4	71.6
800 ms	128	18.7	20.5	22.2	24	25.7	27.5	29.2	31	32.7	34.4	36.1	37.8
	256	21.1	24.6	28.1	31.5	35	38.4	41.8	45.2	48.5	51.8	55.1	58.4

Table 3. Maximum Average Current in Low Power Mode,  $AV_{CC}$ ,  $DV_{CC} = 3.6$  V, Load of 50 pF on SRC Pin, No Load on  $\overline{\text{SRC}}$ 

Low Power Mode Delay	Decimation Rate	Number of Conversion Stages (Current Values Expressed in $\mu\text{A}$ )											
		1	2	3	4	5	6	7	8	9	10	11	12
200 ms	128	45.4	53.6	61.5	69.4	77.1	84.7	92.2	99.6	106.8	113.9	121	127.9
	256	56.2	72	87.2	102	116.3	130.2	143.7	156.8	169.5	181.8	193.8	205.5
400 ms	128	39.5	43.6	47.7	51.8	55.8	59.8	63.7	67.6	71.5	75.4	79.2	83
	256	45	53.1	61.1	68.9	76.7	84.3	91.8	99.1	106.4	113.6	120.6	127.5
600 ms	128	37.5	40.3	43	45.8	48.5	51.2	53.9	56.5	59.2	61.8	64.5	67.1
	256	41.2	46.7	52.1	57.4	62.7	67.9	73.1	78.2	83.3	88.3	93.3	98.2
800 ms	128	36.5	38.6	40.7	42.7	44.8	46.8	48.8	50.9	52.9	54.9	56.9	58.9
	256	39.3	43.4	47.5	51.5	55.6	59.5	63.5	67.4	71.3	75.2	79	82.8

## SPI TIMING SPECIFICATIONS (AD7142)

$T_A = -40^{\circ}\text{C}$  to  $+85^{\circ}\text{C}$ ;  $V_{\text{DRIVE}} = 1.65\text{ V}$  to  $3.6\text{ V}$ ;  $AV_{\text{CC}}, DV_{\text{CC}} = 2.6\text{ V}$  to  $3.6\text{ V}$ , unless otherwise noted. Sample tested at  $25^{\circ}\text{C}$  to ensure compliance. All input signals are specified with  $t_{\text{R}} = t_{\text{F}} = 5\text{ ns}$  (10% to 90% of  $V_{\text{CC}}$ ) and timed from a voltage level of  $1.6\text{ V}$ .

**Table 4. SPI Timing Specifications**

Parameter	Limit at $T_{\text{MIN}}, T_{\text{MAX}}$	Unit	Description
$f_{\text{SCLK}}$	5	MHz max	
$t_1$	5	ns min	$\overline{\text{CS}}$ falling edge to first SCLK falling edge
$t_2$	20	ns min	SCLK high pulse width
$t_3$	20	ns min	SCLK low pulse width
$t_4$	15	ns min	SDI setup time
$t_5$	15	ns min	SDI hold time
$t_6$	20	ns max	SDO access time after SCLK falling edge
$t_7$	16	ns max	$\overline{\text{CS}}$ rising edge to SDO high impedance
$t_8$	15	ns min	SCLK rising edge to $\overline{\text{CS}}$ high

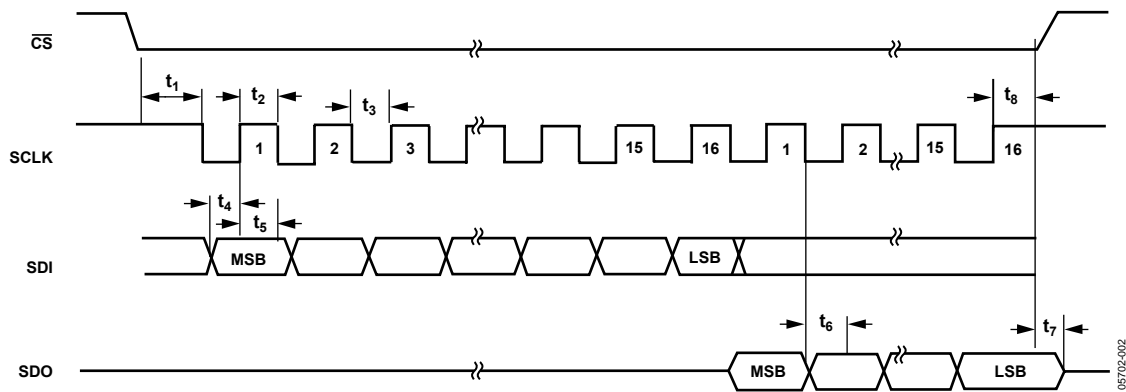

Figure 3. SPI Detailed Timing Diagram

## I<sup>2</sup>C TIMING SPECIFICATIONS (AD7142-1)

$T_A = -40^{\circ}\text{C}$  to  $+85^{\circ}\text{C}$ ;  $V_{\text{DRIVE}} = 1.65\text{ V}$  to  $3.6\text{ V}$ ;  $AV_{\text{CC}}, DV_{\text{CC}} = 2.6\text{ V}$  to  $3.6\text{ V}$ , unless otherwise noted. Sample tested at  $25^{\circ}\text{C}$  to ensure compliance. All input signals timed from a voltage level of  $1.6\text{ V}$ .

Table 5. I<sup>2</sup>C Timing Specifications<sup>1</sup>

Parameter	Limit	Unit	Description
$f_{\text{SCLK}}$	400	kHz max	
$t_1$	0.6	$\mu\text{s}$ min	Start condition hold time, $t_{\text{HD;STA}}$
$t_2$	1.3	$\mu\text{s}$ min	Clock low period, $t_{\text{LOW}}$
$t_3$	0.6	$\mu\text{s}$ min	Clock high period, $t_{\text{HIGH}}$
$t_4$	100	ns min	Data setup time, $t_{\text{SU;DAT}}$
$t_5$	300	ns min	Data hold time, $t_{\text{HD;DAT}}$
$t_6$	0.6	$\mu\text{s}$ min	Stop condition setup time, $t_{\text{SU;STO}}$
$t_7$	0.6	$\mu\text{s}$ min	Start condition setup time, $t_{\text{SU;STA}}$
$t_8$	1.3	$\mu\text{s}$ min	Bus free time between stop and start conditions, $t_{\text{BUF}}$
$t_{\text{R}}$	300	ns max	Clock/data rise time
$t_{\text{F}}$	300	ns max	Clock/data fall time

<sup>1</sup> Guaranteed by design, not production tested.

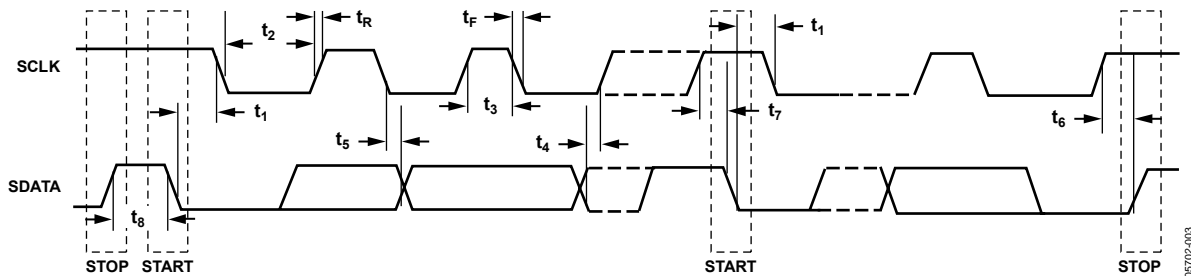

Figure 4. I<sup>2</sup>C Detailed Timing Diagram

05702-003



## ABSOLUTE MAXIMUM RATINGS

Table 6.

Parameter	Rating
$AV_{CC}$ to AGND, $DV_{CC}$ to DGND	-0.3 V to +3.6 V
Analog Input Voltage to AGND	-0.3 V to $AV_{CC} + 0.3$ V
Digital Input Voltage to DGND	-0.3 V to $V_{DRIVE} + 0.3$ V
Digital Output Voltage to DGND	-0.3 V to $V_{DRIVE} + 0.3$ V
Input Current to Any Pin Except Supplies <sup>1</sup>	10 mA
ESD Rating (Human Body Model)	2.5 kV
Operating Temperature Range	-40°C to +150°C
Storage Temperature Range	-65°C to +150°C
Junction Temperature	150°C
LFCSP_VQ	
Power Dissipation	450 mW
$\theta_{JA}$ Thermal Impedance	135.7°C/W
IR Reflow Peak Temperature	260°C ( $\pm 0.5^\circ\text{C}$ )
Lead Temperature (Soldering 10 sec)	300°C

<sup>1</sup>Transient currents of up to 100 mA do not cause SCR latch-up.

Stresses above those listed under Absolute Maximum Ratings may cause permanent damage to the device. This is a stress rating only; functional operation of the device at these or any other conditions above those indicated in the operational section of this specification is not implied. Exposure to absolute maximum rating conditions for extended periods may affect device reliability.

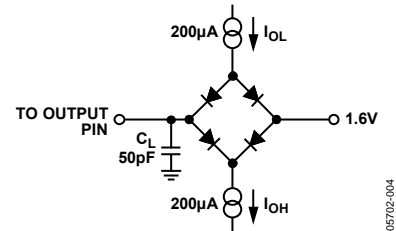

Figure 5. Load Circuit for Digital Output Timing Specifications

### ESD CAUTION



**ESD (electrostatic discharge) sensitive device.** Charged devices and circuit boards can discharge without detection. Although this product features patented or proprietary protection circuitry, damage may occur on devices subjected to high energy ESD. Therefore, proper ESD precautions should be taken to avoid performance degradation or loss of functionality.

## PIN CONFIGURATIONS AND FUNCTION DESCRIPTIONS

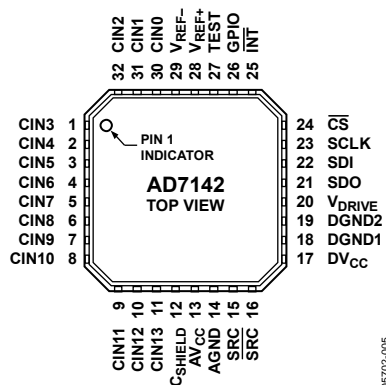

Figure 6. AD7142 Pin Configuration

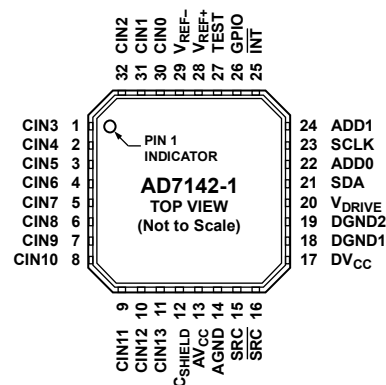

Figure 7. AD7142-1 Pin Configuration

Table 7. Pin Function Descriptions

Pin No.	Mnemonic	Description
1	CIN3	Capacitance Sensor Input.
2	CIN4	Capacitance Sensor Input.
3	CIN5	Capacitance Sensor Input.
4	CIN6	Capacitance Sensor Input.
5	CIN7	Capacitance Sensor Input.
6	CIN8	Capacitance Sensor Input.
7	CIN9	Capacitance Sensor Input.
8	CIN10	Capacitance Sensor Input.
9	CIN11	Capacitance Sensor Input.
10	CIN12	Capacitance Sensor Input.
11	CIN13	Capacitance Sensor Input.
12	CSHIELD	CDC Shield Potential Output. Requires 10 nF capacitor to ground. Connect to external shield.
13	AV <sub>CC</sub>	CDC Supply Voltage.
14	AGND	Analog Ground Reference Point for All CDC Circuitry. Tie to analog ground plane.
15	SRC	CDC Excitation Source Output.
16	$\overline{\text{SRC}}$	Inverted Excitation Source Output.
17	DV <sub>CC</sub>	Digital Core Supply Voltage.
18	DGND1	Digital Ground.
19	DGND2	Digital Ground.
20	V <sub>DRIVE</sub>	Serial Interface Operating Voltage Supply.
21	SDO	(AD7142) SPI Serial Data Output.
	SDA	(AD7142-1) I <sup>2</sup> C Serial Data Input/Output. SDA requires pull-up resistor.
22	SDI	(AD7142) SPI Serial Data Input.
	ADD0	(AD7142-1) I <sup>2</sup> C Address Bit 0.
23	SCLK	Clock Input for Serial Interface.
24	$\overline{\text{CS}}$	(AD7142) SPI Chip Select Signal.
	ADD1	(AD7142-1) I <sup>2</sup> C Address Bit 1.
25	$\overline{\text{INT}}$	General-Purpose Open-Drain Interrupt Output. Programmable polarity; requires pull-up resistor.
26	GPIO	Programmable GPIO.
27	TEST	Factory Test Pin. Tie to ground.
28	V <sub>REF+</sub>	CDC Positive Reference Input. Normally tied to analog power.
29	V <sub>REF-</sub>	CDC Negative Reference Input. Tie to analog ground.
30	CIN0	Capacitance Sensor Input.
31	CIN1	Capacitance Sensor Input.
32	CIN2	Capacitance Sensor Input.

TYPICAL PERFORMANCE CHARACTERISTICS

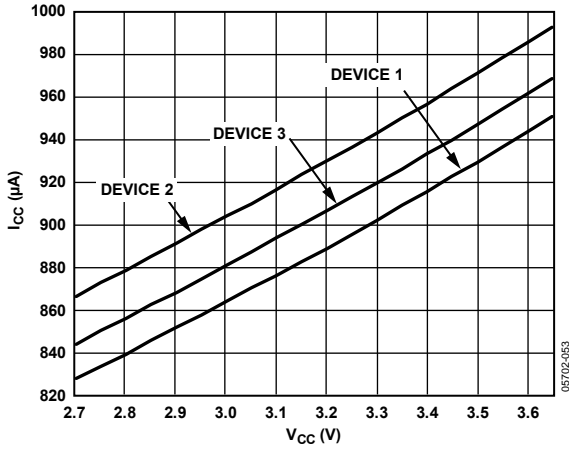

Figure 8. Supply Current vs. Supply Voltage  
 $(V_{CC} = AV_{CC} + DV_{CC}, I_{CC} = AI_{CC} + DI_{CC})$

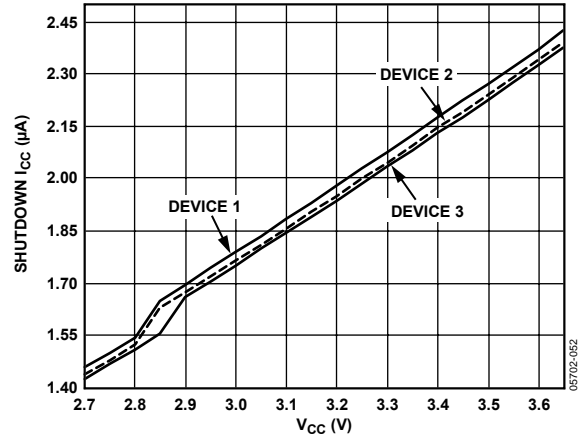

Figure 11. Shutdown Supply Current vs. Supply Voltage  
 $(V_{CC} = AV_{CC} + DV_{CC}, I_{CC} = AI_{CC} + DI_{CC})$

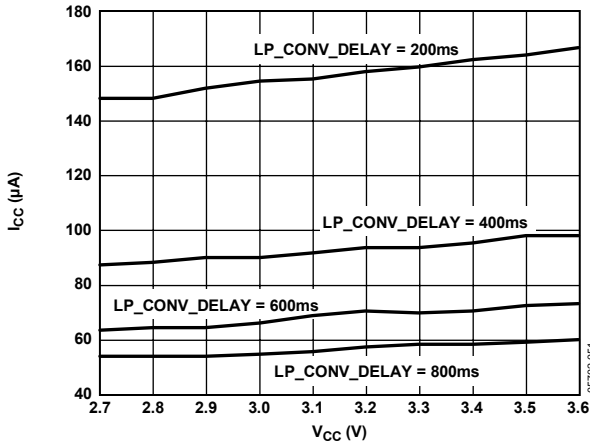

Figure 9. Low Power Supply Current vs. Supply Voltage,  
 Decimation Rate = 256  $(V_{CC} = AV_{CC} + DV_{CC}, I_{CC} = AI_{CC} + DI_{CC})$

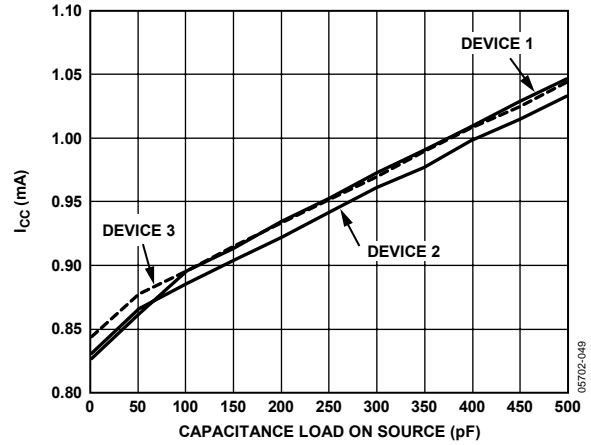

Figure 12. Supply Current vs. Capacitive Load on SRC  $(I_{CC} = AI_{CC} + DI_{CC})$

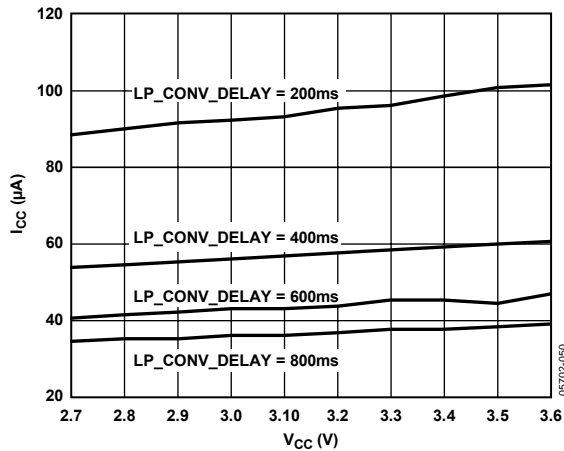

Figure 10. Low Power Supply Current vs. Supply Voltage  
 Decimation Rate = 128  $(V_{CC} = AV_{CC} + DV_{CC}, I_{CC} = AI_{CC} + DI_{CC})$

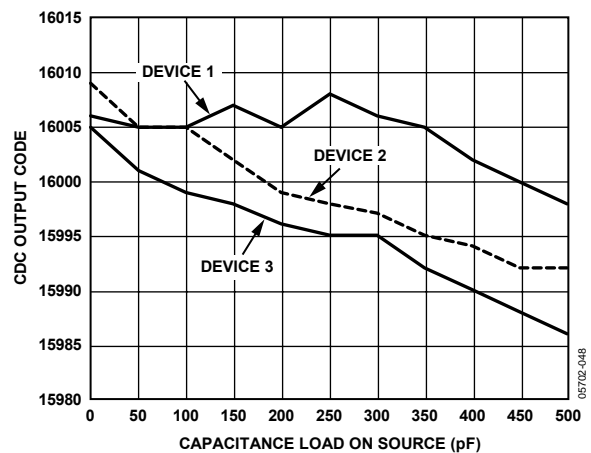

Figure 13. Output Code vs. Capacitive Load on SRC

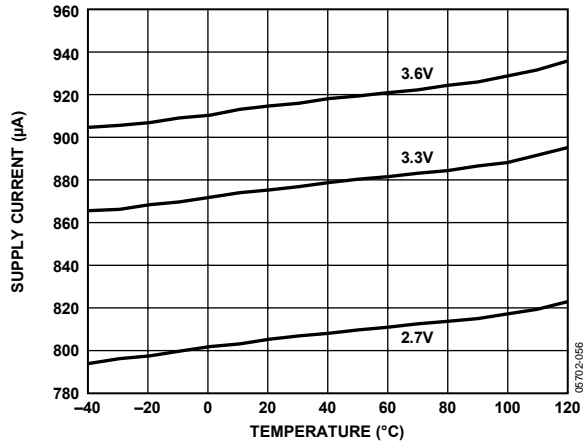

Figure 14. Supply Current vs. Temperature (Supply Current =  $I_{CC} + I_{DC}$ )

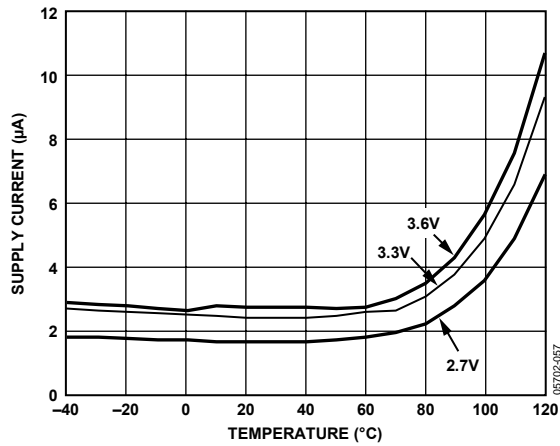

Figure 15. Shutdown Supply Current vs. Temperature (Supply Current =  $I_{CC} + I_{DC}$ )

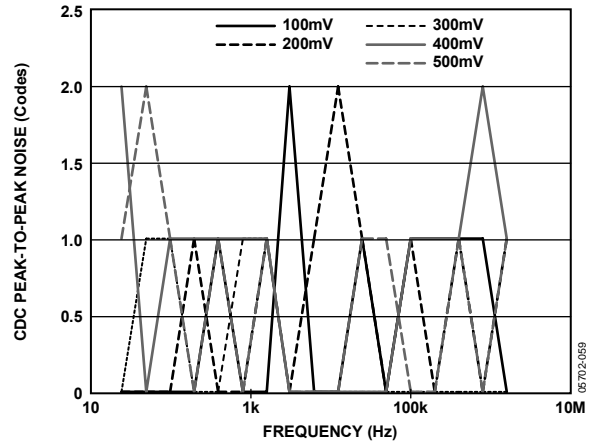

Figure 16. Power Supply Sine Wave Rejection

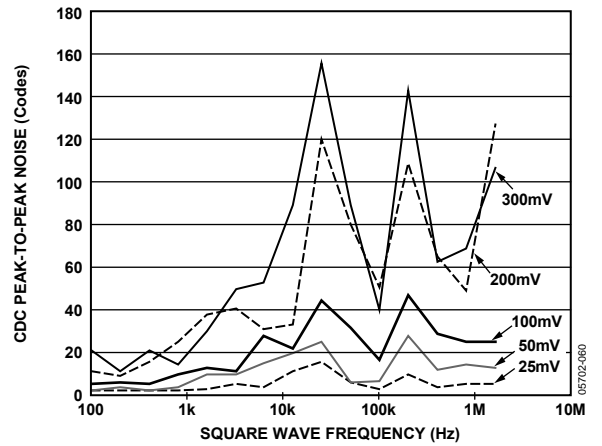

Figure 17. Power Supply Square Wave Rejection

## THEORY OF OPERATION

The AD7142 and AD7142-1 are capacitance-to-digital converters (CDCs) with on-chip environmental compensation, intended for use in portable systems requiring high resolution user input. The internal circuitry consists of a 16-bit,  $\Sigma$ - $\Delta$  converter that converts a capacitive input signal into a digital value. There are 14 input pins on the AD7142 and AD7142-1, CIN0 to CIN13. A switch matrix routes the input signals to the CDC. The result of each capacitance-to-digital conversion is stored in on-chip registers. The host subsequently reads the results over the serial interface. The AD7142 contains an SPI interface and the AD7142-1 has an I<sup>2</sup>C interface ensuring that the parts are compatible with a wide range of host processors. Because the AD7142 and AD7142-1 are identical parts, with the exception of the serial interface, AD7142 refers to both the AD7142 and AD7142-1 throughout this data sheet.

The AD7142 interfaces with up to 14 external capacitance sensors. These sensors can be arranged as buttons, scroll bars, wheels, or as a combination of sensor types. The external sensors consist of electrodes on a single or multiple layer PCB that interfaces directly to the AD7142.

The AD7142 can be set up to implement any set of input sensors by programming the on-chip registers. The registers can also be programmed to control features such as averaging, offsets, and gains for each of the external sensors. There is a sequencer on-chip to control how each of the capacitance inputs is polled.

The AD7142 has on-chip digital logic and 528 words of RAM that are used for environmental compensation. The effects of humidity, temperature, and other environmental factors can effect the operation of capacitance sensors. Transparent to the user, the AD7142 performs continuous calibration to compensate for these effects, allowing the AD7142 to give error-free results at all times.

The AD7142 requires some minor companion software that runs on the host or other microcontroller to implement high resolution sensor functions such as a scroll bar or wheel. However, no companion software is required to implement buttons, including 8-way button functionality. Button sensors are implemented completely in digital logic on-chip.

The AD7142 can be programmed to operate in either full power mode, or in low power automatic wake-up mode. The automatic wake-up mode is particularly suited for portable devices that require low power operation giving the user significant power savings coupled with full functionality.

The AD7142 has an interrupt output,  $\overline{\text{INT}}$ , to indicate when new data has been placed into the registers.  $\overline{\text{INT}}$  is used to interrupt the host on sensor activation. The AD7142 operates from a 2.6 V to 3.6 V supply, and is available in a 32-lead, 5 mm  $\times$  5 mm LFCSP\_VQ.

## CAPACITANCE SENSING THEORY

The AD7142 uses a method of sensing capacitance known as the shunt method. Using this method, an excitation source is connected to a transmitter generating an electric field to a receiver. The field lines measured at the receiver are translated into the digital domain by a  $\Sigma$ - $\Delta$  converter. When a finger, or other grounded object, interferes with the electric field, some of the field lines are shunted to ground and do not reach the receiver (see Figure 18). Therefore, the total capacitance measured at the receiver decreases when an object comes close to the induced field.

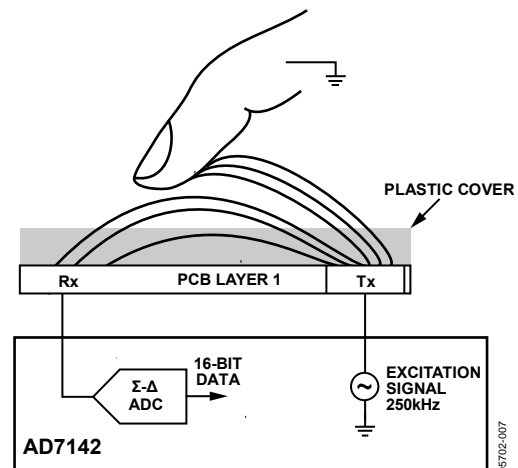

Figure 18. Sensing Capacitance Method

In practice, the excitation source and  $\Sigma$ - $\Delta$  ADC are implemented on the AD7142, and the transmitter and receiver are constructed on a PCB that makes up the external sensor.

### Registering a Sensor Activation

When a sensor is approached, the total capacitance associated with that sensor, measured by the AD7142, changes. When the capacitance changes to such an extent that a set threshold is exceeded, the AD7142 registers this as a sensor touch.

Preprogrammed threshold levels are used to determine if a change in capacitance is due to a button being activated. If the capacitance exceeds one of the threshold limits, the AD7142 registers this as a true button activation. The same thresholds principle is used to determine if other types of sensors, such as sliders or scroll wheels, are activated.

### Complete Solution for Capacitance Sensing

Analog Devices, Inc. provides a complete solution for capacitance sensing. The two main elements to the solution are the sensor PCB and the AD7142.

If the application requires high resolution sensors, such as scroll bars or wheels, software is required that runs on the host processor. (No software is required for button sensors.) The memory requirements for the host depend on the sensor, and are typically 10 kB of code and 600 bytes of data memory.

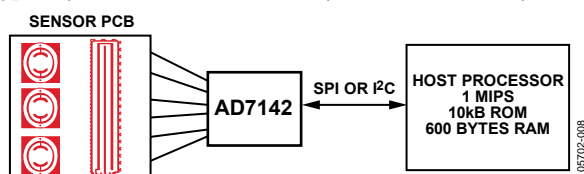

Figure 19. Three Part Capacitance Sensing Solution

Analog Devices supplies the sensor PCB footprint design libraries to the customer based on the customer's specifications, and supplies any necessary software on an open-source basis.

### OPERATING MODES

The AD7142 has three operating modes. Full power mode, where the device is always fully powered, is suited for applications where power is not a concern (for example, game consoles that have an ac power supply). Low power mode, where the part automatically powers down, is tailored to give significant power savings over full power mode, and is suited for mobile applications where power must be conserved. In shutdown mode, the part shuts down completely.

The POWER\_MODE bits (Bit 0 and Bit 1) of the control register set the operating mode on the AD7142. The control register is at Address 0x000. Table 8 shows the POWER\_MODE settings for each operating mode. To put the AD7142 into shutdown mode, set the POWER\_MODE bits to either 01 or 11.

Table 8. POWER\_MODE Settings

POWER_MODE Bits	Operating Mode
00	Full power mode
01	Full shutdown mode
10	Low power mode
11	Full shutdown mode

The power-on default setting of the POWER\_MODE bits is 00, full power mode.

#### Full Power Mode

In full power mode, all sections of the AD7142 remain fully powered at all times. When a sensor is being touched, the AD7142 processes the sensor data. If no sensor is touched, the AD7142 measures the ambient capacitance level and uses this data for the on-chip compensation routines. In full power mode, the AD7142 converts at a constant rate. See the CDC Conversion Sequence Time section for more information.

#### Low Power Mode

When in low power mode, the AD7142 POWER\_MODE bits are set to 10 upon device initialization. If the external sensors are not touched, the AD7142 reduces its conversion frequency, thereby greatly reducing its power consumption. The part remains in a reduced power state when the sensors are not touched. Every LP\_CONV\_DELAY ms (200, 400, 600 or 800 ms), the AD7142 performs a conversion and uses this data to update the compensation logic. When an external sensor is touched, the AD7142 begins a conversion sequence every 36 ms to read back data from the sensors. In low power mode, the total current consumption of the AD7142 is an average of the current used during a conversion, and the current used when the AD7142 is waiting for the next conversion to begin. For example, when LP\_CONV\_DELAY is 400 ms, the AD7142 typically uses 0.9 mA current for 36 ms, and 15  $\mu$ A for 400 ms of the conversion interval. Note that these conversion timings can be altered through the register settings. See the CDC Conversion Sequence Time section for more information.

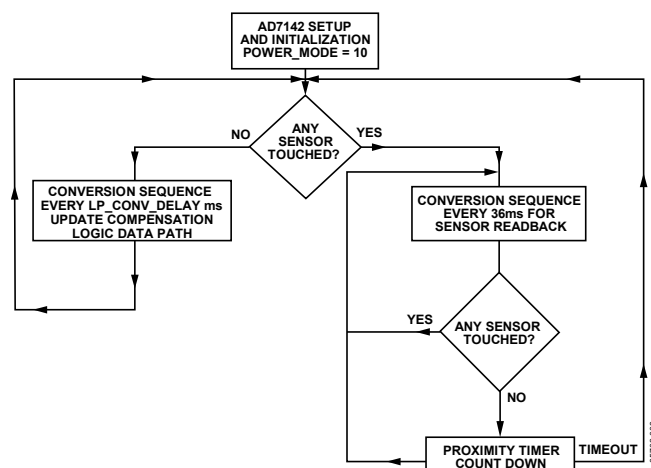

Figure 20. Low Power Mode Operation

The time taken for the AD7142 to go from a full power state to a reduced power state, once the user stops touching the external sensors, is configurable. The PWR\_DWN\_TIMEOUT bits, in Ambient Compensation Ctrl 0 Register, at Address 0x002, control the length of time the AD7142 takes before going into the reduced power state, once the sensors are not touched.

## CAPACITANCE SENSOR INPUT CONFIGURATION

Each input connection from the external capacitance sensors to the AD7142 converter can be uniquely configured by using the registers in Table 45 and Table 46. These registers are used to configure input pin connection setups, sensor offsets, sensor sensitivities, and sensor limits for each stage. Each sensor can be individually optimized. For example, a button sensor connected to STAGE0 can have different sensitivity and offset values than a button with a different function that is connected to a different stage.

### CIN INPUT MULTIPLEXER SETUP

The CIN\_CONNECTION\_SETUP registers in Table 45 list the different options that are provided for connecting the sensor input pin to the CDC.

The AD7142 has an on-chip multiplexer to route the input signals from each pin to the input of the converter. Each input pin can be tied to either the negative or the positive input of the

CDC, or it can be left floating. Each input can also be internally connected to the C<sub>SHIELD</sub> signal to help prevent cross coupling. If an input is not used, always connect it to C<sub>SHIELD</sub>.

Connecting a CIN<sub>x</sub> input pin to the positive CDC input results in a decrease in CDC output code when the corresponding sensor is activated. Connecting a CIN<sub>x</sub> input pin to the negative CDC input results in an increase in CDC output code when the corresponding sensor is activated.

The multiplexer settings for each conversion sequence can be unique and different for each of the input pins, CIN<sub>0</sub> to CIN<sub>13</sub>. For example, CIN<sub>0</sub> is connected to the negative CDC input for conversion STAGE1, left floating for sequencer STAGE1, and so on for all twelve conversion stages.

Two bits in each sequence stage register control the mux setting for the input pin.

CIN <sub>0</sub>	CIN <sub>1</sub>	CIN <sub>2</sub>	CIN <sub>3</sub>	CIN <sub>4</sub>	CIN <sub>5</sub>	CIN <sub>6</sub>	CIN <sub>7</sub>	CIN <sub>8</sub>	CIN <sub>9</sub>	CIN <sub>10</sub>	CIN <sub>11</sub>	CIN <sub>12</sub>	CIN <sub>13</sub>										
<table border="1"> <thead> <tr> <th>CIN_CONNECTION_SETUP BITS</th> <th>CIN SETTING</th> </tr> </thead> <tbody> <tr> <td>00</td> <td>CINX FLOATING</td> </tr> <tr> <td>01</td> <td>CINX CONNECTED TO NEGATIVE CDC INPUT</td> </tr> <tr> <td>10</td> <td>CINX CONNECTED TO POSITIVE CDC INPUT</td> </tr> <tr> <td>11</td> <td>CINX CONNECTED TO C<sub>SHIELD</sub></td> </tr> </tbody> </table>														CIN_CONNECTION_SETUP BITS	CIN SETTING	00	CINX FLOATING	01	CINX CONNECTED TO NEGATIVE CDC INPUT	10	CINX CONNECTED TO POSITIVE CDC INPUT	11	CINX CONNECTED TO C <sub>SHIELD</sub>
CIN_CONNECTION_SETUP BITS	CIN SETTING																						
00	CINX FLOATING																						
01	CINX CONNECTED TO NEGATIVE CDC INPUT																						
10	CINX CONNECTED TO POSITIVE CDC INPUT																						
11	CINX CONNECTED TO C <sub>SHIELD</sub>																						



Figure 21. Input Mux Configuration Options

## CAPACITANCE-TO-DIGITAL CONVERTER

The capacitance-to-digital converter on the AD7142 has a  $\Sigma$ - $\Delta$  architecture with 16-bit resolution. There are 14 possible inputs to the CDC that are connected to the input of the converter through a switch matrix. The sampling frequency of the CDC is 250 kHz.

### OVERSAMPLING THE CDC OUTPUT

The decimation rate, or oversampling ratio, is determined by Bits[9:8] of the control register, as listed in Table 9.

**Table 9. CDC Decimation Rate**

Decimation Bit Value	Decimation Rate	CDC Output Rate Per Stage
00	256	3.072 ms
01	128	1.536 ms
10 <sup>1</sup>	–	–
11 <sup>1</sup>	–	–

<sup>1</sup> Do not use this setting.

The decimation process on the AD7142 is an averaging process where a number of samples are taken and the averaged result is output. Due to the architecture of the digital filter employed, the amount of samples taken (per stage) is equal to 3 times the decimation rate. So  $3 \times 256$  or  $3 \times 128$  samples are averaged to obtain each stage result.

The decimation process reduces the amount of noise present in the final CDC result. However, the higher the decimation rate, the lower the output rate per stage, thus, a trade-off is possible between a noise-free signal and speed of sampling.

### CAPACITANCE SENSOR OFFSET CONTROL

There are two programmable DACs on board the AD7142 to null any capacitance sensor offsets. These offsets are associated with printed circuit board capacitance or capacitance due to any other source, such as connectors. In Figure 22,  $C_{IN}$  is the capacitance of the input sensors, and  $C_{BULK}$  is the capacitance between layers of the sensor PCB.  $C_{BULK}$  can be offset using the on-board DACs.

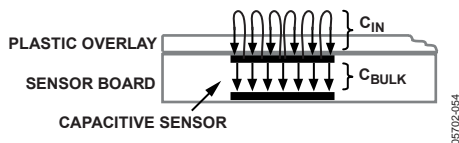

Figure 22. Capacitances Around the Sensor PCB

A simplified block diagram in Figure 23 shows how to apply the STAGE\_OFFSET registers to null the offsets. The 7-bit POS\_AFE\_OFFSET and NEG\_AFE\_OFFSET registers program the offset DAC to provide 0.16 pF resolution offset adjustment over a range of  $\pm 20$  pF. Apply the positive and negative offsets to either the positive or the negative CDC input using the NEG\_AFE\_OFFSET register and POS\_AFE\_OFFSET register.

This process is only required once during the initial capacitance sensor characterization.

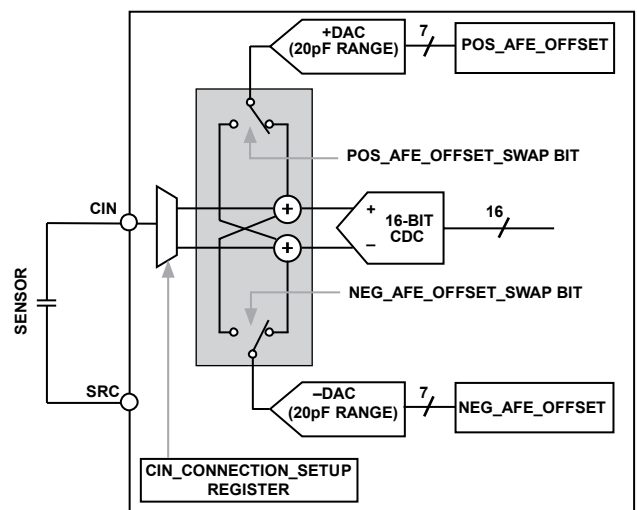

Figure 23. Analog Front-End Offset Control

### CONVERSION SEQUENCER

The AD7142 has an on-chip sequencer to implement conversion control for the input channels. Up to 12 conversion stages can be performed in one sequence. Each of the 12 conversion stages can measure the input from a different sensor. By using the Bank 2 registers, each stage can be uniquely configured to support multiple capacitance sensor interface requirements. For example, a slider sensor can be assigned to STAGE1 through STAGE8, with a button sensor assigned to STAGE0.

The AD7142 on-chip sequence controller provides conversion control beginning with STAGE0. Figure 24 shows a block diagram of the CDC conversion stages and CIN inputs. A conversion sequence is defined as a sequence of CDC conversions starting at STAGE0 and ending at the stage determined by the value programmed in the SEQUENCE\_STAGE\_NUM register. Depending on the number and type of capacitance sensors that are used, not all conversion stages are required. Use the SEQUENCE\_STAGE\_NUM register to set the number of conversions in one sequence, depending on the sensor interface requirements. For example, this register would be set to 5 if the CIN inputs were mapped to only six stages. In addition, set the STAGE\_CAL\_EN registers according to the number of stages that are used.



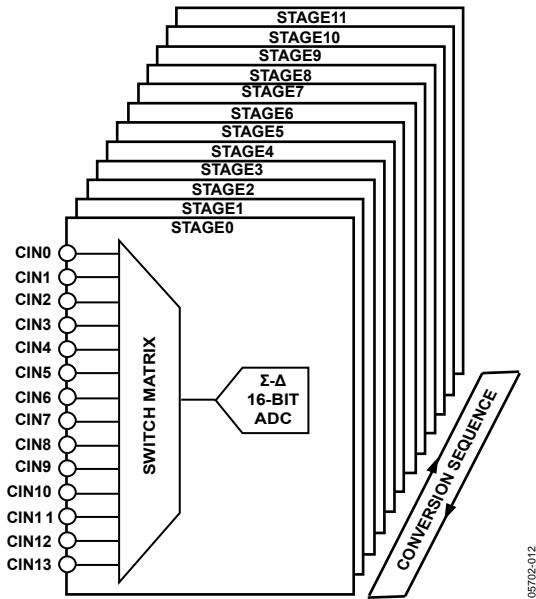

Figure 24. CDC Conversion Stages

The number of required conversion stages depends completely on the number of sensors attached to the AD7142. Figure 25 shows how many conversion stages are required for each sensor, and how many inputs each sensor requires to the AD7142.

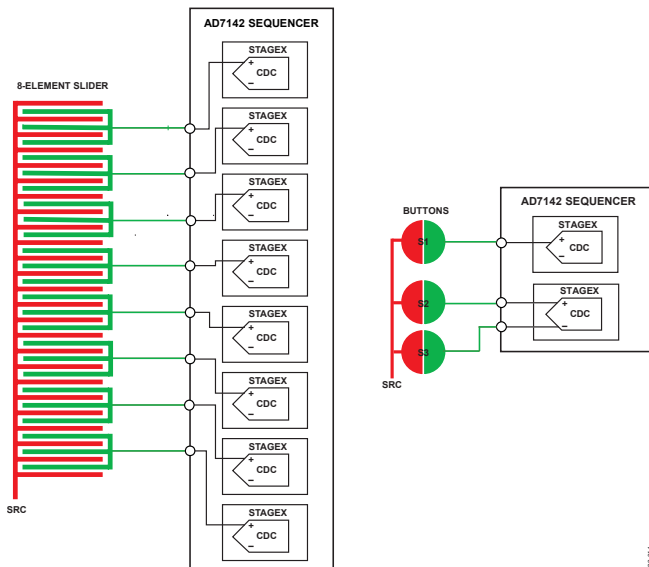

Figure 25. Sequencer Setup for Sensors

A button sensor generally requires one sequencer stage; however, it is possible to configure two button sensors to operate differentially. Only one button from the pair can be activated at a time; pressing both buttons together results in neither button being activated. This configuration requires one conversion stage, and is shown in Figure 25, B2 and B3.

A scroll bar or slider sensor requires eight stages. The result from each stage is used by the host software to determine the user's position on the scroll bar. The algorithm that performs this process is available from Analog Devices free of charge, on signing a software license. Scroll wheels also require eight stages.

The 8-way switch is made from two pairs of differential buttons. It, therefore, requires two conversion stages, one for each of the differential button pairs. It also requires a stage to measure whether the sensor is active. The buttons are orientated so that one pair makes up the top and bottom portions of the 8-way switch; the other pair makes up the left and right portions of the 8-way switch.

**CDC CONVERSION SEQUENCE TIME**

The time required for one complete measurement for all 12 stages by the CDC is defined as the CDC conversion sequence time. The SEQUENCE\_STAGE\_NUM register and DECIMATION register determine the conversion time as listed in Table 10.

Table 10. CDC Conversion Times for Full Power Mode

SEQUENCE_STAGE_NUM	Conversion Time (ms)	
	DECIMATION = 128	DECIMATION = 256
0	1.536	3.072
1	3.072	6.144
2	4.608	9.216
3	6.144	12.288
4	7.68	15.36
5	9.216	18.432
6	10.752	21.504
7	12.288	24.576
8	13.824	27.648
9	15.36	30.72
10	16.896	33.792
11	18.432	36.864

For example, operating with a decimation rate of 128, if the SEQUENCE\_STAGE\_NUM register is set to 5 for the conversion of six stages in a sequence, the conversion sequence time is 9.216 ms.

**Full Power Mode CDC Conversion Sequence Time**

The full power mode CDC conversion sequence time for all 12 stages is set by configuring the SEQUENCE\_STAGE\_NUM register, and DECIMATION register as outlined in Table 10.

Figure 26 shows a simplified timing diagram of the full power CDC conversion time. The full power mode CDC conversion time,  $t_{CONV\_FP}$ , is set using Table 10.

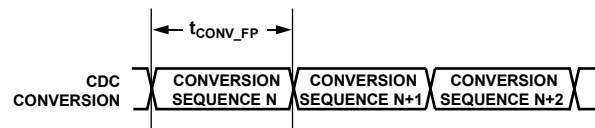

- NOTES  
1.  $t_{CONV\_FP}$  = VALUE SET FROM TABLE 10.

Figure 26. Full Power Mode CDC Conversion Sequence Time

### Low Power Mode CDC Conversion Sequence Time with Delay

The frequency of each CDC conversion operating in the low power automatic wake-up mode is controlled by using the LP\_CONV\_DELAY register located at Address 0x000[3:2], in addition to the registers listed in Table 10. This feature provides some flexibility for optimizing the conversion time to meet system requirements vs. AD7142 power consumption.

For example, maximum power savings is achieved when the LP\_CONV\_DELAY register is set to 3. With a setting of 3, the AD7142 automatically wakes up, performing a conversion every 800 ms.

**Table 11. LP\_CONV\_DELAY Settings**

LP_CONV_DELAY Bits	Delay Between Conversions
00	200 ms
01	400 ms
10	600 ms
11	800 ms

Figure 27 shows a simplified timing example of the low power CDC conversion time. As shown, the low power CDC conversion time is set by  $t_{CONV\_FP}$  and the LP\_CONV\_DELAY register.

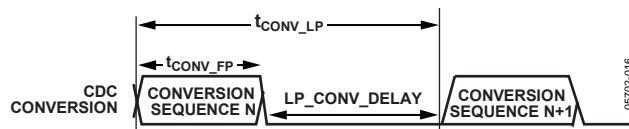

Figure 27. Low Power Mode CDC Conversion Sequence Time

### CDC CONVERSION RESULTS

Certain high resolution sensors require the host to read back the CDC conversion results for processing. The registers required for host processing are located in the Bank 3 registers. The host processes the data readback from these registers using a software algorithm, to determine position information.

In addition to the results registers in the Bank 3 registers, the AD7142 provides the 16-bit CDC output data directly, starting at Address 0x00B of Bank 1. Reading back the CDC 16-bit conversion data register allows for customer-specific application data processing.

## NONCONTACT PROXIMITY DETECTION

The AD7142 internal signal processing continuously monitors all capacitance sensors for noncontact proximity detection. This feature provides the ability to detect when a user is approaching a sensor, at which time all internal calibration is immediately disabled and the AD7142 is automatically configured to detect a valid contact.

The proximity control register bits are described in Table 12. The FP\_PROXIMITY\_CNT register bits and LP\_PROXIMITY\_CNT register bits control the length of the calibration disable period after the user leaves the sensor and proximity is no longer active, in full and low power modes. The calibration is disabled during this time and enabled again at the end of this period provided that the user is no longer approaching, or in contact with, the sensor. Figure 28 and Figure 29 show examples of how these registers are used to set the full and low power mode calibration disable periods.

Calibration disable period in full power mode =  
 $FP\_PROXIMITY\_CNT \times 16 \times \text{Time taken for one conversion sequence in full power mode}$

Calibration disable period in low power mode =  
 $LP\_PROXIMITY\_CNT \times 4 \times \text{Time taken for one conversion sequence in low power mode}$

### RECALIBRATION

In certain situations, the proximity flag can be set for a long period, for example when a user hovers over a sensor for a long time. The environmental calibration on the AD7142 is suspended when proximity is detected, but changes may occur to the ambient capacitance level during the proximity event. This means the ambient value stored on the AD7142 no longer represents the actual ambient value. In this case, even when the user has left the sensor, the proximity flag may still be set. This situation could occur if the user interaction creates some moisture on the sensor causing the new sensor ambient value to be different from the expected value. In this situation, the AD7142 automatically forces a recalibration internally. This ensures that the ambient values are recalibrated regardless of how long the user hovers over a sensor. A recalibration ensures maximum AD7142 sensor performance.

The AD7142 recalibrates automatically when the measured CDC value exceeds the stored ambient value by an amount

determined by PROXIMITY\_RECAL\_LVL, for a set period of time known as the recalibration timeout. In full power mode, the recalibration timeout is controlled by FP\_PROXIMITY\_RECAL, and in low power mode, by LP\_PROXIMITY\_RECAL.

Recalibration timeout in full power mode =  
 $FP\_PROXIMITY\_RECAL \times \text{Time taken for one conversion sequence in full power mode}$

Recalibration timeout in low power mode =  
 $LP\_PROXIMITY\_RECAL \times \text{Time taken for one conversion sequence in low power mode}$

Figure 30 and Figure 31 show examples of how the FP\_PROXIMITY\_RECAL and LP\_PROXIMITY\_RECAL register bits control the timeout period before a recalibration, operating in the full and low power modes. These figures show a user approaching a sensor followed by the user leaving the sensor and the proximity detection remains active after the user leaves the sensor. The measured CDC value exceeds the stored ambient value by the amount set in the PROXIMITY\_RECAL\_LVL bits, for the entire timeout period. The sensor is automatically recalibrated at the end of the timeout period. The forced recalibration takes two interrupt cycles, therefore, it should not be set again during this interval.

### PROXIMITY SENSITIVITY

The fast filter in Figure 32 is used to detect when someone is close to the sensor (proximity). Two conditions set the internal proximity detection signal using Comparator 1 and Comparator 2. Comparator 1 detects when a user is approaching a sensor. The PROXIMITY\_DETECTION\_RATE register controls the sensitivity of Comparator 1. For example, if PROXIMITY\_DETECTION\_RATE is set to 4, the Proximity 1 signal is set when the absolute difference between WORD1 and WORD3 exceeds four LSB codes. Comparator 2 detects when a user hovers over a sensor or approaches a sensor very slowly. The PROXIMITY\_RECAL\_LVL register (Address 0x003) controls the sensitivity of Comparator 2. For example, if PROXIMITY\_RECAL\_LVL is set to 75, the Proximity 2 signal is set when the absolute difference between the fast filter average value and the ambient value exceeds 75 LSB codes.

**Table 12. Proximity Control Registers (See Figure 32)**

Register	Length	Register Address	Description
FP_PROXIMITY_CNT	4 bits	0x002 [7:4]	Calibration disable time in full power mode
LP_PROXIMITY_CNT	4 bits	0x002 [11:8]	Calibration disable time in low power mode
FP_PROXIMITY_RECAL	8 bits	0x004 [9:0]	Full power mode proximity recalibration time
LP_PROXIMITY_RECAL	6 bits	0x004 [15:10]	Low power mode proximity recalibration time
PROXIMITY_RECAL_LVL	8 bits	0x003 [13:8]	Proximity recalibration level
PROXIMITY_DETECTION_RATE	6 bits	0x003 [7:0]	Proximity detection rate

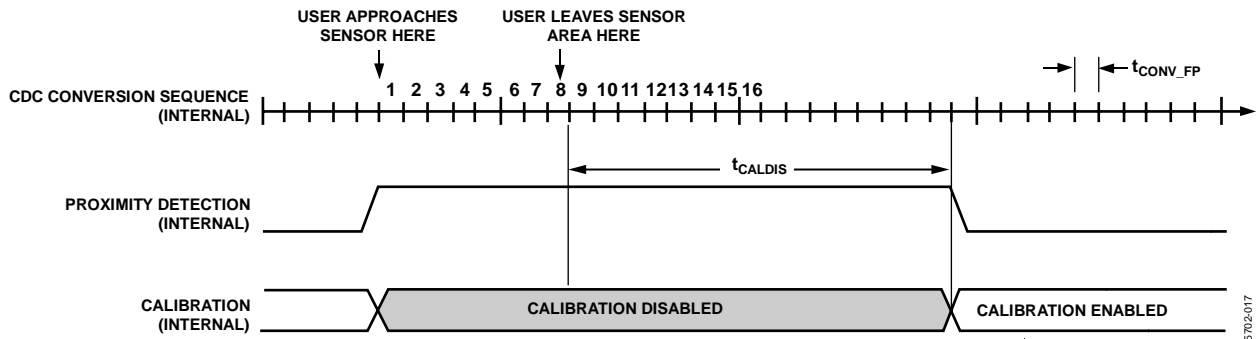
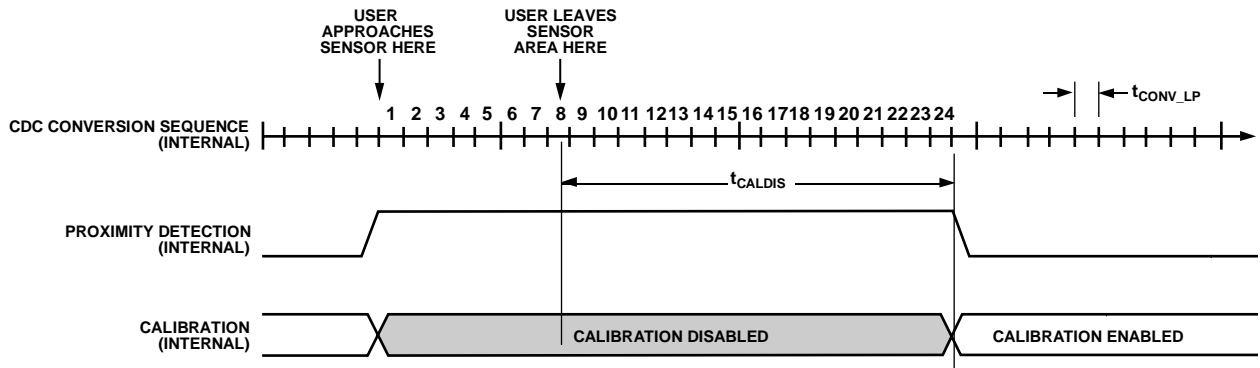

Figure 28. Full Power Mode Proximity Detection Example with  $FP\_PROXIMITY\_CNT = 1$



NOTES

1. SEQUENCE CONVERSION TIME  $t_{CONV\_LP} = t_{CONV\_FP} + LP\_CONV\_DELAY$
2. PROXIMITY IS SET WHEN USER APPROACHES THE SENSOR AT WHICH TIME THE INTERNAL CALIBRATION IS DISABLED.
3.  $t_{CALDIS} = (t_{CONV\_LP} \times LP\_PROXIMITY\_CNT \times 4)$

Figure 29. Low Power Mode Proximity Detection with  $LP\_PROXIMITY\_CNT = 4$

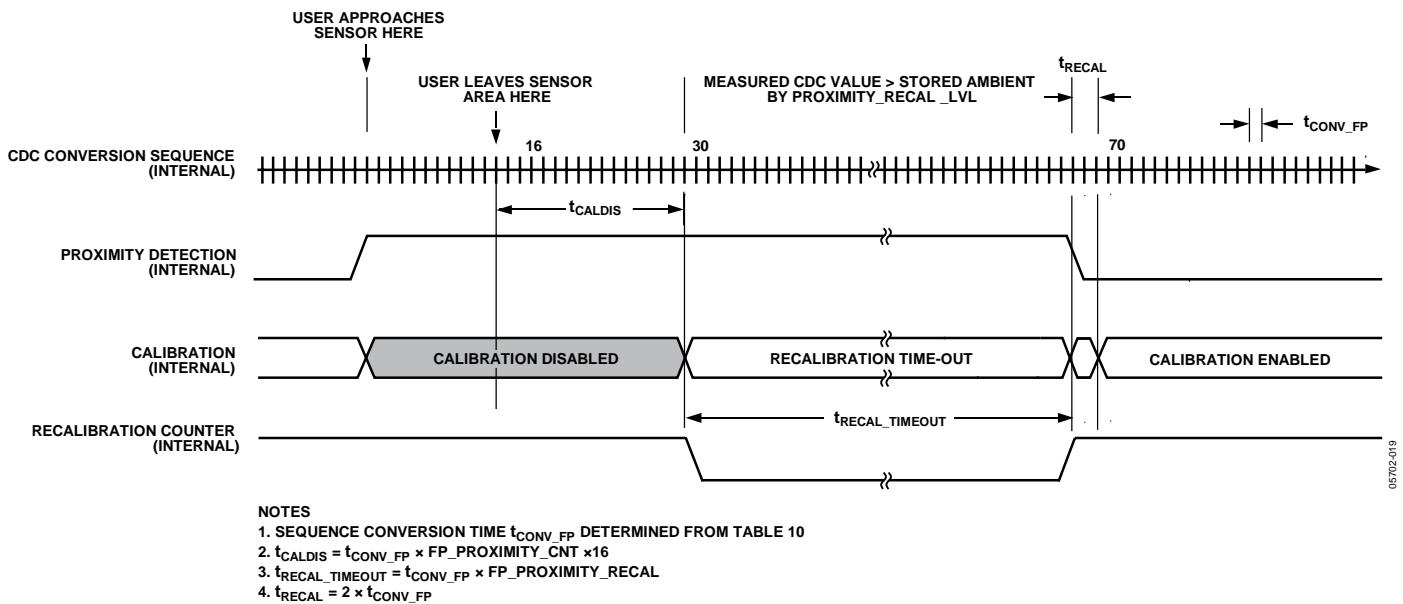

NOTES

1. SEQUENCE CONVERSION TIME  $t_{CONV\_FP}$  DETERMINED FROM TABLE 10
2.  $t_{CALDIS} = t_{CONV\_FP} \times FP\_PROXIMITY\_CNT \times 16$
3.  $t_{RECAL\_TIMEOUT} = t_{CONV\_FP} \times FP\_PROXIMITY\_RECAL$
4.  $t_{RECAL} = 2 \times t_{CONV\_FP}$

Figure 30. Full Power Mode Proximity Detection with Forced Recalibration Example with  $FP\_PROXIMITY\_CNT = 1$  and  $FP\_PROXIMITY\_RECAL = 40$

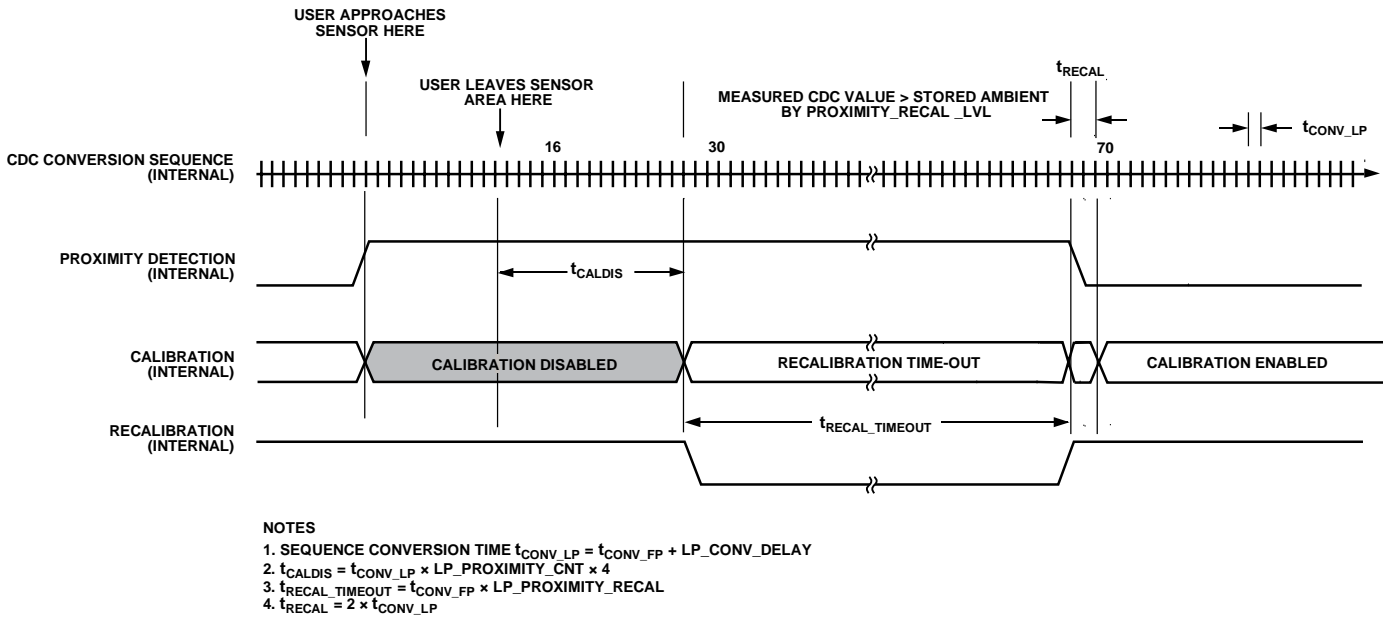

Figure 31. Low Power Mode Proximity Detection with Forced Recalibration Example with  $LP\_PROXIMITY\_CNT = 4$  and  $LP\_PROXIMITY\_RECAL = 40$

## FF\_SKIP\_CNT

The proximity detection fast FIFO is used by the on-chip logic to determine if proximity is detected. The fast FIFO expects to receive samples from the converter at a set rate.  $FF\_SKIP\_CNT$  is used to normalize the frequency of the samples going into the FIFO, regardless of how many conversion stages are in a sequence. In Register 0x02, Bits[3:0] are the fast filter skip control,  $FF\_SKIP\_CNT$ . This value determines which CDC samples are not used (skipped) in the proximity detection fast FIFO.

Determining the  $FF\_SKIP\_CNT$  value is required only once during the initial setup of the capacitance sensor interface. Table 13 shows how  $FF\_SKIP\_CNT$  controls the update rate to the fast FIFO. Recommended value for this setting when using all 12 conversion stages on the AD7142 is  $FF\_SKIP\_CNT = 0000 =$  no samples skipped.

Table 13.  $FF\_SKIP\_CNT$  Settings

FF_SKIP_CNT	FAST FIFO Update Rate	
	DECIMATION = 128	DECIMATION = 256
0	$1.536 \times (SEQUENCE\_STAGE\_NUM + 1)$ ms	$3.072 \times (SEQUENCE\_STAGE\_NUM + 1)$ ms
1	$3.072 \times (SEQUENCE\_STAGE\_NUM + 1)$ ms	$6.144 \times (SEQUENCE\_STAGE\_NUM + 1)$ ms
2	$4.608 \times (SEQUENCE\_STAGE\_NUM + 1)$ ms	$9.216 \times (SEQUENCE\_STAGE\_NUM + 1)$ ms
3	$6.144 \times (SEQUENCE\_STAGE\_NUM + 1)$ ms	$12.288 \times (SEQUENCE\_STAGE\_NUM + 1)$ ms
4	$7.68 \times (SEQUENCE\_STAGE\_NUM + 1)$ ms	$15.36 \times (SEQUENCE\_STAGE\_NUM + 1)$ ms
5	$9.216 \times (SEQUENCE\_STAGE\_NUM + 1)$ ms	$18.432 \times (SEQUENCE\_STAGE\_NUM + 1)$ ms
6	$10.752 \times (SEQUENCE\_STAGE\_NUM + 1)$ ms	$21.504 \times (SEQUENCE\_STAGE\_NUM + 1)$ ms
7	$12.288 \times (SEQUENCE\_STAGE\_NUM + 1)$ ms	$24.576 \times (SEQUENCE\_STAGE\_NUM + 1)$ ms
8	$13.824 \times (SEQUENCE\_STAGE\_NUM + 1)$ ms	$27.648 \times (SEQUENCE\_STAGE\_NUM + 1)$ ms
9	$15.36 \times (SEQUENCE\_STAGE\_NUM + 1)$ ms	$30.72 \times (SEQUENCE\_STAGE\_NUM + 1)$ ms
10	$16.896 \times (SEQUENCE\_STAGE\_NUM + 1)$ ms	$33.792 \times (SEQUENCE\_STAGE\_NUM + 1)$ ms
11	$18.432 \times (SEQUENCE\_STAGE\_NUM + 1)$ ms	$36.864 \times (SEQUENCE\_STAGE\_NUM + 1)$ ms
12	$19.968 \times (SEQUENCE\_STAGE\_NUM + 1)$ ms	$39.936 \times (SEQUENCE\_STAGE\_NUM + 1)$ ms
13	$21.504 \times (SEQUENCE\_STAGE\_NUM + 1)$ ms	$43.008 \times (SEQUENCE\_STAGE\_NUM + 1)$ ms
14	$23.04 \times (SEQUENCE\_STAGE\_NUM + 1)$ ms	$46.08 \times (SEQUENCE\_STAGE\_NUM + 1)$ ms
15	$24.576 \times (SEQUENCE\_STAGE\_NUM + 1)$ ms	$49.152 \times (SEQUENCE\_STAGE\_NUM + 1)$ ms

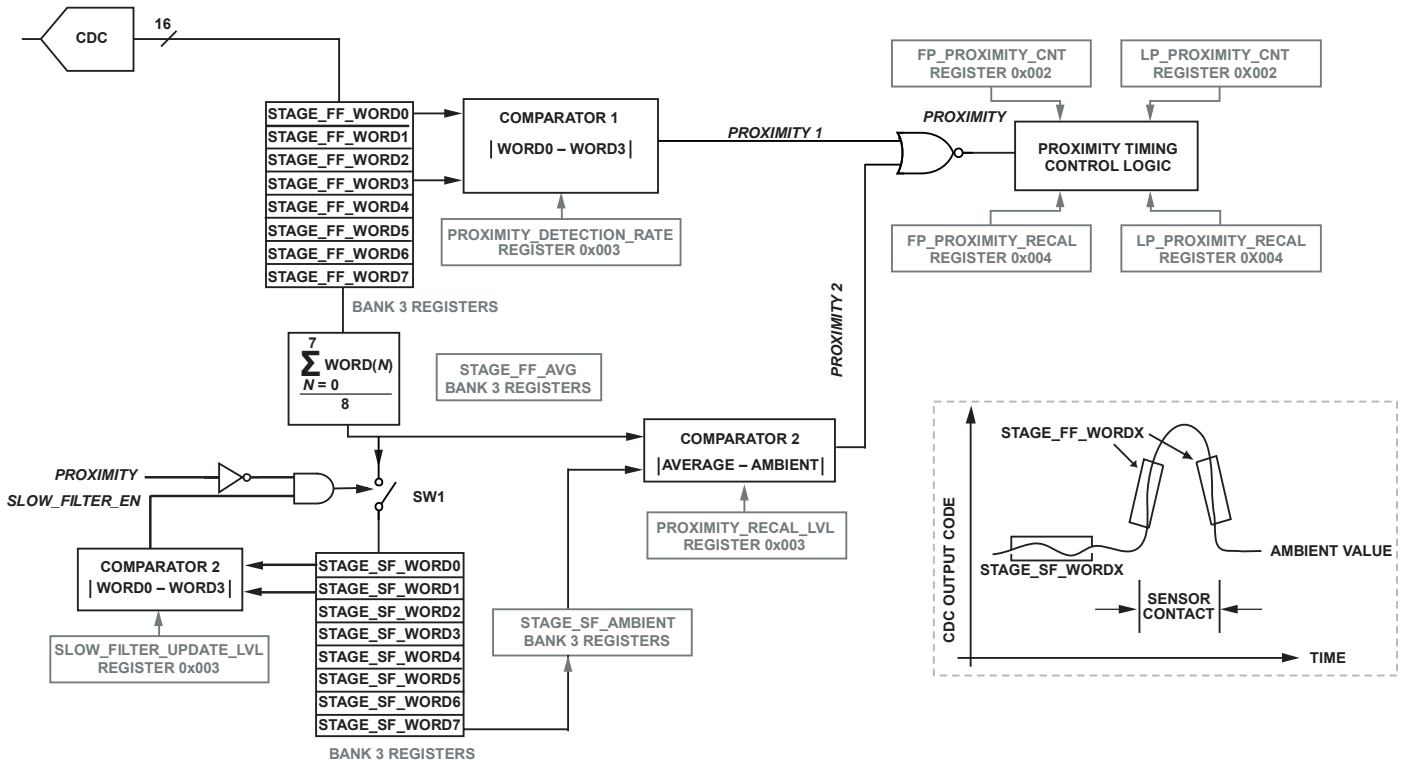

**NOTES**

1. SLOW FILTER EN IS SET AND SW1 IS CLOSED WHEN |STAGE\_SF\_WORD 0–STAGE\_SF\_WORD 1| EXCEEDS THE VALUE PROGRAMMED IN THE SLOW\_FILTER\_UPDATE\_LVL REGISTER PROVIDING PROXIMITY IS NOT SET.
2. PROXIMITY 1 IS SET WHEN |STAGE\_FF\_WORD 0– STAGE\_FF\_WORD 3| EXCEEDS THE VALUE PROGRAMMED IN THE PROXIMITY\_DETECTION\_RATE REGISTER.
3. PROXIMITY 2 IS SET WHEN |AVERAGE–AMBIENT| EXCEEDS THE VALUE PROGRAMMED IN THE PROXIMITY\_RECAL\_LVL REGISTER.
4. DESCRIPTION OF COMPARATOR FUNCTIONS:  
 COMPARATOR 1: USED TO DETECT WHEN A USER IS APPROACHING OR LEAVING A SENSOR.  
 COMPARATOR 2: USED TO DETECT WHEN A USER IS HOVERING OVER A SENSOR, OR APPROACHING A SENSOR VERY SLOWLY.  
 ALSO USED TO DETECT IF THE SENSOR AMBIENT LEVEL HAS CHANGED AS A RESULT OF THE USER INTERACTION.  
 FOR EXAMPLE, HUMIDITY OR DIRT LEFT BEHIND ON SENSOR.  
 COMPARATOR 3: USED TO ENABLE THE SLOW FILTER UPDATE RATE. THE SLOW FILTER IS UPDATED WHEN SLOW FILTER EN IS SET AND PROXIMITY IS NOT SET.

Figure 32. AD7142 Proximity Detection and Environmental Calibration

1707202.01

## ENVIRONMENTAL CALIBRATION

The AD7142 provides on-chip capacitance sensor calibration to automatically adjust for environmental conditions that have an effect on the capacitance sensor ambient levels. Capacitance sensor output levels are sensitive to temperature, humidity, and in some cases, dirt. The AD7142 achieves optimal and reliable sensor performance by continuously monitoring the CDC ambient levels and correcting for any changes by adjusting the `STAGE_HIGH_THRESHOLD` and `STAGE_LOW_THRESHOLD` register values, as described in Equation 1 and Equation 2. The CDC ambient level is defined as the capacitance sensor output level during periods when the user is not approaching or in contact with the sensor.

The compensation logic runs automatically on every conversion after configuration when the AD7142 is not being touched. This allows the AD7142 to account for rapidly changing environmental conditions.

The ambient compensation control registers give the host access to general setup and controls for the compensation algorithm. The RAM stores the compensation data for each conversion stage, as well as setup information specific to each stage.

Figure 33 shows an example of an ideal capacitance sensor behavior where the CDC ambient level remains constant regardless of the environmental conditions. The CDC output shown is for a pair of differential button sensors, where one sensor caused an increase, and the other a decrease in measured capacitance when activated. The positive and negative sensor threshold levels are calculated as a percentage of the `STAGE_OFFSET_HIGH` and `STAGE_OFFSET_LOW` values based on the threshold sensitivity settings and the ambient value. These values are sufficient to detect a sensor contact, resulting with the AD7142 asserting the `INT` output when the threshold levels are exceeded.

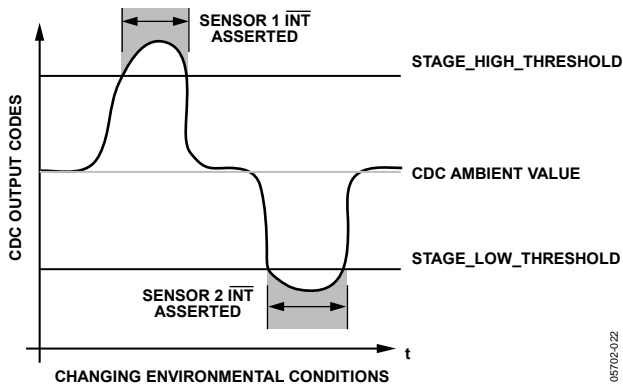

Figure 33. Ideal Sensor Behavior with a Constant Ambient Level

## CAPACITANCE SENSOR BEHAVIOR WITHOUT CALIBRATION

Figure 34 shows the typical behavior of a capacitance sensor with no applied calibration. This figure shows ambient levels drifting over time as environmental conditions change. The ambient level drift has resulted in the detection of a missed user contact on Sensor 2. This is a result of the initial low offset level remaining constant when the ambient levels drifted upward beyond the detection range.

The Capacitance Sensor Behavior with Calibration section describes how the AD7142 adaptive calibration algorithm prevents errors such as this from occurring.

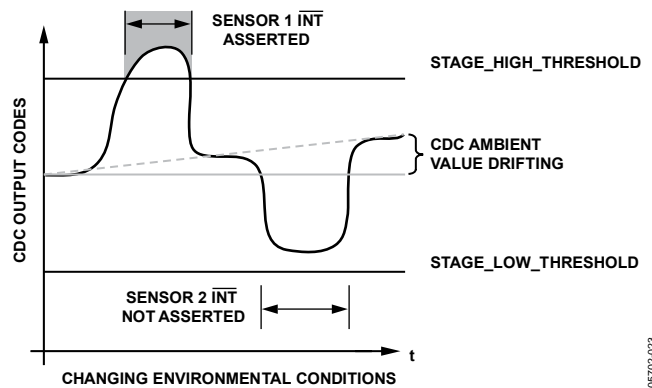
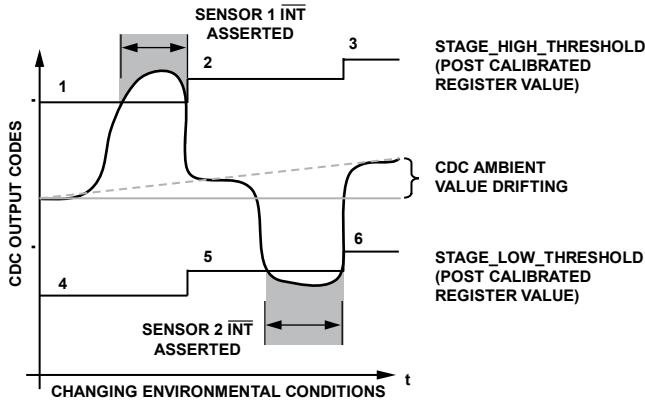

Figure 34. Typical Sensor Behavior Without Calibration Applied

## CAPACITANCE SENSOR BEHAVIOR WITH CALIBRATION

The AD7142 on-chip adaptive calibration algorithm prevents sensor detection errors such as the one shown in Figure 34. This is achieved by monitoring the CDC ambient levels and readjusting the initial `STAGE_OFFSET_HIGH` and `STAGE_OFFSET_LOW` values according to the amount of ambient drift measured on each sensor. The internal `STAGE_HIGH_THRESHOLD` and `STAGE_LOW_THRESHOLD` values described in Equation 1 and Equation 2 are automatically updated based on the new `STAGE_OFFSET_HIGH` and `STAGE_OFFSET_LOW` values. This closed-loop routine ensures the reliability and repeatable operation of every sensor connected to the AD7142 under dynamic environmental conditions. Figure 35 shows a simplified example of how the AD7142 applies the adaptive calibration process resulting in no interrupt errors under changing CDC ambient levels due to environmental conditions.



- NOTES**
1. INITIAL\_STAGE\_OFFSET\_HIGH REGISTER VALUE
  2. POST CALIBRATED REGISTER STAGE\_HIGH\_THRESHOLD
  3. POST CALIBRATED REGISTER STAGE\_HIGH\_THRESHOLD
  4. INITIAL\_STAGE\_LOW\_THRESHOLD
  5. POST CALIBRATED REGISTER STAGE\_LOW\_THRESHOLD
  6. POST CALIBRATED REGISTER STAGE\_LOW\_THRESHOLD

Figure 35. Typical Sensor Behavior with Calibration Applied on the Data Path

**SLOW FIFO**

As shown in Figure 32, there are a number of FIFOs implemented on the AD7142. These FIFOs are located in Bank 3 of the on-chip memory. The slow FIFOs are used by the on-chip logic to monitor the ambient capacitance level from each sensor.

**AVG\_FP\_SKIP and AVG\_LP\_SKIP**

In Register 0x001, Bits[13:12] are the slow FIFO skip control for full power mode, AVG\_FP\_SKIP. Bits[15:14] in the same register are the slow FIFO skip control for low power mode, AVG\_LP\_SKIP. These values determine which CDC samples are not used (skipped) in the slow FIFO. Changing these values slows down or speeds up the rate at which the ambient

capacitance value tracks the measured capacitance value read by the converter.

$$\text{Slow FIFO update rate in full power mode} = \text{AVG\_FP\_SKIP} \times [(3 \times \text{Decimation Rate}) \times (\text{SEQUENCE\_STAGE\_NUM} + 1) \times (\text{FF\_SKIP\_CNT} + 1) \times 4 \times 10^{-7}]$$

$$\text{Slow FIFO update rate in low power mode} = (\text{AVG\_LP\_SKIP} + 1) \times [(3 \times \text{Decimation Rate}) \times (\text{SEQUENCE\_STAGE\_NUM} + 1) \times (\text{FF\_SKIP\_CNT} + 1) \times 4 \times 10^{-7}] / [(\text{FF\_SKIP\_CNT} + 1) + \text{LP\_CONV\_DELAY}]$$

The slow FIFO is used by the on-chip logic to track the ambient capacitance value. The slow FIFO expects to receive samples from the converter at a rate of 33 ms to 40 ms. AVG\_FP\_SKIP and AVG\_LP\_SKIP are used to normalize the frequency of the samples going into the FIFO, regardless of how many conversion stages are in a sequence.

Determining the AVG\_FP\_SKIP and AVG\_LP\_SKIP value is only required once during the initial setup of the capacitance sensor interface. Recommended values for these settings when using all 12 conversion stages on the AD7142 are:

- AVG\_FP\_SKIP = 00 = skip 3 samples
- AVG\_LP\_SKIP = 00 = skip 0 samples

**SLOW\_FILTER\_UPDATE\_LVL**

The SLOW\_FILTER\_UPDATE\_LVL controls whether the most recent CDC measurement goes into the Slow FIFO (slow filter) or not. The slow filter is updated when the difference between the current CDC value and last value pushed into the slow FIFO > SLOW\_FILTER\_UPDATE\_LVL. This variable is in Ambient Control Register 1, at Address 0x003.

$$\text{STAGE\_HIGH\_THRESHOLD} = \text{STAGE\_SF\_AMBIENT} + \left( \frac{\text{STAGE\_OFFSET\_HIGH}}{4} \right) + \left( \frac{\left( \frac{\text{STAGE\_OFFSET\_HIGH} - \text{STAGE\_OFFSET\_HIGH}}{4} \right)}{16} \right) \times \text{POS\_THRESHOLD\_SENSITIVITY}$$

Equation 1. On-Chip Logic Stage High Threshold Calculation

$$\text{STAGE\_LOW\_THRESHOLD} = \text{STAGE\_SF\_AMBIENT} + \left( \frac{\text{STAGE\_OFFSET\_LOW}}{4} \right) + \left( \frac{\left( \frac{\text{STAGE\_OFFSET\_LOW} - \text{STAGE\_OFFSET\_LOW}}{4} \right)}{16} \right) \times \text{NEG\_THRESHOLD\_SENSITIVITY}$$

Equation 2. On-Chip Logic Stage Low Threshold Calculation



## ADAPTIVE THRESHOLD AND SENSITIVITY

The AD7142 provides an on-chip self-learning adaptive threshold and sensitivity algorithm. This algorithm continuously monitors the output levels of each sensor and automatically rescales the threshold levels proportionally to the sensor area covered by the user. As a result, the AD7142 maintains optimal threshold and sensitivity levels for all types of users regardless of their finger sizes.

The threshold level is always referenced from the ambient level and is defined as the CDC converter output level that must be exceeded for a valid sensor contact. The sensitivity level is defined as how sensitive the sensor is before a valid contact is registered.

Figure 36 provides an example of how the adaptive threshold and sensitivity algorithm works. The positive and negative sensor threshold levels are calculated as a percentage of the `STAGE_OFFSET_HIGH` and `STAGE_OFFSET_LOW` values based on the threshold sensitivity settings and the ambient value. On configuration, initial estimates are supplied for both `STAGE_OFFSET_HIGH` and `STAGE_OFFSET_LOW` after which the calibration engine automatically adjusts the `STAGE_HIGH_THRESHOLD` and `STAGE_LOW_THRESHOLD` values for sensor response.

The AD7142 tracks the average maximum and minimum values measured from each sensor. These values give an indication of how the user is interacting with the sensor. A large finger gives

a large average maximum or minimum value, and a small finger gives smaller values. When the average maximum or minimum value changes, the threshold levels are rescaled to ensure that the threshold levels are appropriate for the current user. Figure 37 shows how the minimum and maximum sensor responses are tracked by the on-chip logic.

Reference A in Figure 36 shows an undersensitive threshold level for a small finger user, demonstrating the disadvantages of a fixed threshold level.

By enabling the adaptive threshold and sensitivity algorithm, the positive and negative threshold levels are determined by the `POS_THRESHOLD_SENSITIVITY` and `NEG_THRESHOLD_SENSITIVITY` register values and the most recent average maximum sensor output value. These registers can be used to select 16 different positive and negative sensitivity levels ranging between 25% and 95.32% of the most recent average maximum output level referenced from the ambient value. The smaller the sensitivity percentage setting, the easier it is to trigger a sensor activation. Reference B shows that the positive adaptive threshold level is set at almost mid-sensitivity with a 62.51% threshold level by setting `POS_THRESHOLD_SENSITIVITY = 1000`. Figure 36 also provides a similar example for the negative threshold level with `NEG_THRESHOLD_SENSITIVITY = 0001`.

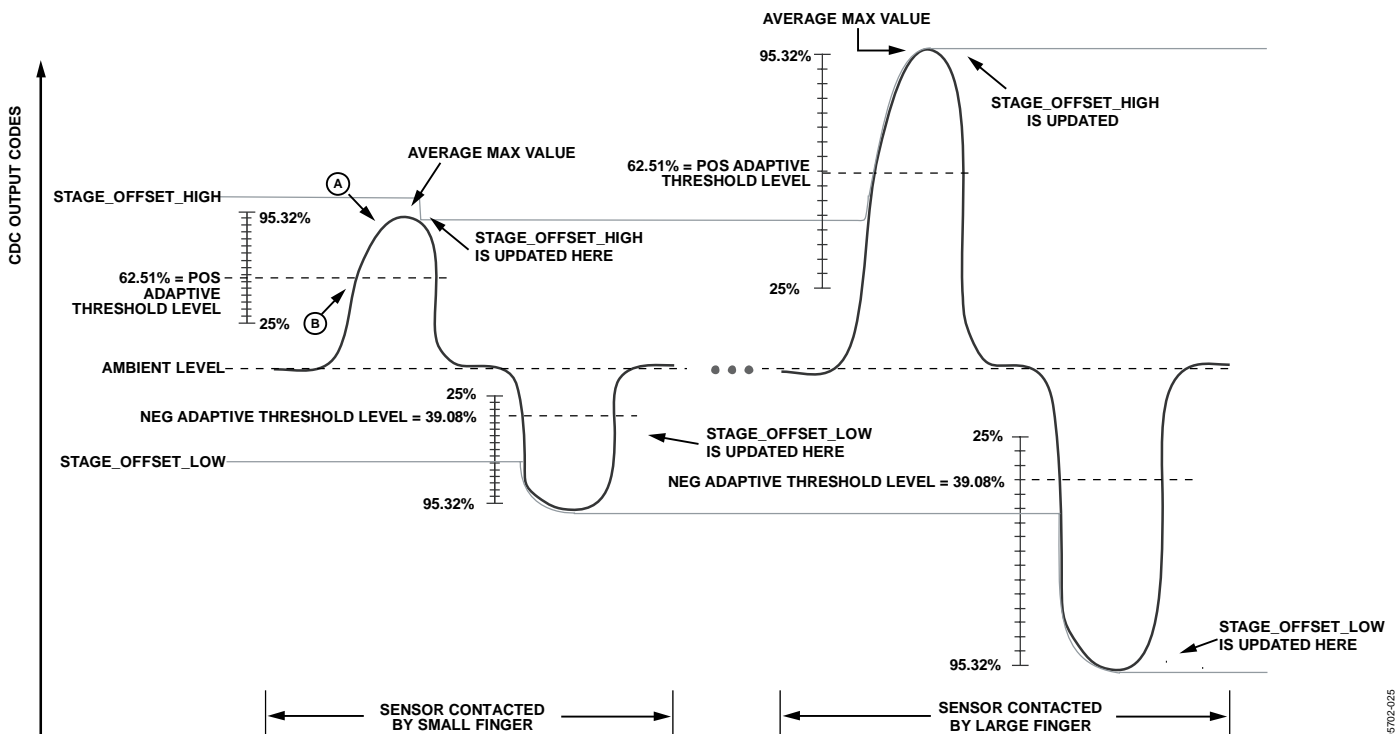

Figure 36. Threshold Sensitivity Example with `POS_THRESHOLD_SENSITIVITY = 1000` and `NEG_THRESHOLD_SENSITIVITY = 0001`

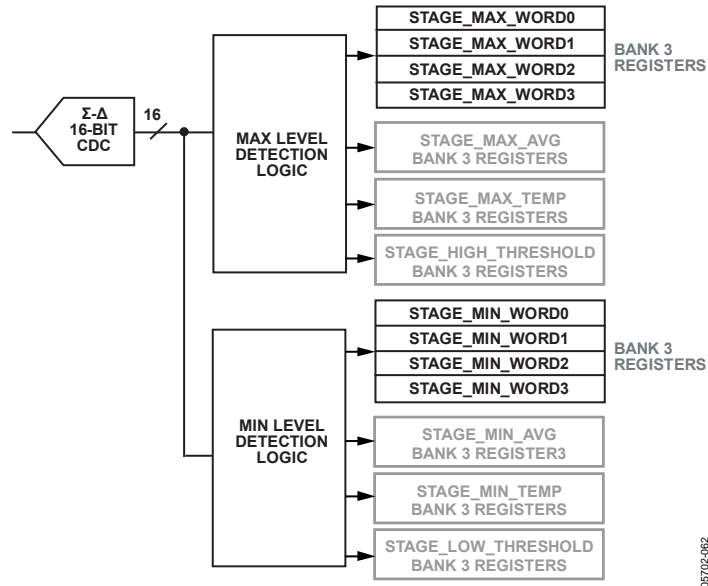

Figure 37. Tracking the Minimum and Maximum Average Sensor Values

Table 13. Additional Information about Environmental Calibration and Adaptive Threshold Registers

Register	Register Location	Description
NEG_THRESHOLD_SENSITIVITY	Bank 2	Used in Equation 2. This value is programmed once at start up.
NEG_PEAK_DETECT	Bank 2	Used by internal adaptive threshold logic only. The NEG_PEAK_DETECT is set to a percentage of the difference between the ambient CDC value, and the min average CDC value. If the output of the CDC gets within the NEG_PEAK_DETECT percentage of the min average, only then is the min average value updated.
POS_THRESHOLD_SENSITIVITY	Bank 2	Used in Equation 1. This value is programmed once at start up.
POS_PEAK_DETECT	Bank 2	Used by internal adaptive threshold logic only. The POS_PEAK_DETECT is set to a percentage of the difference between the ambient CDC value, and the max average CDC value. If the output of the CDC gets within the POS_PEAK_DETECT percentage of the min average, only then is the max average value updated.
STAGE_OFFSET_LOW	Bank 2	Used in Equation 2. An initial value (based on sensor characterization) is programmed into this register at start up. The AD7142 on chip calibration algorithm automatically updates this register based on the amount of sensor drift due to changing ambient conditions. Set to 80% of the STAGE_OFFSET_LOW_CLAMP value.
STAGE_OFFSET_HIGH	Bank 2	Used in Equation 1. An initial value (based on sensor characterization) is programmed into this register at start up. The AD7142 on chip calibration algorithm automatically updates this register based on the amount of sensor drift due to changing ambient conditions. Set to 80% of the STAGE_OFFSET_HIGH_CLAMP value.
STAGE_OFFSET_HIGH_CLAMP	Bank 2	Used by internal environmental calibration and adaptive threshold algorithms only. An initial value (based on sensor characterization) is programmed into this register at start up. The value in this register prevents a user from causing a sensor's output value to exceed the expected nominal value.
STAGE_OFFSET_LOW_CLAMP	Bank 2	Used by internal environmental calibration and adaptive threshold algorithms only. An initial value (based on sensor characterization) is programmed into this register at start up. The value in this register prevents a user from causing a sensor's output value to exceed the expected nominal value.
STAGE_SF_AMBIENT	Bank 3	Set to the minimum expected sensor response, minimum change in CDC output code . Used in Equation 1 and Equation 2. This is the ambient sensor output, when the sensor is not touched, as calculated using the slow FIFO.
STAGE_HIGH_THRESHOLD	Bank 3	Equation 1 value.
STAGE_LOW_THRESHOLD	Bank 3	Equation 2 value.

## INTERRUPT OUTPUT

The AD7142 has an interrupt output that triggers an interrupt service routine on the host processor. The  $\overline{\text{INT}}$  signal is on Pin 25, and is an open-drain output. There are three types of interrupt events on the AD7142: a CDC conversion complete interrupt, a sensor threshold interrupt, and a GPIO interrupt. Each interrupt has enable and status registers. The conversion complete and sensor threshold interrupts can be enabled on a per conversion stage basis. The status registers indicate what type of interrupt triggered the  $\overline{\text{INT}}$  pin. Status registers are cleared, and the  $\overline{\text{INT}}$  signal is reset high, during a read operation. The signal returns high as soon as the read address has been set up.

### CDC CONVERSION COMPLETE INTERRUPT

The AD7142 interrupt signal asserts low to indicate the completion of a conversion stage, and new conversion result data is available in the registers.

The interrupt can be independently enabled for each conversion stage. Each conversion stage complete interrupt can be enabled via the `STAGE_COMPLETE_EN` register (Address 0x007). This register has a bit that corresponds to each conversion stage. Setting this bit to 1 enables the interrupt for that stage. Clearing this bit to 0 disables the conversion complete interrupt for that stage.

In normal operation, the AD7142 interrupt is enabled only for the last stage in a conversion sequence. For example, if there are five conversion stages, the conversion complete interrupt for `STAGE4` is enabled.  $\overline{\text{INT}}$  only asserts when all five conversion stages are complete, and the host can read new data from all five result registers. The interrupt is cleared by reading the `STAGE_COMPLETE_STATUS_INT` register located at Address 0x00A.

Register 0x00A is the conversion complete interrupt status register. Each bit in this register corresponds to a conversion stage. If a bit is set, it means that the conversion complete interrupt for the corresponding stage was triggered. This register is cleared on a read, provided the underlying condition that triggered the interrupt has gone away.

### SENSOR TOUCH INTERRUPT

Use the sensor touch interrupt mode to interrupt the host processor only when the sensor is activated.

Configuring the AD7142 into this mode results in the interrupt being asserted when the user makes contact with the sensor and again when the user lifts off the sensor. The second interrupt is required to alert the host processor that the user is no longer contacting the sensor.

The registers located at Address 0x005 and Address 0x006 are used to enable the interrupt output for each stage. The registers located at Address 0x008 and Address 0x009 are used to read back the interrupt status for each stage.

Figure 38 shows the interrupt output timing during contact with one of the sensors connected to `STAGE0` when operating in the sensor touch interrupt mode. For a low limit configuration, the interrupt output is asserted as soon as the sensor is contacted and again after the user has stopped contacting the sensor.

Note: The interrupt output remains low until the host processor reads back the interrupt status registers located at Address 0x008 and Address 0x009.

The interrupt output is asserted when there is a change in the threshold status bits. This could indicate that a user is now touching the sensor(s) for the first time, the number of sensors being touched has changed, or the user is no longer touching the sensor(s). Reading the status bits in the interrupt status register shows the current sensor activations.

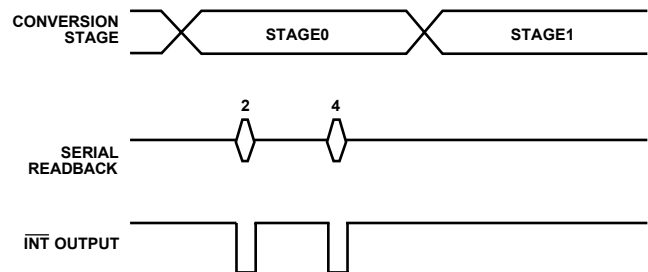

- NOTES:
1. USER TOUCHING DOWN ON SENSOR
  2. ADDRESS 0X008 READ BACK TO CLEAR INTERRUPT
  3. USER LIFTING OFF OF SENSOR
  4. ADDRESS 0X008 READ BACK TO CLEAR INTERRUPT

Figure 38. Example of Sensor Touch Interrupt

05702-055

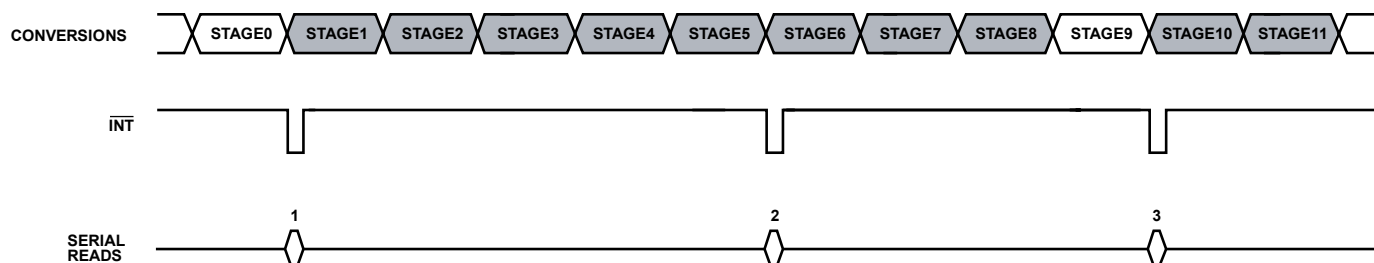
**NOTES**

THIS IS AN EXAMPLE OF A CDC CONVERSION COMPLETE INTERRUPT.

THIS TIMING EXAMPLE SHOWS THAT THE INTERRUPT OUTPUT HAS BEEN ENABLED TO BE ASSERTED AT THE END OF A CONVERSION CYCLE FOR STAGE0, STAGE5, AND STAGE9. THE INTERRUPTS FOR ALL OTHER STAGES HAVE BEEN DISABLED.

STAGE<sub>x</sub> CONFIGURATION PROGRAMMING NOTES FOR STAGE0, STAGE5, AND STAGE9 (x = 0, 5, 9)

STAGE<sub>x</sub>\_LOW\_INT\_EN (ADDRESS 0x005) = 0

STAGE<sub>x</sub>\_HIGH\_INT\_EN (ADDRESS 0x006) = 0

STAGE<sub>x</sub>\_COMPLETE\_EN (ADDRESS 0x007) = 1

STAGE<sub>x</sub> CONFIGURATION PROGRAMMING NOTES FOR STAGE1 THROUGH STAGE8, STAGE10, AND STAGE11 (x = 1, 2, 3, 4, 5, 6, 7, 8, 10, 11)

STAGE<sub>x</sub>\_LOW\_INT\_EN (ADDRESS 0x005) = 0

STAGE<sub>x</sub>\_HIGH\_INT\_EN (ADDRESS 0x006) = 0

STAGE<sub>x</sub>\_COMPLETE\_EN (ADDRESS 0x007) = 0

SERIAL READBACK REQUIREMENTS FOR STAGE0, STAGE5 AND STAGE9. THIS READBACK OPERATION IS REQUIRED TO CLEAR THE INTERRUPT OUTPUT.

1. READ THE STAGE0\_COMPLETE\_STATUS\_INT (ADDRESS 0x00A) REGISTER

2. READ THE STAGE5\_COMPLETE\_STATUS\_INT (ADDRESS 0x00A) REGISTER

3. READ THE STAGE9\_COMPLETE\_STATUS\_INT (ADDRESS 0x00A) REGISTER

Figure 39. Example of Configuring the Registers for End of Conversion Interrupt Setup

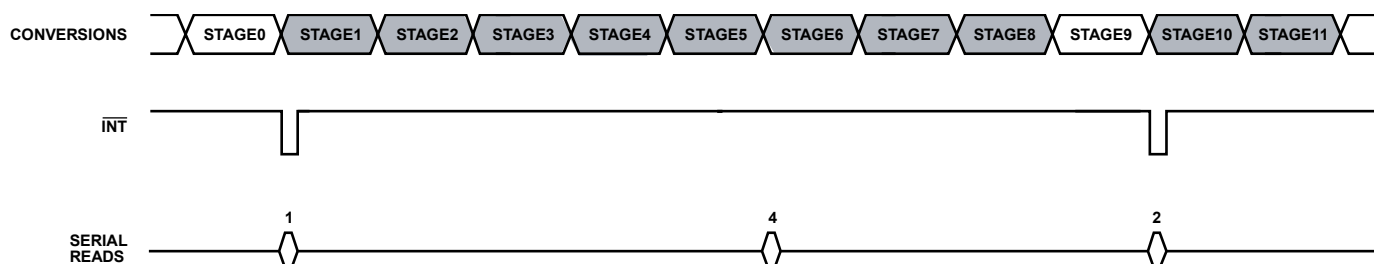
**NOTES**

THIS IS AN EXAMPLE OF A SENSOR THRESHOLD INTERRUPT FOR A CASE WHERE THE LOW THRESHOLD LEVELS WERE EXCEEDED.

FOR EXAMPLE: THE SENSOR CONNECTED TO STAGE0 AND STAGE9 WERE CONTACTED AND THE LOW THRESHOLD LEVELS WERE EXCEEDED RESULTING IN THE INTERRUPT BEING ASSERTED. THE STAGE6 INTERRUPT WAS NOT ASSERTED BECAUSE THE USER DID NOT CONTACT THE SENSOR CONNECTED TO STAGE6.

STAGE<sub>x</sub> CONFIGURATION PROGRAMMING NOTES FOR STAGE0, STAGE6, AND STAGE9 (x = 0, 6, 9)

STAGE<sub>x</sub>\_LOW\_INT\_EN (ADDRESS 0x005) = 1

STAGE<sub>x</sub>\_HIGH\_INT\_EN (ADDRESS 0x006) = 0

STAGE<sub>x</sub>\_COMPLETE\_EN (ADDRESS 0x007) = 0

STAGE<sub>x</sub> CONFIGURATION PROGRAMMING NOTES FOR STAGE1 THROUGH STAGE7, STAGE8, STAGE10, AND STAGE11 (x = 1, 2, 3, 4, 5, 6, 7, 8, 10, 11)

STAGE<sub>x</sub>\_LOW\_INT\_EN (ADDRESS 0x005) = 0

STAGE<sub>x</sub>\_HIGH\_INT\_EN (ADDRESS 0x006) = 0

STAGE<sub>x</sub>\_COMPLETE\_EN (ADDRESS 0x007) = 0

SERIAL READBACK REQUIREMENTS FOR STAGE0 AND STAGE9. THIS READBACK OPERATION IS REQUIRED TO CLEAR THE INTERRUPT OUTPUT.

1. READ THE STAGE0\_LOW\_LIMIT\_INT (ADDRESS 0x008) REGISTER

2. READ THE STAGE5\_LOW\_LIMIT\_INT (ADDRESS 0x008) REGISTER

Figure 40. Example of Configuring the Registers for Sensor Interrupt Setup

## GPIO $\overline{\text{INT}}$ OUTPUT CONTROL

The  $\overline{\text{INT}}$  output signal can be controlled by the GPIO pin when the GPIO is configured as an input. The GPIO is configured as an input by setting the GPIO\_SETUP bits in the interrupt configuration register to 01. See the GPIO section for more information on how to configure the GPIO.

Enable the GPIO interrupt by setting the GPIO\_INT\_EN bit in Register 0x007 to 1, or disable the GPIO interrupt by clearing this bit to 0. The GPIO status bit in the conversion complete interrupt status register reflects the status of the  $\overline{\text{GPIO}}$  interrupt. This bit is set to 1 when the GPIO has triggered  $\overline{\text{INT}}$ . The bit is cleared on readback from the register, provided the condition that caused the interrupt has gone away.

The GPIO interrupt can be set to trigger on a rising edge, falling edge, high level, or low level at the GPIO input pin. Table 14 shows how the settings of the GPIO\_INPUT\_CONFIG bits in the interrupt enable register affect the behavior of  $\overline{\text{INT}}$ .

Figure 41 to Figure 44 show how the interrupt output is cleared on a read from the CDC conversion complete interrupt status register.

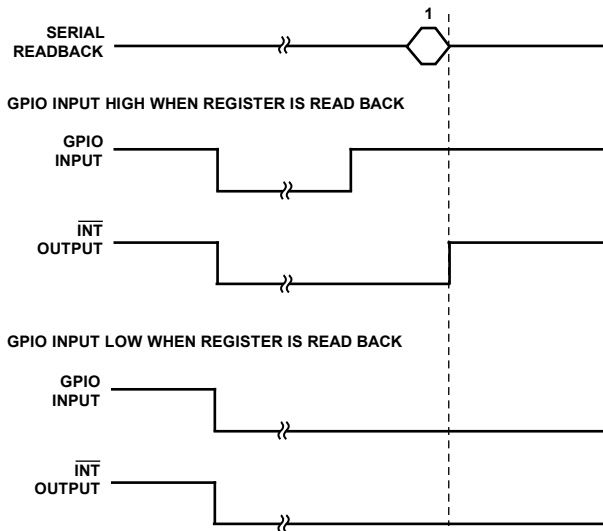

NOTES  
1. READ GPIO\_STATUS REGISTER TO RESET  $\overline{\text{INT}}$  OUTPUT.

05702-028

Figure 41.  $\overline{\text{INT}}$  Output Controlled by the GPIO Input Example, GPIO\_SETUP = 01, GPIO\_INPUT\_CONFIG = 00

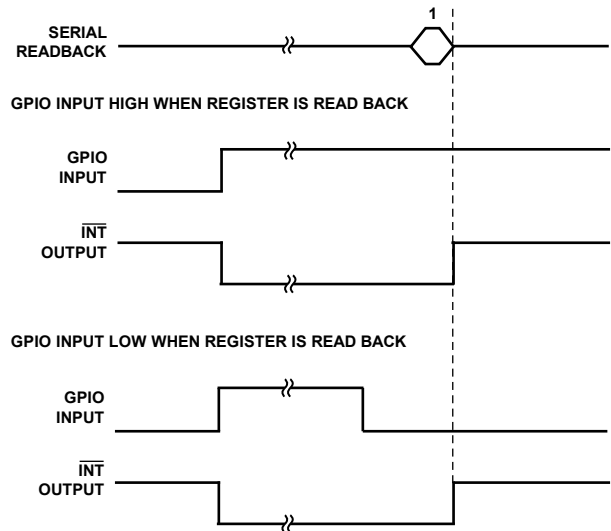

NOTES  
1. READ GPIO\_STATUS REGISTER TO RESET  $\overline{\text{INT}}$  OUTPUT.

05702-028

Figure 42.  $\overline{\text{INT}}$  Output Controlled by the GPIO Input Example, GPIO\_SETUP = 01, GPIO\_INPUT\_CONFIG = 01

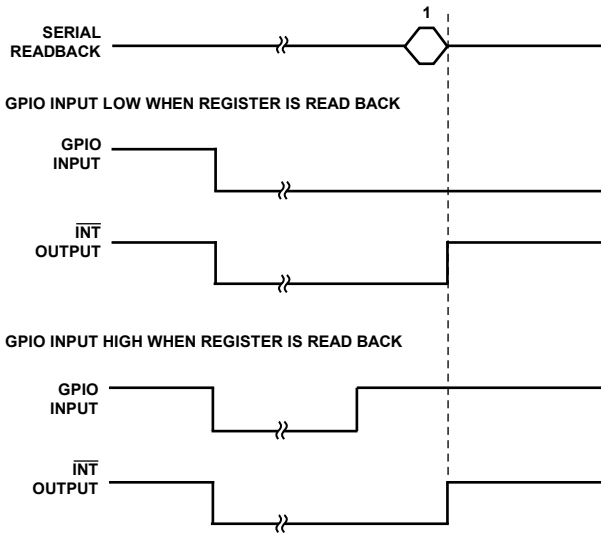

NOTES  
1. READ GPIO\_STATUS REGISTER TO RESET INT OUTPUT.

Figure 43. INT Output Controlled by the GPIO Input Example, GPIO\_SETUP = 01, GPIO\_INPUT\_CONFIG = 10

05702-030

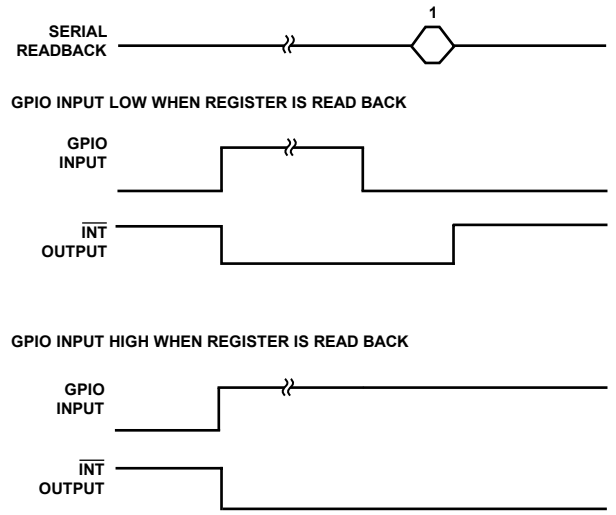

NOTES  
1. READ GPIO\_STATUS REGISTER TO RESET INT OUTPUT.

Figure 44. INT Output Controlled by the GPIO Input Example, GPIO\_SETUP = 01, GPIO\_INPUT\_CONFIG = 11

05702-031

Table 14. GPIO Interrupt Behavior

GPIO_INPUT_CONFIG	GPIO Pin	GPIO_STATUS	INT	INT Behavior
00 = Negative Level Triggered	1	0	1	Not triggered
00 = Negative Level Triggered	0	1	0	Asserted when signal on GPIO pin is low
01 = Positive Edge Triggered	1	1	0	Pulses low at low-to-high GPIO transition
01 = Positive Edge Triggered	0	0	1	Not triggered
10 = Negative Edge Triggered	1	0	1	Pulses low at high-to-low GPIO transition
10 = Negative Edge Triggered	0	1	0	Not triggered
11 = Positive Level Triggered	1	1	0	Asserted when signal on GPIO pin is high
11 = Positive Level Triggered	0	0	1	Not triggered

## OUTPUTS

### EXCITATION SOURCE

The excitation source onboard the AD7142 is a square wave source with a frequency of 250 kHz. This excitation source forms the electric field between the transmitter and receiver in the external capacitance sensor PCB. The source is output from the AD7142 on two pins, the SRC pin and the  $\overline{\text{SRC}}$  pin (outputs an inverted version of the source square wave). The SRC signal offsets large external sensor capacitances.  $\overline{\text{SRC}}$  is not used in the majority of applications.

The source output can be disabled from both output pins separately by writing to the control register bits (Address 0x000[13:12]). Setting Bit 12 in this register to 1 disables the source output on the SRC pin. Setting Bit 13 in this register to 1 disables the inverted source output on the  $\overline{\text{SRC}}$  pin.

### C<sub>SHIELD</sub> OUTPUT

To prevent leakage from the external capacitance sensors, the sensor traces can be shielded. The AD7142 has a voltage output that can be used as the potential for any shield traces, C<sub>SHIELD</sub>. The C<sub>SHIELD</sub> voltage is equal to  $V_{DD}/2$ .

The C<sub>SHIELD</sub> potential is derived from the output of the AD7142 internal amplifier, and is of equal potential to the CIN input lines. Because the shield is at the same potential as the sensor traces, no leakage to ground occurs. To eliminate any ringing on the C<sub>SHIELD</sub> output, connect a 10 nF capacitor between the C<sub>SHIELD</sub> pin and ground. This capacitor is required, whether C<sub>SHIELD</sub> is used in the application or not.

For most applications, C<sub>SHIELD</sub> is not used, and a ground plane is used instead around the sensors.

### GPIO

The AD7142 has one GPIO pin located at Pin 26. It can be configured as an input or an output. The GPIO\_SETUP Bits[13:12] in the interrupt enable register determine how the GPIO pin is configured.

**Table 15. GPIO\_SETUP Bits**

GPIO_SETUP	GPIO Configuration
00	GPIO disabled
01	Input
10	Output low
11	Output high

When the GPIO is configured as an output, the voltage level on the pin is set to either a low level or a high level, as defined by the GPIO\_SETUP bits shown in Table 15.

When the GPIO is configured as an input, the GPIO\_INPUT\_CONFIG bits in the interrupt enable register determine the response of the AD7142 to a signal on the GPIO pin. The GPIO can be configured as either active high or active low, as well as either edge-triggered or level-triggered, as listed in Table 16.

**Table 16. GPIO\_INPUT\_CONFIG Bits**

GPIO_INPUT_CONFIG	GPIO Configuration
00	Triggered on negative level (active low)
01	Triggered on positive edge (active high)
10	Triggered on negative edge (active low)
11	Triggered on positive level (active high)

When GPIO is configured as an input, it triggers the interrupt output on the AD7142. Table 14 lists the interrupt output behavior for each of the GPIO configuration setups.

### USING THE GPIO TO TURN ON/OFF AN LED

The GPIO on the AD7142 can be used to turn on and off LEDs by setting the GPIO as either output high or low. Setting the GPIO output high turns on the LED; setting the GPIO output low turns off the LED. The GPIO pin connects to a transistor that provides the drive current for the LED. Suitable transistors include the KTC3875.

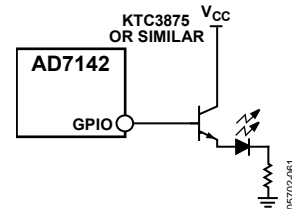

Figure 45. Controlling LEDs Using the GPIO

## SERIAL INTERFACE

The AD7142 is available with an SPI serial interface. The AD7142-1 is available with an I<sup>2</sup>C-compatible interface. Both parts are the same, with the exception of the serial interface.

### SPI INTERFACE

The AD7142 has a 4-wire serial peripheral interface (SPI). The SPI has a data input pin (SDI) for inputting data to the device, a data output pin (SDO) for reading data back from the device, and a data clock pin (SCLK) for clocking data into and out of the device. A chip select pin ( $\overline{CS}$ ) enables or disables the serial interface.  $\overline{CS}$  is required for correct operation of the SPI interface. Data is clocked out of the AD7142 on the negative edge of SCLK, and data is clocked into the device on the positive edge of SCLK.

#### SPI Command Word

All data transactions on the SPI bus begin with the master taking  $\overline{CS}$  from high to low and sending out the command word. This indicates to the AD7142 whether the transaction is a read or a write, and gives the address of the register from which to begin the data transfer. The following bit map shows the SPI command word.

MSB						LSB
15	14	13	12	11	10	9:0
1	1	1	0	0	R/W	Register address

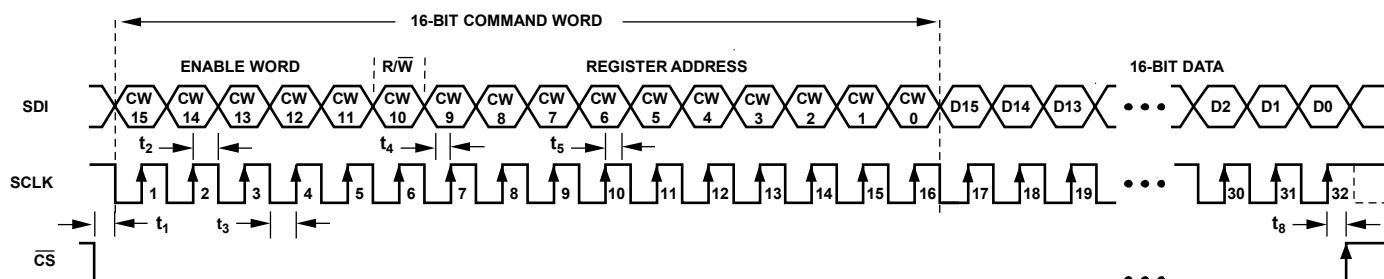

#### NOTES

- SDI BITS ARE LATCHED ON SCLK RISING EDGES. SCLK CAN IDLE HIGH OR LOW BETWEEN WRITE OPERATIONS.
- ALL 32 BITS MUST BE WRITTEN: 16 BITS FOR CONTROL WORD AND 16 BITS FOR DATA.
- 16-BIT COMMAND WORD SETTINGS FOR SERIAL WRITE OPERATION:  
 CW[15:11] = 11100 (ENABLE WORD)  
 CW[10] = 0 (R/W)  
 CW[9:0] = [AD9, AD8, AD7, AD6, AD5, AD4, AD3, AD2, AD1, AD0] (10-BIT MSB JUSTIFIED REGISTER ADDRESS)

Figure 46. Single Register Write SPI Timing

Bits[15:11] of the command word must be set to 11100 to successfully begin a bus transaction.

Bit 10 is the read/write bit; 1 indicates a read, and 0 indicates a write.

Bits[9:0] contain the target register address. When reading or writing to more than one register, this address indicates the address of the first register to be written to or read from.

#### Writing Data

Data is written to the AD7142 in 16-bit words. The first word written to the device is the command word, with the read/write bit set to 0. The master then supplies the 16-bit input data-word on the SDI line. The AD7142 clocks the data into the register addressed in the command word. If there is more than one word of data to be clocked in, the AD7142 automatically increments the address pointer, and clocks the next data-word into the next register.

The AD7142 continues to clock in data on the SDI line until either the master finishes the write transition by pulling  $\overline{CS}$  high, or the address pointer reaches its maximum value. The AD7142 address pointer does not wrap around. When it reaches its maximum value, any data provided by the master on the SDI line is ignored by the AD7142.



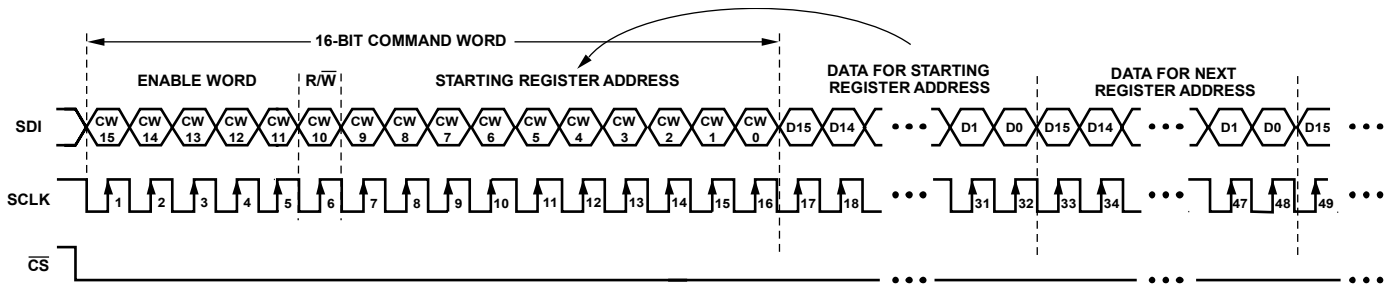

**NOTES**

1. MULTIPLE SEQUENTIAL REGISTERS CAN BE LOADED CONTINUOUSLY.
2. THE FIRST (LOWEST ADDRESS) REGISTER ADDRESS IS WRITTEN, FOLLOWED BY MULTIPLE 16-BIT DATA-WORDS.
3. THE ADDRESS AUTOMATICALLY INCREMENTS WITH EACH 16-BIT DATA-WORD (ALL 16 BITS MUST BE WRITTEN).
4. CS IS HELD LOW UNTIL THE LAST DESIRED REGISTER HAS BEEN LOADED.
5. 16-BIT COMMAND WORD SETTINGS FOR SEQUENTIAL WRITE OPERATION:  
 CW[15:11] = 11100 (ENABLE WORD)  
 CW[10] = 0 (R/W)  
 CW[9:0] = [AD9, AD8, AD7, AD6, AD5, AD4, AD3, AD2, AD1, AD0] (STARTING MSB JUSTIFIED REGISTER ADDRESS)

Figure 47. Sequential Register Write SPI Timing

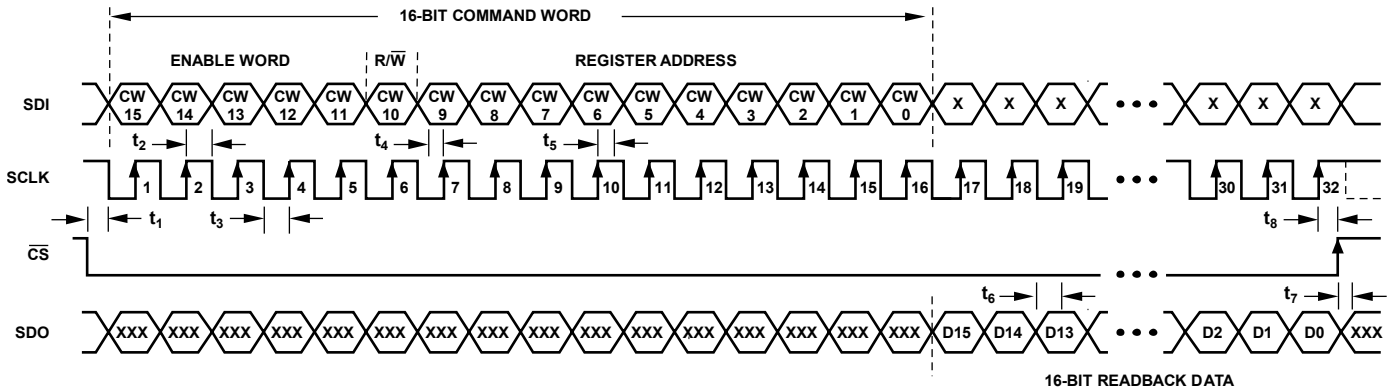

**NOTES**

1. SDI BITS ARE LATCHED ON SCLK RISING EDGES. SCLK CAN IDLE HIGH OR LOW BETWEEN WRITE OPERATIONS.
2. THE 16-BIT CONTROL WORD MUST BE WRITTEN ON SDI: 5 BITS FOR ENABLE WORD, 1 BIT FOR R/W, AND 10 BITS FOR REGISTER ADDRESS.
3. THE REGISTER DATA IS READ BACK ON THE SDO PIN.
4. X DENOTES DON'T CARE.
5. XXX DENOTES HIGH IMPEDANCE THREE-STATE OUTPUT.
6. CS IS HELD LOW UNTIL ALL REGISTER BITS HAVE BEEN READ BACK.
7. 16-BIT COMMAND WORD SETTINGS FOR SINGLE READBACK OPERATION:  
 CW[15:11] = 11100 (ENABLE WORD)  
 CW[10] = 1 (R/W)  
 CW[9:0] = [AD9, AD8, AD7, AD6, AD5, AD4, AD3, AD2, AD1, AD0] (10-BIT MSB JUSTIFIED REGISTER ADDRESS)

Figure 48. Single Register Readback SPI Timing

## Reading Data

A read transaction begins when the master writes the command word to the AD7142 with the read/write bit set to 1. The master then supplies 16 clock pulses per data-word to be read, and the AD7142 clocks out data from the addressed register on the SDO line. The first data-word is clocked out on the first falling edge of SCLK following the command word, as shown in Figure 48.

The AD7142 continues to clock out data on the SDO line provided the master continues to supply the clock signal on SCLK. The read transaction finishes when the master takes CS high. If the AD7142 address pointer reaches its maximum value, then the AD7142 repeatedly clocks out data from the addressed register. The address pointer does not wrap around.

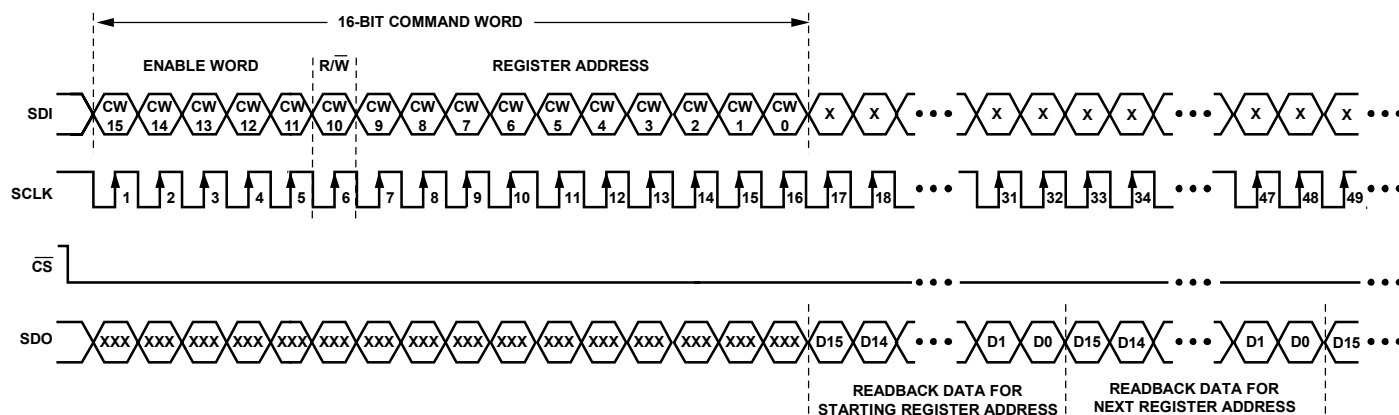

## NOTES

- MULTIPLE REGISTERS CAN BE READ BACK CONTINUOUSLY.
- THE 16-BIT CONTROL WORD MUST BE WRITTEN ON SDI: 5 BITS FOR ENABLE WORD, 1 BIT FOR  $\overline{R/W}$ , AND 10 BITS FOR REGISTER ADDRESS.
- THE ADDRESS AUTOMATICALLY INCREMENTS WITH EACH 16-BIT DATA-WORD BEING READ BACK ON THE SDO PIN.
- CS IS HELD LOW UNTIL ALL REGISTER BITS HAVE BEEN READ BACK.
- X DENOTES DON'T CARE.
- XXX DENOTES HIGH IMPEDANCE THREE-STATE OUTPUT.
- 16-BIT COMMAND WORD SETTINGS FOR SEQUENTIAL READBACK OPERATION:  
 CW[15:11] = 11100 (ENABLE WORD)  
 CW[10] = 1 ( $\overline{R/W}$ )  
 CW[9:0] = [AD9, AD8, AD7, AD6, AD5, AD4, AD3, AD2, AD1, AD0] (STARTING MSB JUSTIFIED REGISTER ADDRESS)

Figure 49. Sequential Register Read back SPI Timing

## I<sup>2</sup>C COMPATIBLE INTERFACE

The AD7142-1 supports the industry standard 2-wire I<sup>2</sup>C serial interface protocol. The two wires associated with the I<sup>2</sup>C timing are the SCLK and the SDA inputs. The SDA is an I/O pin that allows both register write and register readback operations. The AD7142-1 is always a slave device on the I<sup>2</sup>C serial interface bus.

It has a 7-bit device address, Address 0101 1XX. The lower two bits are set by tying the ADD0 and ADD1 pins high or low. The AD7142-1 responds when the master device sends its device address over the bus. The AD7142-1 cannot initiate data transfers on the bus.

Table 17. AD7142-1 I<sup>2</sup>C Device Address

ADD1	ADD0	I <sup>2</sup> C Address
0	0	0101 100
0	1	0101 101
1	0	0101 110
1	1	0101 111

### Data Transfer

Data is transferred over the I<sup>2</sup>C serial interface in 8-bit bytes. The master initiates a data transfer by establishing a start condition, defined as a high-to-low transition on the serial data line, SDA, when the serial clock line, SCLK, remains high. This indicates that an address/data stream follows.

All slave peripherals connected to the serial bus respond to the start condition and shift in the next eight bits, consisting of a 7-bit address (MSB first) plus a  $\overline{R/W}$  bit that determines the direction of the data transfer. The peripheral whose address corresponds to the transmitted address responds by pulling the data line low during the ninth clock pulse. This is known as the acknowledge bit. All other devices on the bus now remain idle when the selected device waits for data to be read from, or written to it. If the  $\overline{R/W}$  bit is a 0, the master writes to the slave device. If the  $\overline{R/W}$  bit is a 1, the master reads from the slave device.

Data is sent over the serial bus in a sequence of nine clock pulses, eight bits of data followed by an acknowledge bit from the slave device. Transitions on the data line must occur during the low period of the clock signal and remain stable during the high period, since a low-to-high transition when the clock is high can be interpreted as a stop signal. The number of data bytes transmitted over the serial bus in a single read or write operation is limited only by what the master and slave devices can handle.

When all data bytes are read or written, a stop condition is established. A stop condition is defined by a low-to-high transition on SDA when SCLK remains high. If the AD7142 encounters a stop condition, it returns to its idle condition, and the address pointer register resets to Address 0x00.

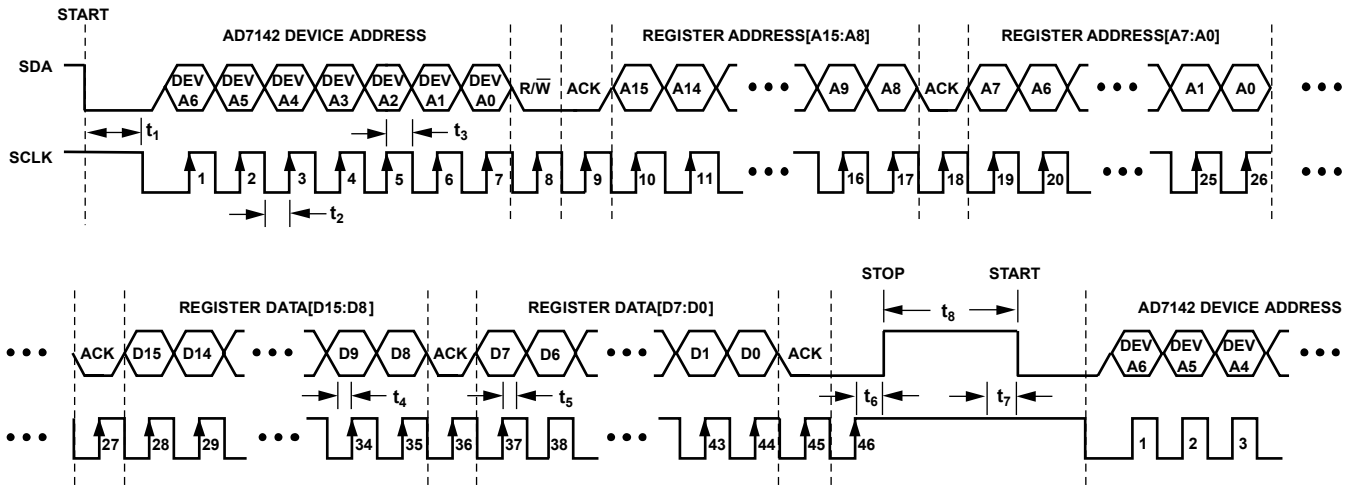

- NOTES**
1. A START CONDITION AT THE BEGINNING IS DEFINED AS A HIGH-TO-LOW TRANSITION ON SDA WHILE SCLK REMAINS HIGH.
  2. A STOP CONDITION AT THE END IS DEFINED AS A LOW-TO-HIGH TRANSITION ON SDA WHILE SCLK REMAINS HIGH.
  3. 7-BIT DEVICE ADDRESS [DEV A6:DEV A0] = [0 1 0 1 1 X X], WHERE X ARE DON'T CARE BITS.
  4. 16-BIT REGISTER ADDRESS[A15:A0] = [X, X, X, X, X, X, X, A9, A8, A7, A6, A5, A4, A3, A2, A1, A0], WHERE X ARE DON'T CARE BITS.
  5. REGISTER ADDRESS [A15:A8] AND REGISTER ADDRESS [A7:A0] ARE ALWAYS SEPARATED BY A LOW ACK BIT.
  6. REGISTER DATA [D15:D8] AND REGISTER DATA [D7:D0] ARE ALWAYS SEPARATED BY A LOW ACK BIT.

Figure 50. Example of I<sup>2</sup>C Timing for Single Register Write Operation

## Writing Data over the I<sup>2</sup>C Bus

The process for writing to the AD7142-1 over the I<sup>2</sup>C bus is shown in Figure 50 and Figure 52. The device address is sent over the bus followed by the R/W bit set to 0. This is followed by two bytes of data that contain the 10-bit address of the internal data register to be written. The following bit map shows the upper register address bytes. Note that Bit 7 to Bit 2 in the upper address byte are don't care bits. The address is contained in the 10 LSBs of the register address bytes.

MSB						LSB	
7	6	5	4	3	2	1	0
X	X	X	X	X	X	Register Address Bit 9	Register Address Bit 8

The following bit map shows the lower register address bytes.

MSB						LSB	
7	6	5	4	3	2	1	0
Reg. Addr. Bit 7	Reg. Addr. Bit 6	Reg. Addr. Bit 5	Reg. Addr. Bit 4	Reg. Addr. Bit 3	Reg. Addr. Bit 2	Reg. Addr. Bit 1	Reg. Addr. Bit 0

The third data byte contains the 8 MSBs of the data to be written to the internal register. The fourth data byte contains the 8 LSBs of data to be written to the internal register.

The AD7142-1 address pointer register automatically increments after each write. This allows the master to sequentially write to all registers on the AD7142-1 in the same write transaction. However, the address pointer register does not wrap around after the last address.

Any data written to the AD7142-1 after the address pointer has reached its maximum value is discarded.

All registers on the AD7142-1 are 16-bit. Two consecutive 8-bit data bytes are combined and written to the 16-bit registers. To avoid errors, all writes to the device must contain an even number of data bytes.

To finish the transaction, the master generates a stop condition on SDO, or generates a repeat start condition if the master is to maintain control of the bus.

## Reading Data over the I<sup>2</sup>C Bus

To read from the AD7142-1, the address pointer register must first be set to the address of the required internal register. The master performs a write transaction, and writes to the AD7142-1 to set the address pointer. The master then outputs a repeat start condition to keep control of the bus, or if this is not possible, ends the write transaction with a stop condition. A read transaction is initiated, with the R/W bit set to 1.

The AD7142-1 supplies the upper eight bits of data from the addressed register in the first readback byte, followed by the lower eight bits in the next byte. This is shown in Figure 51 and Figure 52.

Because the address pointer automatically increases after each read, the AD7142-1 continues to output readback data until the master puts a no acknowledge and stop condition on the bus. If the address pointer reaches its maximum value, and the master continues to read from the part, the AD7142-1 repeatedly sends data from the last register addressed.

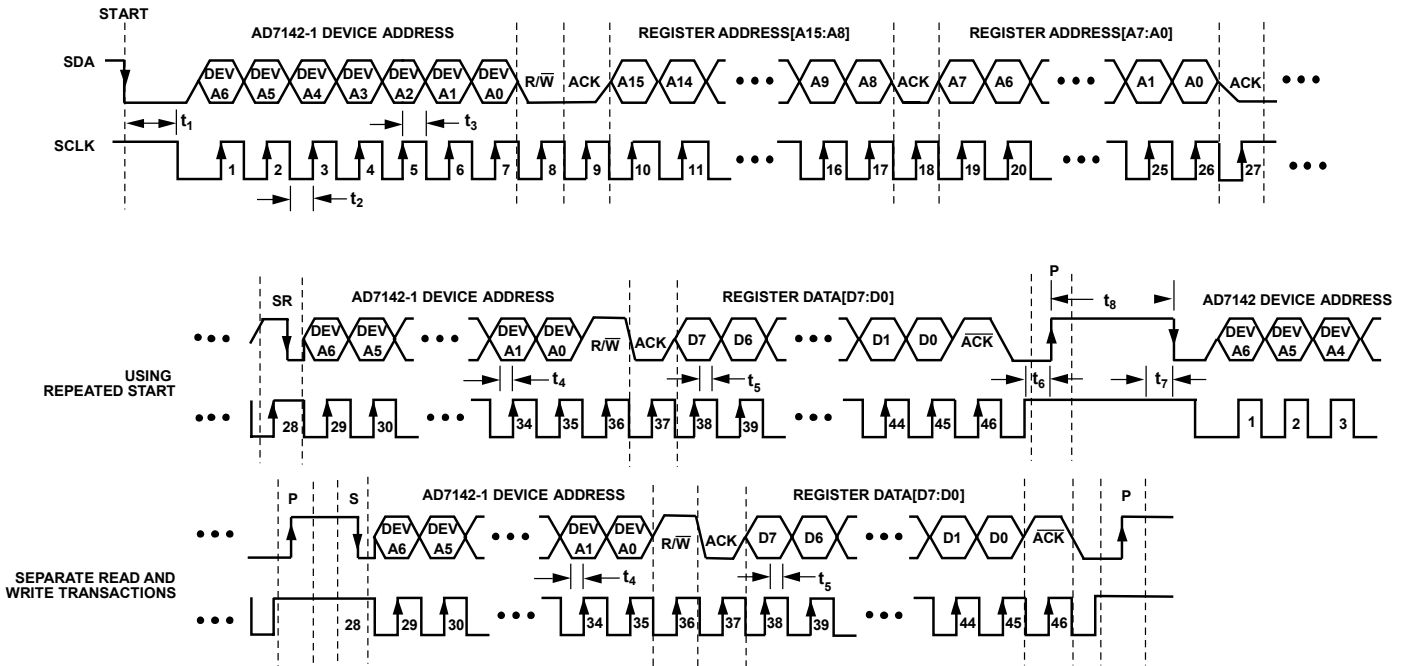

NOTES

1. A START CONDITION AT THE BEGINNING IS DEFINED AS A HIGH-TO-LOW TRANSITION ON SDA WHILE SCLK REMAINS HIGH.
2. A STOP CONDITION AT THE END IS DEFINED AS A LOW-TO-HIGH TRANSITION ON SDA WHILE SCLK REMAINS HIGH.
3. THE MASTER GENERATES THE ACK AT THE END OF THE READBACK TO SIGNAL THAT IT DOES NOT WANT ADDITIONAL DATA.
4. 7-BIT DEVICE ADDRESS [DEV A6:DEV A0] = [0 1 0 1 1 X X], WHERE THE TWO LSB X'S ARE DON'T CARE BITS.
5. 16-BIT REGISTER ADDRESS[A15:A0] = [X, X, X, X, X, X, A9, A8, A7, A6, A5, A4, A3, A2, A1, A0], WHERE THE UPPER LSB X'S ARE DON'T CARE BITS.
6. REGISTER ADDRESS [A15:A8] AND REGISTER ADDRESS [A7:A0] ARE ALWAYS SEPARATED BY A LOW ACK BITS.
7. REGISTER DATA [D15:D8] AND REGISTER DATA [D7:D0] ARE ALWAYS SEPARATED BY A LOW ACK BIT.
8. THE R/W BIT IS SET TO A1 TO INDICATE A READBACK OPERATION.

Figure 51. Example of I<sup>2</sup>C Timing for Single Register Readback Operation

WRITE



READ (USING REPEATED START)



READ (WRITE TRANSACTION SETS UP REGISTER ADDRESS)

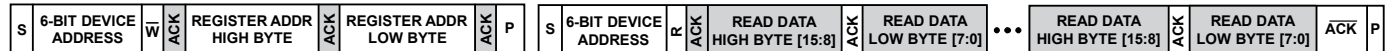

- OUTPUT FROM MASTER
- OUTPUT FROM AD7142
- S = START BIT
- P = STOP BIT
- SR = REPEATED START BIT
- ACK = ACKNOWLEDGE BIT
- ACK = NO ACKNOWLEDGE BIT

Figure 52. Example of Sequential I<sup>2</sup>C Write and Readback Operation

V<sub>DRIVE</sub> INPUT

The supply voltage to all pins associated with both the I<sup>2</sup>C and SPI serial interfaces (SDO, SDI, SCLK, SDA, and CS) is separate from the main V<sub>CC</sub> supplies and is connected to the V<sub>DRIVE</sub> pin.

This allows the AD7142 to be connected directly to processors whose supply voltage is less than the minimum operating voltage of the AD7142 without the need for external level-shifters. The V<sub>DRIVE</sub> pin can be connected to voltage supplies as low as 1.65 V and as high as DV<sub>CC</sub>.

# PCB DESIGN GUIDELINES

## CAPACITIVE SENSOR BOARD MECHANICAL SPECIFICATIONS

Table 18.

Parameter	Symbol	Min	Typ	Max	Unit
Distance from Edge of Any Sensor to Edge of Grounded Metal Object	D <sub>1</sub>	0.1			mm
Distance Between Sensor Edges <sup>1</sup>	D <sub>2</sub> = D <sub>3</sub> = D <sub>4</sub>	0			mm
Distance Between Bottom of Sensor Board and Controller Board or Grounded Metal Casing <sup>2</sup>	D <sub>5</sub>		1.0		mm

<sup>1</sup> The distance is dependent on the application and the positioning of the switches relative to each other and with respect to the user's finger positioning and handling. Adjacent sensors, with 0 minimum space between them, are implemented differentially.

<sup>2</sup> The 1.0 mm specification is meant to prevent direct sensor board contact with any conductive material. This specification does not guarantee no EMI coupling from the controller board to the sensors. Address potential EMI coupling issues by placing a grounded metal shield between the capacitive sensor board and the main controller board as shown in Figure 55.

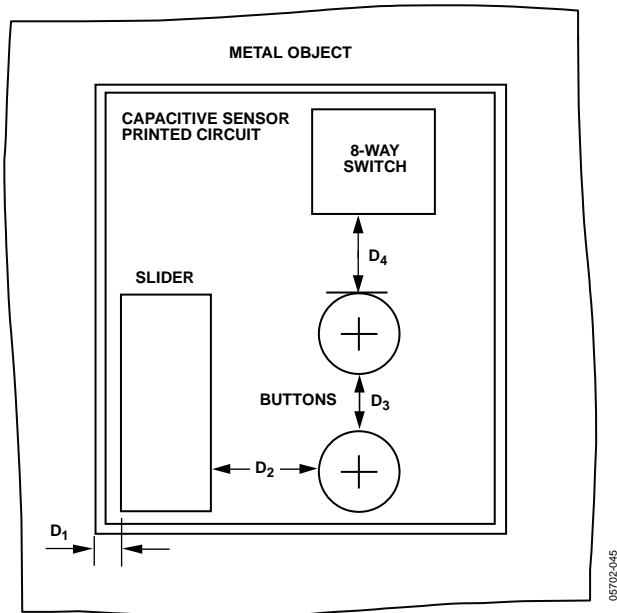

Figure 53. Capacitive Sensor Board Mechanicals Top View

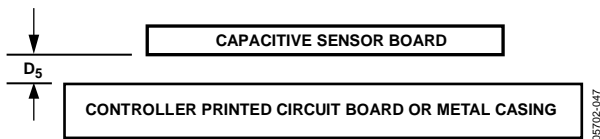

Figure 54. Capacitive Sensor Board Mechanicals Side View

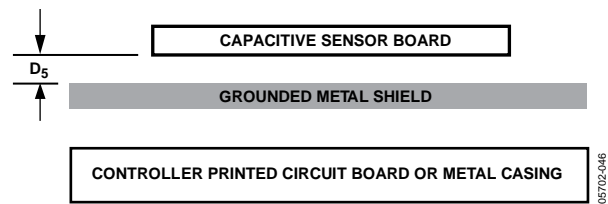

Figure 55. Capacitive Sensor Board with Grounded Shield

### CHIP SCALE PACKAGES

The lands on the chip scale package (CP-32-3) are rectangular. The printed circuit board pad for these should be 0.1 mm longer than the package land length, and 0.05 mm wider than the package land width. Center the land on the pad to maximize the solder joint size.

The bottom of the chip scale package has a central thermal pad. The thermal pad on the printed circuit board should be at least as large as this exposed pad. To avoid shorting, provide a clearance of at least 0.25 mm between the thermal pad and the inner edges of the land pattern on the printed circuit board.

Thermal vias can be used on the printed circuit board thermal pad to improve thermal performance of the package. If vias are used, they should be incorporated in the thermal pad at a 1.2 mm pitch grid. The via diameter should be between 0.3 mm and 0.33 mm, and the via barrel should be plated with 1 oz. copper to plug the via.

Connect the printed circuit board thermal pad to GND.

## POWER-UP SEQUENCE

When the AD7142 is powered up, the following sequence is recommended when initially developing the AD7142 and  $\mu$ P serial interface:

1. Turn on the power supplies to the AD7142.
2. Write to the Bank 2 registers at Address 0x080 through Address 0x0DF. These registers are contiguous so a sequential register write sequence can be applied.  
Note: The Bank 2 register values are unique for each application. Register values are provided by Analog Devices after the sensor board has been developed.
3. Write to the Bank 1 registers at Address 0x000 through Address 0x007 as follows. These registers are contiguous so a sequential register write sequence can be applied (see Figure 47 and Figure 52).

Caution: At this time, Address 0x001 must remain set to default value 0x0000 during this contiguous write operation.

Register values:

Address 0x000 = 0x00B2

Address 0x001 = 0x0000

Address 0x002 = 0x3230

Address 0x003 = 0x14C8

Address 0x004 = 0x0832

Address 0x005 = 0x0000

Address 0x006 = 0x0000

Address 0x007 = 0x0001 (The AD7142 interrupt is asserted approximately every 36 ms.)

4. Write to the Bank 1 register, Address 0x001 = 0x0FFF.
5. Read back the corresponding interrupt status register at Address 0x008, Address 0x009, or Address 0x00A. This is determined by the interrupt output configuration as explained in the Interrupt Output section.

Note: The specific registers required to be read back depend on each application. Analog Devices provides this information after the sensor board has been developed.

6. Repeat Step 5 every time  $\overline{\text{INT}}$  is asserted.

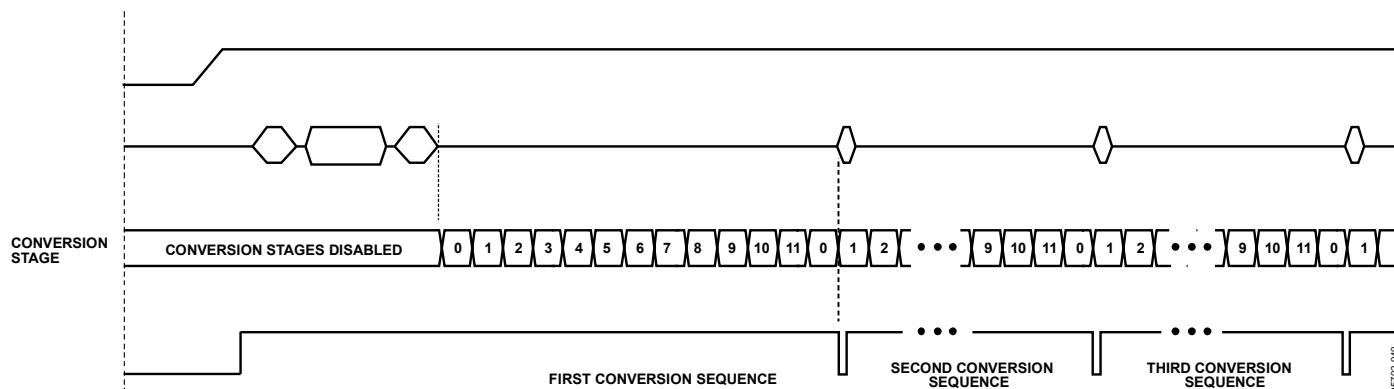

Figure 56. Recommended Start-Up Sequence

TYPICAL APPLICATION CIRCUITS

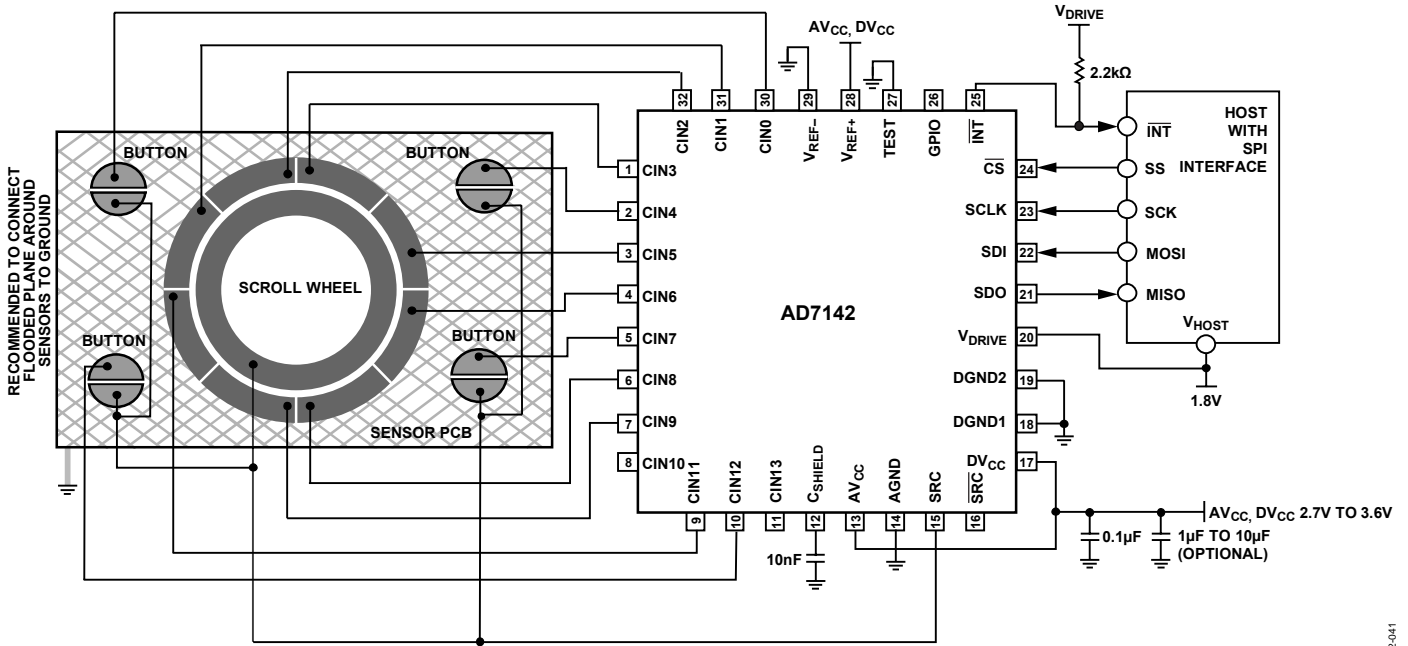

Figure 57. Typical Application Circuit with SPI Interface

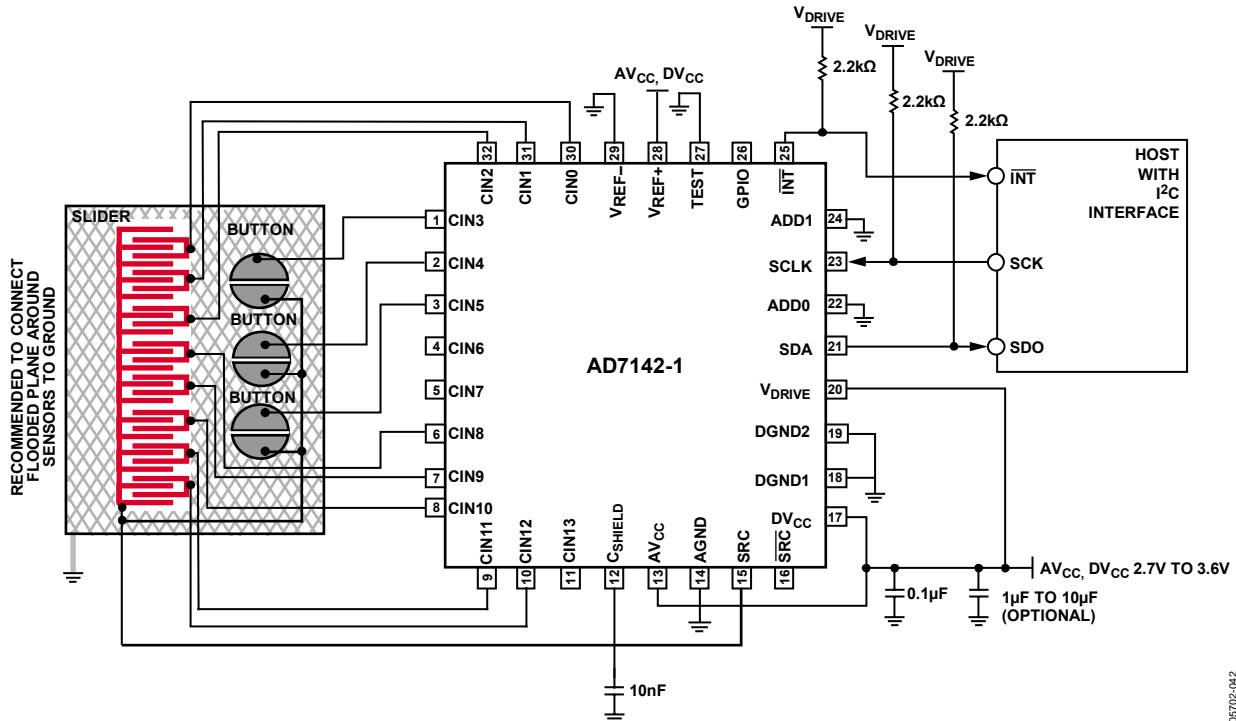

Figure 58. Typical Application Circuit with I<sup>2</sup>C Interface

## REGISTER MAP

The AD7142 address space is divided into three different register banks, referred to as Bank 1, Bank 2, and Bank 3. Figure 59 shows the division of these three banks.

Bank 1 contains control registers, CDC conversion control registers, interrupt enable registers, interrupt status registers, CDC 16-bit conversion data registers, device ID registers, and proximity status registers.

Bank 2 contains the configuration registers used for uniquely configuring the CIN inputs for each conversion stage. Initialize the Bank 2 configuration registers immediately after power-up to obtain valid CDC conversion result data.

Bank 3 registers contain the results of each conversion stage. These registers automatically update at the end of each conversion sequence. Although these registers are primarily used by the AD7142 internal data processing, they are accessible by the host processor for additional external data processing, if desired.

Default values are undefined for Bank 2 registers and Bank 3 registers until after power-up and configuration of the Bank 2 registers.

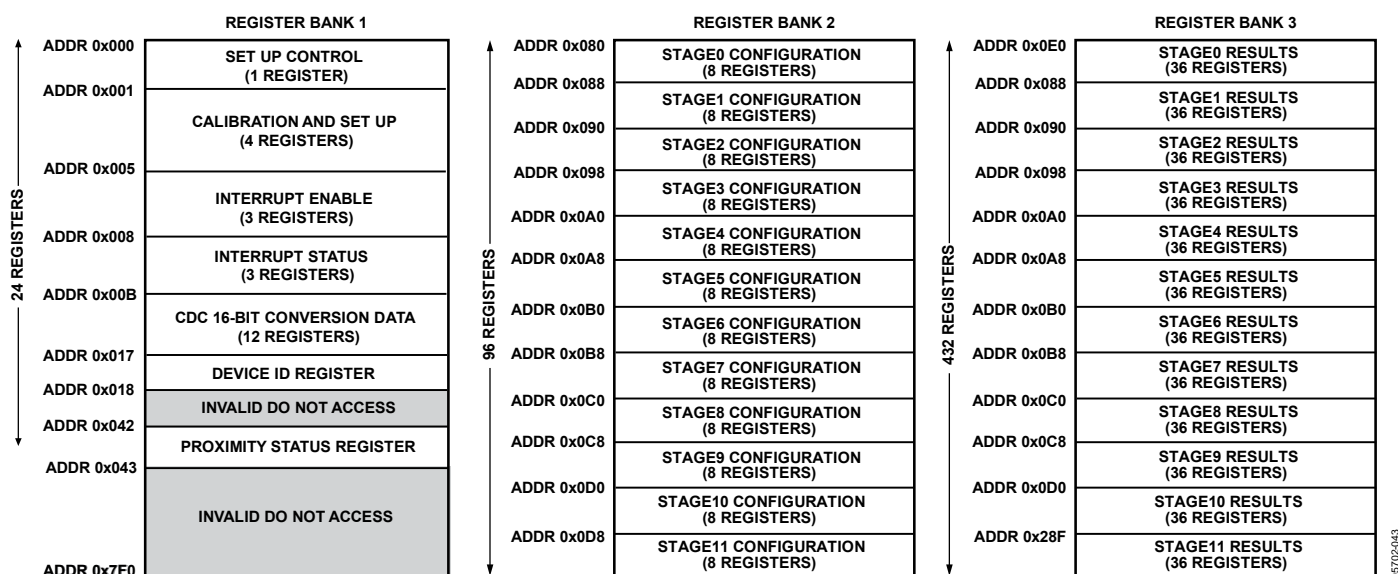

Figure 59. Layout of Bank 1 Registers, Bank 2 Registers, and Bank 3 Registers

057020-043



## DETAILED REGISTER DESCRIPTIONS

### BANK 1 REGISTERS

All addresses and default values are expressed in hexadecimal.

Table 19. PWR\_CONTROL Register

Address	Data Bit	Default Value	Type	Name	Description
0x000	[1:0]	0	R/W	POWER_MODE	Operating modes 00 = full power mode (normal operation, CDC conversions approximately every 36 ms) 01 = full shutdown mode (no CDC conversions) 10 = low power mode (automatic wake up operation) 11 = full shutdown mode (no CDC conversions)
	[3:2]	0		LP_CONV_DELAY	Low power mode conversion delay 00 = 200 ms 01 = 400 ms 10 = 600 ms 11 = 800 ms
	[7:4]	0		SEQUENCE_STAGE_NUM	Number of stages in sequence (N + 1) 0000 = 1 conversion stage in sequence 0001 = 2 conversion stages in sequence  Maximum value = 1011 = 12 conversion stages per sequence
	[9:8]	0		DECIMATION	ADC decimation factor 00 = decimate by 256 01 = decimate by 128 10 = do not use this setting 11 = do not use this setting
	[10]	0		SW_RESET	Software reset control (self-clearing) 1 = resets all registers to default values
	[11]	0		INT_POL	Interrupt polarity control 0 = active low 1 = active high
	[12]	0		EXCITATION_SOURCE	Excitation source control for Pin 15 0 = enable output 1 = disable output
	[13]	0		$\overline{\text{SRC}}$	Excitation source control for Pin 16 0 = enable output 1 = disable output
	[15:14]	0		CDC_BIAS	CDC bias current control 00 = normal operation 01 = normal operation + 20% 10 = normal operation + 35% 11 = normal operation + 50%

Table 20. STAGE\_CAL\_EN Register

Address	Data Bit	Default Value	Type	Name	Description
0x001	[0]	0	R/W	STAGE0_CAL_EN	STAGE0 calibration enable 0 = disable 1 = enable
	[1]	0		STAGE1_CAL_EN	STAGE1 calibration enable 0 = disable 1 = enable
	[2]	0		STAGE2_CAL_EN	STAGE2 calibration enable 0 = disable 1 = enable
	[3]	0		STAGE3_CAL_EN	STAGE3 calibration enable 0 = disable 1 = enable
	[4]	0		STAGE4_CAL_EN	STAGE4 calibration enable 0 = disable 1 = enable
	[5]	0		STAGE5_CAL_EN	STAGE5 calibration enable 0 = disable 1 = enable
	[6]	0		STAGE6_CAL_EN	STAGE6 calibration enable 0 = disable 1 = enable
	[7]	0		STAGE7_CAL_EN	STAGE7 calibration enable 0 = disable 1 = enable
	[8]	0		STAGE8_CAL_EN	STAGE8 calibration enable 0 = disable 1 = enable
	[9]	0		STAGE9_CAL_EN	STAGE9 calibration enable 0 = disable 1 = enable
	[10]	0		STAGE10_CAL_EN	STAGE10 calibration enable 0 = disable 1 = enable
	[11]	0		STAGE11_CAL_EN	STAGE11 calibration enable 0 = disable 1 = enable
	[13:12]	0		AVG_FP_SKIP	Full power mode skip control 00 = skip 3 samples 01 = skip 7 samples 10 = skip 15 samples 11 = skip 31 samples
	[15:14]	0		AVG_LP_SKIP	Low power mode skip control 00 = use all samples 01 = skip 1 sample 10 = skip 2 samples 11 = skip 3 samples

**Table 21. AMB\_COMP\_CTRL0 Register**

Address	Data Bit	Default Value	Type	Name	Description
0x002	[3:0]	0	R/W	FF_SKIP_CNT	Fast filter skip control (N+1) 0000 = no sequence of results are skipped 0001 = one sequence of results is skipped for every one allowed into fast FIFO 0010 = two sequences of results are skipped for every one allowed into fast FIFO 1011 = maximum value = 12 sequences of results are skipped for every one allowed into Fast FIFO
	[7:4]	F		FP_PROXIMITY_CNT	Calibration disable period in full power mode = FP_PROXIMITY_CNT × 16 × Time taken for one conversion sequence in full power mode
	[11:8]	F		LP_PROXIMITY_CNT	Calibration disable period in low power mode = LP_PROXIMITY_CNT × 4 × Time taken for one conversion sequence in low power mode
	[13:12]	0		PWR_DOWN_TIMEOUT	Full power to low power mode timeout control 00 = 1.25 × (FP_PROXIMITY_CNT) 01 = 1.50 × (FP_PROXIMITY_CNT) 10 = 1.75 × (FP_PROXIMITY_CNT) 11 = 2.00 × (FP_PROXIMITY_CNT)
	[14]	0		FORCED_CAL	Forced calibration control 0 = normal operation 1 = forces all conversion stages to recalibrate
	[15]	0		CONV_RESET	Conversion reset control (self-clearing) 0 = normal operation 1 = resets the conversion sequence back to STAGE0

**Table 22. AMB\_COMP\_CTRL1 Register**

Address	Data Bit	Default Value	Type	Name	Description
0x003	[7:0]	64	R/W	PROXIMITY_RECAL_LVL	Proximity recalibration level
	[13:8]	1		PROXIMITY_DETECTION_RATE	Proximity detection rate
	[15:14]	0		SLOW_FILTER_UPDATE_LVL	Slow filter update level

**Table 23. AMB\_COMP\_CTRL2 Register**

Address	Data Bit	Default Value	Type	Name	Description
0x004	[9:0]	3FF	R/W	FP_PROXIMITY_RECAL	Full power mode proximity recalibration time control
	[15:10]	3F		LP_PROXIMITY_RECAL	Low power mode proximity recalibration time control

Table 24. STAGE\_LOW\_INT\_EN Register

Address	Data Bit	Default Value	Type	Name	Description
0x005	[0]	0	R/W	STAGE0_LOW_INT_EN	STAGE0 low interrupt enable 0 = interrupt source disabled 1 = $\overline{\text{INT}}$ asserted if STAGE0 low threshold is exceeded
	[1]	0		STAGE1_LOW_INT_EN	STAGE1 low interrupt enable 0 = interrupt source disabled 1 = $\overline{\text{INT}}$ asserted if STAGE1 low threshold is exceeded
	[2]	0		STAGE2_LOW_INT_EN	STAGE2 low interrupt enable 0 = interrupt source disabled 1 = $\overline{\text{INT}}$ asserted if STAGE2 low threshold is exceeded
	[3]	0		STAGE3_LOW_INT_EN	STAGE3 low interrupt enable 0 = interrupt source disabled 1 = $\overline{\text{INT}}$ asserted if STAGE3 low threshold is exceeded
	[4]	0		STAGE4_LOW_INT_EN	STAGE4 low interrupt enable 0 = interrupt source disabled 1 = $\overline{\text{INT}}$ asserted if STAGE4 low threshold is exceeded
	[5]	0		STAGE5_LOW_INT_EN	STAGE5 low interrupt enable 0 = interrupt source disabled 1 = $\overline{\text{INT}}$ asserted if STAGE5 low threshold is exceeded
	[6]	0		STAGE6_LOW_INT_EN	STAGE6 low interrupt enable 0 = interrupt source disabled 1 = $\overline{\text{INT}}$ asserted if STAGE6 low threshold is exceeded
	[7]	0		STAGE7_LOW_INT_EN	STAGE7 low interrupt enable 0 = interrupt source disabled 1 = $\overline{\text{INT}}$ asserted if STAGE7 low threshold is exceeded
	[8]	0		STAGE8_LOW_INT_EN	STAGE8 low interrupt enable 0 = interrupt source disabled 1 = $\overline{\text{INT}}$ asserted if STAGE8 low threshold is exceeded
	[9]	0		STAGE9_LOW_INT_EN	STAGE9 low interrupt enable 0 = interrupt source disabled 1 = $\overline{\text{INT}}$ asserted if STAGE9 low threshold is exceeded
	[10]	0		STAGE10_LOW_INT_EN	STAGE10 low interrupt enable 0 = interrupt source disabled 1 = $\overline{\text{INT}}$ asserted if STAGE10 low threshold is exceeded
	[11]	0		STAGE11_LOW_INT_EN	STAGE11 low interrupt enable 0 = interrupt source disabled 1 = $\overline{\text{INT}}$ asserted if STAGE11 low threshold is exceeded
	[13:12]	0		GPIO_SETUP	GPIO setup 00 = disable GPIO pin 01 = configure GPIO as an input 10 = configure GPIO as an active low output 11 = configure GPIO as an active high output
	[15:14]	0		GPIO_INPUT_CONFIG	GPIO input configuration 00 = triggered on negative level 01 = triggered on positive edge 10 = triggered on negative edge 11 = triggered on positive level

Table 25. STAGE\_HIGH\_INT\_EN Register

Address	Data Bit	Default Value	Type	Name	Description
0x006	[0]	0	R/W	STAGE0_HIGH_INT_EN	STAGE0 high interrupt enable 0 = interrupt source disabled 1 = $\overline{\text{INT}}$ asserted if STAGE0 high threshold is exceeded
	[1]	0		STAGE1_HIGH_INT_EN	STAGE1 high interrupt enable 0 = interrupt source disabled 1 = $\overline{\text{INT}}$ asserted if STAGE1 high threshold is exceeded
	[2]	0		STAGE2_HIGH_INT_EN	STAGE2 high interrupt enable 0 = interrupt source disabled 1 = $\overline{\text{INT}}$ asserted if STAGE2 high threshold is exceeded
	[3]	0		STAGE3_HIGH_INT_EN	STAGE3 high interrupt enable 0 = interrupt source disabled 1 = $\overline{\text{INT}}$ asserted if STAGE3 high threshold is exceeded
	[4]	0		STAGE4_HIGH_INT_EN	STAGE4 high interrupt enable 0 = interrupt source disabled 1 = $\overline{\text{INT}}$ asserted if STAGE4 high threshold is exceeded
	[5]	0		STAGE5_HIGH_INT_EN	STAGE5 high interrupt enable 0 = interrupt source disabled 1 = $\overline{\text{INT}}$ asserted if STAGE5 high threshold is exceeded
	[6]	0		STAGE6_HIGH_INT_EN	STAGE6 high interrupt enable 0 = interrupt source disabled 1 = $\overline{\text{INT}}$ asserted if STAGE6 high threshold is exceeded
	[7]	0		STAGE7_HIGH_INT_EN	STAGE7 high interrupt enable 0 = interrupt source disabled 1 = $\overline{\text{INT}}$ asserted if STAGE7 high threshold is exceeded
	[8]	0		STAGE8_HIGH_INT_EN	STAGE8 high interrupt enable 0 = interrupt source disabled 1 = $\overline{\text{INT}}$ asserted if STAGE8 high threshold is exceeded
	[9]	0		STAGE9_HIGH_INT_EN	STAGE9 sensor high interrupt enable I 0 = interrupt source disabled 1 = $\overline{\text{INT}}$ asserted if STAGE9 high threshold is exceeded
	[10]	0		STAGE10_HIGH_INT_EN	STAGE10 high interrupt enable 0 = interrupt source disabled 1 = $\overline{\text{INT}}$ asserted if STAGE10 high threshold is exceeded
	[11]	0		STAGE11_HIGH_INT_EN	STAGE11 high interrupt enable 0 = interrupt source disabled 1 = $\overline{\text{INT}}$ asserted if STAGE11 high threshold is exceeded
	[15:12]			Unused	Set unused register bits = 0

Table 26. STAGE\_COMPLETE\_INT\_EN Register

Address	Data Bit	Default Value	Type	Name	Description
0x007	[0]	0	R/W	STAGE0_COMPLETE_EN	STAGE0 conversion interrupt control 0 = interrupt source disabled 1 = $\overline{\text{INT}}$ asserted at completion of STAGE0 conversion
	[1]	0		STAGE1_COMPLETE_EN	STAGE1 conversion interrupt control 0 = interrupt source disabled 1 = $\overline{\text{INT}}$ asserted at completion of STAGE1 conversion
	[2]	0		STAGE2_COMPLETE_EN	STAGE2 conversion interrupt control 0 = interrupt source disabled 1 = $\overline{\text{INT}}$ asserted at completion of STAGE2 conversion
	[3]	0		STAGE3_COMPLETE_EN	STAGE3 conversion interrupt control 0 = interrupt source disabled 1 = $\overline{\text{INT}}$ asserted at completion of STAGE3 conversion
	[4]	0		STAGE4_COMPLETE_EN	STAGE4 conversion interrupt control 0 = interrupt source disabled 1 = $\overline{\text{INT}}$ asserted at completion of STAGE4 conversion
	[5]	0		STAGE5_COMPLETE_EN	STAGE5 conversion interrupt control 0 = interrupt source disabled 1 = $\overline{\text{INT}}$ asserted at completion of STAGE5 conversion
	[6]	0		STAGE6_COMPLETE_EN	STAGE6 conversion interrupt control 0 = interrupt source disabled 1 = $\overline{\text{INT}}$ asserted at completion of STAGE6 conversion
	[7]	0		STAGE7_COMPLETE_EN	STAGE7 conversion interrupt control 0 = interrupt source disabled 1 = $\overline{\text{INT}}$ asserted at completion of STAGE7 conversion
	[8]	0		STAGE8_COMPLETE_EN	STAGE8 conversion complete interrupt control 0 = interrupt source disabled 1 = $\overline{\text{INT}}$ asserted at completion of STAGE8 conversion
	[9]	0		STAGE9_COMPLETE_EN	STAGE9 conversion interrupt control 0 = interrupt source disabled 1 = $\overline{\text{INT}}$ asserted at completion of STAGE9 conversion
	[10]	0		STAGE10_COMPLETE_EN	STAGE10 conversion interrupt control 0 = interrupt source disabled 1 = $\overline{\text{INT}}$ asserted at completion of STAGE10 conversion
	[11]	0		STAGE11_COMPLETE_EN	STAGE11 conversion interrupt control 0 = interrupt source disabled 1 = $\overline{\text{INT}}$ asserted at completion of STAGE11 conversion
	[12]	0		GPIO_INT_EN	Interrupt control when GPIO input pin changes level 0 = disabled 1 = enabled
	[15:13]			Unused	Set unused register bits = 0

**Table 27. STAGE\_LOW\_LIMIT\_INT Register<sup>1</sup>**

Address	Data Bit	Default Value	Type	Name	Description
0x008	[0]	0	R	STAGE0_LOW_LIMIT_INT	STAGE0 CDC conversion low limit interrupt result 1 = indicates STAGE0_LOW_THRESHOLD value was exceeded
	[1]	0		STAGE1_LOW_LIMIT_INT	STAGE1 CDC conversion low limit interrupt result 1 = indicates STAGE1_LOW_THRESHOLD value was exceeded
	[2]	0		STAGE2_LOW_LIMIT_INT	STAGE2 CDC conversion low limit interrupt result 1 = indicates STAGE2_LOW_THRESHOLD value was exceeded
	[3]	0		STAGE3_LOW_LIMIT_INT	STAGE3 CDC conversion low limit interrupt result 1 = indicates STAGE3_LOW_THRESHOLD value was exceeded
	[4]	0		STAGE4_LOW_LIMIT_INT	STAGE4 CDC conversion low limit interrupt result 1 = indicates STAGE4_LOW_THRESHOLD value was exceeded
	[5]	0		STAGE5_LOW_LIMIT_INT	STAGE5 CDC conversion low limit interrupt result 1 = indicates STAGE5_LOW_THRESHOLD value was exceeded
	[6]	0		STAGE6_LOW_LIMIT_INT	STAGE6 CDC conversion low limit interrupt result 1 = indicates STAGE6_LOW_THRESHOLD value was exceeded
	[7]	0		STAGE7_LOW_LIMIT_INT	STAGE7 CDC conversion low limit interrupt result 1 = indicates STAGE7_LOW_THRESHOLD value was exceeded
	[8]	0		STAGE8_LOW_LIMIT_INT	STAGE8 CDC conversion low limit interrupt result 1 = indicates STAGE8_LOW_THRESHOLD value was exceeded
	[9]	0		STAGE9_LOW_LIMIT_INT	STAGE9 CDC conversion low limit interrupt result 1 = indicates STAGE9_LOW_THRESHOLD value was exceeded
	[10]	0		STAGE10_LOW_LIMIT_INT	STAGE10 CDC Conversion Low Limit Interrupt result 1 = indicates STAGE10_LOW_THRESHOLD value was exceeded
	[11]	0		STAGE11_LOW_LIMIT_INT	STAGE11 CDC conversion low limit interrupt result 1 = indicates STAGE11_LOW_THRESHOLD value was exceeded
	[15:12]			Unused	Set unused register bits = 0

<sup>1</sup> Registers self-clear to 0 after readback, provided that the limits are not exceeded.

Table 28. STAGE\_HIGH\_LIMIT\_INT Register<sup>1</sup>

Address	Data Bit	Default Value	Type	Name	Description
0x009	[0]	0	R	STAGE0_HIGH_LIMIT_INT	STAGE0 CDC conversion high limit interrupt result 1 = indicates STAGE0_HIGH_THRESHOLD value was exceeded
	[1]	0		STAGE1_HIGH_LIMIT_INT	STAGE1 CDC conversion high limit interrupt result 1 = indicates STAGE1_HIGH_THRESHOLD value was exceeded
	[2]	0		STAGE2_HIGH_LIMIT_INT	Stage2 CDC conversion high limit interrupt result 1 = indicates STAGE2_HIGH_THRESHOLD value was exceeded
	[3]	0		STAGE3_HIGH_LIMIT_INT	STAGE3 CDC conversion high limit interrupt result 1 = indicates STAGE3_HIGH_THRESHOLD value was exceeded
	[4]	0		STAGE4_HIGH_LIMIT_INT	STAGE4 CDC conversion high limit interrupt result 1 = indicates STAGE4_HIGH_THRESHOLD value was exceeded
	[5]	0		STAGE5_HIGH_LIMIT_INT	STAGE5 CDC conversion high limit interrupt result 1 = indicates STAGE5_HIGH_THRESHOLD value was exceeded
	[6]	0		STAGE6_HIGH_LIMIT_INT	STAGE6 CDC conversion high limit interrupt result 1 = indicates STAGE6_HIGH_THRESHOLD value was exceeded
	[7]	0		STAGE7_HIGH_LIMIT_INT	STAGE7 CDC conversion high limit interrupt result 1 = indicates STAGE7_HIGH_THRESHOLD value was exceeded
	[8]	0		STAGE8_HIGH_LIMIT_INT	STAGE8 CDC conversion high limit interrupt result 1 = indicates STAGE8_HIGH_THRESHOLD value was exceeded
	[9]	0		STAGE9_HIGH_LIMIT_INT	STAGE9 CDC conversion high limit interrupt result 1 = indicates STAGE9_HIGH_THRESHOLD value was exceeded
	[10]	0		STAGE10_HIGH_LIMIT_INT	STAGE10 CDC conversion high limit interrupt result 1 = indicates STAGE10_HIGH_THRESHOLD value was exceeded
	[11]	0		STAGE11_HIGH_LIMIT_INT	STAGE11 CDC conversion high limit interrupt result 1 = indicates STAGE11_HIGH_THRESHOLD value was exceeded
	[15:12]			Unused	Set unused register bits = 0

<sup>1</sup> Registers self-clear to 0 after readback, provided that the limits are not exceeded.



Table 29. STAGE\_COMPLETE\_LIMIT\_INT Register<sup>1</sup>

Address	Data Bit	Default Value	Type	Name	Description
0x00A	[0]	0	R	STAGE0_COMPLETE_STATUS_INT	STAGE0 conversion complete register interrupt status 1 = indicates STAGE0 conversion completed
	[1]	0		STAGE1_COMPLETE_STATUS_INT	STAGE1 conversion complete register interrupt status 1 = indicates STAGE1 conversion completed
	[2]	0		STAGE2_COMPLETE_STATUS_INT	STAGE2 conversion complete register interrupt status 1 = indicates STAGE2 conversion completed
	[3]	0		STAGE3_COMPLETE_STATUS_INT	STAGE3 conversion complete register interrupt status 1 = indicates STAGE3 conversion completed
	[4]	0		STAGE4_COMPLETE_STATUS_INT	STAGE4 conversion complete register interrupt status 1 = indicates STAGE4 conversion completed
	[5]	0		STAGE5_COMPLETE_STATUS_INT	STAGE5 conversion complete register interrupt status 1 = indicates STAGE5 conversion completed
	[6]	0		STAGE6_COMPLETE_STATUS_INT	STAGE6 conversion complete register interrupt status 1 = indicates STAGE6 conversion completed
	[7]	0		STAGE7_COMPLETE_STATUS_INT	STAGE7 conversion complete register interrupt status 1 = indicates STAGE7 conversion completed
	[8]	0		STAGE8_COMPLETE_STATUS_INT	STAGE8 conversion complete register interrupt status 1 = indicates STAGE8 conversion completed
	[9]	0		STAGE9_COMPLETE_STATUS_INT	STAGE9 conversion complete register interrupt status 1 = indicates STAGE9 conversion completed
	[10]	0		STAGE10_COMPLETE_STATUS_INT	STAGE10 conversion complete register interrupt status 1 = indicates STAGE10 conversion completed
	[11]	0		STAGE11_COMPLETE_STATUS_INT	STAGE11 conversion complete register interrupt status 1 = indicates STAGE11 conversion completed
	[12]	0		GPIO_STATUS	GPIO input pin status 1 = indicates level on GPIO pin has changed
	[15:13]			Unused	Set unused register bits = 0

<sup>1</sup> Registers self-clear to 0 after readback, provided that the limits are not exceeded.

Table 30. CDC 16-Bit Conversion Data Registers

Address	Data Bit	Default Value	Type	Name	Description
0x00B	[15:0]	0	R	ADC_RESULT_S0	STAGE0 CDC 16-bit conversion data
0x00C	[15:0]	0	R	ADC_RESULT_S1	STAGE1 CDC 16-bit conversion data
0x00D	[15:0]	0	R	ADC_RESULT_S2	STAGE2 CDC 16-bit conversion data
0x00E	[15:0]	0	R	ADC_RESULT_S3	STAGE3 CDC 16-bit conversion data
0x00F	[15:0]	0	R	ADC_RESULT_S4	STAGE4 CDC 16-bit conversion data
0x010	[15:0]	0	R	ADC_RESULT_S5	STAGE5 CDC 16-bit conversion data
0x011	[15:0]	0	R	ADC_RESULT_S6	STAGE6 CDC 16-bit conversion data
0x012	[15:0]	0	R	ADC_RESULT_S7	STAGE7 CDC 16-bit conversion data
0x013	[15:0]	0	R	ADC_RESULT_S8	STAGE8 CDC 16-bit conversion data
0x014	[15:0]	0	R	ADC_RESULT_S9	STAGE9 CDC 16-bit conversion data
0x015	[15:0]	0	R	ADC_RESULT_S10	STAGE10 CDC 16-bit conversion data
0x016	[15:0]	0	R	ADC_RESULT_S11	STAGE11 CDC 16-bit conversion data

Table 31. Device ID Register

Address	Data Bit	Default Value	Type	Name	Description
0x017	[3:0]	2	R	REVISION_CODE	AD7142 revision code
	[15:4]	E62		DEVID	AD7142 device ID = 1110 0110 0010

Table 32. Proximity Status Register

Address	Data Bit	Default Value	Type	Name	Description
0x042	[0]	0	R	STAGE0_PROXIMITY_STATUS	STAGE0 proximity status register 1 = indicates proximity has been detected on STAGE0
	[1]	0	R	STAGE1_PROXIMITY_STATUS	STAGE1 proximity status register 1 = indicates proximity has been detected on STAGE1
	[2]	0	R	STAGE2_PROXIMITY_STATUS	STAGE2 proximity status register 1 = indicates proximity has been detected on STAGE2
	[3]	0	R	STAGE3_PROXIMITY_STATUS	STAGE3 proximity status register 1 = indicates proximity has been detected on STAGE3
	[4]	0	R	STAGE4_PROXIMITY_STATUS	STAGE4 proximity status register 1 = indicates proximity has been detected on STAGE4
	[5]	0	R	STAGE5_PROXIMITY_STATUS	STAGE5 proximity status register 1 = indicates proximity has been detected on STAGE5
	[6]	0	R	STAGE6_PROXIMITY_STATUS	STAGE6 proximity status register 1 = indicates proximity has been detected on STAGE6
	[7]	0	R	STAGE7_PROXIMITY_STATUS	STAGE7 proximity status register 1 = indicates proximity has been detected on STAGE7
	[8]	0	R	STAGE8_PROXIMITY_STATUS	STAGE8 proximity status register 1 = indicates proximity has been detected on STAGE8
	[9]	0	R	STAGE9_PROXIMITY_STATUS	STAGE9 proximity status register 1 = indicates proximity has been detected on STAGE9
	[10]	0	R	STAGE10_PROXIMITY_STATUS	STAGE10 proximity status register 1 = indicates proximity has been detected on STAGE10
	[11]	0	R	STAGE11_PROXIMITY_STATUS	STAGE11 proximity status register 1 = indicates proximity has been detected on STAGE11
	[15:0]			Unused	Set unused register bits = 0

# AD7142

## BANK 2 REGISTERS

All address values are expressed in hexadecimal.

Table 33. STAGE0 Configuration Registers

Address	Data Bit	Default Value	Type	Name	Description
0x080	[15:0]	X	R/W	STAGE0_CONNECTION[6:0]	STAGE0 CIN(6:0) connection setup (see Table 45)
0x081	[15:0]	X	R/W	STAGE0_CONNECTION[13:7]	STAGE0 CIN(13:7) connection setup (see Table 46)
0x082	[15:0]	X	R/W	STAGE0_AFE_OFFSET	STAGE0 AFE offset control (see Table 47)
0x083	[15:0]	X	R/W	STAGE0_SENSITIVITY	STAGE0 sensitivity control (see Table 48)
0x084	[15:0]	X	R/W	STAGE0_OFFSET_LOW	STAGE0 initial offset low value
0x085	[15:0]	X	R/W	STAGE0_OFFSET_HIGH	STAGE0 initial offset high value
0x086	[15:0]	X	R/W	STAGE0_OFFSET_HIGH_CLAMP	STAGE0 offset high clamp value
0x087	[15:0]	X	R/W	STAGE0_OFFSET_LOW_CLAMP	STAGE0 offset low clamp value

Table 34. STAGE1 Configuration Registers

Address	Data Bit	Default Value	Type	Name	Description
0x088	[15:0]	X	R/W	STAGE1_CONNECTION[6:0]	STAGE1 CIN(6:0) connection setup (see Table 45)
0x089	[15:0]	X	R/W	STAGE1_CONNECTION[13:7]	STAGE1 CIN(13:7) connection setup (see Table 46)
0x08A	[15:0]	X	R/W	STAGE1_AFE_OFFSET	STAGE1 AFE offset control (see Table 47)
0x08B	[15:0]	X	R/W	STAGE1_SENSITIVITY	STAGE1 sensitivity control (see Table 48)
0x08C	[15:0]	X	R/W	STAGE1_OFFSET_LOW	STAGE1 initial offset low value
0x08D	[15:0]	X	R/W	STAGE1_OFFSET_HIGH	STAGE1 initial offset high value
0x08E	[15:0]	X	R/W	STAGE1_OFFSET_HIGH_CLAMP	STAGE1 offset high clamp value
0x08F	[15:0]	X	R/W	STAGE1_OFFSET_LOW_CLAMP	STAGE1 offset low clamp value

Table 35. STAGE2 Configuration Registers

Address	Data Bit	Default Value	Type	Name	Description
0x090	[15:0]	X	R/W	STAGE2_CONNECTION[6:0]	STAGE2 CIN(6:0) connection setup (see Table 45)
0x091	[15:0]	X	R/W	STAGE2_CONNECTION[13:7]	STAGE2 CIN(13:7) connection setup (see Table 46)
0x092	[15:0]	X	R/W	STAGE2_AFE_OFFSET	STAGE2 AFE offset control (see Table 47)
0x093	[15:0]	X	R/W	STAGE2_SENSITIVITY	STAGE2 sensitivity control (see Table 48)
0x094	[15:0]	X	R/W	STAGE2_OFFSET_LOW	STAGE2 initial offset low value
0x095	[15:0]	X	R/W	STAGE2_OFFSET_HIGH	STAGE2 initial offset high value
0x096	[15:0]	X	R/W	STAGE2_OFFSET_HIGH_CLAMP	STAGE2 offset high clamp value
0x097	[15:0]	X	R/W	STAGE2_OFFSET_LOW_CLAMP	STAGE2 offset low clamp value

Table 36. STAGE3 Configuration Registers

Address	Data Bit	Default Value	Type	Name	Description
0x098	[15:0]	X	R/W	STAGE3_CONNECTION[6:0]	STAGE3 CIN(6:0) connection setup (see Table 45)
0x099	[15:0]	X	R/W	STAGE3_CONNECTION[13:7]	STAGE3 CIN(13:7) connection setup (see Table 46)
0x09A	[15:0]	X	R/W	STAGE3_AFE_OFFSET	STAGE3 AFE offset control (see Table 47)
0x09B	[15:0]	X	R/W	STAGE3_SENSITIVITY	STAGE3 sensitivity control (see Table 48)
0x09C	[15:0]	X	R/W	STAGE3_OFFSET_LOW	STAGE3 initial offset low value
0x09D	[15:0]	X	R/W	STAGE3_OFFSET_HIGH	STAGE3 initial offset high value
0x09E	[15:0]	X	R/W	STAGE3_OFFSET_HIGH_CLAMP	STAGE3 offset high clamp value
0x09F	[15:0]	X	R/W	STAGE3_OFFSET_LOW_CLAMP	STAGE3 offset low clamp value

Table 37. STAGE4 Configuration Registers

Address	Data Bit	Default Value	Type	Name	Description
0x0A0	[15:0]	X	R/W	STAGE4_CONNECTION[6:0]	STAGE4 CIN(6:0) connection setup (see Table 45)
0x0A1	[15:0]	X	R/W	STAGE4_CONNECTION[13:7]	STAGE4 CIN(13:7) connection setup (see Table 46)
0x0A2	[15:0]	X	R/W	STAGE4_AFE_OFFSET	STAGE4 AFE offset control (see Table 47)
0x0A3	[15:0]	X	R/W	STAGE4_SENSITIVITY	STAGE4 sensitivity control (see Table 48)
0x0A4	[15:0]	X	R/W	STAGE4_OFFSET_LOW	STAGE4 initial offset low value
0x0A5	[15:0]	X	R/W	STAGE4_OFFSET_HIGH	STAGE4 initial offset high value
0x0A6	[15:0]	X	R/W	STAGE4_OFFSET_HIGH_CLAMP	STAGE4 offset high clamp value
0x0A7	[15:0]	X	R/W	STAGE4_OFFSET_LOW_CLAMP	STAGE4 offset low clamp value

Table 38. STAGE5 Configuration Registers

Address	Data Bit	Default Value	Type	Name	Description
0x0A8	[15:0]	X	R/W	STAGE5_CONNECTION[6:0]	STAGE5 CIN(6:0) connection setup (see Table 45)
0x0A9	[15:0]	X	R/W	STAGE5_CONNECTION[13:7]	STAGE5 CIN(13:7) connection setup (see Table 46)
0x0AA	[15:0]	X	R/W	STAGE5_AFE_OFFSET	STAGE5 AFE offset control (see Table 47)
0x0AB	[15:0]	X	R/W	STAGE5_SENSITIVITY	STAGE5 sensitivity control (see Table 48)
0x0AC	[15:0]	X	R/W	STAGE5_OFFSET_LOW	STAGE5 initial offset low value
0x0AD	[15:0]	X	R/W	STAGE5_OFFSET_HIGH	STAGE5 initial offset high value
0x0AE	[15:0]	X	R/W	STAGE5_OFFSET_HIGH_CLAMP	STAGE5 offset high clamp value
0x0AF	[15:0]	X	R/W	STAGE5_OFFSET_LOW_CLAMP	STAGE5 offset low clamp value

**Table 39. STAGE6 Configuration Registers**

Address	Data Bit	Default Value	Type	Name	Description
0x0B0	[15:0]	X	R/W	STAGE6_CONNECTION[6:0]	STAGE6 CIN(6:0) connection setup (see Table 45)
0x0B1	[15:0]	X	R/W	STAGE6_CONNECTION[13:7]	STAGE6 CIN(13:7) connection setup (see Table 46)
0x0B2	[15:0]	X	R/W	STAGE6_AFE_OFFSET	STAGE6 AFE offset control (see Table 47)
0x0B3	[15:0]	X	R/W	STAGE6_SENSITIVITY	STAGE6 sensitivity control (see Table 48)
0x0B4	[15:0]	X	R/W	STAGE6_OFFSET_LOW	STAGE6 initial offset low value
0x0B5	[15:0]	X	R/W	STAGE6_OFFSET_HIGH	STAGE6 initial offset high value
0x0B6	[15:0]	X	R/W	STAGE6_OFFSET_HIGH_CLAMP	STAGE6 offset high clamp value
0x0B7	[15:0]	X	R/W	STAGE6_OFFSET_LOW_CLAMP	STAGE6 offset low clamp value

**Table 40. STAGE7 Configuration Registers**

Address	Data Bit	Default Value	Type	Name	Description
0x0B8	[15:0]	X	R/W	STAGE7_CONNECTION[6:0]	STAGE7 CIN(6:0) connection setup (see Table 45)
0x0B9	[15:0]	X	R/W	STAGE7_CONNECTION[13:7]	STAGE7 CIN(13:7) connection setup (see Table 46)
0x0BA	[15:0]	X	R/W	STAGE7_AFE_OFFSET	STAGE7 AFE offset control (see Table 47)
0x0BB	[15:0]	X	R/W	STAGE7_SENSITIVITY	STAGE7 sensitivity control (see Table 48)
0x0BC	[15:0]	X	R/W	STAGE7_OFFSET_LOW	STAGE7 initial offset low value
0x0BD	[15:0]	X	R/W	STAGE7_OFFSET_HIGH	STAGE7 initial offset high value
0x0BE	[15:0]	X	R/W	STAGE7_OFFSET_HIGH_CLAMP	STAGE7 offset high clamp value
0x0BF	[15:0]	X	R/W	STAGE7_OFFSET_LOW_CLAMP	STAGE7 offset low clamp value

**Table 41. STAGE8 Configuration Registers**

Address	Data Bit	Default Value	Type	Name	Description
0x0C0	[15:0]	X	R/W	STAGE8_CONNECTION[6:0]	STAGE8 CIN(6:0) connection setup (see Table 45)
0x0C1	[15:0]	X	R/W	STAGE8_CONNECTION[13:7]	STAGE8 CIN(13:7) connection setup (see Table 46)
0x0C2	[15:0]	X	R/W	STAGE8_AFE_OFFSET	STAGE8 AFE offset control (see Table 47)
0x0C3	[15:0]	X	R/W	STAGE8_SENSITIVITY	STAGE8 sensitivity control (see Table 48)
0x0C4	[15:0]	X	R/W	STAGE8_OFFSET_LOW	STAGE8 initial offset low value
0x0C5	[15:0]	X	R/W	STAGE8_OFFSET_HIGH	STAGE8 initial offset high value
0x0C6	[15:0]	X	R/W	STAGE8_OFFSET_HIGH_CLAMP	STAGE8 offset high clamp value
0x0C7	[15:0]	X	R/W	STAGE8_OFFSET_LOW_CLAMP	STAGE8 offset low clamp value

Table 42. STAGE9 Configuration Registers

Address	Data Bit	Default Value	Type	Name	Description
0x0C8	[15:0]	X	R/W	STAGE9_CONNECTION[6:0]	STAGE9 CIN(6:0) connection setup (see Table 45)
0x0C9	[15:0]	X	R/W	STAGE9_CONNECTION[13:7]	STAGE9 CIN(13:7) connection setup (see Table 46)
0x0CA	[15:0]	X	R/W	STAGE9_AFE_OFFSET	STAGE9 AFE offset control (see Table 47)
0x0CB	[15:0]	X	R/W	STAGE9_SENSITIVITY	STAGE9 sensitivity control (see Table 48)
0x0CC	[15:0]	X	R/W	STAGE9_OFFSET_LOW	STAGE9 initial offset low value
0x0CD	[15:0]	X	R/W	STAGE9_OFFSET_HIGH	STAGE9 initial offset high value
0x0CE	[15:0]	X	R/W	STAGE9_OFFSET_HIGH_CLAMP	STAGE9 offset high clamp value
0x0CF	[15:0]	X	R/W	STAGE9_OFFSET_LOW_CLAMP	STAGE9 offset low clamp value

Table 43. STAGE10 Configuration Registers

Address	Data Bit	Default Value	Type	Name	Description
0x0D0	[15:0]	X	R/W	STAGE10_CONNECTION[6:0]	STAGE10 CIN(6:0) connection setup (see Table 45)
0x0D1	[15:0]	X	R/W	STAGE10_CONNECTION[13:7]	STAGE10 CIN(13:7) connection setup (see Table 46)
0x0D2	[15:0]	X	R/W	STAGE10_AFE_OFFSET	STAGE10 AFE offset control (see Table 47)
0x0D3	[15:0]	X	R/W	STAGE10_SENSITIVITY	STAGE10 sensitivity control (see Table 48)
0x0D4	[15:0]	X	R/W	STAGE10_OFFSET_LOW	STAGE10 initial offset low value
0x0D5	[15:0]	X	R/W	STAGE10_OFFSET_HIGH	STAGE10 initial offset high value
0x0D6	[15:0]	X	R/W	STAGE10_OFFSET_HIGH_CLAMP	STAGE10 offset high clamp value
0x0D7	[15:0]	X	R/W	STAGE10_OFFSET_LOW_CLAMP	STAGE10 offset low clamp value

Table 44. STAGE11 Configuration Registers

Address	Data Bit	Default Value	Type	Name	Description
0x0D8	[15:0]	X	R/W	STAGE11_CONNECTION[6:0]	STAGE11 CIN(6:0) connection setup (see Table 45)
0x0D9	[15:0]	X	R/W	STAGE11_CONNECTION[13:7]	STAGE11 CIN(13:7) connection setup (see Table 46)
0x0DA	[15:0]	X	R/W	STAGE11_AFE_OFFSET	STAGE11 AFE offset control (see Table 47)
0x0DB	[15:0]	X	R/W	STAGE11_SENSITIVITY	STAGE11 sensitivity control (see Table 48)
0x0DC	[15:0]	X	R/W	STAGE11_OFFSET_LOW	STAGE11 initial offset low value
0x0DD	[15:0]	X	R/W	STAGE11_OFFSET_HIGH	STAGE11 initial offset high value
0x0DE	[15:0]	X	R/W	STAGE11_OFFSET_HIGH_CLAMP	STAGE11 offset high clamp value
0x0DF	[15:0]	X	R/W	STAGE11_OFFSET_LOW_CLAMP	STAGE11 offset low clamp value

**Table 45. STAGEX Detailed CIN (0:6) Connection Setup Description (X = 0 to 11)**

<b>Data Bit</b>	<b>Default Value</b>	<b>Type</b>	<b>Name</b>	<b>Description</b>
[1:0]	X	R/W	CIN0_CONNECTION_SETUP	CIN0 connection setup 00 = CIN0 not connected to CDC inputs 01 = CIN0 connected to CDC negative input 10 = CIN0 connected to CDC positive input 11 = CIN0 connected to BIAS (connect unused CIN inputs)
[3:2]	X	R/W	CIN1_CONNECTION_SETUP	CIN1 connection setup 00 = CIN1 not connected to CDC inputs 01 = CIN1 connected to CDC negative input 10 = CIN1 connected to CDC positive input 11 = CIN1 connected to BIAS (connect unused CIN inputs)
[5:4]	X	R/W	CIN2_CONNECTION_SETUP	CIN2 connection setup 00 = CIN2 not connected to CDC inputs 01 = CIN2 connected to CDC negative input 10 = CIN2 connected to CDC positive input 11 = CIN2 connected to BIAS (connect unused CIN inputs)
[7:6]	X	R/W	CIN3_CONNECTION_SETUP	CIN3 connection setup 00 = CIN3 not connected to CDC inputs 01 = CIN3 connected to CDC negative input 10 = CIN3 connected to CDC positive input 11 = CIN3 connected to BIAS (connect unused CIN inputs)
[9:8]	X	R/W	CIN4_CONNECTION_SETUP	CIN4 connection setup 00 = CIN4 not connected to CDC inputs 01 = CIN4 connected to CDC negative input 10 = CIN4 connected to CDC positive input 11 = CIN4 connected to BIAS (connect unused CIN inputs)
[11:10]	X	R/W	CIN5_CONNECTION_SETUP	CIN5 connection setup 00 = CIN5 not connected to CDC inputs 01 = CIN5 connected to CDC negative input 10 = CIN5 connected to CDC positive input 11 = CIN5 connected to BIAS (connect unused CIN inputs)
[13:12]	X	R/W	CIN6_CONNECTION_SETUP	CIN6 connection setup 00 = CIN6 not connected to CDC inputs 01 = CIN6 connected to CDC negative input 10 = CIN6 connected to CDC positive input 11 = CIN6 connected to BIAS (connect unused CIN inputs)
[15:14]	X		Unused	Set unused register bits = 0

Table 46. STAGEX Detailed CIN (7:13) Connection Setup Description (X = 0 to 11)

Data Bit	Default Value	Type	Name	Description
[1:0]	X	R/W	CIN7_CONNECTION_SETUP	CIN7 connection setup 00 = CIN7 not connected to CDC inputs 01 = CIN7 connected to CDC negative input 10 = CIN7 connected to CDC positive input 11 = CIN7 connected to BIAS (connect unused CIN inputs)
[3:2]	X	R/W	CIN8_CONNECTION_SETUP	CIN8 connection setup 00 = CIN8 not connected to CDC inputs 01 = CIN8 connected to CDC negative input 10 = CIN8 connected to CDC positive input 11 = CIN8 connected to BIAS (connect unused CIN inputs)
[5:4]	X	R/W	CIN9_CONNECTION_SETUP	CIN9 connection setup 00 = CIN9 not connected to CDC inputs 01 = CIN9 connected to CDC negative input 10 = CIN9 connected to CDC positive input 11 = CIN9 connected to BIAS (connect unused CIN inputs)
[7:6]	X	R/W	CIN10_CONNECTION_SETUP	CIN10 connection setup 00 = CIN10 not connected to CDC inputs 01 = CIN10 connected to CDC negative input 10 = CIN10 connected to CDC positive input 11 = CIN10 connected to BIAS (connect unused CIN inputs)
[9:8]	X	R/W	CIN11_CONNECTION_SETUP	CIN11 connection setup 00 = CIN11 not connected to CDC inputs 01 = CIN11 connected to CDC negative input 10 = CIN11 connected to CDC positive input 11 = CIN11 connected to BIAS (connect unused CIN inputs)
[11:10]	X	R/W	CIN12_CONNECTION_SETUP	CIN12 connection setup 00 = CIN12 not connected to CDC inputs 01 = CIN12 connected to CDC negative input 10 = CIN12 connected to CDC positive input 11 = CIN12 connected to BIAS (connect unused CIN inputs)
[13:12]	X	R/W	CIN13_CONNECTION_SETUP	CIN13 connection setup 00 = CIN13 not connected to CDC inputs 01 = CIN13 connected to CDC negative input 10 = CIN13 connected to CDC positive input 11 = CIN13 connected to BIAS (connect unused CIN inputs)
[14]	X		NEG_AFE_OFFSET_DISABLE	Negative AFE offset enable control 0 = enable 1 = disable
[15]	X		POS_AFE_OFFSET_DISABLE	Positive AFE offset enable control 0 = enable 1 = disable



# AD7142

**Table 47. STAGEX Detailed Offset Control Description (X = 0 to 11)**

Data Bit	Default Value	Type	Name	Description
[6:0]	X	R/W	NEG_AFE_OFFSET	Negative AFE offset setting (20 pF range) 1 LSB value = 0.16 pF of offset
[7]	X	R/W	NEG_AFE_OFFSET_SWAP	Negative AFE offset swap control 0 = NEG_AFE_OFFSET applied to CDC negative input 1 = NEG_AFE_OFFSET applied to CDC positive input
[14:8]	X	R/W	POS_AFE_OFFSET	Positive AFE offset setting (20 pF range) 1 LSB value = 0.16 pF of offset
[15]	X	R/W	POS_AFE_OFFSET_SWAP	Positive AFE offset swap control 0 = POS_AFE_OFFSET applied to CDC positive input 1 = POS_AFE_OFFSET applied to CDC negative input

**Table 48. STAGEX Detailed Sensitivity Control Description (X = 0 to 11)**

Data Bit	Default Value	Type	Name	Description
[3:0]	X	R/W	NEG_THRESHOLD_SENSITIVITY	Negative threshold sensitivity control 0000 = 25%, 0001 = 29.73%, 0010 = 34.40%, 0011 = 39.08% 0100 = 43.79%, 0101 = 48.47%, 0110 = 53.15% 0111 = 57.83%, 1000 = 62.51%, 1001 = 67.22% 1010 = 71.90%, 1011 = 76.58%, 1100 = 81.28% 1101 = 85.96%, 1110 = 90.64%, 1111 = 95.32%
[6:4]	X	R/W	NEG_PEAK_DETECT	Negative peak detect setting 000 = 40% level, 001 = 50% level, 010 = 60% level 011 = 70% level, 100 = 80% level, 101 = 90% level
[7]	X	R/W	Unused	Set unused register bits = 0
[11:8]	X	R/W	POS_THRESHOLD_SENSITIVITY	Positive threshold sensitivity control 0000 = 25%, 0001 = 29.73%, 0010 = 34.40%, 0011 = 39.08% 0100 = 43.79%, 0101 = 48.47%, 0110 = 53.15% 0111 = 57.83%, 1000 = 62.51%, 1001 = 67.22% 1010 = 71.90%, 1011 = 76.58%, 1100 = 81.28% 1101 = 85.96%, 1110 = 90.64%, 1111 = 95.32%
[14:12]	X	R/W	POS_PEAK_DETECT	Positive peak detect setting 000 = 40% level, 001 = 50% level, 010 = 60% level 011 = 70% level, 100 = 80% level, 101 = 90% level
[15]	X	R/W	Unused	Set unused register bits = 0

**BANK 3 REGISTERS**

All address values are expressed in hexadecimal.

**Table 49. STAGE0 Results Registers**

Address	Data Bit	Default Value	Type	Name	Description
0x0E0	[15:0]	X	R/W	STAGE0_CONV_DATA	STAGE0 CDC 16-bit conversion data (copy of data in STAGE0_CONV_DATA register)
0x0E1	[15:0]	X	R/W	STAGE0_FF_WORD0	STAGE0 fast FIFO WORD0
0x0E2	[15:0]	X	R/W	STAGE0_FF_WORD1	STAGE0 fast FIFO WORD1
0x0E3	[15:0]	X	R/W	STAGE0_FF_WORD2	STAGE0 fast FIFO WORD2
0x0E4	[15:0]	X	R/W	STAGE0_FF_WORD3	STAGE0 fast FIFO WORD3
0x0E5	[15:0]	X	R/W	STAGE0_FF_WORD4	STAGE0 fast FIFO WORD4
0x0E6	[15:0]	X	R/W	STAGE0_FF_WORD5	STAGE0 fast FIFO WORD5
0x0E7	[15:0]	X	R/W	STAGE0_FF_WORD6	STAGE0 fast FIFO WORD6
0x0E8	[15:0]	X	R/W	STAGE0_FF_WORD7	STAGE0 fast FIFO WORD7
0x0E9	[15:0]	X	R/W	STAGE0_SF_WORD0	STAGE0 slow FIFO WORD0
0x0EA	[15:0]	X	R/W	STAGE0_SF_WORD1	STAGE0 slow FIFO WORD1
0x0EB	[15:0]	X	R/W	STAGE0_SF_WORD2	STAGE0 slow FIFO WORD2
0x0EC	[15:0]	X	R/W	STAGE0_SF_WORD3	STAGE0 slow FIFO WORD3
0x0ED	[15:0]	X	R/W	STAGE0_SF_WORD4	STAGE0 slow FIFO WORD4
0x0EE	[15:0]	X	R/W	STAGE0_SF_WORD5	STAGE0 slow FIFO WORD5
0x0EF	[15:0]	X	R/W	STAGE0_SF_WORD6	STAGE0 slow FIFO WORD6
0x0F0	[15:0]	X	R/W	STAGE0_SF_WORD7	STAGE0 slow FIFO WORD7
0x0F1	[15:0]	X	R/W	STAGE0_SF_AMBIENT	STAGE0 slow FIFO ambient value
0x0F2	[15:0]	X	R/W	STAGE0_FF_AVG	STAGE0 fast FIFO average value
0x0F3	[15:0]	X	R/W	STAGE0_PEAK_DETECT_WORD0	STAGE0 peak FIFO WORD0 value
0x0F4	[15:0]	X	R/W	STAGE0_PEAK_DETECT_WORD1	STAGE0 peak FIFO WORD1 value
0x0F5	[15:0]	X	R/W	STAGE0_MAX_WORD0	STAGE0 maximum value FIFO WORD0
0x0F6	[15:0]	X	R/W	STAGE0_MAX_WORD1	STAGE0 maximum value FIFO WORD1
0x0F7	[15:0]	X	R/W	STAGE0_MAX_WORD2	STAGE0 maximum value FIFO WORD2
0x0F8	[15:0]	X	R/W	STAGE0_MAX_WORD3	STAGE0 maximum value FIFO WORD3
0x0F9	[15:0]	X	R/W	STAGE0_MAX_AVG	STAGE0 average maximum FIFO value
0x0FA	[15:0]	X	R/W	STAGE0_HIGH_THRESHOLD	STAGE0 high threshold value
0x0FB	[15:0]	X	R/W	STAGE0_MAX_TEMP	STAGE0 temporary maximum value
0x0FC	[15:0]	X	R/W	STAGE0_MIN_WORD0	STAGE0 minimum value FIFO WORD0
0x0FD	[15:0]	X	R/W	STAGE0_MIN_WORD1	STAGE0 minimum value FIFO WORD1
0x0FE	[15:0]	X	R/W	STAGE0_MIN_WORD2	STAGE0 minimum value FIFO WORD2
0x0FF	[15:0]	X	R/W	STAGE0_MIN_WORD3	STAGE0 minimum value FIFO WORD3
0x100	[15:0]	X	R/W	STAGE0_MIN_AVG	STAGE0 average minimum FIFO value
0x101	[15:0]	X	R/W	STAGE0_LOW_THRESHOLD	STAGE0 low threshold value
0x102	[15:0]	X	R/W	STAGE0_MIN_TEMP	STAGE0 temporary minimum value
0x103	[15:0]	X	R/W	Unused	Set unused register bits = 0

Table 50. STAGE1 Results Registers

Address	Data Bit	Default Value	Type	Name	Description
0x104	[15:0]	X	R/W	STAGE1_CONV_DATA	STAGE1 CDC 16-bit conversion data (copy of data in STAGE1_CONV_DATA register)
0x105	[15:0]	X	R/W	STAGE1_FF_WORD0	STAGE1 fast FIFO WORD0
0x106	[15:0]	X	R/W	STAGE1_FF_WORD1	STAGE1 fast FIFO WORD1
0x107	[15:0]	X	R/W	STAGE1_FF_WORD2	STAGE1 fast FIFO WORD2
0x108	[15:0]	X	R/W	STAGE1_FF_WORD3	STAGE1 fast FIFO WORD3
0x109	[15:0]	X	R/W	STAGE1_FF_WORD4	STAGE1 fast FIFO WORD4
0x10A	[15:0]	X	R/W	STAGE1_FF_WORD5	STAGE1 fast FIFO WORD5
0x10B	[15:0]	X	R/W	STAGE1_FF_WORD6	STAGE1 fast FIFO WORD6
0x10C	[15:0]	X	R/W	STAGE1_FF_WORD7	STAGE1 fast FIFO WORD7
0x10D	[15:0]	X	R/W	STAGE1_SF_WORD0	STAGE1 slow FIFO WORD0
0x10E	[15:0]	X	R/W	STAGE1_SF_WORD1	STAGE1 slow FIFO WORD1
0x10F	[15:0]	X	R/W	STAGE1_SF_WORD2	STAGE1 slow FIFO WORD2
0x110	[15:0]	X	R/W	STAGE1_SF_WORD3	STAGE1 slow FIFO WORD3
0x111	[15:0]	X	R/W	STAGE1_SF_WORD4	STAGE1 slow FIFO WORD4
0x112	[15:0]	X	R/W	STAGE1_SF_WORD5	STAGE1 slow FIFO WORD5
0x113	[15:0]	X	R/W	STAGE1_SF_WORD6	STAGE1 slow FIFO WORD6
0x114	[15:0]	X	R/W	STAGE1_SF_WORD7	STAGE1 slow FIFO WORD7
0x115	[15:0]	X	R/W	STAGE1_SF_AMBIENT	STAGE1 slow FIFO ambient value
0x116	[15:0]	X	R/W	STAGE1_FF_AVG	STAGE1 fast FIFO average value
0x117	[15:0]	X	R/W	STAGE1_CDC_WORD0	STAGE1 CDC FIFO WORD0
0x118	[15:0]	X	R/W	STAGE1_CDC_WORD1	STAGE1 CDC FIFO WORD1
0x119	[15:0]	X	R/W	STAGE1_MAX_WORD0	STAGE1 maximum value FIFO WORD0
0x11A	[15:0]	X	R/W	STAGE1_MAX_WORD1	STAGE1 maximum value FIFO WORD1
0x11B	[15:0]	X	R/W	STAGE1_MAX_WORD2	STAGE1 maximum value FIFO WORD2
0x11C	[15:0]	X	R/W	STAGE1_MAX_WORD3	STAGE1 maximum value FIFO WORD3
0x11D	[15:0]	X	R/W	STAGE1_MAX_AVG	STAGE1 average maximum FIFO value
0x11E	[15:0]	X	R/W	STAGE1_HIGH_THRESHOLD	STAGE1 high threshold value
0x11F	[15:0]	X	R/W	STAGE1_MAX_TEMP	STAGE1 temporary maximum value
0x120	[15:0]	X	R/W	STAGE1_MIN_WORD0	STAGE1 minimum value FIFO WORD0
0x121	[15:0]	X	R/W	STAGE1_MIN_WORD1	STAGE1 minimum value FIFO WORD1
0x122	[15:0]	X	R/W	STAGE1_MIN_WORD2	STAGE1 minimum value FIFO WORD2
0x123	[15:0]	X	R/W	STAGE1_MIN_WORD3	STAGE1 minimum value FIFO WORD3
0x124	[15:0]	X	R/W	STAGE1_MIN_AVG	STAGE1 average minimum FIFO value
0x125	[15:0]	X	R/W	STAGE1_LOW_THRESHOLD	STAGE1 low threshold value
0x126	[15:0]	X	R/W	STAGE1_MIN_TEMP	STAGE1 temporary minimum value
0x127	[15:0]	X	R/W	Unused	Set unused register bits = 0

Table 51. STAGE2 Results Registers

Address	Data Bit	Default Value	Type	Name	Description
0x128	[15:0]	X	R/W	STAGE2_CONV_DATA	STAGE2 CDC 16-bit conversion data (copy of data in STAGE2_CONV_DATA register)
0x129	[15:0]	X	R/W	STAGE2_FF_WORD0	STAGE2 fast FIFO WORD0
0x12A	[15:0]	X	R/W	STAGE2_FF_WORD1	STAGE2 fast FIFO WORD1
0x12B	[15:0]	X	R/W	STAGE2_FF_WORD2	STAGE2 fast FIFO WORD2
0x12C	[15:0]	X	R/W	STAGE2_FF_WORD3	STAGE2 fast FIFO WORD3
0x12D	[15:0]	X	R/W	STAGE2_FF_WORD4	STAGE2 fast FIFO WORD4
0x12E	[15:0]	X	R/W	STAGE2_FF_WORD5	STAGE2 fast FIFO WORD5
0x12F	[15:0]	X	R/W	STAGE2_FF_WORD6	STAGE2 fast FIFO WORD6
0x130	[15:0]	X	R/W	STAGE2_FF_WORD7	STAGE2 fast FIFO WORD7
0x131	[15:0]	X	R/W	STAGE2_SF_WORD0	STAGE2 slow FIFO WORD0
0x132	[15:0]	X	R/W	STAGE2_SF_WORD1	STAGE2 slow FIFO WORD1
0x133	[15:0]	X	R/W	STAGE2_SF_WORD2	STAGE2 slow FIFO WORD2
0x134	[15:0]	X	R/W	STAGE2_SF_WORD3	STAGE2 slow FIFO WORD3
0x135	[15:0]	X	R/W	STAGE2_SF_WORD4	STAGE2 slow FIFO WORD4
0x136	[15:0]	X	R/W	STAGE2_SF_WORD5	STAGE2 slow FIFO WORD5
0x137	[15:0]	X	R/W	STAGE2_SF_WORD6	STAGE2 slow FIFO WORD6
0x138	[15:0]	X	R/W	STAGE2_SF_WORD7	STAGE2 slow FIFO WORD7
0x139	[15:0]	X	R/W	STAGE2_SF_AMBIENT	STAGE2 slow FIFO ambient value
0x13A	[15:0]	X	R/W	STAGE2_FF_AVG	STAGE2 fast FIFO average value
0x13B	[15:0]	X	R/W	STAGE2_CDC_WORD0	STAGE2 CDC FIFO WORD0
0x13C	[15:0]	X	R/W	STAGE2_CDC_WORD1	STAGE2 CDC FIFO WORD1
0x13D	[15:0]	X	R/W	STAGE2_MAX_WORD0	STAGE2 maximum value FIFO WORD0
0x13E	[15:0]	X	R/W	STAGE2_MAX_WORD1	STAGE2 maximum value FIFO WORD1
0x13F	[15:0]	X	R/W	STAGE2_MAX_WORD2	STAGE2 maximum value FIFO WORD2
0x140	[15:0]	X	R/W	STAGE2_MAX_WORD3	STAGE2 maximum value FIFO WORD3
0x141	[15:0]	X	R/W	STAGE2_MAX_AVG	STAGE2 average maximum FIFO value
0x142	[15:0]	X	R/W	STAGE2_HIGH_THRESHOLD	STAGE2 high threshold value
0x143	[15:0]	X	R/W	STAGE2_MAX_TEMP	STAGE2 temporary maximum value
0x144	[15:0]	X	R/W	STAGE2_MIN_WORD0	STAGE2 minimum value FIFO WORD0
0x145	[15:0]	X	R/W	STAGE2_MIN_WORD1	STAGE2 minimum value FIFO WORD1
0x146	[15:0]	X	R/W	STAGE2_MIN_WORD2	STAGE2 minimum value FIFO WORD2
0x147	[15:0]	X	R/W	STAGE2_MIN_WORD3	STAGE2 minimum value FIFO WORD3
0x148	[15:0]	X	R/W	STAGE2_MIN_AVG	STAGE2 average minimum FIFO value
0x149	[15:0]	X	R/W	STAGE2_LOW_THRESHOLD	STAGE2 low threshold value
0x14A	[15:0]	X	R/W	STAGE2_MIN_TEMP	STAGE2 temporary minimum value
0x14B	[15:0]	X	R/W	Unused	Set unused register bits = 0

**Table 52. STAGE3 Results Registers**

Address	Data Bit	Default Value	Type	Name	Description
0x14C	[15:0]	X	R/W	STAGE3_CONV_DATA	STAGE3 CDC 16-bit conversion data (copy of data in STAGE3_CONV_DATA register)
0x14D	[15:0]	X	R/W	STAGE3_FF_WORD0	STAGE3 fast FIFO WORD0
0x14E	[15:0]	X	R/W	STAGE3_FF_WORD1	STAGE3 fast FIFO WORD1
0x14F	[15:0]	X	R/W	STAGE3_FF_WORD2	STAGE3 fast FIFO WORD2
0x150	[15:0]	X	R/W	STAGE3_FF_WORD3	STAGE3 fast FIFO WORD3
0x151	[15:0]	X	R/W	STAGE3_FF_WORD4	STAGE3 fast FIFO WORD4
0x152	[15:0]	X	R/W	STAGE3_FF_WORD5	STAGE3 fast FIFO WORD5
0x153	[15:0]	X	R/W	STAGE3_FF_WORD6	STAGE3 fast FIFO WORD6
0x154	[15:0]	X	R/W	STAGE3_FF_WORD7	STAGE3 fast FIFO WORD7
0x155	[15:0]	X	R/W	STAGE3_SF_WORD0	STAGE3 slow FIFO WORD0
0x156	[15:0]	X	R/W	STAGE3_SF_WORD1	STAGE3 slow FIFO WORD1
0x157	[15:0]	X	R/W	STAGE3_SF_WORD2	STAGE3 slow FIFO WORD2
0x158	[15:0]	X	R/W	STAGE3_SF_WORD3	STAGE3 slow FIFO WORD3
0x159	[15:0]	X	R/W	STAGE3_SF_WORD4	STAGE3 slow FIFO WORD4
0x15A	[15:0]	X	R/W	STAGE3_SF_WORD5	STAGE3 slow FIFO WORD5
0x15B	[15:0]	X	R/W	STAGE3_SF_WORD6	STAGE3 slow FIFO WORD6
0x15C	[15:0]	X	R/W	STAGE3_SF_WORD7	STAGE3 slow FIFO WORD7
0x15D	[15:0]	X	R/W	STAGE3_SF_AMBIENT	STAGE3 slow FIFO ambient value
0x15E	[15:0]	X	R/W	STAGE3_FF_AVG	STAGE3 fast FIFO average value
0x15F	[15:0]	X	R/W	STAGE3_CDC_WORD0	STAGE3 CDC FIFO WORD0
0x160	[15:0]	X	R/W	STAGE3_CDC_WORD1	STAGE3 CDC FIFO WORD1
0x161	[15:0]	X	R/W	STAGE3_MAX_WORD0	STAGE3 maximum value FIFO WORD0
0x162	[15:0]	X	R/W	STAGE3_MAX_WORD1	STAGE3 maximum value FIFO WORD1
0x163	[15:0]	X	R/W	STAGE3_MAX_WORD2	STAGE3 maximum value FIFO WORD2
0x164	[15:0]	X	R/W	STAGE3_MAX_WORD3	STAGE3 maximum value FIFO WORD3
0x165	[15:0]	X	R/W	STAGE3_MAX_AVG	STAGE3 average maximum FIFO value
0x166	[15:0]	X	R/W	STAGE3_HIGH_THRESHOLD	STAGE3 high threshold value
0x167	[15:0]	X	R/W	STAGE3_MAX_TEMP	STAGE3 temporary maximum value
0x168	[15:0]	X	R/W	STAGE3_MIN_WORD0	STAGE3 minimum value FIFO WORD0
0x169	[15:0]	X	R/W	STAGE3_MIN_WORD1	STAGE3 minimum value FIFO WORD1
0x16A	[15:0]	X	R/W	STAGE3_MIN_WORD2	STAGE3 minimum value FIFO WORD2
0x16B	[15:0]	X	R/W	STAGE3_MIN_WORD3	STAGE3 minimum value FIFO WORD3
0x16C	[15:0]	X	R/W	STAGE3_MIN_AVG	STAGE3 average minimum FIFO value
0x16D	[15:0]	X	R/W	STAGE3_LOW_THRESHOLD	STAGE3 low threshold value
0x16E	[15:0]	X	R/W	STAGE3_MIN_TEMP	STAGE3 temporary minimum value
0x16F	[15:0]	X	R/W	Unused	Set unused register bits = 0

Table 53. STAGE4 Results Registers

Address	Data Bit	Default Value	Type	Name	Description
0x170	[15:0]	X	R/W	STAGE4_CONV_DATA	STAGE4 CDC 16-bit conversion data (copy of data in STAGE4_CONV_DATA register)
0x171	[15:0]	X	R/W	STAGE4_FF_WORD0	STAGE4 fast FIFO WORD0
0x172	[15:0]	X	R/W	STAGE4_FF_WORD1	STAGE4 fast FIFO WORD1
0x173	[15:0]	X	R/W	STAGE4_FF_WORD2	STAGE4 fast FIFO WORD2
0x174	[15:0]	X	R/W	STAGE4_FF_WORD3	STAGE4 fast FIFO WORD3
0x175	[15:0]	X	R/W	STAGE4_FF_WORD4	STAGE4 fast FIFO WORD4
0x176	[15:0]	X	R/W	STAGE4_FF_WORD5	STAGE4 fast FIFO WORD5
0x177	[15:0]	X	R/W	STAGE4_FF_WORD6	STAGE4 fast FIFO WORD6
0x178	[15:0]	X	R/W	STAGE4_FF_WORD7	STAGE4 fast FIFO WORD7
0x179	[15:0]	X	R/W	STAGE4_SF_WORD0	STAGE4 slow FIFO WORD0
0x17A	[15:0]	X	R/W	STAGE4_SF_WORD1	STAGE4 slow FIFO WORD1
0x17B	[15:0]	X	R/W	STAGE4_SF_WORD2	STAGE4 slow FIFO WORD2
0x17C	[15:0]	X	R/W	STAGE4_SF_WORD3	STAGE4 slow FIFO WORD3
0x17D	[15:0]	X	R/W	STAGE4_SF_WORD4	STAGE4 slow FIFO WORD4
0x17E	[15:0]	X	R/W	STAGE4_SF_WORD5	STAGE4 slow FIFO WORD5
0x17F	[15:0]	X	R/W	STAGE4_SF_WORD6	STAGE4 slow FIFO WORD6
0x180	[15:0]	X	R/W	STAGE4_SF_WORD7	STAGE4 slow FIFO WORD7
0x181	[15:0]	X	R/W	STAGE4_SF_AMBIENT	STAGE4 slow FIFO ambient value
0x182	[15:0]	X	R/W	STAGE4_FF_AVG	STAGE4 fast FIFO average value
0x183	[15:0]	X	R/W	STAGE4_CDC_WORD0	STAGE4 CDC FIFO WORD0
0x184	[15:0]	X	R/W	STAGE4_CDC_WORD1	STAGE4 CDC FIFO WORD1
0x185	[15:0]	X	R/W	STAGE4_MAX_WORD0	STAGE4 maximum value FIFO WORD0
0x186	[15:0]	X	R/W	STAGE4_MAX_WORD1	STAGE4 maximum value FIFO WORD1
0x187	[15:0]	X	R/W	STAGE4_MAX_WORD2	STAGE4 maximum value FIFO WORD2
0x188	[15:0]	X	R/W	STAGE4_MAX_WORD3	STAGE4 maximum value FIFO WORD3
0x189	[15:0]	X	R/W	STAGE4_MAX_AVG	STAGE4 average maximum FIFO value
0x18A	[15:0]	X	R/W	STAGE4_HIGH_THRESHOLD	STAGE4 high threshold value
0x18B	[15:0]	X	R/W	STAGE4_MAX_TEMP	STAGE4 temporary maximum value
0x18C	[15:0]	X	R/W	STAGE4_MIN_WORD0	STAGE4 minimum value FIFO WORD0
0x18D	[15:0]	X	R/W	STAGE4_MIN_WORD1	STAGE4 minimum value FIFO WORD1
0x18E	[15:0]	X	R/W	STAGE4_MIN_WORD2	STAGE4 minimum value FIFO WORD2
0x18F	[15:0]	X	R/W	STAGE4_MIN_WORD3	STAGE4 minimum value FIFO WORD3
0x190	[15:0]	X	R/W	STAGE4_MIN_AVG	STAGE4 average minimum FIFO value
0x191	[15:0]	X	R/W	STAGE4_LOW_THRESHOLD	STAGE4 low threshold value
0x192	[15:0]	X	R/W	STAGE4_MIN_TEMP	STAGE4 temporary minimum value
0x193	[15:0]	X	R/W	Unused	Set unused register bits = 0

Table 54. STAGE5 Results Registers

Address	Data Bit	Default Value	Type	Name	Description
0x194	[15:0]	X	R/W	STAGE5_CONV_DATA	STAGE5 CDC 16-bit conversion data (copy of data in STAGE5_CONV_DATA register)
0x195	[15:0]	X	R/W	STAGE5_FF_WORD0	STAGE5 fast FIFO WORD0
0x196	[15:0]	X	R/W	STAGE5_FF_WORD1	STAGE5 fast FIFO WORD1
0x197	[15:0]	X	R/W	STAGE5_FF_WORD2	STAGE5 fast FIFO WORD2
0x198	[15:0]	X	R/W	STAGE5_FF_WORD3	STAGE5 fast FIFO WORD3
0x199	[15:0]	X	R/W	STAGE5_FF_WORD4	STAGE5 fast FIFO WORD4
0x19A	[15:0]	X	R/W	STAGE5_FF_WORD5	STAGE5 fast FIFO WORD5
0x19B	[15:0]	X	R/W	STAGE5_FF_WORD6	STAGE5 fast FIFO WORD6
0x19C	[15:0]	X	R/W	STAGE5_FF_WORD7	STAGE5 fast FIFO WORD7
0x19D	[15:0]	X	R/W	STAGE5_SF_WORD0	STAGE5 slow FIFO WORD0
0x19E	[15:0]	X	R/W	STAGE5_SF_WORD1	STAGE5 slow FIFO WORD1
0x19F	[15:0]	X	R/W	STAGE5_SF_WORD2	STAGE5 slow FIFO WORD2
0x1A0	[15:0]	X	R/W	STAGE5_SF_WORD3	STAGE5 slow FIFO WORD3
0x1A1	[15:0]	X	R/W	STAGE5_SF_WORD4	STAGE5 slow FIFO WORD4
0x1A2	[15:0]	X	R/W	STAGE5_SF_WORD5	STAGE5 slow FIFO WORD5
0x1A3	[15:0]	X	R/W	STAGE5_SF_WORD6	STAGE5 slow FIFO WORD6
0x1A4	[15:0]	X	R/W	STAGE5_SF_WORD7	STAGE5 slow FIFO WORD7
0x1A5	[15:0]	X	R/W	STAGE5_SF_AMBIENT	STAGE5 slow FIFO ambient value
0x1A6	[15:0]	X	R/W	STAGE5_FF_AVG	STAGE5 fast FIFO average value
0x1A7	[15:0]	X	R/W	STAGE5_CDC_WORD0	STAGE5 CDC FIFO WORD0
0x1A8	[15:0]	X	R/W	STAGE5_CDC_WORD1	STAGE5 CDC FIFO WORD1
0x1A9	[15:0]	X	R/W	STAGE5_MAX_WORD0	STAGE5 maximum value FIFO WORD0
0x1AA	[15:0]	X	R/W	STAGE5_MAX_WORD1	STAGE5 maximum value FIFO WORD1
0x1AB	[15:0]	X	R/W	STAGE5_MAX_WORD2	STAGE5 maximum value FIFO WORD2
0x1AC	[15:0]	X	R/W	STAGE5_MAX_WORD3	STAGE5 maximum value FIFO WORD3
0x1AD	[15:0]	X	R/W	STAGE5_MAX_AVG	STAGE5 average maximum FIFO value
0x1AE	[15:0]	X	R/W	STAGE5_HIGH_THRESHOLD	STAGE5 high threshold value
0x1AF	[15:0]	X	R/W	STAGE5_MAX_TEMP	STAGE5 temporary maximum value
0x1B0	[15:0]	X	R/W	STAGE5_MIN_WORD0	STAGE5 minimum value FIFO WORD0
0x1B1	[15:0]	X	R/W	STAGE5_MIN_WORD1	STAGE5 minimum value FIFO WORD1
0x1B2	[15:0]	X	R/W	STAGE5_MIN_WORD2	STAGE5 minimum value FIFO WORD2
0x1B3	[15:0]	X	R/W	STAGE5_MIN_WORD3	STAGE5 minimum value FIFO WORD3
0x1B4	[15:0]	X	R/W	STAGE5_MIN_AVG	STAGE5 average minimum FIFO value
0x1B5	[15:0]	X	R/W	STAGE5_LOW_THRESHOLD	STAGE5 low threshold value
0x1B6	[15:0]	X	R/W	STAGE5_MIN_TEMP	STAGE5 temporary minimum value
0x1B7	[15:0]	X	R/W	Unused	Set unused register bits = 0

Table 55. STAGE6 Results Registers

Address	Data Bit	Default Value	Type	Name	Description
0x1B8	[15:0]	X	R/W	STAGE6_CONV_DATA	STAGE6 CDC 16-bit conversion data (copy of data in STAGE6_CONV_DATA register)
0x1B9	[15:0]	X	R/W	STAGE6_FF_WORD0	STAGE6 fast FIFO WORD0
0x1BA	[15:0]	X	R/W	STAGE6_FF_WORD1	STAGE6 fast FIFO WORD1
0x1BB	[15:0]	X	R/W	STAGE6_FF_WORD2	STAGE6 fast FIFO WORD2
0x1BC	[15:0]	X	R/W	STAGE6_FF_WORD3	STAGE6 fast FIFO WORD3
0x1BD	[15:0]	X	R/W	STAGE6_FF_WORD4	STAGE6 fast FIFO WORD4
0x1BE	[15:0]	X	R/W	STAGE6_FF_WORD5	STAGE6 fast FIFO WORD5
0x1BF	[15:0]	X	R/W	STAGE6_FF_WORD6	STAGE6 fast FIFO WORD6
0x1C0	[15:0]	X	R/W	STAGE6_FF_WORD7	STAGE6 fast FIFO WORD7
0x1C1	[15:0]	X	R/W	STAGE6_SF_WORD0	STAGE6 slow FIFO WORD0
0x1C2	[15:0]	X	R/W	STAGE6_SF_WORD1	STAGE6 slow FIFO WORD1
0x1C3	[15:0]	X	R/W	STAGE6_SF_WORD2	STAGE6 slow FIFO WORD2
0x1C4	[15:0]	X	R/W	STAGE6_SF_WORD3	STAGE6 slow FIFO WORD3
0x1C5	[15:0]	X	R/W	STAGE6_SF_WORD4	STAGE6 slow FIFO WORD4
0x1C6	[15:0]	X	R/W	STAGE6_SF_WORD5	STAGE6 slow FIFO WORD5
0x1C7	[15:0]	X	R/W	STAGE6_SF_WORD6	STAGE6 slow FIFO WORD6
0x1C8	[15:0]	X	R/W	STAGE6_SF_WORD7	STAGE6 slow FIFO WORD7
0x1C9	[15:0]	X	R/W	STAGE6_SF_AMBIENT	STAGE6 slow FIFO ambient value
0x1CA	[15:0]	X	R/W	STAGE6_FF_AVG	STAGE6 fast FIFO average value
0x1CB	[15:0]	X	R/W	STAGE6_CDC_WORD0	STAGE0 CDC FIFO WORD0
0x1CC	[15:0]	X	R/W	STAGE6_CDC_WORD1	STAGE6 CDC FIFO WORD1
0x1CD	[15:0]	X	R/W	STAGE6_MAX_WORD0	STAGE6 maximum value FIFO WORD0
0x1CE	[15:0]	X	R/W	STAGE6_MAX_WORD1	STAGE6 maximum value FIFO WORD1
0x1CF	[15:0]	X	R/W	STAGE6_MAX_WORD2	STAGE6 maximum value FIFO WORD2
0x1D0	[15:0]	X	R/W	STAGE6_MAX_WORD3	STAGE6 maximum value FIFO WORD3
0x1D1	[15:0]	X	R/W	STAGE6_MAX_AVG	STAGE6 average maximum FIFO value
0x1D2	[15:0]	X	R/W	STAGE6_HIGH_THRESHOLD	STAGE6 high threshold value
0x1D3	[15:0]	X	R/W	STAGE6_MAX_TEMP	STAGE6 temporary maximum value
0x1D4	[15:0]	X	R/W	STAGE6_MIN_WORD0	STAGE6 minimum value FIFO WORD0
0x1D5	[15:0]	X	R/W	STAGE6_MIN_WORD1	STAGE6 minimum value FIFO WORD1
0x1D6	[15:0]	X	R/W	STAGE6_MIN_WORD2	STAGE6 minimum value FIFO WORD2
0x1D7	[15:0]	X	R/W	STAGE6_MIN_WORD3	STAGE6 minimum value FIFO WORD3
0x1D8	[15:0]	X	R/W	STAGE6_MIN_AVG	STAGE6 average minimum FIFO value
0x1D9	[15:0]	X	R/W	STAGE6_LOW_THRESHOLD	STAGE6 low threshold value
0x1DA	[15:0]	X	R/W	STAGE6_MIN_TEMP	STAGE6 temporary minimum value
0x1DB	[15:0]	X	R/W	Unused	Set unused register bits = 0



Table 56. STAGE7 Results Registers

Address	Data Bit	Default Value	Type	Name	Description
0x1DC	[15:0]	X	R/W	STAGE7_CONV_DATA	STAGE7 CDC 16-bit conversion data (copy of data in STAGE7_CONV_DATA register)
0x1DD	[15:0]	X	R/W	STAGE7_FF_WORD0	STAGE7 fast FIFO WORD0
0x1DE	[15:0]	X	R/W	STAGE7_FF_WORD1	STAGE7 fast FIFO WORD1
0x1DF	[15:0]	X	R/W	STAGE7_FF_WORD2	STAGE7 fast FIFO WORD2
0x1E0	[15:0]	X	R/W	STAGE7_FF_WORD3	STAGE7 fast FIFO WORD3
0x1E1	[15:0]	X	R/W	STAGE7_FF_WORD4	STAGE7 fast FIFO WORD4
0x1E2	[15:0]	X	R/W	STAGE7_FF_WORD5	STAGE7 fast FIFO WORD5
0x1E3	[15:0]	X	R/W	STAGE7_FF_WORD6	STAGE7 fast FIFO WORD6
0x1E4	[15:0]	X	R/W	STAGE7_FF_WORD7	STAGE7 fast FIFO WORD7
0x1E5	[15:0]	X	R/W	STAGE7_SF_WORD0	STAGE7 slow FIFO WORD0
0x1E6	[15:0]	X	R/W	STAGE7_SF_WORD1	STAGE7 slow FIFO WORD1
0x1E7	[15:0]	X	R/W	STAGE7_SF_WORD2	STAGE7 slow FIFO WORD2
0x1E8	[15:0]	X	R/W	STAGE7_SF_WORD3	STAGE7 slow FIFO WORD3
0x1E9	[15:0]	X	R/W	STAGE7_SF_WORD4	STAGE7 slow FIFO WORD4
0x1EA	[15:0]	X	R/W	STAGE7_SF_WORD5	STAGE7 slow FIFO WORD5
0x1EB	[15:0]	X	R/W	STAGE7_SF_WORD6	STAGE7 slow FIFO WORD6
0x1EC	[15:0]	X	R/W	STAGE7_SF_WORD7	STAGE7 slow FIFO WORD7
0x1ED	[15:0]	X	R/W	STAGE7_SF_AMBIENT	STAGE7 slow FIFO ambient value
0x1EE	[15:0]	X	R/W	STAGE7_FF_AVG	STAGE7 fast FIFO average value
0x1EF	[15:0]	X	R/W	STAGE7_CDC_WORD0	STAGE7 CDC FIFO WORD0
0x1F0	[15:0]	X	R/W	STAGE7_CDC_WORD1	STAGE7 CDC FIFO WORD1
0x1F1	[15:0]	X	R/W	STAGE7_MAX_WORD0	STAGE7 maximum value FIFO WORD0
0x1F2	[15:0]	X	R/W	STAGE7_MAX_WORD1	STAGE7 maximum value FIFO WORD1
0x1F3	[15:0]	X	R/W	STAGE7_MAX_WORD2	STAGE7 maximum value FIFO WORD2
0x1F4	[15:0]	X	R/W	STAGE7_MAX_WORD3	STAGE7 maximum value FIFO WORD3
0x1F5	[15:0]	X	R/W	STAGE7_MAX_AVG	STAGE7 average maximum FIFO value
0x1F6	[15:0]	X	R/W	STAGE7_HIGH_THRESHOLD	STAGE7 high threshold value
0x1F7	[15:0]	X	R/W	STAGE7_MAX_TEMP	STAGE7 temporary maximum value
0x1F8	[15:0]	X	R/W	STAGE7_MIN_WORD0	STAGE7 minimum value FIFO WORD0
0x1F9	[15:0]	X	R/W	STAGE7_MIN_WORD1	STAGE7 minimum value FIFO WORD1
0x1FA	[15:0]	X	R/W	STAGE7_MIN_WORD2	STAGE7 minimum value FIFO WORD2
0x1FB	[15:0]	X	R/W	STAGE7_MIN_WORD3	STAGE7 minimum value FIFO WORD3
0x1FC	[15:0]	X	R/W	STAGE7_MIN_AVG	STAGE7 average minimum FIFO value
0x1FD	[15:0]	X	R/W	STAGE7_LOW_THRESHOLD	STAGE7 low threshold value
0x1FE	[15:0]	X	R/W	STAGE7_MIN_TEMP	STAGE7 temporary minimum value
0x1FF	[15:0]	X	R/W	Unused	Set unused register bits = 0

Table 57. STAGE8 Results Registers

Address	Data Bit	Default Value	Type	Name	Description
0x200	[15:0]	X	R/W	STAGE8_CONV_DATA	STAGE8 CDC 16-bit conversion data (copy of data in STAGE8_CONV_DATA register)
0x201	[15:0]	X	R/W	STAGE8_FF_WORD0	STAGE8 fast FIFO WORD0
0x202	[15:0]	X	R/W	STAGE8_FF_WORD1	STAGE8 fast FIFO WORD1
0x203	[15:0]	X	R/W	STAGE8_FF_WORD2	STAGE8 fast FIFO WORD2
0x204	[15:0]	X	R/W	STAGE8_FF_WORD3	STAGE8 fast FIFO WORD3
0x205	[15:0]	X	R/W	STAGE8_FF_WORD4	STAGE8 fast FIFO WORD4
0x206	[15:0]	X	R/W	STAGE8_FF_WORD5	STAGE8 fast FIFO WORD5
0x207	[15:0]	X	R/W	STAGE8_FF_WORD6	STAGE8 fast FIFO WORD6
0x208	[15:0]	X	R/W	STAGE8_FF_WORD7	STAGE8 fast FIFO WORD7
0x209	[15:0]	X	R/W	STAGE8_SF_WORD0	STAGE8 slow FIFO WORD0
0x20A	[15:0]	X	R/W	STAGE8_SF_WORD1	STAGE8 slow FIFO WORD1
0x20B	[15:0]	X	R/W	STAGE8_SF_WORD2	STAGE8 slow FIFO WORD2
0x20C	[15:0]	X	R/W	STAGE8_SF_WORD3	STAGE8 slow FIFO WORD3
0x20D	[15:0]	X	R/W	STAGE8_SF_WORD4	STAGE8 slow FIFO WORD4
0x20E	[15:0]	X	R/W	STAGE8_SF_WORD5	STAGE8 slow FIFO WORD5
0x20F	[15:0]	X	R/W	STAGE8_SF_WORD6	STAGE8 slow FIFO WORD6
0x210	[15:0]	X	R/W	STAGE8_SF_WORD7	STAGE8 slow FIFO WORD7
0x211	[15:0]	X	R/W	STAGE8_SF_AMBIENT	STAGE8 slow FIFO ambient value
0x212	[15:0]	X	R/W	STAGE8_FF_AVG	STAGE8 fast FIFO average value
0x213	[15:0]	X	R/W	STAGE8_CDC_WORD0	STAGE8 CDC FIFO WORD0
0x214	[15:0]	X	R/W	STAGE8_CDC_WORD1	STAGE8 CDC FIFO WORD1
0x215	[15:0]	X	R/W	STAGE8_MAX_WORD0	STAGE8 maximum value FIFO WORD0
0x216	[15:0]	X	R/W	STAGE8_MAX_WORD1	STAGE8 maximum value FIFO WORD1
0x217	[15:0]	X	R/W	STAGE8_MAX_WORD2	STAGE8 maximum value FIFO WORD2
0x218	[15:0]	X	R/W	STAGE8_MAX_WORD3	STAGE8 maximum value FIFO WORD3
0x219	[15:0]	X	R/W	STAGE8_MAX_AVG	STAGE8 average maximum FIFO value
0x21A	[15:0]	X	R/W	STAGE8_HIGH_THRESHOLD	STAGE8 high threshold value
0x21B	[15:0]	X	R/W	STAGE8_MAX_TEMP	STAGE8 temporary maximum value
0x21C	[15:0]	X	R/W	STAGE8_MIN_WORD0	STAGE8 minimum value FIFO WORD0
0x21D	[15:0]	X	R/W	STAGE8_MIN_WORD1	STAGE8 minimum value FIFO WORD1
0x21E	[15:0]	X	R/W	STAGE8_MIN_WORD2	STAGE8 minimum value FIFO WORD2
0x21F	[15:0]	X	R/W	STAGE8_MIN_WORD3	STAGE8 minimum value FIFO WORD3
0x220	[15:0]	X	R/W	STAGE8_MIN_AVG	STAGE8 average minimum FIFO value
0x221	[15:0]	X	R/W	STAGE8_LOW_THRESHOLD	STAGE8 low threshold value
0x222	[15:0]	X	R/W	STAGE8_MIN_TEMP	STAGE7 temporary minimum value
0x223	[15:0]	X	R/W	Unused	Set unused register bits = 0

Table 58. STAGE9 Results Registers

Address	Data Bit	Default Value	Type	Name	Description
0x224	[15:0]	X	R/W	STAGE9_CONV_DATA	STAGE9 CDC 16-bit conversion data (copy of data in STAGE9_CONV_DATA register)
0x225	[15:0]	X	R/W	STAGE9_FF_WORD0	STAGE9 fast FIFO WORD0
0x226	[15:0]	X	R/W	STAGE9_FF_WORD1	STAGE9 fast FIFO WORD1
0x227	[15:0]	X	R/W	STAGE9_FF_WORD2	STAGE9 fast FIFO WORD2
0x228	[15:0]	X	R/W	STAGE9_FF_WORD3	STAGE9 fast FIFO WORD3
0x229	[15:0]	X	R/W	STAGE9_FF_WORD4	STAGE9 fast FIFO WORD4
0x22A	[15:0]	X	R/W	STAGE9_FF_WORD5	STAGE9 fast FIFO WORD5
0x22B	[15:0]	X	R/W	STAGE9_FF_WORD6	STAGE9 fast FIFO WORD6
0x22C	[15:0]	X	R/W	STAGE9_FF_WORD7	STAGE9 fast FIFO WORD7
0x22D	[15:0]	X	R/W	STAGE9_SF_WORD0	STAGE9 slow FIFO WORD0
0x22E	[15:0]	X	R/W	STAGE9_SF_WORD1	STAGE9 slow FIFO WORD1
0x22F	[15:0]	X	R/W	STAGE9_SF_WORD2	STAGE9 slow FIFO WORD2
0x230	[15:0]	X	R/W	STAGE9_SF_WORD3	STAGE9 slow FIFO WORD3
0x231	[15:0]	X	R/W	STAGE9_SF_WORD4	STAGE9 slow FIFO WORD4
0x232	[15:0]	X	R/W	STAGE9_SF_WORD5	STAGE9 slow FIFO WORD5
0x233	[15:0]	X	R/W	STAGE9_SF_WORD6	STAGE9 slow FIFO WORD6
0x234	[15:0]	X	R/W	STAGE9_SF_WORD7	STAGE9 slow FIFO WORD7
0x235	[15:0]	X	R/W	STAGE9_SF_AMBIENT	STAGE9 slow FIFO ambient value
0x236	[15:0]	X	R/W	STAGE9_FF_AVG	STAGE9 fast FIFO average value
0x237	[15:0]	X	R/W	STAGE9_CDC_WORD0	STAGE9 CDC FIFO WORD0
0x238	[15:0]	X	R/W	STAGE9_CDC_WORD1	STAGE9 CDC FIFO WORD1
0x239	[15:0]	X	R/W	STAGE9_MAX_WORD0	STAGE9 maximum value FIFO WORD0
0x23A	[15:0]	X	R/W	STAGE9_MAX_WORD1	STAGE9 maximum value FIFO WORD1
0x23B	[15:0]	X	R/W	STAGE9_MAX_WORD2	STAGE9 maximum value FIFO WORD2
0x23C	[15:0]	X	R/W	STAGE9_MAX_WORD3	STAGE9 maximum value FIFO WORD3
0x23D	[15:0]	X	R/W	STAGE9_MAX_AVG	STAGE9 average maximum FIFO value
0x23E	[15:0]	X	R/W	STAGE9_HIGH_THRESHOLD	STAGE9 high threshold value
0x23F	[15:0]	X	R/W	STAGE9_MAX_TEMP	STAGE9 temporary maximum value
0x240	[15:0]	X	R/W	STAGE9_MIN_WORD0	STAGE9 minimum value FIFO WORD0
0x241	[15:0]	X	R/W	STAGE9_MIN_WORD1	STAGE9 minimum value FIFO WORD1
0x242	[15:0]	X	R/W	STAGE9_MIN_WORD2	STAGE9 minimum value FIFO WORD2
0x243	[15:0]	X	R/W	STAGE9_MIN_WORD3	STAGE9 minimum value FIFO WORD3
0x244	[15:0]	X	R/W	STAGE9_MIN_AVG	STAGE9 average minimum FIFO value
0x245	[15:0]	X	R/W	STAGE9_LOW_THRESHOLD	STAGE9 low threshold value
0x246	[15:0]	X	R/W	STAGE9_MIN_TEMP	STAGE9 temporary minimum value
0x247	[15:0]	X	R/W	Unused	Set unused register bits = 0

Table 59. STAGE10 Results Registers

Address	Data Bit	Default Value	Type	Name	Description
0x248	[15:0]	X	R/W	STAGE10_CONV_DATA	STAGE10 CDC 16-bit conversion data (copy of data in STAGE10_CONV_DATA register)
0x249	[15:0]	X	R/W	STAGE10_FF_WORD0	STAGE10 fast FIFO WORD0
0x24A	[15:0]	X	R/W	STAGE10_FF_WORD1	STAGE10 fast FIFO WORD1
0x24B	[15:0]	X	R/W	STAGE10_FF_WORD2	STAGE10 fast FIFO WORD2
0x24C	[15:0]	X	R/W	STAGE10_FF_WORD3	STAGE10 fast FIFO WORD3
0x24D	[15:0]	X	R/W	STAGE10_FF_WORD4	STAGE10 fast FIFO WORD4
0x24E	[15:0]	X	R/W	STAGE10_FF_WORDS5	STAGE10 fast FIFO WORD5
0x24F	[15:0]	X	R/W	STAGE10_FF_WORD6	STAGE10 fast FIFO WORD6
0x250	[15:0]	X	R/W	STAGE10_FF_WORD7	STAGE10 fast FIFO WORD7
0x251	[15:0]	X	R/W	STAGE10_SF_WORD0	STAGE10 slow FIFO WORD0
0x252	[15:0]	X	R/W	STAGE10_SF_WORD1	STAGE10 slow FIFO WORD1
0x253	[15:0]	X	R/W	STAGE10_SF_WORD2	STAGE10 slow FIFO WORD2
0x254	[15:0]	X	R/W	STAGE10_SF_WORD3	STAGE10 slow FIFO WORD3
0x255	[15:0]	X	R/W	STAGE10_SF_WORD4	STAGE10 slow FIFO WORD4
0x256	[15:0]	X	R/W	STAGE10_SF_WORDS5	STAGE10 slow FIFO WORD5
0x257	[15:0]	X	R/W	STAGE10_SF_WORD6	STAGE10 slow FIFO WORD6
0x258	[15:0]	X	R/W	STAGE10_SF_WORD7	STAGE10 slow FIFO WORD7
0x259	[15:0]	X	R/W	STAGE10_SF_AMBIENT	STAGE10 slow FIFO ambient value
0x25A	[15:0]	X	R/W	STAGE10_FF_AVG	STAGE10 fast FIFO average value
0x25B	[15:0]	X	R/W	STAGE10_CDC_WORD0	STAGE10 CDC FIFO WORD0
0x25C	[15:0]	X	R/W	STAGE10_CDC_WORD1	STAGE10 CDC FIFO WORD1
0x25D	[15:0]	X	R/W	STAGE10_MAX_WORD0	STAGE10 maximum value FIFO WORD0
0x25E	[15:0]	X	R/W	STAGE10_MAX_WORD1	STAGE10 maximum value FIFO WORD1
0x25F	[15:0]	X	R/W	STAGE10_MAX_WORD2	STAGE10 maximum value FIFO WORD2
0x260	[15:0]	X	R/W	STAGE10_MAX_WORD3	STAGE10 maximum value FIFO WORD3
0x261	[15:0]	X	R/W	STAGE10_MAX_AVG	STAGE10 average maximum FIFO value
0x262	[15:0]	X	R/W	STAGE10_HIGH_THRESHOLD	STAGE10 high threshold value
0x263	[15:0]	X	R/W	STAGE10_MAX_TEMP	STAGE10 temporary maximum value
0x264	[15:0]	X	R/W	STAGE10_MIN_WORD0	STAGE10 minimum value FIFO WORD0
0x265	[15:0]	X	R/W	STAGE10_MIN_WORD1	STAGE10 minimum value FIFO WORD1
0x266	[15:0]	X	R/W	STAGE10_MIN_WORD2	STAGE10 minimum value FIFO WORD2
0x267	[15:0]	X	R/W	STAGE10_MIN_WORD3	STAGE10 minimum value FIFO WORD3
0x268	[15:0]	X	R/W	STAGE10_MIN_AVG	STAGE10 average minimum FIFO value
0x269	[15:0]	X	R/W	STAGE10_LOW_THRESHOLD	STAGE10 low threshold value
0x26A	[15:0]	X	R/W	STAGE10_MIN_TEMP	STAGE10 temporary minimum value
0x26B	[15:0]	X	R/W	Unused	Set unused register bits = 0

Table 60. STAGE11 Results Registers

Address	Data Bit	Default Value	Type	Name	Description
0x26C	[15:0]	X	R/W	STAGE11_CONV_DATA	STAGE11 CDC 16-bit conversion data (copy of data in STAGE11_CONV_DATA register)
0x26D	[15:0]	X	R/W	STAGE11_FF_WORD0	STAGE11 fast FIFO WORD0
0x26E	[15:0]	X	R/W	STAGE11_FF_WORD1	STAGE11 fast FIFO WORD1
0x26F	[15:0]	X	R/W	STAGE11_FF_WORD2	STAGE11 fast FIFO WORD2
0x270	[15:0]	X	R/W	STAGE11_FF_WORD3	STAGE11 fast FIFO WORD3
0x271	[15:0]	X	R/W	STAGE11_FF_WORD4	STAGE11 fast FIFO WORD4
0x272	[15:0]	X	R/W	STAGE11_FF_WORD5	STAGE11 fast FIFO WORD5
0x273	[15:0]	X	R/W	STAGE11_FF_WORD6	STAGE11 fast FIFO WORD6
0x274	[15:0]	X	R/W	STAGE11_FF_WORD7	STAGE11 fast FIFO WORD7
0x275	[15:0]	X	R/W	STAGE11_SF_WORD0	STAGE11 slow FIFO WORD0
0x276	[15:0]	X	R/W	STAGE11_SF_WORD1	STAGE11 slow FIFO WORD1
0x277	[15:0]	X	R/W	STAGE11_SF_WORD2	STAGE11 slow FIFO WORD2
0x278	[15:0]	X	R/W	STAGE11_SF_WORD3	STAGE11 slow FIFO WORD3
0x279	[15:0]	X	R/W	STAGE11_SF_WORD4	STAGE11 slow FIFO WORD4
0x27A	[15:0]	X	R/W	STAGE11_SF_WORDS5	STAGE11 slow FIFO WORD5
0x27B	[15:0]	X	R/W	STAGE11_SF_WORD6	STAGE11 slow FIFO WORD6
0x27C	[15:0]	X	R/W	STAGE11_SF_WORD7	STAGE11 slow FIFO WORD7
0x27D	[15:0]	X	R/W	STAGE11_SF_AMBIENT	STAGE11 slow FIFO ambient value
0x27E	[15:0]	X	R/W	STAGE11_FF_AVG	STAGE11 fast FIFO average value
0x27F	[15:0]	X	R/W	STAGE11_CDC_WORD0	STAGE11 CDC FIFO WORD0
0x280	[15:0]	X	R/W	STAGE11_CDC_WORD1	STAGE11 CDC FIFO WORD1
0x281	[15:0]	X	R/W	STAGE11_MAX_WORD0	STAGE11 maximum value FIFO WORD0
0x282	[15:0]	X	R/W	STAGE11_MAX_WORD1	STAGE11 maximum value FIFO WORD1
0x283	[15:0]	X	R/W	STAGE11_MAX_WORD2	STAGE11 maximum value FIFO WORD2
0x284	[15:0]	X	R/W	STAGE11_MAX_WORD3	STAGE11 maximum value FIFO WORD3
0x285	[15:0]	X	R/W	STAGE11_MAX_AVG	STAGE11 average maximum FIFO value
0x286	[15:0]	X	R/W	STAGE11_HIGH_THRESHOLD	STAGE11 high threshold value
0x287	[15:0]	X	R/W	STAGE11_MAX_TEMP	STAGE11 temporary maximum value
0x288	[15:0]	X	R/W	STAGE11_MIN_WORD0	STAGE11 minimum value FIFO WORD0
0x289	[15:0]	X	R/W	STAGE11_MIN_WORD1	STAGE11 minimum value FIFO WORD1
0x28A	[15:0]	X	R/W	STAGE11_MIN_WORD2	STAGE11 minimum value FIFO WORD2
0x28B	[15:0]	X	R/W	STAGE11_MIN_WORD3	STAGE11 minimum value FIFO WORD3
0x28C	[15:0]	X	R/W	STAGE11_MIN_AVG	STAGE11 average minimum FIFO value
0x28D	[15:0]	X	R/W	STAGE11_LOW_THRESHOLD	STAGE11 low threshold value
0x28E	[15:0]	X	R/W	STAGE11_MIN_TEMP	STAGE11 temporary minimum value
0x28F	[15:0]	X	R/W	Unused	Set unused register bits = 0

## OUTLINE DIMENSIONS

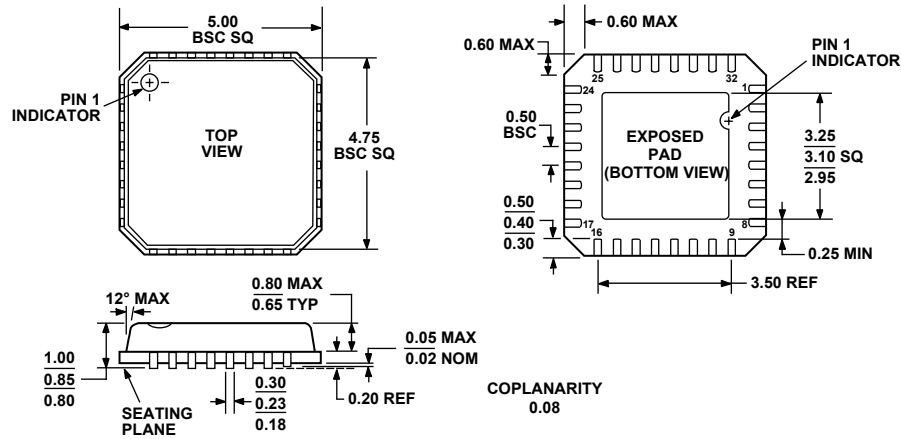

COMPLIANT TO JEDEC STANDARDS MO-220-VHHD-2  
 Figure 60. 32-Lead Frame Chip Scale Package [LF CSP\_VQ]  
 5 mm × 5 mm Very Thin Quad  
 (CP-32-2)  
 Dimensions shown in millimeters

## ORDERING GUIDE

Model	Temperature Range	Serial Interface Description	Package Description	Package Option
AD7142ACPZ-REEL <sup>1</sup>	-40°C to +85°C	SPI Interface	32-Lead LFCSP_VQ	CP-32-2
AD7142ACPZ-500RL7 <sup>1</sup>	-40°C to +85°C	SPI Interface	32-Lead LFCSP_VQ	CP-32-2
AD7142ACPZ-1REEL <sup>1</sup>	-40°C to +85°C	I <sup>2</sup> C Interface	32-Lead LFCSP_VQ	CP-32-2
AD7142ACPZ-1500RL7 <sup>1</sup>	-40°C to +85°C	I <sup>2</sup> C Interface	32-Lead LFCSP_VQ	CP-32-2
EVAL-AD7142EBZ <sup>1</sup>		SPI Interface	Evaluation Board	
EVAL-AD7142-1EBZ <sup>1</sup>		I <sup>2</sup> C Interface	Evaluation Board	

<sup>1</sup> Z = Pb-free part.

**AD7142**

**NOTES**

**NOTES**



**AD7142**

## **NOTES**

Purchase of licensed I<sup>2</sup>C components of Analog Devices or one of its sublicensed Associated Companies conveys a license for the purchaser under the Philips I<sup>2</sup>C Patent Rights to use these components in an I<sup>2</sup>C system, provided that the system conforms to the I<sup>2</sup>C Standard Specification as defined by Philips.