

**0900-0**

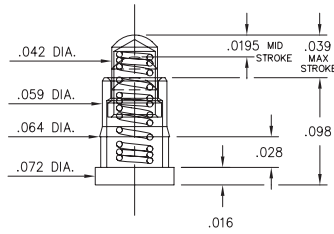

**0900-0-00-00-00-00-11-0**  
Short stroke, Surface mount  
Lowest profile

**0900-1⇒4**

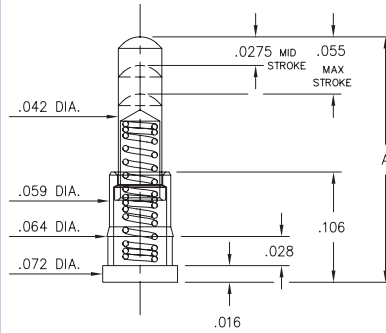

**0900-X-00-00-00-00-11-0**  
Standard stroke, Surface mount  
Low profile

Basic Part Number	Length A
0900-1	.177
0900-2	.197
0900-3	.217
0900-4	.236

**0905**

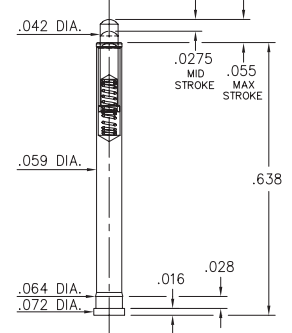

**0905-0-00-00-00-00-11-0**  
Standard stroke, Surface mount  
Highest Profile

**0907-X**

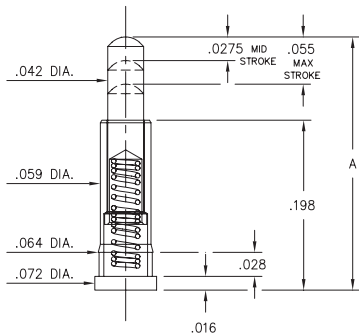

**0907-X-15-20-75-14-11-0**  
Standard stroke, Surface mount  
High profile

Basic Part Number	Length A
0907-0	.255
0907-1	.275
0907-2	.295
0907-3	.315
0907-4	.335
0907-5	.350
0907-6	.370
0907-7	.390
0907-8	.410
0907-9	.430

**0901**

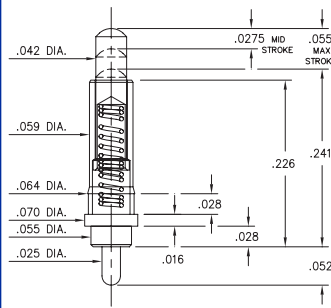

**0901-0-00-00-00-00-11-0**  
Standard stroke  
Solder mount in .027 min. mounting hole

**0914**

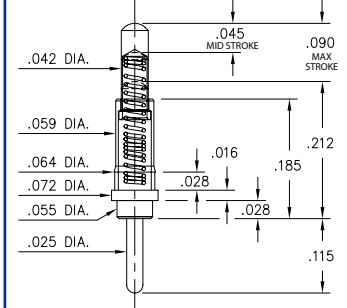

**0914-0-15-20-77-14-11-0**  
Long stroke.  
Solder mount in .027 min. mounting hole

**0922**

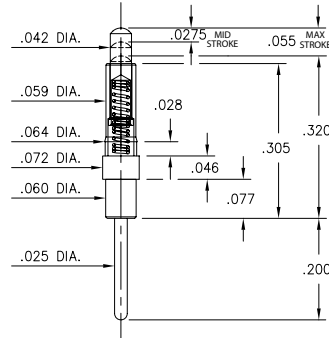

**0922-0-15-20-75-14-11-0**  
Standard stroke  
Solder mount in .027 min. mounting hole

**0906-0**

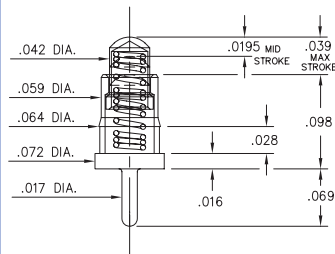

**0906-0-15-20-76-14-11-0**  
Short stroke  
Solder mount in .018 min. mounting hole

**0906-1⇒4**

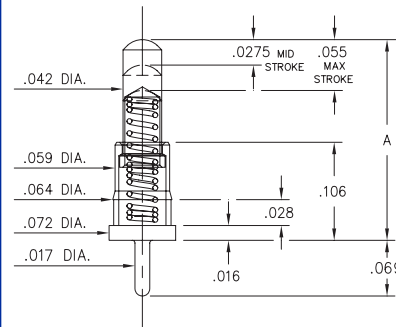

**0906-X-15-20-75-14-11-0**  
Standard stroke  
Solder mount in .018 min. mounting hole

Basic Part Number	Length A
0906-1	.177
0906-2	.197
0906-3	.217
0906-4	.236

**ORDER CODE: 09XX - X - 15 - 20 - 7X - 14 - 11 - 0**

Spring Number

**MATERIAL SPECIFICATIONS:**

- SLEEVE & PLUNGER MATERIAL:** Copper Alloy
- SPRING MATERIAL:** Beryllium Copper
- SLEEVE & PLUNGER FINISH:** 20 μ" Gold over Nickel
- SPRING FINISH:** 10 μ" Gold over Nickel
- DIMENSION IN INCHES:**
- TOLERANCES ON:** LENGTHS: ±.006  
DIAMETERS: ±.002  
ANGLES: ± 2°



**MECHANICAL & ELECTRICAL SPECIFICATIONS:**

- DURABILITY:** 1,000,000 cycles
- CURRENT RATING:** 2A continuous, 3A peak
- CONTACT RESISTANCE:** 20 mΩ max.

SPRING NUMBER	Mid. STROKE	Max. STROKE	FORCE @ Mid. Stroke	Initial Force (Pre-load)
75	.0275	.055	60	25
76	.0195	.039	60	25
77	.045	.090	60	25

75, 76, 77 Springs are not interchangeable