

| DATE | SYM. | DESCRIPTION | DR | CK | REL |
|------|------|-------------|----|----|-----|
|      |      |             |    |    |     |
|      |      |             |    |    |     |
|      |      |             |    |    |     |

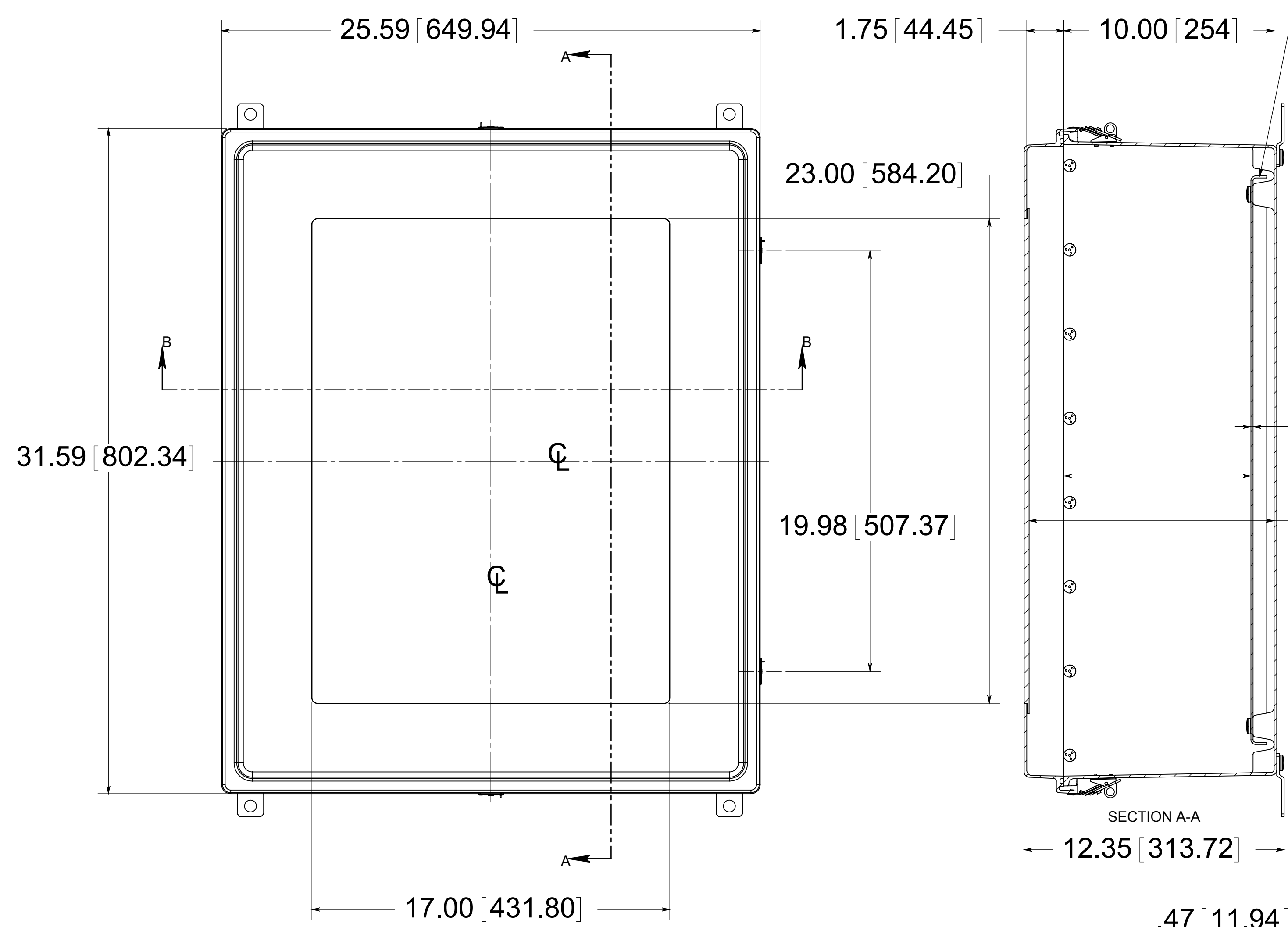

OPTIONAL BACK PANEL SHOWN  
 0.100 [2.54] TH'K- ALUMINUM  
 0.075 [1.91] TH'K- WHITE STEEL & GALVANNEALED  
 0.250 [6.35] TH'K- FIBERGLASS

(4) STAINLESS STEEL MOUNTING FEET  
 (4) EACH 3/8-16 BRASS INSERTS, AND STAINLESS STEEL FEET SCREWS

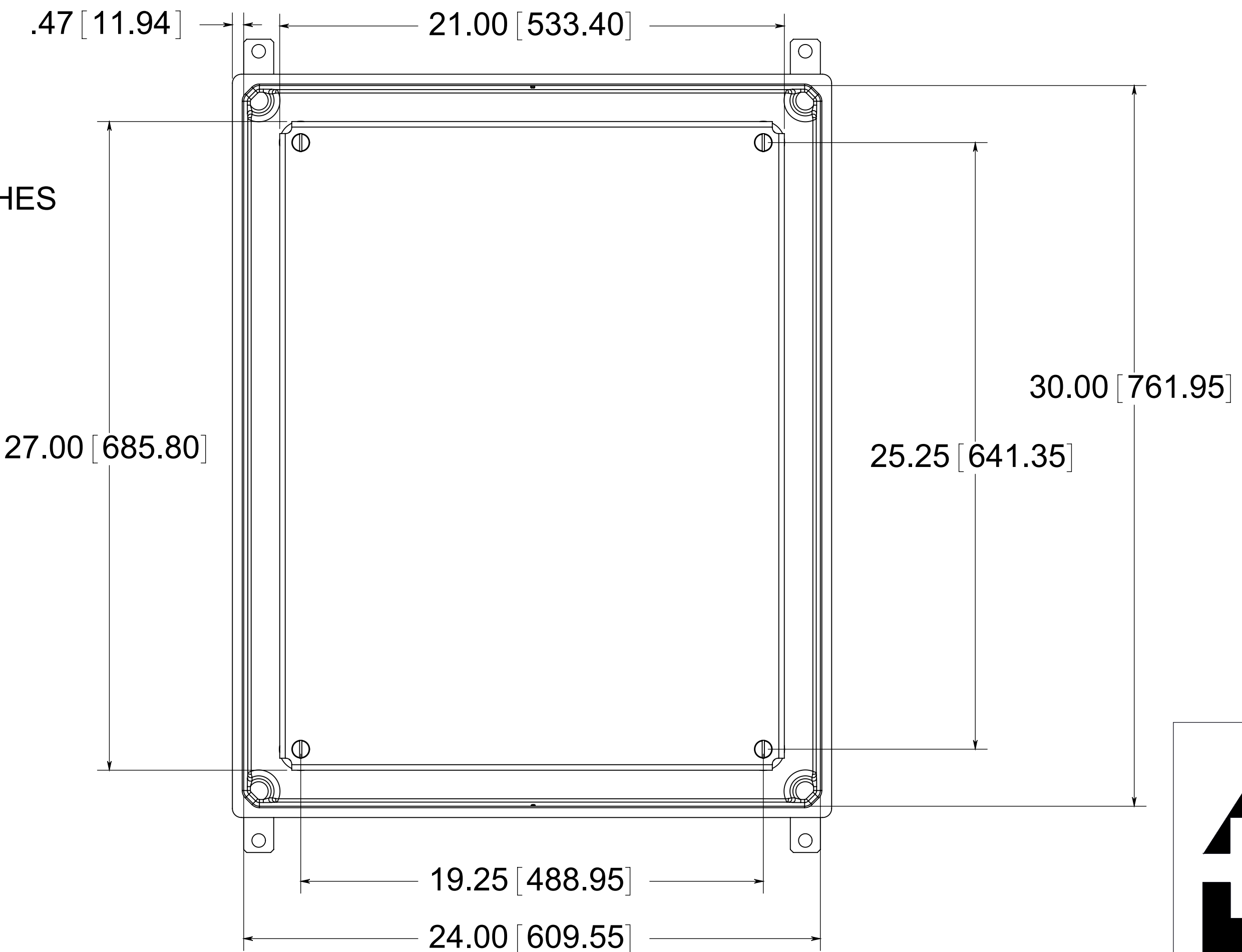
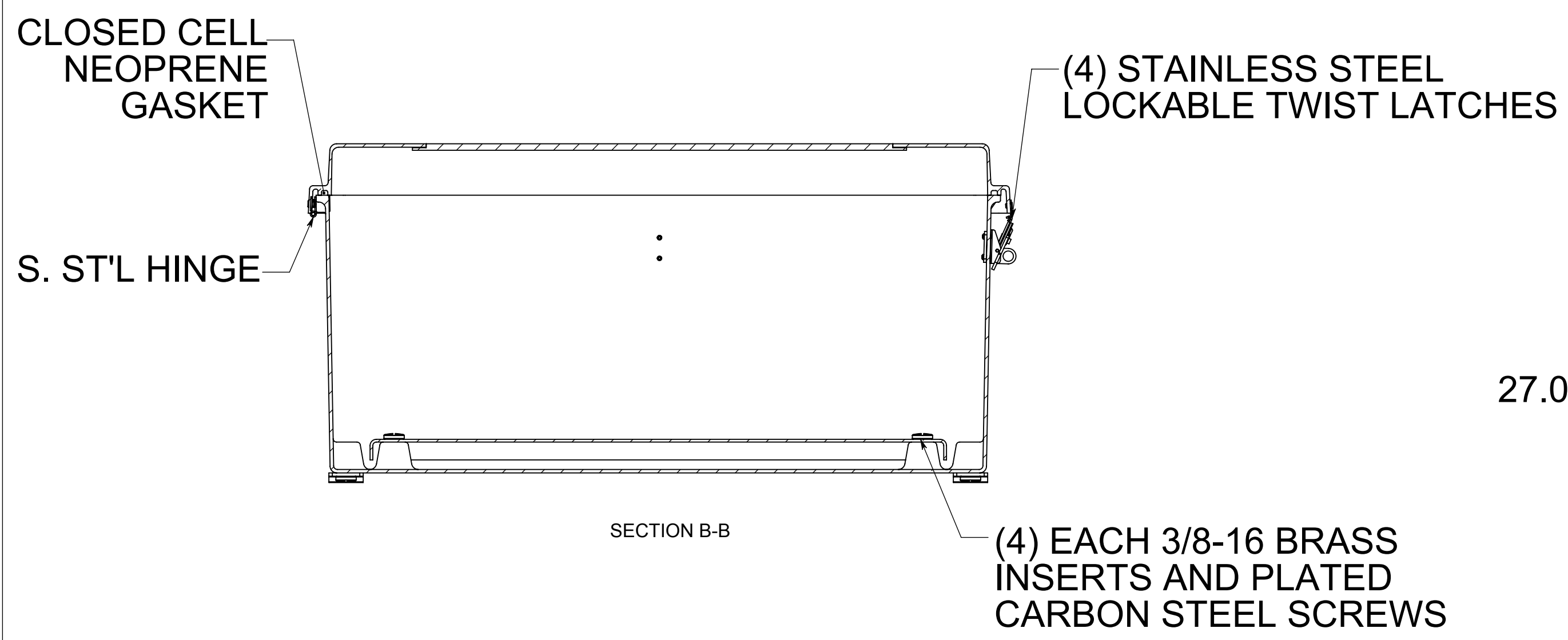
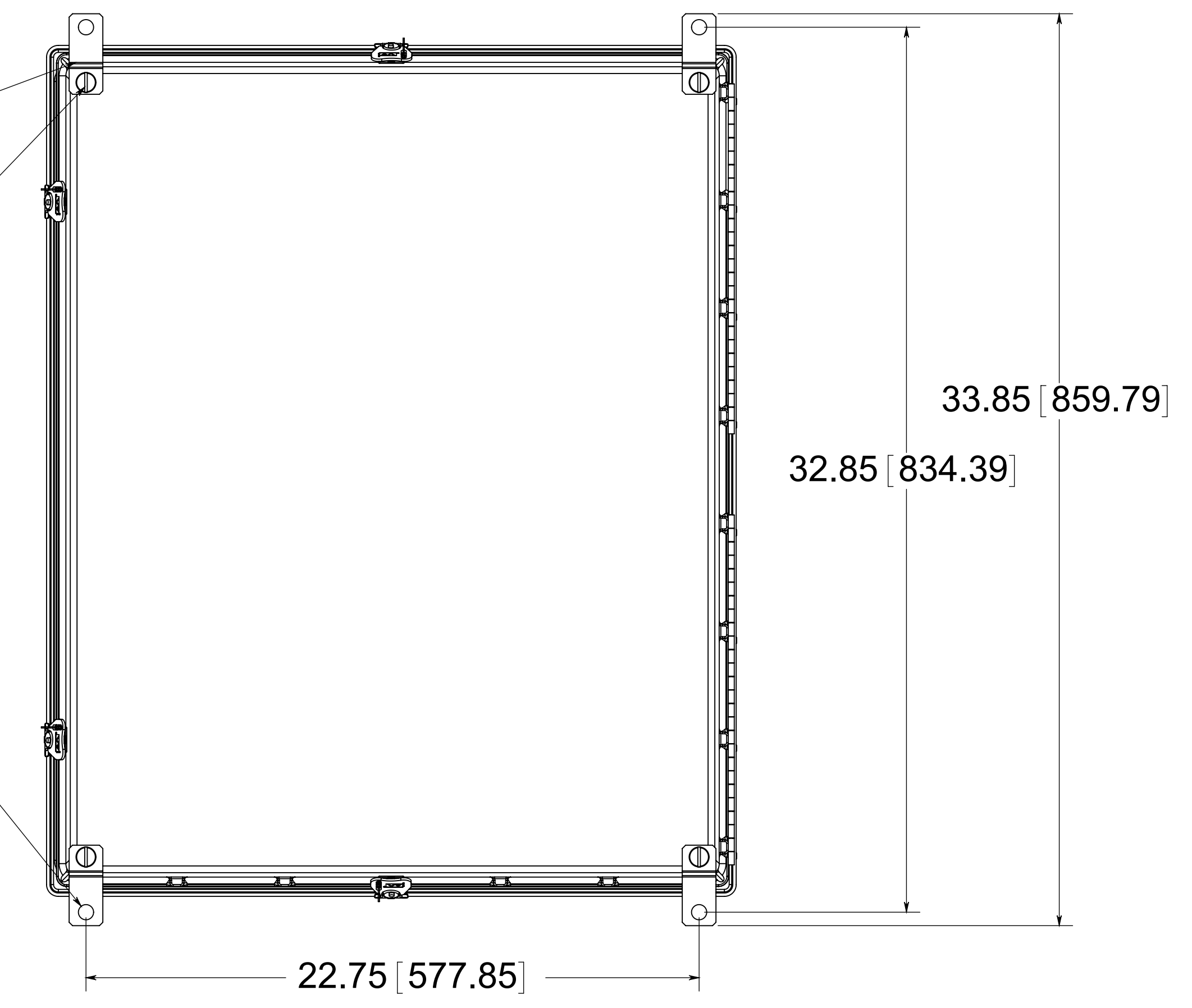

MATERIAL:  
 BOX- COMPRESSION MOLDED FIBERGLASS REINFORCED POLYESTER  
 COVER- COMPRESSION MOLDED FIBERGLASS REINFORCED POLYESTER  
 WINDOW- POLYCARBONATE

**PART No. PJ30240RTW**  
 for more information visit  
[www.hammfg.com](http://www.hammfg.com)  
 Data subject to change without notice  
 Drawing Not to Scale