

RoHS Compliant Product
A suffix of "-C" specifies halogen & lead-free

DESCRIPTION

Planar Schottky barrier diode with an integrated guard ring for stress protection

FEATURES

- Low diode capacitance
- Low forward voltage
- Guard ring protected
- High breakdown voltage

APPLICATION

- Ultra high-speed switching
- Voltage clamping
- Mobile communication ,digital (still) cameras , PDAs and PCMCIA cards

MARKING

S6

PACKAGE INFORMATION

Package	MPQ	Leader Size
WBFBP-02C	10K	7 inch

MAXIMUM RATINGS CHARACTERISTICS (T_A=25°C unless otherwise specified)

Parameter	Symbol	Limits	Unit
DC reverse voltage	V _R	40	V
Forward continuous current	I _F	120	mA
Peak forward surge current @ T _p < 10ms	I _{FSM}	200	mA
Junction, Storage Temperature Range	T _J , T _{STG}	150, -55 ~ 150	°C

ELECTRICAL CHARACTERISTICS (T_A=25°C unless otherwise specified)

Parameters	Symbol	Min.	Typ.	Max.	Unit	Test Conditions
Forward Voltage	V _F	-	-	0.38	V	I _F =1mA
		-	-	0.5		I _F =10mA
		-	-	1		I _F =40mA
Reverse Current ¹	I _R	-	-	1	µA	V _R =30V
		-	-	10		V _R =40V
Diode capacitance	C _d	-	-	5	pF	V _R =0, f=1.0MHz

Note:

1. Pulse Test: t_p=300µs; δ=0.02.

WBFBP-02C

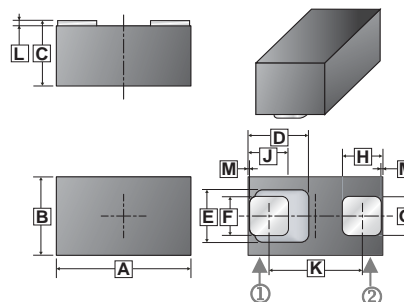

REF.	Millimeter		REF.	Millimeter	
	Min.	Max.		Min.	Max.
A	0.950	1.050	G	0.275	0.325
B	0.550	0.650	H	0.275	0.325
C	0.450	0.550	J	0.275	0.325
D	0.450 REF.		K	0.675	0.725
E	0.400 REF.		L	0.010	0.070
F	0.275	0.325	M	0.010 REF.	

CHARACTERISTIC CURVES

