

SN8P1900 Series

USER'S MANUAL

SN8P1908

SN8P1909

SONiX 8-Bit Micro-Controller

SONiX reserves the right to make change without further notice to any products herein to improve reliability, function or design. SONiX does not assume any liability arising out of the application or use of any product or circuit described herein; neither does it convey any license under its patent rights nor the rights of others. SONiX products are not designed, intended, or authorized for use as components in systems intended, for surgical implant into the body, or other applications intended to support or sustain life, or for any other application in which the failure of the SONiX product could create a situation where personal injury or death may occur. Should Buyer purchase or use SONiX products for any such unintended or unauthorized application. Buyer shall indemnify and hold SONiX and its officers, employees, subsidiaries, affiliates and distributors harmless against all claims, cost, damages, and expenses, and reasonable attorney fees arising out of, directly or indirectly, any claim of personal injury or death associated with such unintended or unauthorized use even if such claim alleges that SONiX was negligent regarding the design or manufacture of the part.

AMENDMENT HISTORY

Version	Date	Description
Pre V0.1	Aug. 2003	Preliminary V0.1 first issue
Pre V0.2	Sep. 2003	<ol style="list-style-type: none"> 1. Rename AVDDR/AVDDCP/VCLD1/AVSS 2. Modify Application circuit. 3. Change AVDDR to 3.8V 4. Port 2 is input only port 5. Change SN8P1908 pin assignment
Pre V0.3	Oct. 2003	<ol style="list-style-type: none"> 1. Modify Register table 2. Change SN8P1908 Feature for 2-differential input 3. Add X register 4. Add ADC note for Stop mode or CPR off can't input signal to Analog channel. 5. Add 80K ADCKS setting
Pre V0.4	Oct. 2003	<ol style="list-style-type: none"> 1. Modify figure 13-1 AO+ to X+ 2. Modify 2's complement Note2. 3. Modify Application circuit 4. Modify Application circuit (AVDDR) 5. Change all GND to VSS
Pre V0.5	Oct. 2003	<ol style="list-style-type: none"> 1. Change all GND to VSS 2. ACM Temp. Coefficient = 50 ppm
Pre V0.6	Oct. 2003	<ol style="list-style-type: none"> 1. Modify Thermometer circuit 2. Modify electrical characteristic 3. Change CP/PGIA/ADC clock calculate 4. FD[1:0] set as "01" all the time 5. Modify Analog demo code
Pre V0.7	Dec. 2003	<ol style="list-style-type: none"> 1. Change ADDR output as 3.8V and relative DC specification 2. Modified DC Spec. About current value. 3. PEDGE Register "01", "10" setting modified.
Pre V0.8	Jan. 2004	<ol style="list-style-type: none"> 1. Bit DRDY is R/W bit, remove Note of DFM 2. Add current note in CPM register for Charge-Pump enabled 3. Connect VLCD1 to VLCD 4. Change Chopper Frequency as 4K 5. Add PGIA output range in DC spec. 6. Modified Application circuit: VLCD and R+/R- 7. Change Charge Pump Frequency as 20K
Pre V0.9	Jul. 2004	<ol style="list-style-type: none"> 1. Modified demo circuit for AVDDCP Cap. Ground to Vss not AVSS. 2. Add 100-ohm resistor in Reset circuit. 3. Modified demo circuit of AVDDCP to Vss, voltage source R+/R- from E+

		4. Add detail description of T0.
V1.0	Jan. 2005	<ol style="list-style-type: none"> 1. Modify SIO descriptions and add SIO timing chart. 2. Modified CPCKS clock table 3. Change ADENB to ADCENB 4. Correct Fig-13-6 AI2-/AI3- 5. Modified I/O diagram 6. Add external low clock RC type oscillator circuit. 7. In Electrical characteristic table: <ol style="list-style-type: none"> a. Change "VDD=3.8V" to "AVDDR=3.8V" b. Add R+/R- minimum differential voltage c. Remove "Band gap Reference" d. Combine "Band gap Reference" operating current into "Charge Pump Regulator" quiescent current. Change I_{QI} from 300uA to 700uA e. Modify some descriptions.
V1.1	Feb. 2005	<ol style="list-style-type: none"> 1. B0MOV M, I, M only supports 0x80~0x87 2. Add note for PUSH/POP only one level. 3. External Reset circuit needs 100-ohm resistance. Figure 6-4
V1.2	Jun. 2005	<ol style="list-style-type: none"> 1. Change FDS setting "01" to "01". 2. Update ADC sample rate to 50 Hz. 3. Complete T0M description. 4. Change Demo code by XB0MOV Marco. 5. Update Fig-13-6/7/8 diagram.
V1.3	Sep. 2005	<ol style="list-style-type: none"> 1. Update Fig-13-6/7/8 diagram.
V1.4	Sep. 2006	<ol style="list-style-type: none"> 1. Modified CPCKS/AMPCKS/ADCKS as write mode register 2. Limit the ADC Linear range as ± 28125 in ADC chapter and elec. Char. 3. Add TC0 wake up from Green mode

Table of Contents

AMENDMENT HISTORY	2
1 PRODUCT OVERVIEW	8
GENERAL DESCRIPTION	8
FEATURES SELECTION TABLE	8
FEATURES.....	9
SYSTEM BLOCK DIAGRAM	11
PIN ASSIGNMENT	12
PIN DESCRIPTIONS	14
PIN CIRCUIT DIAGRAMS	15
2 CODE OPTION TABLE	16
3 ADDRESS SPACES	17
PROGRAM MEMORY (ROM).....	17
DATA MEMORY (RAM)	25
WORKING REGISTERS.....	27
PROGRAM FLAG	30
ACCUMULATOR	31
STACK OPERATIONS.....	32
PROGRAM COUNTER.....	35
4 ADDRESSING MODE	38
OVERVIEW.....	38

5	SYSTEM REGISTER	40
	OVERVIEW.....	40
	SYSTEM REGISTER ARRANGEMENT (BANK 0)	40
6	POWER ON RESET	43
	OVERVIEW.....	43
	EXTERNAL RESET DESCRIPTION.....	44
	LOW VOLTAGE DETECTOR (LVD) DESCRIPTION	45
7	OSCILLATORS.....	46
	OVERVIEW.....	46
	SYSTEM MODE DESCRIPTION	52
	SYSTEM MODE CONTROL	53
	WAKEUP TIME.....	55
8	TIMERS COUNTERS.....	57
	WATCHDOG TIMER (WDT)	57
	BASIC TIMER 0 (T0)	59
	TIMER COUNTER 0 (TC0)	63
	TC0OUT FREQUENCY TABLE	72
	TIMER COUNTER 1 (TC1)	74
	PWM FUNCTION DESCRIPTION	83
9	INTERRUPT.....	87
	OVERVIEW.....	87

INTEN INTERRUPT ENABLE REGISTER	88
INTRQ INTERRUPT REQUEST REGISTER.....	88
INTERRUPT OPERATION DESCRIPTION	89

10 SERIAL INPUT/OUTPUT TRANSCEIVER (SIO)..... 98

OVERVIEW.....	98
SIOM MODE REGISTER.....	100
SIOB DATA BUFFER	101
SIOR REGISTER DESCRIPTION	101
SIO MASTER OPERATING DESCRIPTION	102
SIO SLAVE OPERATING DESCRIPTION.....	106
SIO INTERRUPT OPERATION DESCRIPTION.....	111

11 I/O PORT..... 112

OVERVIEW.....	112
I/O PORT FUNCTION TABLE	113
PULL-UP RESISTOR (P _{NUR}) REGISTER.....	113
I/O PORT MODE	114
THE PORT2 DISCRIPTION.....	115
I/O PORT DATA REGISTER	116

12 LCD DRIVER..... 117

LCDM1 REGISTER	117
LCD TIMING	119
LCD RAM LOCATION	121

13 CHARGE-PUMP, PGIA AND ADC 122

OVERVIEW.....	122
---------------	-----

ANALOG INPUT	122
VOLTAGE CHARGE PUMP / REGULATOR (CPR)	123
PGIA -PROGRAMMABLE GAIN INSTRUMENTATION AMPLIFIER	126
16-BIT ADC	131

14 APPLICATION CIRCUIT..... 137

SCALE (LOAD CELL) APPLICATION CIRCUIT	137
THERMOMETER APPLICATION CIRCUIT	138

15 INSTRUCTION SET TABLE 139

16 ELECTRICAL CHARACTERISTIC 140

ABSOLUTE MAXIMUM RATING	140
ELECTRICAL CHARACTERISTIC	140

17 PACKAGE INFORMATION 142

LQFP64:.....	142
LQFP80.....	144

1 PRODUCT OVERVIEW

GENERAL DESCRIPTION

The SN8P1900 is a RISC-like 8-bit micro-controller utilized CMOS technology and featured with low power consumption and high performance by its unique electronic structure. The device is designed with the excellent IC structure including the program memory up to 8K-word OTP ROM, data memory of 512-bytes RAM, one 8-bit basic timer (T0) with RTC (Real Time Clock) function, two 8-bit timer counters (TC0, TC1), a watchdog timer, six interrupt sources (T0, TC0, TC1, SIO, INT0, INT1), an 5-channel 16-bit ADC converter, Programmable Gain Instrumentation Amplifier, Charge pump, Regulator, two channels PWM output (PWM0, PWM1), two channels buzzer output (BZ0, BZ1), 4-common by 32-segment LCD driver and 8-level stack buffers. There are four oscillator configurations to select for generating system clock, including High/Low Speed crystal, ceramic resonator or cost-saving RC. This device is a dual clock system using a hi-speed crystal for normal mode operation and an external low speed 32.768KHz crystal for slow mode, real time clock and LCD function

FEATURES SELECTION TABLE

CHIP	ROM	RAM	Stack	LCD	Timer			I/O	ADC	PWM Buzzer	SIO	Wakeup Pin no.	Package
					T0	TC0	TC1						
SN8P1908	8K*16	512*8	8	4*24	V	V	V	17	16-bit	2	-	7	LQFP64
SN8P1909	8K*16	512*8	8	4*32	V	V	V	20	16-bit	2	1	7	LQFP80

Table 1-1 Selection table of SN8P1900

FEATURES

➤ SN8P1908

- ◆ **Memory configuration**
OTP ROM size: 8K * 16 bits
RAM size: 512 * 8 bits (bank 0/1/2)
8-levels stack buffer
LCD RAM size: 4*24 bits
- ◆ **I/O pin configuration**
Input only: P0, P2
Bi-directional: P1, P5
P2 shared with LCD segment
Wakeup: P0, P1
Pull-up resistors: P0, P1, P2, P5
External interrupt: P0
- ◆ **Powerful instructions**
Four clocks per instruction cycle
All instructions are one word length.
Most of instructions are 1 cycle only.
Maximum instruction cycle is "2".
JMP instruction jumps to all ROM area.
All ROM area look-up table function (MOVc)
Support hardware multiplier (MUL).
- ◆ **Programmable gain instrumentation amplifier**
Gain option: 1/16/32/64/128
- ◆ **ADC**
16-bit Delta-Sigma ADC with 14-bit noise free
Three ADC channel configuration:
 1. Two fully differential input channels ADC
 2. One differential and two single channels ADC
 3. Four single channels ADC
- ◆ **Five interrupt sources**
Three internal interrupts: T0, TC0, TC1
Two external interrupts: INT0, INT1
- ◆ **1 real-time-clock timer with 0.5/1/2/4 second**
- ◆ **1 eight-bit basic timer with green mode wakeup function**
- ◆ **2 eight-bit timer counters with PWM or buzzer**
- ◆ **Single power supply: 2.4V ~5.5V**
- ◆ **On-chip watchdog timer**
- ◆ **On-chip charge-pump regulator with 3.8V voltage output and 10mA driven current.**
- ◆ **On-chip 1.2V Band gap reference for battery monitor.**
- ◆ **LCD driver:**
1/3 or 1/2 bias voltage.
4 common * 24 segment
- ◆ **Dual clock system offers four operating modes**
External high clock: RC type up to 10 MHz
External high clock: Crystal type up to 16 MHz
External Low clock: Crystal 32768Hz
Normal mode: Both high and low clock active.
Slow mode: Low clock only.
Sleep mode: Both high and low clock stop.
Green mode: Periodical wakeup by timer.
- ◆ **Package**
LQFP64

➤ **SN8P1909**

◆ **Memory configuration**

OTP ROM size: 8K * 16 bits
RAM size: 512 * 8 bits (bank 0/1/2)
8-levels stack buffer
LCD RAM size: 4*32 bits

◆ **I/O pin configuration**

Input only: P0, P2
Bi-directional: P1, P5
P2 shared with LCD segment
Wakeup: P0, P1
Pull-up resistors: P0, P1, P2, P5
External interrupt: P0

◆ **Powerful instructions**

Four clocks per instruction cycle
All instructions are one word length.
Most of instructions are 1 cycle only.
Maximum instruction cycle is "2".
JMP instruction jumps to all ROM area.
All ROM area look-up table function (MOVC)
Support hardware multiplier (MUL).

◆ **Programmable gain instrumentation amplifier**
Gain option: 1/16/32/64/128

◆ **ADC**

16-bit Delta-Sigma ADC with 14-bit noise free
Three ADC channel configuration:
1. Three fully differential input channels ADC
2. Two differential and two single channels ADC
3. One differential and four single channels ADC

◆ **Six interrupt sources**

Four internal interrupts: T0, TC0, TC1, SIO
Two external interrupts: INT0, INT1

- ◆ **1 real-time-clock timer with 0.5/1/2/4 second**
- ◆ **1 eight-bit basic timer with green mode wakeup function**
- ◆ **2 eight-bit timer counters with PWM or buzzer**

◆ **Single power supply: 2.4V ~5.5V**

◆ **On-chip watchdog timer**

◆ **On-chip charge-pump regulator with 3.8V voltage output and 10mA drive current.**

◆ **On-chip 1.2V Band gap reference for battery monitor.**

◆ **SIO function**

◆ **LCD driver:**

1/3 or 1/2 bias voltage.
4 common * 32 segment

◆ **Dual clock system offers four operating modes**

External high clock: RC type up to 10 MHz
External high clock: Crystal type up to 16 MHz
External Low clock: Crystal 32768Hz
Normal mode: Both high and low clock active.
Slow mode: Low clock only.
Sleep mode: Both high and low clock stop.
Green mode: Periodical wakeup by timer.

◆ **Package**

LQFP80

SYSTEM BLOCK DIAGRAM

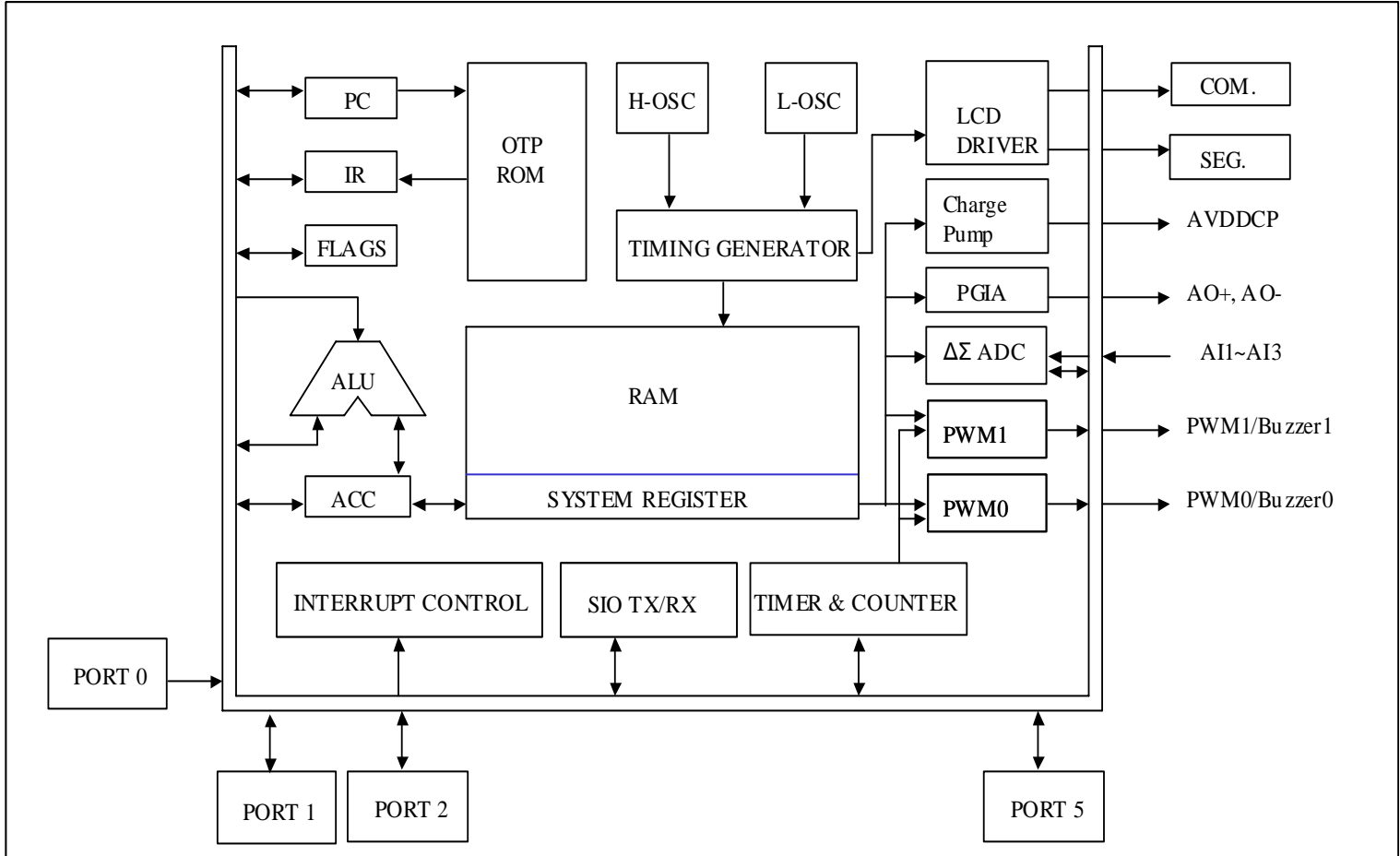
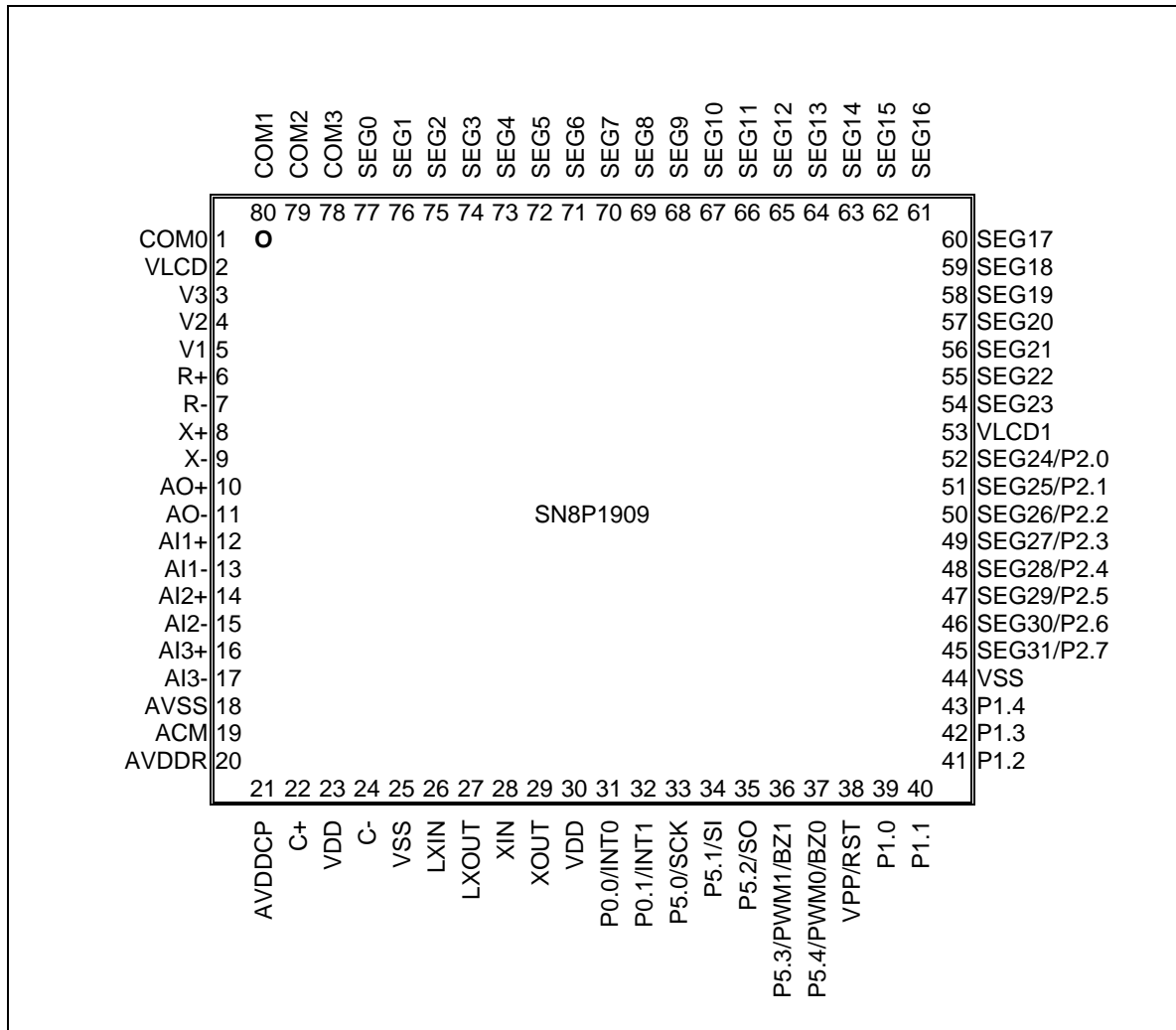

Figure 1-1 Simplified system block diagram

SN8P1909 (LQFP80)



PIN DESCRIPTIONS

PIN NAME	TYPE	DESCRIPTION
VDD, VSS,	P	Power supply input pins for digital/analog circuit.
VLCD1	P	Power supply of P2.0 ~ P2.7/ SEG24~31. connect to VLCD
VLCD	P	Power supply of LCD
V1~V3	P	LCD bias voltage input
AVDDR	P	Regulator power output pin, Voltage=3.8V Maximum output current=10mA.
AVSS	P	Regulator Analog Ground.
AVDDCP	P	Charge Pump Voltage output. (Connect a 2.2uF or higher capacitor to ground)
ACM	P	Analog common voltage output, 1.2V
R+	AI	Positive ADC reference voltage input
R-	AI	Negative ADC reference voltage input
X+	AI	Positive ADC differential input
X-	AI	Negative ADC differential input
AO+	AO	Positive amplifier output
AO-	AO	Negative amplifier output
AI1+	AI	Positive analog input channel 1
AI1-	AI	Negative analog input channel 1
AI2+	AI	Positive analog input channel 2
AI2-	AI	Negative analog input channel 2
AI3+	AI	Positive analog input channel 3
AI3-	AI	Negative analog input channel 3
C+	A	Positive capacitor terminal for charge pump regulator
C-	A	Negative capacitor terminal for charge pump regulator
VPP/ RST	P, I	OTP ROM programming pin. System reset input pin. Schmitt trigger structure, active "low", normal stay to "high".
XIN, XOUT	I, O	External High clock oscillator pins. RC mode from XIN.
LXIN, LXOUT	I, O	External Low clock oscillator pins. RC mode from LXIN.
P0.0 / INT0	I	Port 0.0 and shared with INT0 trigger pin (Schmitt trigger) / Built-in pull-up resistors.
P0.1 / INT1	I	Port 0.1 and shared with INT1 trigger pin (Schmitt trigger) / Built-in pull-up resistors.
P1.0~P1.4	I/O	Port 1.0~Port 1.4 bi-direction pins / wakeup pins/ Built-in pull-up resistors.
P2.0 ~ P2.7	I	Port 2.0~Port 2.7 Input port/ built-in pull-up register and shared with LCD SEG24~SEG31.
P5.0 / SCK	I/O	Port 5.0 bi-direction pin and SIO's clock input/output / Built-in pull-up resistors.
P5.1 / SI	I/O	Port 5.1 bi-direction pin and SIO's data input / Built-in pull-up resistors.
P5.2 / SO	I/O	Port 5.2 bi-direction pin and SIO's data output / Built-in pull-up resistors.
P5.3 / BZ1 / PWM1	I/O	Port 5.3 bi-direction pin, TC1 signal output pin for buzzer or PWM1 output pin. Built-in pull-up resistors.
P5.4 / BZ0 / PWM0	I/O	Port 5.4 bi-direction pin, TC0 signal output pin for buzzer or PWM0 output pin. Built-in pull-up resistors.
COM [3:0]	O	LCD driver common port
SEG0 ~ SEG31	O	LCD driver segment pins.

Table 1-2 SN8P1900 pin description

PIN CIRCUIT DIAGRAMS

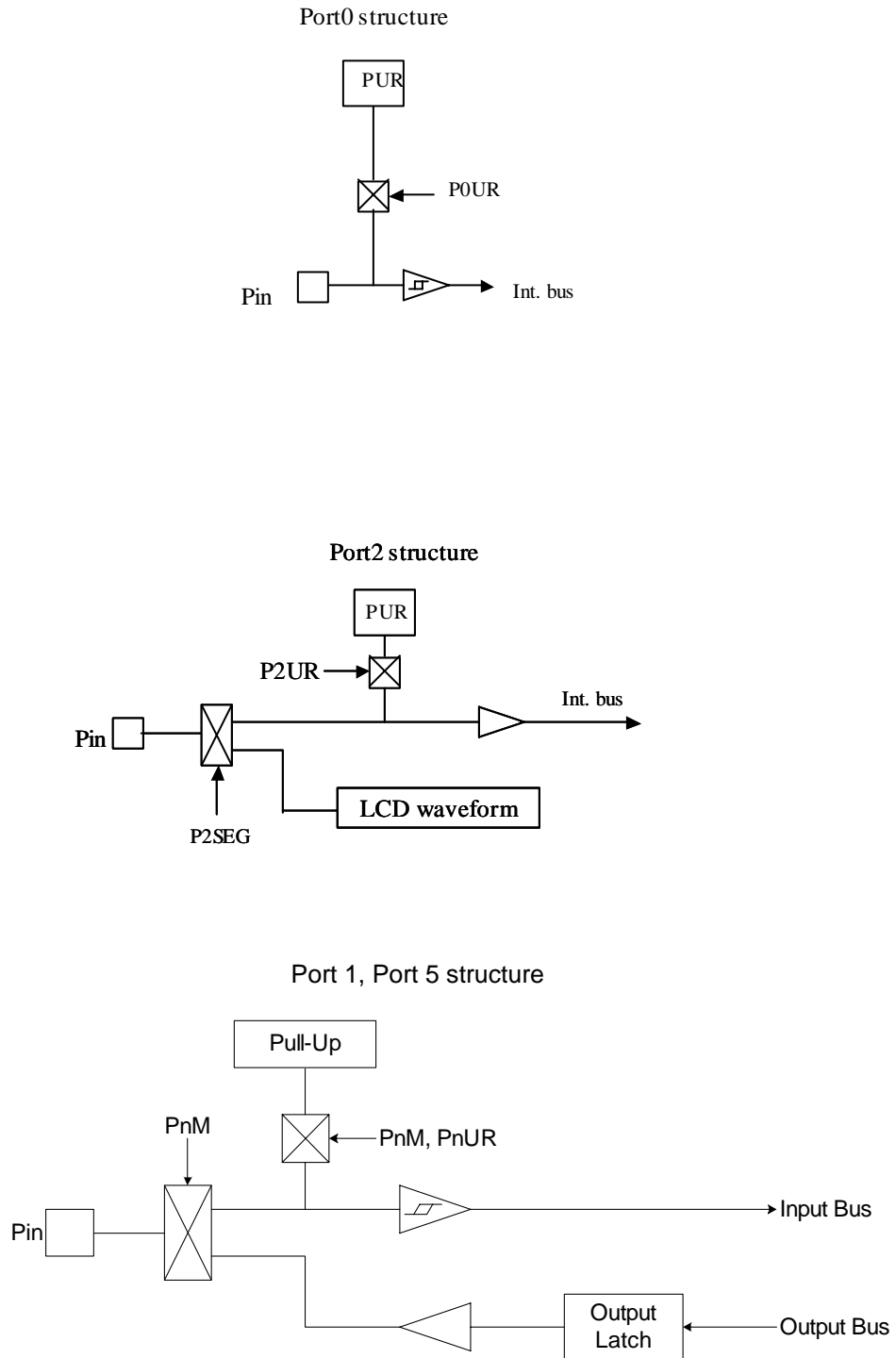

Figure 1-2. Pin Circuit Diagram

2 CODE OPTION TABLE

Code Option	Content	Function Description
High_Clk	RC	Low cost RC for external high clock oscillator
	32K X'tal	Low frequency, power saving crystal (e.g. 32.768K) for external high clock oscillator
	12M X'tal	High speed crystal /resonator (e.g. 12M) for external high clock oscillator
	4M X'tal	Standard crystal /resonator (e.g. 3.58M) for external high clock oscillator
High_Clk / 2	Enable	External high clock divided by two, $F_{OSC} = \text{high clock} / 2$
	Disable	$F_{OSC} = \text{high clock}$
OSG	Enable	Enable Oscillator Safe Guard function
	Disable	Disable Oscillator Safe Guard function
Watch_Dog	Enable	Enable Watchdog function
	Disable	Disable Watchdog function
Security	Enable	Enable ROM code Security function
	Disable	Disable ROM code Security function
TC0_Count	8-bit	TC0 as 8-bit counter.
	6-bit	TC0 as 6-bit counter.
	5-bit	TC0 as 5-bit counter.
	4-bit	TC0 as 4-bit counter.
TC1_Count	8-bit	TC1 as 8-bit counter.
	6-bit	TC1 as 6-bit counter.
	5-bit	TC1 as 5-bit counter.
	4-bit	TC1 as 4-bit counter.
Noise Filter	Enable	Enable Noise Filter function to enhance EMI performance
	Disable	Disable Noise Filter function
INT_16K_RC	Always_ON	Force Watch Dog Timer clock source come from INT 16K RC. Also INT 16K RC never stop both in power down and green mode that means Watch Dog Timer will always enable both in power down and green mode.
	By_CPUM	Enable or Disable internal 16K(@ 3V) RC clock by CPUM register
Low Power	Enable	Enable Low Power function to save Operating current
	Disable	Disable Low Power function

Table 2-1. Code Option Table of SN8P1900

Notice:

- **In high noisy environment, enable “Noise Filter”, “OSG” and disable “Low Power” is strongly recommended.**
- **The side effect is to increase the lowest valid working voltage level if enable “Noise Filter” or “OSG” or “Low Power” code option.**
- **Enable “Low Power” option will reduce operating current except in 32K X'tal or slow mode.**
- **If users select “32K X'tal” in “High_Clk” option, assembler will force “OSG” to be enabled.**
- **If users select “RC” in “High_Clk” option, assembler will force “High_Clk / 2” to be enabled.**

3

ADDRESS SPACES

PROGRAM MEMORY (ROM)

OVERVIEW

ROM Maps for SN8P1900 devices provide 8K x 16 OTP memory that programmable by user. The SN8P1900 program memory is able to fetch instructions through 13-bit wide PC (Program Counter) and can look up ROM data by using ROM code registers (R, X, Y, Z). In standard configuration, the device's 8192 * 16-bit program memory has four areas:

- 1-word reset vector addresses
- 1-word Interrupt vector addresses
- 5-words reserved area
- 8K words general purpose area

All of the program memory is partitioned into two coding areas, located from 0000H to 0008H and from 0009H to 0FFEH. Former area is assigned for executing reset vector and interrupt vector. The later area is for storing instruction's OP-code and look-up table's data. User's program is in the last area (0010H~1FFEH).

ROM		
0000H	Reset vector	User reset vector
0001H	General purpose area	Jump to user start address
0002H		Jump to user start address
0003H		Jump to user start address
0004H	Reserved	
0005H		
0006H		
0007H		
0008H	Interrupt vector	User interrupt vector
0009H	General purpose area	User program
.		
000FH		
0010H		
0011H		
.		
1FFEH		End of user program
1FFFH	Reserved	

Figure 3-1. ROM Address Structure

USER RESET VECTOR ADDRESS (0000H)

A 1-word vector address area is used to execute system reset. After power-on reset or watchdog timer overflow reset, chip restarts the program from address 0000h and all system registers will be set as default values. The following example shows the way to define the reset vector in the program memory.

⇒ **Example: After power on reset, external reset active or reset by watchdog timer overflow.**

```

ORG      0          ; 0000H
JMP      START    ; Jump to user program address.
.          ; 0004H ~ 0007H are reserved

START:    ORG      10H          ; 0010H, The head of user program.
.          ; User program
.
.
ENDP                    ; End of program

```

INTERRUPT VECTOR ADDRESS (0008H)

A 1-word vector address area is used to execute interrupt request. If any interrupt service is executed, the program counter (PC) value is stored in stack buffer and points to 0008h of program memory to execute the vectored interrupt. Users have to define the interrupt vector. The following example shows the way to define the interrupt vector in the program memory.

⇒ **Example 1: This demo program includes interrupt service routine and the user program is behind the interrupt service routine.**

```

ORG      0          ; 0000H
JMP      START    ; Jump to user program address.
.          ; 0001H ~ 0007H are reserved

ORG      8          ; Interrupt service routine
BOXCH    A, ACCBUF ; BOXCH doesn't change C, Z flag
PUSH                    ; Push 80H ~ 87H system registers
.
.
POP                    ; Pop 80H ~ 87H system registers
BOXCH    A, ACCBUF
RETI                    ; End of interrupt service routine

START:    ; The head of user program.
.          ; User program
.
.
JMP      START    ; End of user program

ENDP                    ; End of program

```

- ⇒ Example 2: The demo program includes interrupt service routine and the address of interrupt service routine is in a special address of general-purpose area.

```

    ORG    0                ; 0000H
    JMP    START           ; Jump to user program address.
    .                ; 0001H ~ 0007H are reserved

    ORG    08
    JMP    MY_IRQ          ; 0008H, Jump to interrupt service routine address

START:
    ORG    10H            ; 0010H, The head of user program.
    .                ; User program
    .
    .
    JMP    START          ; End of user program

MY_IRQ:
    BOXCH A, ACCBUF       ; Label of interrupt service routine
    PUSH                     ; BOXCH doesn't change C, Z flag
    .                ; Push 80H ~ 87H system registers
    .
    .
    POP                     ; Pop 80H ~ 87H system registers
    BOXCH A, ACCBUF
    RETI                   ; End of interrupt service routine

    ENDP                  ; End of program

```

- Remark: it is easy to get the rules of SONiX program from demo programs given above. These points are as following.

1. The address 0000H is a "JMP" instruction to make the program go to general-purpose ROM area. The 0004H~0007H are reserved. Users have to skip 0004H~0007H addresses. It is very important and necessary.

2. The interrupt vector located at 0008H. Users can put the whole interrupt service routine from 0008H (Example1) or to put a "JMP" instruction in 0008H then place the interrupt service routine in other general-purpose ROM area (Example2) to get modularized coding style.

CHECKSUM CALCULATION

The ROM addresses 0004H~0007H and last address are reserved area. User should avoid these addresses (0004H~0007H and last address) when calculate the Checksum value.

➔ **Example:**

The demo program shows how to avoid 0004H~0007H when calculated Checksum from 00H to the end of user's code

```

MOV      A, #END_USER_CODE$L
B0MOV   END_ADDR1,A           ; save low end address to end_addr1
MOV     A,#END_USER_CODE$M
B0MOV   END_ADDR2,A           ; save middle end address to end_addr2
CLR     Y                       ; set Y to 00H
CLR     Z                       ; set Z to 00H

@@:
CALL    YZ_CHECK              ; call function of check yz value
MOVC
B0BSET  FC                     ;clear C flag
ADD     DATA1,A              ;add A to Data1
MOV     A,R
ADC     DATA2,A              ;add R to Data2
JMP     END_CHECK             ;check if the YZ address = the end of code

AAA:
INCMS   Z                      ;Z=Z+1
JMP     @B                     ;if Z!= 00H calculate to next address
JMP     Y_ADD_1                ;if Z=00H increase Y

END_CHECK:
MOV     A,END_ADDR1
CMPRS   A,Z                    ;check if Z = low end address
JMP     AAA                    ;if Not jump to checksum calculate
MOV     A,END_ADDR2
CMPRS   A,Y                    ;if Yes, check if Y = middle end address
JMP     AAA                    ;if Not jump to checksum calculate
JMP     CHECKSUM_END           ;if Yes checksum calculated is done.
YZ_CHECK:
MOV     A,#04H
CMPRS   A,Z                    ;check if Z=04H
RET     ;if Not return to checksum calculate
MOV     A,#00H
CMPRS   A,Y                    ;if Yes, check if Y=00H
RET     ;if Not return to checksum calculate
INCMS   Z                      ;if Yes, increase 4 to Z
INCMS   Z
INCMS   Z
INCMS   Z
RET     ;set YZ=0008H then return

Y_ADD_1:
INCMS   Y                      ;increase Y
NOP
JMP     @B                     ;jump to checksum calculate

CHECKSUM_END:
.....
.....

END_USER_CODE:                ; Label of program end

```

GENERAL PURPOSE PROGRAM MEMORY AREA

The 8174-word at ROM locations 0010H~1FFEh is used as general-purpose memory. The area stored instruction's op-code and look-up table data. The SN8P1900 includes jump table function by using program counter (PC) and look-up table function by using ROM code registers (R, X, Y, Z).

The boundary of program memory is separated by the high-byte program counter (PCH) every 100H. In jump table function and look-up table function, the program counter can't leap over the boundary by program counter automatically. Users need to modify the PCH value to "PCH+1" as the PCL overflow (from 0FFH to 000H).

LOOK-UP TABLE DESCRIPTION

In the ROM's data look-up function, the X-register points to the highest 8-bit, Y-register to the middle 8-bit and Z-register to the lowest 8-bit data of ROM address. After MOVC instruction executed, the low-byte data of ROM stores in ACC and high-byte data stores in R register.

⇒ **Example: To look-up the ROM data located "TABLE1".**

```

        B0MOV    Y, #TABLE1$M    ; To set look-up table1's middle address
        B0MOV    Z, #TABLE1$L    ; To set look-up table1's low address.
        MOVC     ; To look-up data, R = 00H, ACC = 35H
        ;
        ; Increment the index address for next address
        INCMS    Z               ; Z+1
        JMP      @F              ; Not overflow
        INCMS    Y               ; Z overflow (FFH → 00), → Y=Y+1
        NOP      ; Not overflow
        ;
@@:     MOVC     ; To look-up data, R = 51H, ACC = 05H.
        ;
TABLE1: DW      0035H           ; To define a word (16 bits) data.
        DW      5105H           ; "
        DW      2012H           ; "
        ;

```

➤ **CAUTION:** The Y-register can't increase automatically if Z-register cross boundary from 0xFF to 0x00. Therefore, user must take care such situation to avoid loop-up table errors. If Z-register overflows, Y-register must be added by one. The following INC_YZ macro shows a simple method to process Y and Z registers automatically.

➤ **Note:** Because the program counter (PC) is only 13-bit, the X register is useless in the application. Users can omit "B0MOV X, #TABLE1\$H". SONiX ICE support more larger program memory addressing capability. So make sure X register is "0" to avoid unpredicted error in loop-up table operation.

⇒ **Example: INC_YZ Macro**

```

INC_YZ    MACRO
        INCMS    Z               ; Z+1
        JMP      @F              ; Not overflow

        INCMS    Y               ; Y+1
        NOP      ; Not overflow
@@:
        ENDM

```

The other coding style of look-up table is to add Y or Z index register by accumulator. Be careful if carry happens. Refer the following example for detailed information:

➤ **Example: Increase Y and Z register by B0ADD/ADD instruction**

```
B0MOV    Y, #TABLE1$M    ; To set look-up table's middle address.
B0MOV    Z, #TABLE1$L    ; To set look-up table's low address.
```

```
B0MOV    A, BUF          ; Z = Z + BUF.
B0ADD    Z, A
```

```
B0BTS1   FC              ; Check the carry flag.
JMP      GETDATA        ; FC = 0
INCMS    Y               ; FC = 1. Y+1.
NOP
```

GETDATA:

```
MOV      ;
MOV      ; To look-up data. If BUF = 0, data is 0x0035
MOV      ; If BUF = 1, data is 0x5105
MOV      ; If BUF = 2, data is 0x2012
```

TABLE1:

```
.
DW      .                ; To define a word (16 bits) data.
DW      0035H            ;
DW      5105H            ;
DW      2012H            ;
```

JUMP TABLE DESCRIPTION

The jump table operation is one of multi-address jumping function. Add low-byte program counter (PCL) and ACC value to get a new PCL. The new program counter (PC) points to a series jump instructions as a listing table. The way is easy to make a multi-branch program.

When carry flag occurs after executing of "ADD PCL, A", it will not affect PCH register. Users have to check if the jump table leaps over the ROM page boundary or the listing file generated by SONiX assembler. If the jump table leaps over the ROM page boundary (e.g. from xxFFH to xx00H), move the jump table to the top of next program memory page (xx00H). **Here one page mean 256 words.**

⇒ **Example : If PC = 0323H (PCH = 03H, PCL = 23H)**

```

ORG      0X0100      ; The jump table is from the head of the ROM boundary

B0ADD    PCL, A      ; PCL = PCL + ACC, the PCH can't be changed.
JMP      A0POINT    ; ACC = 0, jump to A0POINT
JMP      A1POINT    ; ACC = 1, jump to A1POINT
JMP      A2POINT    ; ACC = 2, jump to A2POINT
JMP      A3POINT    ; ACC = 3, jump to A3POINT

```

In following example, the jump table starts at 0x00FD. When executing "B0ADD PCL, A", ACC = 0 or 1, the jump table points to the right address. If the ACC is larger than 1 will cause error because PCH doesn't increase one automatically. We can see the PCL = 0 when ACC = 2 but the PCH still keep in 0. The program counter (PC) will point to a wrong address 0x0000 and crash system operation. It is important to check whether the jump table crosses over the boundary (xxFFH to xx00H). A good coding style is to put the jump table at the start of ROM boundary (e.g. 0100H).

⇒ **Example: Errors occurs if jump table's range over ROM boundary.**

```

ROM Address
.
.
.
0X00FD    B0ADD    PCL, A      ; PCL = PCL + ACC, the PCH can't be changed.
0X00FE    JMP      A0POINT    ; ACC = 0
0X00FF    JMP      A1POINT    ; ACC = 1
0X0100    JMP      A2POINT    ; ACC = 2 ← jump table cross boundary here
0X0101    JMP      A3POINT    ; ACC = 3
.
.
.

```

SONiX provides a macro for safe jump table function. This macro checks the ROM boundary and move the jump table to the right position. The side effect of this macro is maybe wasting some ROM size. Notice the maximum jump table number for this macro is limited to 254.

```

@JMP_A    MACRO    VAL
IF        (($+1) !& 0XFF00) != (($+(VAL)) !& 0XFF00)
JMP      ($ | 0XFF)
ORG      ($ | 0XFF)
ENDIF
ADD      PCL, A
ENDM

```

➤ **Note: "VAL" is the number of the jump table listing number.**

➔ Example: “@JMP_A” application in SONIX macro file called “MACRO3.H”.

```
B0MOV    A, BUF0      ; "BUF0" is from 0 to 4.
@JMP_A   5            ; The number of the jump table listing is five.
JMP      A0POINT     ; If ACC = 0, jump to A0POINT
JMP      A1POINT     ; ACC = 1, jump to A1POINT
JMP      A2POINT     ; ACC = 2, jump to A2POINT
JMP      A3POINT     ; ACC = 3, jump to A3POINT
JMP      A4POINT     ; ACC = 4, jump to A4POINT
```

If the jump table position is from 00FDH to 0101H, the “@JMP_A” macro will make the jump table to start from 0100h.

DATA MEMORY (RAM)

OVERVIEW

The SN8P1900 has internally built-in data memory up to 512 bytes for storing general-purpose data and featured with LCD memory space up to 128 locations (4*32 bits) for displaying.

- 512 * 8-bit general purpose area
- 128 * 8-bit system register area
- 4*32* 8-bit LCD memory space

These memories are separated into bank 0~3 and bank 15. The user can program RBANK register of RAM bank selection bit to access all data in any of the five RAM banks. The bank 0~3 use the first 128-byte location assigned as general-purpose area, and the remaining 128-byte of bank 0 as system register. The bank 15 is LCD RAM area designed for storing LCD display data.

		RAM location	
BANK 0	000h	General purpose area	; 000h~07Fh of Bank 0 = To store general purpose data (128 bytes).
	07Fh	.	
	080h	System register	; 080h~0FFh of Bank 0 = To store system registers (128 bytes).
	0FFh	End of bank 0 area	
BANK 1	100h	General purpose area	; Bank 1 = To store general-purpose data.
	1FFh	End of bank 1 area	; Bank 1 had 256 bytes RAMs.
BANK 2	200h	“	; Bank 2 = To store general-purpose data.
	27Fh	“	
	300h	“	; “
	380h	“	; “
	F00h	LCD RAM area	; Bank 15 = To store LCD display data (32 bytes).
BANK 15	F1Fh	End of LCD Ram	

Figure 3-2 RAM map of SN8P1900

- **Note1:** The undefined locations of system register area are logic “high” after executing read instruction “MOV A, M”.
- **Note2:** The lower 32 locations of bank15 are used to store LCD display data and the other locations are reserved. The RAM of LCD data area only use lowest 4-bit. The highest 4-bit are undefined.

RAM BANK SELECTION

The RBANK is an 4-bit register located at 87H in RAM bank 0. The user can access RAM data by using this register pointing to working RAM bank for ACC to read/write RAM data.

RBANK initial value = XXXX 0000

087H	Bit 7	Bit 6	Bit 5	Bit 4	Bit 3	Bit 2	Bit 1	Bit 0
RBANK	-	-	-	-	RBNKS3	RBNKS2	RBNKS1	RBNKS0
	-	-	-	-	R/W	R/W	R/W	R/W

RBNK_N: RAM bank selecting control bit. 0 = bank 0, 1 = bank 1.

➔ **Example: RAM bank selecting.**

```

; BANK 0
    CLR    RBANK
    .
; BANK 1
    MOV    A, #1
    B0MOV RBANK, A
    .
    
```

➤ **Note: “B0MOV” instruction can access the RAM of bank 0 in any RBANK situation.**

➔ **Example: Access bank 0 data when RBANK points to bank 1.**

```

; BANK 1
    B0BSET RBNKS0 ; Get into RAM bank 1
    B0MOV  A, BUF0 ; Read BUF0 data. BUF0 is in RAM bank0.
    MOV    BUF1, A ; Write BUF0 data to BUF1. BUF1 is in RAM bank1.
    .
    .
    MOV    A, BUF1 ; Read BUF1 data and store in ACC.
    B0MOV  BUF0, A ; Write ACC data to BUF0.
    .
    
```

When RBANK points to bank 1, using “B0MOV” instruction is an easy way to access RAM bank 0 data. User can make a habit to read/write system register (0087H~00FFH). Then user can access system registers without switching RAM bank.

➔ **Example: To Access the system registers when RBANK points to bank 1.**

```

; BANK 1
    B0BSET RBNKS0 ; Get into RAM bank 1
    .
    MOV    A, #0FFH ; Set all pins of P1 to be logic high.
    B0MOV  P1, A
    .
    B0MOV  A, P0 ; Read P0 data and store into BUF1 of RAM bank 1.
    MOV    BUF1, A
    .
    
```

WORKING REGISTERS

The locations 80H to 86H of RAM bank 0 stores the specially defined registers such as register H, L, R, X, Y, Z and PFLAG, respectively shown in the following table. These registers can be the general purpose of working buffer and also use to access ROM's and RAM's data. For instance, all of the ROM's table can be looked-up with R, X, Y and Z registers. The data of RAM memory can be indirectly accessed with H, L, Y and Z registers.

	80H	81H	82H	83H	84H	85H	86H
RAM	L	H	R	Z	Y	X	PFLAG
	R/W	R/W	R/W	R/W	R/W	R/W	R/W

H, L REGISTERS

The H-register and L-register are 8-bit register with two major functions. One is as working register and the other is to be data pointer to access RAM's data. The @HL located at address E6H in bank 0 is indirect data buffer. H and L register addresses RAM location in order to read/write data through @HL. The Lower 4-bit of H register is pointed to RAM bank number and L register is pointed to RAM address number, respectively. The higher 4-bit data of H register is truncated in RAM indirectly access mode.

H initial value = 0000 0000

081H	Bit 7	Bit 6	Bit 5	Bit 4	Bit 3	Bit 2	Bit 1	Bit 0
H	HBIT7	HBIT6	HBIT5	HBIT4	HBIT3	HBIT2	HBIT1	HBIT0
	R/W	R/W	R/W	R/W	R/W	R/W	R/W	R/W

L initial value = 0000 0000

080H	Bit 7	Bit 6	Bit 5	Bit 4	Bit 3	Bit 2	Bit 1	Bit 0
L	LBIT7	LBIT6	LBIT5	LBIT4	LBIT3	LBIT2	LBIT1	LBIT0
	R/W	R/W	R/W	R/W	R/W	R/W	R/W	R/W

⇒ **Example: Reading a data from RAM address 20H of bank 0, it can use indirectly addressing mode to access data as following.**

```
B0MOV H, #00H ; To set RAM bank 0 for H register
B0MOV L, #20H ; To set location 20H for L register
B0MOV A, @HL ; To read a data into ACC
```

⇒ **Example: Clear general-purpose data memory area of bank 0 using @HL register.**

```
CLR    H           ; H = 0, bank 0
MOV    A, #07FH
B0MOV  L, A        ; L = 7FH, the last address of the data memory area
CLR_HL_BUF:
CLR    @HL        ; Clear @HL to be zero
DECMS L           ; L - 1, if L = 0, finish the routine
JMP    CLR_HL_BUF ; Not zero

CLR    @HL
END_CLR:           ; End of clear general purpose data memory area of bank 0
:
:
```

Y, Z REGISTERS

The Y and Z registers are 8-bit buffers. There are three major functions of these registers. First, Y and Z registers can be working registers. Second, these two registers can be used as data pointers as @YZ register. Third, the registers can be address ROM location in order to look-up ROM data.

Y initial value = 0000 0000

084H	Bit 7	Bit 6	Bit 5	Bit 4	Bit 3	Bit 2	Bit 1	Bit 0
Y	YBIT7	YBIT6	YBIT5	YBIT4	YBIT3	YBIT2	YBIT1	YBIT0
	R/W	R/W	R/W	R/W	R/W	R/W	R/W	R/W

Z initial value = 0000 0000

083H	Bit 7	Bit 6	Bit 5	Bit 4	Bit 3	Bit 2	Bit 1	Bit 0
Z	ZBIT7	ZBIT6	ZBIT5	ZBIT4	ZBIT3	ZBIT2	ZBIT1	ZBIT0
	R/W	R/W	R/W	R/W	R/W	R/W	R/W	R/W

The @YZ is data point_1 index buffer located at address E7H in RAM bank 0. It employs Y and Z registers to addressing RAM location in order to read/write data through @YZ. The Lower 4-bit of Y register is pointed to RAM bank number and Z register is pointed to RAM address number, respectively. The higher 4-bit data of Y register is truncated in RAM indirectly access mode.

- **Example: Reading a data from RAM address 25H of bank 1, it can use indirectly addressing mode to access data as following.**

```
B0MOV Y, #01H ; To set RAM bank 1 for Y register
B0MOV Z, #25H ; To set location 25H for Z register
B0MOV A, @YZ ; To read a data into ACC
```

- **Example: Clear general-purpose data memory area of bank 1 using @YZ register.**

```
MOV   A, #1
B0MOV Y, A           ; Y = 1, bank 1
MOV   A, #07FH
B0MOV Z, A           ; Y = 7FH, the last address of the data memory area

CLR_YZ_BUF:
CLR   @YZ           ; Clear @YZ to be zero

DECMS Z             ; Y - 1, if Y= 0, finish the routine
JMP   CLR_YZ_BUF   ; Not zero

CLR   @YZ

END_CLR:            ; End of clear general purpose data memory area of bank 0
```

X REGISTERS

There are two major functions of the X register. First, X register can be used as working registers. Second, the X registers must be clear in order to look-up the ROM data. The SN8P1700's program counter only has 12-bit. In look-up table function, the users can omit X register.

X initial value = 0000 0000

085H	Bit 7	Bit 6	Bit 5	Bit 4	Bit 3	Bit 2	Bit 1	Bit 0
X	XBIT7	XBIT6	XBIT5	XBIT4	XBIT3	XBIT2	XBIT1	XBIT0
	R/W	R/W	R/W	R/W	R/W	R/W	R/W	R/W

➤ **Note: Please consult the "LOOK-UP TABLE DESCRIPTION" about X register look-up table application.**

R REGISTERS

The R register is an 8-bit buffer. There are two major functions of the register. First, R register can be working registers. Second, the R registers can be store high-byte data of look-up ROM data. After MOVC instruction executed, the high-byte data of a ROM address will stores in R register and the low-byte data in ACC.

R initial value = 0000 0000

082H	Bit 7	Bit 6	Bit 5	Bit 4	Bit 3	Bit 2	Bit 1	Bit 0
R	RBIT7	RBIT6	RBIT5	RBIT4	RBIT3	RBIT2	RBIT1	RBIT0
	R/W	R/W	R/W	R/W	R/W	R/W	R/W	R/W

PROGRAM FLAG

The PFLAG includes carry flag (C), decimal carry flag (DC) and zero flag (Z). If the result of operating is zero or there is carry, borrow occurrence, then these flags will set to PFLAG register.

PFLAG initial value = XXXX X000

086H	Bit 7	Bit 6	Bit 5	Bit 4	Bit 3	Bit 2	Bit 1	Bit 0
PFLAG	NT0	NPD	-	-	-	C	DC	Z
	R/W	R/W	-	-	-	R/W	R/W	R/W

RESET/WAKEUP FLAG

NT0	NPD	Description
0	0	Watchdog timer overflow in sleep mode. In sleep mode must set "INT_16K_RC" code option as "Always_On" to enable watchdog timer.
0	1	Watchdog timer overflow in normal/slow/green mode.
1	0	Stop system clock (High or Low clock). There are two cases as following: 1. In normal mode: Stop high clock or enter sleep mode (STPHX=1 or CPUM [1:0] = 01) 2. In slow mode: enter sleep mode (CPUM [1:0] = 01)
1	1	External reset or LVD active

- **Note: Watchdog timer is still running even "Watchdog" code option is disabled. User can disable watchdog code option then treat NT0/NPD as another timer flag.**

CARRY FLAG

C = 1: If executed arithmetic addition with occurring carry signal or executed arithmetic subtraction without borrowing signal or executed rotation instruction with shifting out logic "1".

C = 0: If executed arithmetic addition without occurring carry signal or executed arithmetic subtraction with borrowing signal or executed rotation instruction with shifting out logic "0".

DECIMAL CARRY FLAG

DC = 1: If executed arithmetic addition with occurring carry signal from low nibble or executed arithmetic subtraction without borrow signal from high nibble.

DC = 0: If executed arithmetic addition without occurring carry signal from low nibble or executed arithmetic subtraction with borrow signal from high nibble.

ZERO FLAG

Z = 1: After operation, the content of ACC is zero.

Z = 0: After operation, the content of ACC is not zero.

ACCUMULATOR

The ACC is an 8-bit data register responsible for transferring or manipulating data between ALU and data memory. If the result of operation is zero (Z) or carry (C or DC) occurs, then these flags will set to PFLAG register.

ACC is not in data memory (RAM), so ACC can't be access by "BOMOV" instruction during the instant addressing mode.

⇒ Example: Read and write ACC value.

; Read ACC data and store in BUF data memory

```
MOV      BUF, A
.
```

; Write a immediate data into ACC

```
MOV      A, #0FH
.
```

; Write ACC data from BUF data memory

```
MOV      A, BUF
.
```

PUSH and POP instructions don't store ACC value as any interrupt service executed. ACC must be stored in another data memory defined by users. Once interrupt occurs, these data must be stored in the data memory based on the user's program as follows.

* **Note: "PUSH", "POP" instructions only process 0x80~0x87 working registers and PFLAG register. Users have to save and load ACC by program as interrupt occurrence.**

⇒ Example: Protect ACC and working registers.

```
ACCBUF    EQU    00H    ; ACCBUF is ACC data buffer in bank 0.
```

```
INT_SERVICE:
```

```
    B0XCH A, ACCBUF ; Store ACC value
```

```
    PUSH. .          ; Push instruction
```

```
    .
```

```
    .
```

```
    POP          ; Pop instruction
```

```
    B0XCH A, ACCBUF ; Re-load ACC
```

```
    RETI          ; Exit interrupt service vector
```

➤ **Notice: To save and re-load ACC data must be used "B0XCH" instruction, or the PFLAG value maybe modified by ACC.**

STACK OPERATIONS

OVERVIEW

The stack buffer of SN8P1900 has 8-level high area and each level is 12-bit length. This buffer is designed to save and restore program counter (PC) data when interrupt service executes. The STKP register is designed to point active level to save or restore data from stack buffer for kernel circuit. The STK_NH and STK_NL are the 12-bit stack buffers to store program counter (PC) data.

STACK BUFFER

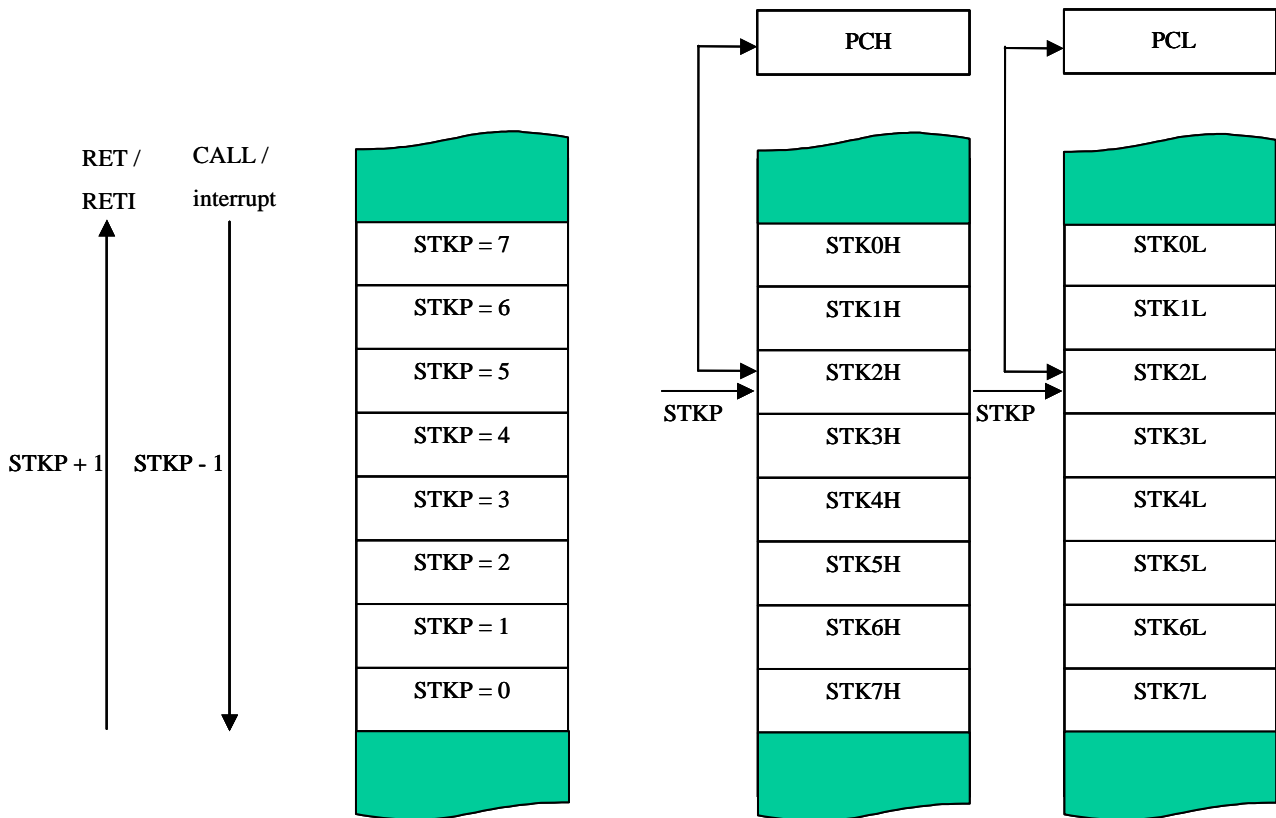

Figure 3-3 Stack-Save and Stack-Restore Operation

STACK REGISTERS

The stack pointer (STKP) is a 4-bit register to store the address used to access the stack buffer, 12-bits data memory (STK_NH and STK_NL) set aside for temporary storage of stack addresses.

The two stack operations write to the top of the stack (Stack-Save) and read (Stack-Restore) from the top of stack. Stack-Save operation decreases the STKP and the Stack-Restore operation increases one each time. That makes the STKP always points to the top address of stack buffer and writes the last program counter value (PC) into the stack buffer.

The program counter (PC) value is stored in the stack buffer before a CALL instruction executed or during interrupt service routine. Stack operation is a LIFO type (Last in and first out). The stack pointer (STKP) and stack buffer (STK_NH and STK_NL) are located in the bank 0.

STKP (stack pointer) initial value = 0xxx 1111

0DFH	Bit 7	Bit 6	Bit 5	Bit 4	Bit 3	Bit 2	Bit 1	Bit 0
STKP	GIE	-	-	-	STKPB3	STKPB2	STKPB1	STKPB0
	R/W	-	-	-	R/W	R/W	R/W	R/W

STKPB_N: Stack pointer. (n = 0 ~ 3)

GIE: Global interrupt control bit. 0 = disable, 1 = enable. More detail information is in interrupt chapter.

⇒ **Example: Stack pointer (STKP) reset routine.**

```
MOV      A, #00001111B
B0MOV   STKP, A
```

STK_N (stack buffer) initial value = XXXX XXXX XXXX XXXX, STK_N = STK_NH + STK_NL (n = 7 ~ 0)

0F0H~0FFH	Bit 7	Bit 6	Bit 5	Bit 4	Bit 3	Bit 2	Bit 1	Bit 0
STK_NH	-	-	-	SnPC12	SnPC11	SnPC10	SnPC9	SnPC8
	-	-	R/W	R/W	R/W	R/W	R/W	R/W

0F0H~0FFH	Bit 7	Bit 6	Bit 5	Bit 4	Bit 3	Bit 2	Bit 1	Bit 0
STK_NL	SnPC7	SnPC6	SnPC5	SnPC4	SnPC3	SnPC2	SnPC1	SnPC0
	R/W	R/W	R/W	R/W	R/W	R/W	R/W	R/W

STK_NH: Store PCH data as interrupt or call executing. The n expressed 0 ~7.

STK_NL: Store PCL data as interrupt or call executing. The n expressed 0 ~7.

STACK OPERATION EXAMPLE

The two kinds of Stack-Save operations to reference the stack pointer (STKP) and write the program counter contents (PC) into the stack buffer are CALL instruction and interrupt service. Under each condition, the STKP is decreased and points to the next available stack location. The stack buffer stores the program counter about the op-code address. The Stack-Save operation is as following table.

Stack Level	STKP Register				Stack Buffer		Description
	STKPB3	STKPB2	STKPB1	STKPB0	High Byte	Low Byte	
0	1	1	1	1	STK0H	STK0L	-
1	1	1	1	0	STK1H	STK1L	-
2	1	1	0	1	STK2H	STK2L	-
3	1	1	0	0	STK3H	STK3L	-
4	1	0	1	1	STK4H	STK4L	-
5	1	0	1	0	STK5H	STK5L	-
6	1	0	0	1	STK6H	STK6L	-
7	1	0	0	0	STK7H	STK7L	-
>8	-	-	-	-	-	-	Stack Overflow

Table 3-1. STKP, STK_NH and STK_NL relative of Stack-Save Operation

There is a Stack-Restore operation corresponding each push operation to restore the program counter (PC). The RETI instruction is for interrupt service routine. The RET instruction is for CALL instruction. When a Stack-Restore operation executes the STKP increases and points to the next free stack location. The stack buffer restores the last program counter (PC) to the program counter registers. The Stack-Restore operation is as following table.

Stack Level	STKP Register				Stack Buffer		Description
	STKPB3	STKPB2	STKPB1	STKPB0	High Byte	Low Byte	
7	1	0	0	0	STK7H	STK7L	-
6	1	0	0	1	STK6H	STK6L	-
5	1	0	1	0	STK5H	STK5L	-
4	1	0	1	1	STK4H	STK4L	-
3	1	1	0	0	STK3H	STK3L	-
2	1	1	0	1	STK2H	STK2L	-
1	1	1	1	0	STK1H	STK1L	-
0	1	1	1	1	STK0H	STK0L	-

Table 3-2. STKP, STK_NH and STK_NL relative of Stack-Restore Operation

PROGRAM COUNTER

The program counter (PC) is a 13-bit binary counter separated into the high-byte 5 bits and the low-byte 8 bits. This counter is responsible for pointing a location in order to fetch an instruction for kernel circuit. Normally, the program counter is automatically incremented with each instruction during program execution.

Besides, it can be replaced with specific address by executing CALL or JMP instruction. When JMP or CALL instruction is executed, the destination address will be inserted to bit 0 ~ bit 12.

PC Initial value = XXX0 0000 0000 0000

	Bit 15	Bit 14	Bit 13	Bit 12	Bit 11	Bit 10	Bit 9	Bit 8	Bit 7	Bit 6	Bit 5	Bit 4	Bit 3	Bit 2	Bit 1	Bit 0
PC	-	-	-	0	0	0	0	0	0	0	0	0	0	0	0	0
	PCH							PCL								

PCH Initial value = XXXX 0000

0CFH	Bit 7	Bit 6	Bit 5	Bit 4	Bit 3	Bit 2	Bit 1	Bit 0
PCH	-	-	-	PC12	PC11	PC10	PC9	PC8
	-	-	-	R/W	R/W	R/W	R/W	R/W

PCL Initial value = 0000 0000

0CEH	Bit 7	Bit 6	Bit 5	Bit 4	Bit 3	Bit 2	Bit 1	Bit 0
PCL	PC7	PC6	PC5	PC4	PC3	PC2	PC1	PC0
	R/W	R/W	R/W	R/W	R/W	R/W	R/W	R/W

ONE ADDRESS SKIPPING

There are 9 instructions (CMPRS, INCS, INCMS, DECS, DECMS, BTS0, BTS1, B0BTS0, B0BTS1) with one address skipping function. If the result of these instructions is matched, the PC will add 2 steps to skip next instruction.

If the condition of bit test instruction is matched, the PC will add 2 steps to skip next instruction.

```

B0BTS1 FC      ; Skip next instruction, if Carry flag = 1
JMP   C0STEP ; Else jump to C0STEP.
.
C0STEP: NOP
B0MOV A, BUF0 ; Move BUF0 value to ACC.
B0BTS0 FZ      ; Skip next instruction, if Zero flag = 0.
JMP   C1STEP ; Else jump to C1STEP.
.
C1STEP: NOP

```

If the ACC is equal to the immediate data or memory, then PC will add 2 steps to skip next instruction.

```

CMPRS A, #12H ; Skip next instruction, if ACC = 12H.
JMP   C0STEP ; Else jump to C0STEP.
.
C0STEP: NOP

```

If the result after increasing 1 or decreasing 1 is 0xffh (for DECS and DECMS) or 0x00h (for INCS and INCMS), the PC will add 2 steps to skip next instruction.

INCS instruction:

```

INCS BUF0      ; Skip next instruction, if BUF0 = 0X00H.
JMP   C0STEP ; Else jump to C0STEP.
.
C0STEP: NOP

```

INCMS instruction:

```

INCMS BUF0      ; Skip next instruction, if BUF0 = 0X00H.
JMP   C0STEP ; Else jump to C0STEP.
.
C0STEP: NOP

```

DECS instruction:

```

DECS BUF0      ; Skip next instruction, if BUF0 = 0XFFH.
JMP   C0STEP ; Else jump to C0STEP.
.
C0STEP: NOP

```

DECMS instruction:

```

DECMS BUF0      ; Skip next instruction, if BUF0 = 0XFFH.
JMP   C0STEP ; Else jump to C0STEP.
.
C0STEP: NOP

```

MULTI-ADDRESS JUMPING

User can jump round multi-address by either JMP instruction or "ADD PCL, A" instruction to activate multi-address jumping function. If carry signal occurs after execution of "ADD PCL, A", the carry signal will not affect PCH register.

⇒ **Example: If PC = 0323H (PCH = 03H, PCL = 23H)**

```

; PC = 0323H
      MOV   A, #28H
      B0MOV PCL, A ; Jump to address 0328H
      .
      .
; PC = 0328H
      MOV   A, #00H
      B0MOV PCL, A ; Jump to address 0300H

```

⇒ **Example: If PC = 0323H (PCH = 03H, PCL = 23H)**

```

; PC = 0323H
      B0ADD PCL, A ; PCL = PCL + ACC, the PCH cannot be changed.
      JMP  A0POINT ; If ACC = 0, jump to A0POINT
      JMP  A1POINT ; ACC = 1, jump to A1POINT
      JMP  A2POINT ; ACC = 2, jump to A2POINT
      JMP  A3POINT ; ACC = 3, jump to A3POINT

```

4 ADDRESSING MODE

OVERVIEW

The SN8P1900 provides three addressing modes to access RAM data, including immediate addressing mode, directly addressing mode and indirectly address mode. The main purpose of the three different modes is described in the following:

IMMEDIATE ADDRESSING MODE

The immediate addressing mode uses an immediate data to set up the location (MOV A, #I, B0MOV M, #I) in ACC or specific RAM.

Immediate addressing mode

```
MOV A, #12H ; To set an immediate data 12H into ACC
```

DIRECTLY ADDRESSING MODE

The directly addressing mode uses address number to access memory location (MOV A, 12H, MOV 12H,A).

Directly addressing mode

```
B0MOV A, 12H ; To get a content of location 12H of bank 0 and save in ACC
```

INDIRECTLY ADDRESSING MODE

The indirectly addressing mode is to set up an address in data pointer registers (Y/Z) and uses MOV instruction to read/write data between ACC and @YZ register (MOV A, @YZ, MOV @YZ, A).

➔ Example: Indirectly addressing mode with @YZ register

```
CLR    Y           ; To clear Y register to access RAM bank 0.
B0MOV Z, #12H     ; To set an immediate data 12H into Z register.
B0MOV A, @YZ      ; Use data pointer @YZ reads a data from RAM location
                  ; 012H into ACC.
```

```
MOV    A, #01H
B0MOV Y, A        ; To set Y = 1 for accessing RAM bank 1.
B0MOV Z, #12H     ; To set an immediate data 12H into Z register.
B0MOV A, @YZ      ; Use data pointer @YZ reads a data from RAM location
                  ; 012H into ACC.
```

```
MOV    A, #0FH
B0MOV Y, A        ; To set Y = 15 for accessing RAM bank 15.
B0MOV Z, #12H     ; To set an immediate data 12H into Z register.
B0MOV A, @YZ      ; Use data pointer @YZ reads a data from RAM location 012H
                  ; Into ACC.
```

TO ACCESS DATA in RAM BANK 0

In the RAM bank 0, this area memory can be read/written by these three access methods.

⇒ **Example 1: To use RAM bank0 dedicate instruction (Such as B0xxx instruction).**

B0MOV A, 12H ; To move content from location 12H of RAM bank 0 to ACC

⇒ **Example 2: To use direct addressing mode (through RBANK register).**

B0MOV RBANK, #00H ; To set RAM bank = 0
MOV A, 12H ; To move content from location 12H of RAM bank 0 to ACC

⇒ **Example 3: To use indirectly addressing mode with @YZ register.**

CLR Y ; To clear Y register for accessing RAM bank 0.
B0MOV Z, #12H ; To set an immediate data 12H into Z register.
B0MOV A, @YZ ; Use data pointer @YZ reads a data from RAM location
; 012H into ACC.

TO ACCESS DATA in RAM BANK 1

In the RAM bank 1, this area memory can be read/written by these two access methods.

⇒ **Example 1: To use directly addressing mode (Through RBANK register).**

B0MOV RBANK, #01H ; To set RAM bank = 1
MOV A, 12H ; To move content from location 12H of RAM bank 1 to ACC

⇒ **Example 2: To use indirectly addressing mode with @YZ register.**

MOV A, #01H
B0MOV Y, A ; To set Y = 1 for accessing RAM bank 1.
B0MOV Z, #12H ; To set an immediate data 12H into Z register.
B0MOV A, @YZ ; Use data pointer @YZ reads a data from RAM location
; 012H into ACC.

TO ACCESS DATA in RAM BANK 15 (LCD RAM)

In the RAM bank 15, this area memory can be read/written by these two access methods.

Example 1: To use directly addressing mode (Through RBANK register).

B0MOV RBANK, #0FH ; To set RAM bank = 15
MOV A, 12H ; To move content from location 12H of RAM bank 15 to ACC

Example 2: To use indirectly addressing mode with @YZ register.

MOV A, #0FH
B0MOV Y, A ; To set Y = 15 for accessing RAM bank 15.
B0MOV Z, #12H ; To set an immediate data 12H into Z register.
B0MOV A, @YZ ; Use data pointer @YZ reads a data from RAM location 012H into
ACC.

5 SYSTEM REGISTER

OVERVIEW

The RAM area located in 80H~FFH bank 0 is system register area. The main purpose of system registers is to control peripheral hardware of the chip. Using system registers can control I/O ports, SIO, ADC, PWM, LCD, timers and counters by programming. The Memory map provides an easy and quick reference source for writing application program. To access these system registers is controlled by the select memory bank (RBANK = 0) or the bank 0 read/write instruction (B0MOV, B0BSET, B0BCLR...).

SYSTEM REGISTER ARRANGEMENT (BANK 0)

BYTES of SYSTEM REGISTER

SN8P1900

	0	1	2	3	4	5	6	7	8	9	A	B	C	D	E	F
8	L	H	R	Z	Y	X	PFLAG	RBANK	OPTION	LCDM1	-	-	-	-	-	-
9	AMPM	AMPCHS	AMPCKS	ADCM	ADCKS	CPM	CCKS	DFM	ADCDL	ADCDH	-	-	-	-	-	-
A	-	-	-	-	-	-	-	-	-	-	-	-	-	-	-	-
B	-	-	-	-	SIOM	SIOR	SIOB	-	-	-	-	-	-	-	-	PEDGE
C	P1W	P1M	-	-	P5M	-	-	INTRQ	INTEN	OSCM	-	-	TC0R	PCL	PCH	-
D	P0	P1	P2	-	-	P5	-	-	T0M	T0C	TC0M	TC0C	TC1M	TC1C	TC1R	STKP
E	P0UR	P1UR	P2UR	-	-	P5UR	@HL	@YZ	-	-	-	-	-	-	-	-
F	STK7	STK7	STK6	STK6	STK5	STK5	STK4	STK4	STK3	STK3	STK2	STK2	STK1	STK1	STK0	STK0

Table 5-1. RAM register arrangement of SN8P1900

Description

L, H = Working & @HL addressing register	R = Working register and ROM look-up data buffer
Y, Z = Working, @YZ and ROM addressing register	OPTION= RTC and RCLK options.
PFLAG = ROM page and special flag register	RBANK= RAM bank select register
AMPM = PGIA mode register	AMPCHS = PGIA channel selection
AMPCKS = PGIA clock selection	ADCM = ADC's mode register
ADCKS = ADC clock selection	CPM = Charge pump mode
CCKS = Charge pump clock selection	DFM = Decimation filter mode
ADCDL = ADC low-byte data buffer	ADCDH = ADC high-byte data buffer
SIOM = SIO mode control register	SIOR = SIO clock reload buffer
SIOB = SIO data buffer	P1W = Port 1 wakeup register
P _N M = Port N input/output mode register	P _N UR = Port N pull-up register
P _N = Port N data buffer	INTRQ = Interrupt request register
INTEN = Interrupt enable register	OSCM = Oscillator mode register
LCDM1= LCD mode register	PCH, PCL = Program counter
T0M = Timer 0 mode register	TC0M = Timer/Counter 0 mode register
T0C = Timer 0 counting register	TC0C = Timer/Counter 0 counting register
TC1M = Timer/Counter 1 mode register	TC0R = Timer/Counter 0 auto-reload data buffer
TC1C = Timer/Counter 1 counting register	
STKP = Stack pointer buffer	STK0~STK7 = Stack 0 ~ stack 7 buffer
@HL = RAM HL indirect addressing index pointer	@YZ = RAM YZ indirect addressing index pointer

BITS of SYSTEM REGISTER

Address	Bit7	Bit6	Bit5	Bit4	Bit3	Bit2	Bit1	Bit0	R/W	Name
080H	LBIT7	LBIT6	LBIT5	LBIT4	LBIT3	LBIT2	LBIT1	LBIT0	R/W	L
081H	HBIT7	HBIT6	HBIT5	HBIT4	HBIT3	HBIT2	HBIT1	HBIT0	R/W	H
082H	RBIT7	RBIT6	RBIT5	RBIT4	RBIT3	RBIT2	RBIT1	RBIT0	R/W	R
083H	ZBIT7	ZBIT6	ZBIT5	ZBIT4	ZBIT3	ZBIT2	ZBIT1	ZBIT0	R/W	Z
084H	YBIT7	YBIT6	YBIT5	YBIT4	YBIT3	YBIT2	YBIT1	YBIT0	R/W	Y
085H	XBIT7	XBIT6	XBIT5	XBIT4	XBIT3	XBIT2	XBIT1	XBIT0	R/W	X
086H	NT0	NPD	-	-	-	C	DC	Z	R/W	PFLAG
087H	-	-	-	-	RBNKS3	RBNKS2	RBNKS1	RBNKS0	R/W	RBANK
088H	-	-	-	-	RTCM1	RTCM0	-	RCLK	R/W	OPTION
089H	-	-	LCDBNK	-	LCDENB	BIAS	-	P2SEG	R/W	LCDM1
090H	-	-	FD1	FD0	GS2	GS1	GS0	AMPENB	R/W	AMPM
091H	-	-	-	-	-	CHS2	CHS1	CHS0	R/W	AMPCHS
092H	AMPCKS7	AMPCKS6	AMPCKS5	AMPCKS4	AMPCKS3	AMPCKS2	AMPCKS1	AMPCKS0	W	AMPCKS
093H	-	-	-	-	-	RVS1	RVS0	ADCENB	R/W	ADCM
094H	ADCKS7	ADCKS6	ADCKS5	ADCKS4	ADCKS3	ADCKS2	ADCKS1	ADCKS0	W	ADCKS
095H	-	-	-	-	CPSTS	CPAUTO	CPON	CPRENB	R/W	CPM
096H	CPCKS7	CPCKS6	CPCKS5	CPCKS4	CPCKS3	CPCKS2	CPCKS1	CPCKS0	W	CPCKS
097H	-	-	-	-	WRS1	WRS0	STOD	DRDY	R/W	DFM
098H	ADCB7	ADCB6	ADCB5	ADCB4	ADCB3	ADCB2	ADCB1	ADCB0	R	ADCDL
099H	ADCB15	ADCB14	ADCB13	ADCB12	ADCB11	ADCB10	ADCB9	ADCB8	R	ADCDH
0B4H	SENB	START	SRATE1	SRATE0	SIG	SCKMD	SEDE	TXRX	R/W	SIOM
0B5H	SIOR7	SIOR6	SIOR5	SIOR4	SIOR3	SIOR2	SIOR1	SIOR0	W	SIOR
0B6H	SIOB7	SIOB6	SIOB5	SIOB4	SIOB3	SIOB2	SIOB1	SIOB0	R/W	SIOB
0BFH	PEDGEN	-	-	P00G1	P00G0	-	-	-	R/W	PEDGE
0C0H	-	-	-	P14W	P13W	P12W	P11W	P10W	W	P1W
0C1H	-	-	-	P14M	P13M	P12M	P11M	P10M	R/W	P1M
0C5H	-	-	-	P54M	P53M	P52M	P51M	P50M	R/W	P5M
0C8H	-	TC1IRQ	TC0IRQ	T0IRQ	SIORQ	-	P01IRQ	P00IRQ	R/W	INTRQ
0C9H	-	TC1IEN	TC0IEN	T0IEN	SIOEN	-	P01IEN	P00IEN	R/W	INTEN
0CAH	WTCKS	WDRST	WDARTE	CPUM1	CPUM0	CLKMD	STPHX	-	R/W	OSCM
0CDH	TC0R7	TC0R6	TC0R5	TC0R4	TC0R3	TC0R2	TC0R1	TC0R0	W	TC0R
0CEH	PC7	PC6	PC5	PC4	PC3	PC2	PC1	PC0	R/W	PCL
0CFH	-	-	-	PC12	PC11	PC10	PC9	PC8	R/W	PCH
0D0H	-	-	-	-	-	-	P01	P00	R	P0
0D1H	-	-	-	P14	P13	P12	P11	P10	R/W	P1
0D2H	P27	P26	P25	P24	P23	P22	P21	P20	R	P2
0D5H	-	-	-	P54	P53	P52	P51	P50	R/W	P5
0D8H	T0ENB	T0RATE2	T0RATE1	T0RATE0	TC1X8	TC0X8	TC0GN	T0TB	R/W	T0M
0D9H	T0C7	T0C6	T0C5	T0C4	T0C3	T0C2	T0C1	T0C0	R/W	T0C
0DAH	TC0ENB	TC0RATE2	TC0RATE1	TC0RATE0	TC0CKS	ALOAD0	TC0OUT	PWM0OUT	R/W	TC0M
0DBH	TC0C7	TC0C6	TC0C5	TC0C4	TC0C3	TC0C2	TC0C1	TC0C0	R/W	TC0C
0DCH	TC1ENB	TC1RATE2	TC1RATE1	TC1RATE0	TC1CKS	ALOAD1	TC1OUT	PWM1OUT	R/W	TC1M
0DDH	TC1C7	TC1C6	TC1C5	TC1C4	TC1C3	TC1C2	TC1C1	TC1C0	R/W	TC1C
0DEH	TC1R7	TC1R6	TC1R5	TC1R4	TC1R3	TC1R2	TC1R1	TC1R0	W	TC1R
0DFH	GIE	-	-	-	STKPB3	STKPB2	STKPB1	STKPB0	R/W	STKP
0E0H	-	-	-	-	-	-	P01R	P00R	W	P0UR
0E1H	-	-	-	P14R	P13R	P12R	P11R	P10R	W	P1UR
0E2H	P27R	P26R	P25R	P24R	P23R	P22R	P21R	P20R	W	P2UR
0E5H	-	-	-	P54R	P53R	P52R	P51R	P50R	W	P5UR
0E6H	@HL7	@HL6	@HL5	@HL4	@HL3	@HL2	@HL1	@HL0	R/W	@HL
0E7H	@YZ7	@YZ6	@YZ5	@YZ4	@YZ3	@YZ2	@YZ1	@YZ0	R/W	@YZ

(To be continued)

Address	Bit7	Bit6	Bit5	Bit4	Bit3	Bit2	Bit1	Bit0	R/W	Remarks
0F0H	S7PC7	S7PC6	S7PC5	S7PC4	S7PC3	S7PC2	S7PC1	S7PC0	R/W	STK7L
0F1H	-	-	-	S7PC12	S7PC11	S7PC10	S7PC9	S7PC8	R/W	STK7H
0F2H	S6PC7	S6PC6	S6PC5	S6PC4	S6PC3	S6PC2	S6PC1	S6PC0	R/W	STK6L
0F3H	-	-	-	S6PC12	S6PC11	S6PC10	S6PC9	S6PC8	R/W	STK6H
0F4H	S5PC7	S5PC6	S5PC5	S5PC4	S5PC3	S5PC2	S5PC1	S5PC0	R/W	STK5L
0F5H	-	-	-	S5PC12	S5PC11	S5PC10	S5PC9	S5PC8	R/W	STK5H
0F6H	S4PC7	S4PC6	S4PC5	S4PC4	S4PC3	S4PC2	S4PC1	S4PC0	R/W	STK4L
0F7H	-	-	-	S4PC12	S4PC11	S4PC10	S4PC9	S4PC8	R/W	STK4H
0F8H	S3PC7	S3PC6	S3PC5	S3PC4	S3PC3	S3PC2	S3PC1	S3PC0	R/W	STK3L
0F9H	-	-	-	S3PC12	S3PC11	S3PC10	S3PC9	S3PC8	R/W	STK3H
0FAH	S2PC7	S2PC6	S2PC5	S2PC4	S2PC3	S2PC2	S2PC1	S2PC0	R/W	STK2L
0FBH	-	-	-	S2PC12	S2PC11	S2PC10	S2PC9	S2PC8	R/W	STK2H
0FCH	S1PC7	S1PC6	S1PC5	S1PC4	S1PC3	S1PC2	S1PC1	S1PC0	R/W	STK1L
0FDH	-	-	-	S1PC12	S1PC11	S1PC10	S1PC9	S1PC8	R/W	STK1H
0FEH	S0PC7	S0PC6	S0PC5	S0PC4	S0PC3	S0PC2	S0PC1	S0PC0	R/W	STK0L
0FFH	-	-	-	S0PC12	S0PC11	S0PC10	S0PC9	S0PC8	R/W	STK0H

Table 5-2. Bit System Register Table
➤ Note:

- a). All of register names had been declared in SN8ASM assembler.
- b). One-bit name had been declared in SN8ASM assembler with "F" prefix code.
- c). It will get logic "H" data, when use instruction to check empty location.
- d). The low nibble of ADR register is read only.
- e). "b0bset", "b0bclr", "bset", "bclr" of instructions just only support "R/W" registers.
- f). For detail description please refer file of "System Register Quick Reference Table"

6 POWER ON RESET

OVERVIEW

SN8P1900 provides two system resets. One is external reset and the other is low voltage detector (LVD). The external reset is a simple RC circuit connecting to the reset pin. The low voltage detector (LVD) is built in internal circuit. When one of the reset devices occurs, the system will reset and the system registers become initial value. The timing diagram is as following.

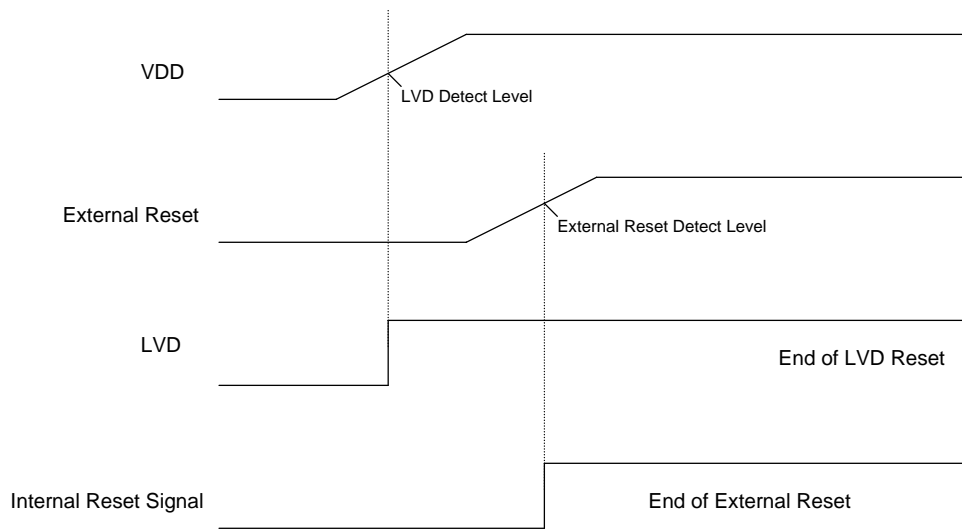

Figure 6-1 Power on Reset Timing Diagram

EXTERNAL RESET DESCRIPTION

The external reset is a low level active device. The reset pin receives the low voltage and resets the system. When the voltage detects high level, it stops resetting the system. Users can use an external reset circuit to control system operation. It is necessary that the VDD must be stable.

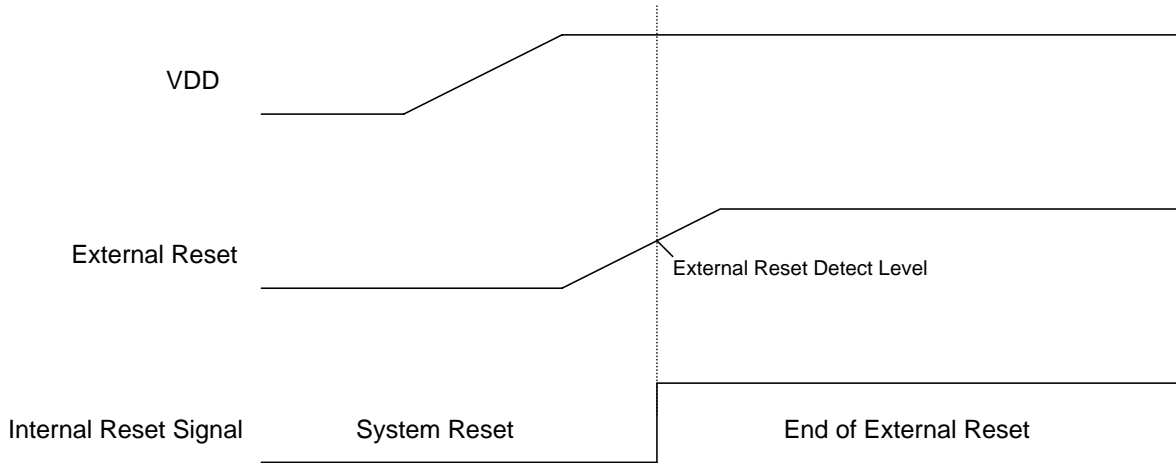

Figure 6-2 External Reset Timing Diagram

Users must be sure the VDD stable earlier than external reset (Figure 6-2) or the external reset will fail. The external reset circuit is a simple RC circuit as following.

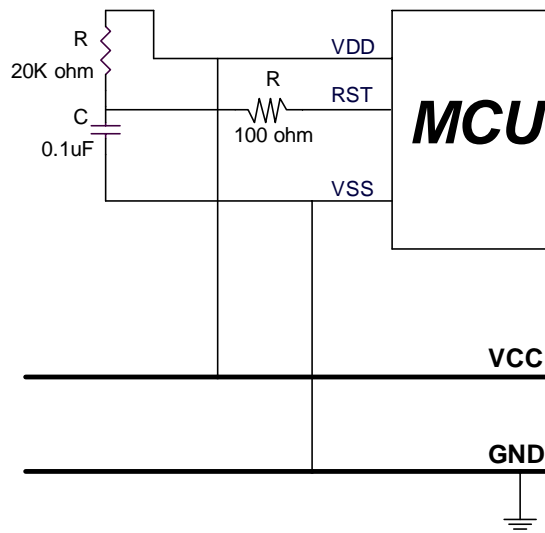

Figure 6-3. External Reset Circuit

In worse power condition as brown out reset. The reset pin may keep high level but the VDD is low voltage. That makes the system reset fail and chip error. To connect a diode from reset pin to VDD is a good solution. The circuit can force the capacitor to release electric charge and drop the voltage, and solve the error.

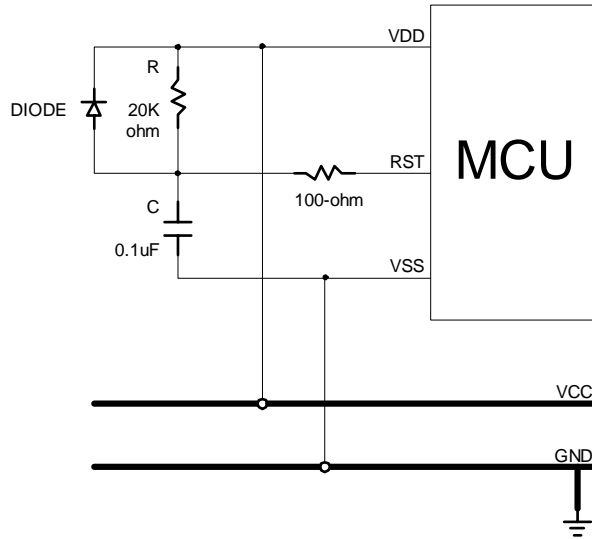

Figure 6-4. External Reset Circuit with Diode

LOW VOLTAGE DETECTOR (LVD) DESCRIPTION

The LVD is a low voltage detector. It detects VDD level and reset the system as the VDD lower than the desired voltage. The detect level is 1.8V. If the VDD lower than 1.8V, the system resets. The LVD function is controlled by code option. Users can turn on it for special application like worse power condition. LVD work with external reset function. They are OR active.

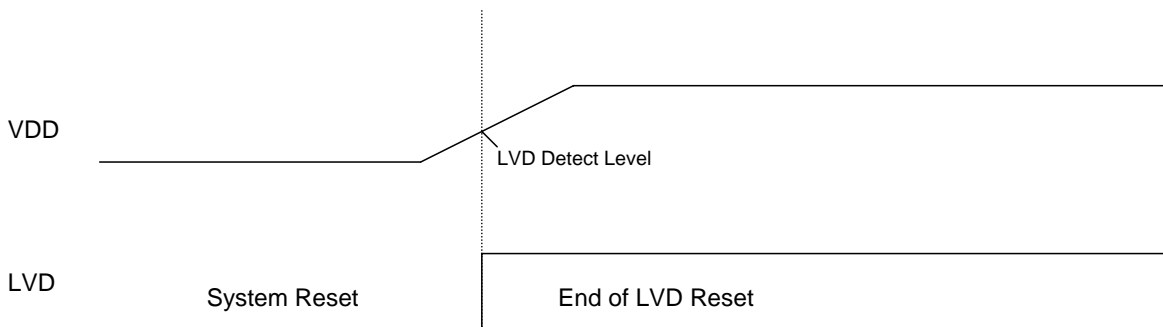

Figure 6-5. LVD Timing Diagram

➤ **Note: LVD is always Enable in SN8P1900 series**

7 OSCILLATORS

OVERVIEW

The SN8P1900 highly performs the dual clock micro-controller system. The dual clocks are high-speed clock and low-speed clock. The high-speed clock frequency is supplied through the external oscillator circuit. The low-speed clock frequency is supplied through external low clock oscillator (32.768K) by crystal or RC mode. Because **Real-Time-Clock (RTC) used low-speed clock for timer, 32768Hz X'tal usually used for low-speed clock to an exact Real-Time-Clock.**

The external high-speed clock and the external low-speed clock can be system clock (F_{OSC}). The system clock is divided by 4 to be the instruction cycle (F_{CPU}).

$$F_{CPU} = F_{OSC} / 4$$

The system clock is required by the following peripheral modules:

- ✓ **Basic timer (T0)**
- ✓ **Timer counter 0 (TC0)**
- ✓ **Timer counter 1 (TC1)**
- ✓ **Watchdog timer**
- ✓ **Serial I/O interface (SIO)**
- ✓ **AD converter**
- ✓ **PWM output (PWM0OUT, PWM1OUT)**
- ✓ **Buzzer output (TC0OUT, TC1OUT)**

CLOCK BLOCK DIAGRAM

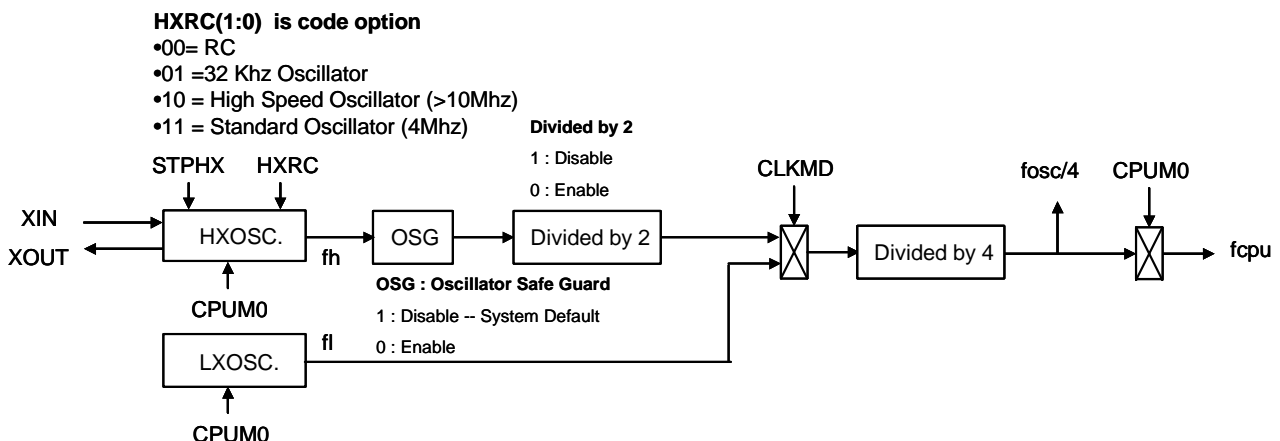

Figure 7-1. Clock Block Diagram

- HXOSC: External high-speed clock.
- LXOSC: External low-speed clock.
- OSG: Oscillator safe guard.

OSCM REGISTER DESCRIPTION

The OSCM register is an oscillator control register. It can control oscillator select, system mode, watchdog timer clock source and rate.

OSCM initial value = 0000 0000

0CAH	Bit 7	Bit 6	Bit 5	Bit 4	Bit 3	Bit 2	Bit 1	Bit 0
OSCM	WTCKS	WDRST	WDRATE	CPUM1	CPUM0	CLKMD	STPHX	-
	R/W	R/W	R/W	R/W	R/W	R/W	R/W	-

STPHX: Eternal high-speed oscillator control bit. 0 = free run, 1 = stop. This bit just only controls external high-speed oscillator. If STPHX=1, the external low-speed RC oscillator is still running.

CLKMD: System high/Low speed mode select bit. 0 = normal (dual) mode, 1 = slow mode.

CPUM1,CPUM0: CPU operating mode control bit. 00=normal, 01= sleep (power down) mode to turn off both high/low clock, 10=green mode, 11=reserved

WTCKS: Watchdog clock source select bit. 0 = F_{CPU}, 1 = internal RC low clock.

OPTION REGISTER DESCRIPTION

OPTION initial value = xxxx 00x0

088H	Bit 7	Bit 6	Bit 5	Bit 4	Bit 3	Bit 2	Bit 1	Bit 0
OPTION	-	-	-	-	RTCM1	RTCM0	-	RCLK
	-	-	-	-	R/W	R/W	-	R/W

RCLK: External low oscillator type control bit.

- 0 = Crystal Mode
- 1 = RC mode.

➤ **Note1:** Circuit diagram when RCLK=0 –External Low Clock sets as Crystal mode.

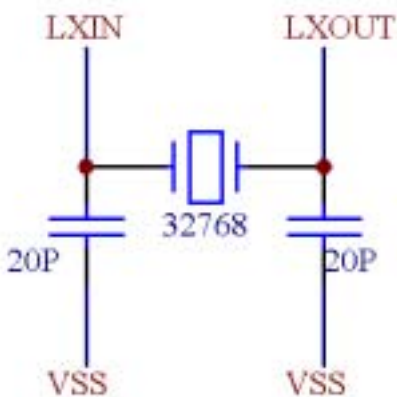

- **Note2: Circuit diagram when "RCLK=1" will enable external Low Clock sets as RC mode.**

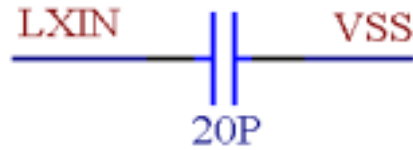

- * **Connect the C as near as possible to the VSS pin of micro-controller. The frequency of external low RC is decided by the capacitor value. Adjust capacitor value to about 32KHz frequency.**

RTCM [1:0] : Real time clock mode setting bits. There are 4 types RTC timing, 0.5/1/2/4 second.

RTCM1	RTCM0	RTC Time (Second)
0	0	0.5
0	1	1
1	0	2
1	1	4

- **Note1: Bit T0TB control T0 as normal timer or Real Time clock.**
 ➤ **Note2: S8KD-2 ICE can simulate 0.5 second RTC only. The others timers are valid by real chip.**

EXTERNAL HIGH-SPEED OSCILLATOR

SN8P1900 can be operated in four different oscillator modes. There are external RC oscillator modes, high crystal/resonator mode (12M code option), standard crystal/resonator mode (4M code option) and low crystal mode (32K code option). For different application, the users can select one of suitable oscillator mode by programming code option to generate system high-speed clock source after reset.

➔ Example: Stop external high-speed oscillator.

B0BSET FSTPHX ; To stop external high-speed oscillator only.

B0BSET FCPUM0 ; To stop external high-speed oscillator and external low-speed oscillator called power down mode (sleep mode).

OSCILLATOR MODE CODE OPTION

SN8P1900 has four oscillator modes for different applications. These modes are 4M, 12M, 32K and RC. The main purpose is to support different oscillator types and frequencies. High-speed crystal needs more current but the low one doesn't. For crystals, there are three steps to select. If the oscillator is RC type, to select "RC" and the system will divide the frequency by 2 automatically. User can select oscillator mode from Code Option table before compiling. The table is as follow.

Code Option	Oscillator Mode	Remark
00	RC mode	Output the F_{CPU} square wave from X_{OUT} pin.
01	32K	32768Hz
10	12M	12MHz ~ 16MHz
11	4M	3.58MHz

OSCILLATOR DEVIDE BY 2 CODE OPTION

SN8P1900 has an external clock divide by 2 function. It is a code option called "High_Clk / 2". If "High_Clk / 2" is enabled, the external clock frequency is divided by 8 for the F_{CPU} . F_{CPU} is equal to $F_{osc}/8$. If "High_Clk / 2" is disabled, the external clock frequency is divided by 4 for the F_{CPU} . The F_{CPU} is equal to $F_{osc}/4$.

➤ **Note: In RC mode, "High_Clk / 2" is always enabled.**

OSCILLATOR SAFE GUARD CODE OPTION

SN8P1900 builds in an oscillator safe guard (OSG) to make oscillator more stable. It is a low-pass filter circuit and stops high frequency noise into system from external oscillator circuit. This function makes system to work better under AC noisy conditions.

SYSTEM OSCILLATOR CIRCUITS

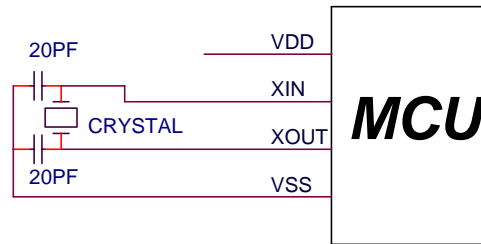

Figure 7-2. Crystal/Ceramic Oscillator

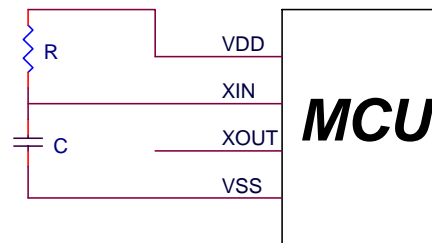

Figure 7-3. RC Oscillator

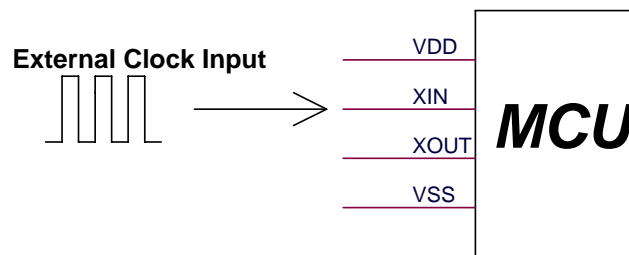

Figure 7-4. External clock input

- **Note1:** The VDD and VSS of external oscillator circuit must be from micro-controller. Don't connect them from power terminal.
- **Note2:** The external clock input mode can select RC type oscillator or crystal type oscillator of the code option and input the external clock into XIN pin.
- **Note3:** In RC type oscillator code option situation, the external clock's frequency is divided by 2.
- **Note4:** The power and ground of external oscillator circuit must be connected from the micro-controller's VDD and VSS. It is necessary to step up the performance of the whole system.

EXTERNAL RC OSCILLATOR FREQUENCY MEASUREMENT

There are two ways to get the F_{OSC} frequency of external RC oscillator. One measures the XOUT output waveform. Under external RC oscillator mode, the XOUT outputs the square waveform whose frequency is F_{CPU} . The other measures the external RC frequency by instruction cycle (F_{CPU}). The external RC frequency is the F_{CPU} multiplied by 4. We can get the F_{OSC} frequency of external RC from the F_{CPU} frequency. The sub-routine to get F_{CPU} frequency of external oscillator is as the following.

➔ Example: F_{CPU} instruction cycle of external oscillator

```
B0BSET    P1M.0           ; Set P1.0 to be output mode for outputting  $F_{CPU}$  toggle signal.
```

@@:

```
B0BSET    P1.0           ; Output  $F_{CPU}$  toggle signal in low-speed clock mode.
B0BCLR    P1.0           ; Measure the  $F_{CPU}$  frequency by oscilloscope.
JMP       @B
```

SYSTEM MODE DESCRIPTION

OVERVIEW

The chip is featured with low power consumption by switching around three different modes as following.

- High-speed mode
- Low-speed mode
- Power-down mode (Sleep mode)
- Green mode

In actual application, the user can adjust the chip's controller to work in these four modes by using OSCM register. At the high-speed mode, the instruction cycle (F_{CPU}) is $F_{osc}/4$. At the low-speed mode and 3V, the F_{CPU} is 16KHz/4.

NORMAL MODE

In normal mode, the system clock source is external high-speed clock. After power on, the system works under normal mode. The instruction cycle is $f_{osc}/4$. When the external high-speed oscillator is 3.58MHz, the instruction cycle is $3.58\text{MHz}/4 = 895\text{KHz}$. All software and hardware are executed and working. In normal mode, system can get into power down mode, slow mode and green mode.

SLOW MODE

In slow mode, the system clock source is external low-speed RC clock. To set $CLKMD = 1$, the system switches into slow mode. In slow mode, the system works as normal mode but the clock slower. The system in slow mode can get into normal mode, power down mode and green mode. To set $STPHX = 1$ to stop the external high-speed oscillator, and then the system consumes less power.

GREEN MODE

The green mode is a less power consumption mode. Under green mode, there are only T0/TC0 still counting and the other hardware stopping. The external high-speed oscillator or external low-speed oscillator is operating. To set $CPUM1 = 1$ and $CPUM0 = 0$, the system gets into green mode. The system can be waked up to last system mode by T0 timer timeout and P0, P1 trigger signal.

The green mode provides a time-variable wakeup function. Users can decide wakeup time by setting T0/TC0 timer. There are two channels into green mode. One is normal mode and the other is slow mode. In normal mode, the T0/TC0 timers overflow time is very short. In slow mode, the overflow time is longer. Users can select appropriate situation for their applications. Under green mode, the power consumption is 5u amp in 3V condition.

SLEEP (POWER DOWN) MODE

The power down mode is also called sleep mode. The chip stops working as sleeping status. The power consumption is very less almost to zero. The power down mode is usually applied to low power consuming system as battery power productions. To set $CUPM0 = 1$, the system gets into power down mode. The external high-speed and low-speed oscillators are turned off. The system can be waked up by P0, P1 trigger signal.

SYSTEM MODE CONTROL

SN8P1900 SYSTEM MODE BLOCK DIAGRAM

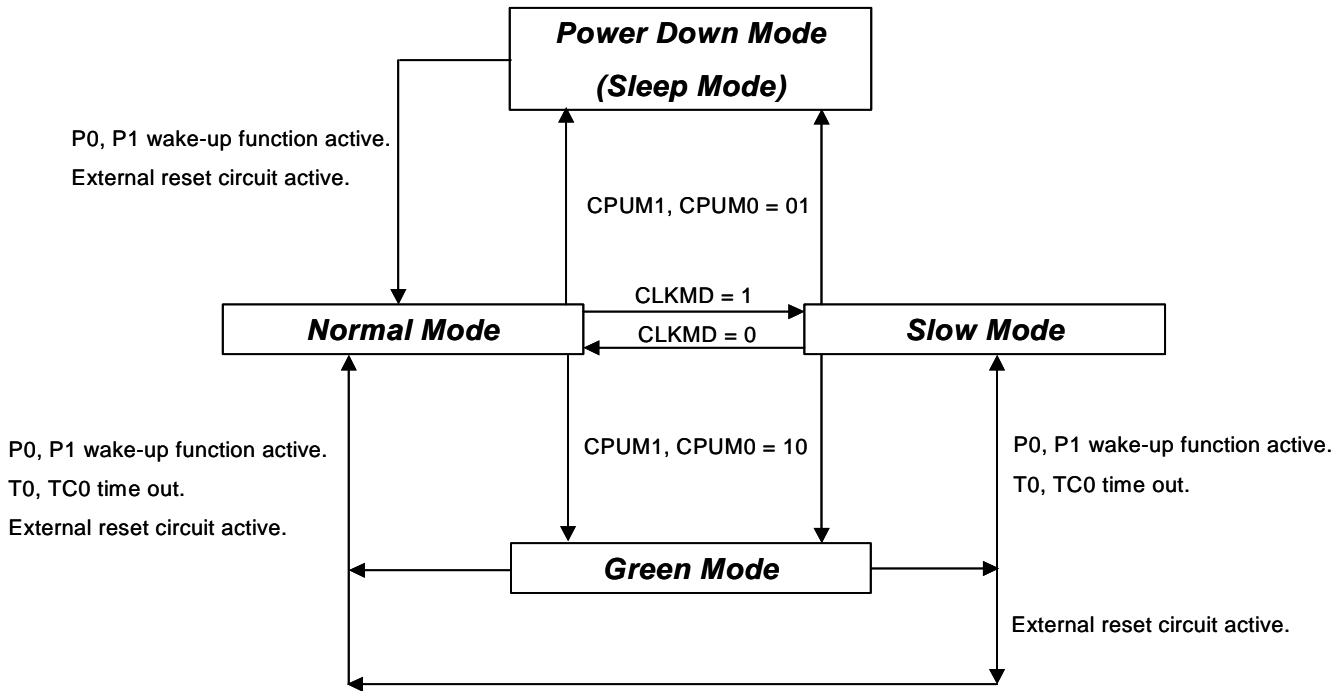

Figure 7-5. SN8P1900 System Mode Block Diagram

MODE	NORMAL	SLOW	Green	SLEEP	REMARK
HX osc.	Running	By STPHX	By STPHX	Stop	
LX osc.	Running	Running	Running	Stop	
CPU instruction	Executing	Executing	Stop	Stop	
T0 timer	*Active	*Active	*Active	Inactive	* Active by program
TC0 timer	*Active	*Active	*Active	Inactive	
TC1 timer	*Active	*Active	Inactive	Inactive	
Watchdog timer	Active	Active	Inactive	Inactive	
Internal interrupt	All active	All active	T0/TC0	All inactive	
External interrupt	All active	All active	All Active	All inactive	
Wakeup source	-	-	Port0, Port1, T0/TC0, Reset	P0, P1, Reset	

Table 7-1. Oscillator Operating Mode Description

- **Note:** In the green mode, T0 trigger signals can switch CPU return to the last mode. If the system was into green mode from normal mode, the system returns to normal mode. If the system was into green mode from slow mode, the system returns to slow mode.

SYSTEM MODE SWITCHING

Normal/Slow mode to power down (sleep) mode.
CPUM0 = 1)

```
B0BSET      FCPUM0      ; Set CPUM0 = 1.
```

➤ **Note: In normal mode and slow mode, the CPUM1 = 0 and can omit to set CPUM1 = 0 routine.**

Normal mode to slow mode.

```
B0BSET      FCLKMD      ;To set CLKMD = 1
B0BSET      FSTPHX      ;To stop external high-speed oscillator.
```

➤ **Note: To stop high-speed oscillator is not necessary and user can omit it.**

Switch slow mode to normal mode (The external high-speed oscillator is still running)

```
B0BCLR      FCLKMD      ;To set CLKMD = 0
```

Switch slow mode to normal mode (The external high-speed oscillator stops)

If external high clock stop and program want to switch back normal mode. It is necessary to delay at least 10mS for external clock stable.

```
B0BCLR      FSTPHX      ; Turn on the external high-speed oscillator.
@@:         B0MOV        Z, #27      ; If VDD = 5V, internal RC=32KHz (typical) will delay
            DECMS        Z           ; 0.125ms X 81 = 10.125ms for external clock stable
            JMP          @B
            ;
            B0BCLR      FCLKMD      ; Change the system back to the normal mode
```

Normal/Slow mode to green mode.

CPUM1, CPUM0 = 10

System can return to the last mode by P0, P1 and T0 wakeup function.

➤ **Example: Go into Green mode.**

```
B0BSET      FCPUM1      ; To set CPUM1, CPUM0 = 10
```

➤ **Note: In normal mode or slow mode, the CPUM0 = 0 and can omit to set CPUM0 = 0 routine.**

➤ **Example: Go into Green mode and enable T0 wakeup function.**

; Set T0 timer wakeup function.

```
B0BCLR      FT0IEN      ; To disable T0 interrupt service
B0BCLR      FT0ENB      ; To disable T0 timer
MOV         A,#20H      ;
B0MOV       T0M,A       ; To set T0 clock = FCPU / 64
MOV         A,#74H      ;
B0MOV       T0C,A       ; To set T0C initial value = 74H (To set T0 interval = 10 ms)
B0BCLR      FT0IEN      ; To disable T0 interrupt service
B0BCLR      FT0IRQ      ; To clear T0 interrupt request
B0BSET      FT0ENB      ; To enable T0 timer
```

; Go into green mode

```
B0BCLR      FCPUM0      ;To set CPUMx = 10
B0BSET      FCPUM1
```

➤ **Note: If T0ENB = 0, T0 is without wakeup from green mode to normal/slow mode function.**

WAKEUP TIME

OVERVIEW

The external high-speed oscillator needs a delay time from stopping to operating. The delay is very necessary and makes the oscillator to work stably. Some conditions during system operating, the external high-speed oscillator often runs and stops. Under these conditions, the delay time for external high-speed oscillator restart is called wakeup time.

There are two conditions need wakeup time. One is power down mode to normal mode. The other one is slow mode to normal mode. For the first case, SN8P1900 provides 2048 oscillator clocks to be the wakeup time. However, in the last case, users need to make the wakeup time by themselves.

HARDWARE WAKEUP

When the system is in power down mode (sleep mode), the external high-speed oscillator stops. When waked up from power down mode, MCU waits for 2048 external high-speed oscillator clocks as the wakeup time to stable the oscillator circuit. After the wakeup time, the system goes into the normal mode. The value of the wakeup time is as the following.

$$\text{The Wakeup time} = 1/F_{osc} * 2048 \text{ (sec)} + X'tal \text{ settling time}$$

The x'tal settling time is depended on the x'tal type. Typically, it is about 2~4mS.

⇒ **Example: In power down mode (sleep mode), the system is waked up by P0 or P1 trigger signal. After the wakeup time, the system goes into normal mode. The wakeup time of P0, P1 wakeup function is as the following.**

$$\text{The wakeup time} = 1/F_{osc} * 2048 = 0.57 \text{ ms} \quad (F_{osc} = 3.58\text{MHz})$$

$$\text{The total wakeup time} = 0.57\text{ms} + x'tal \text{ settling time}$$

Under power down mode (sleep mode), there are only I/O ports with wakeup function wake the system up to normal mode. The Port 0 and Port 1 have wakeup function. Port 0 wakeup function always enables, but the Port 1 is controlled by the P1W register.

P1W initial value = xx00 0000

0C0H	Bit 7	Bit 6	Bit 5	Bit 4	Bit 3	Bit 2	Bit 1	Bit 0
P1W	-	-	-	P14W	P13W	P12W	P11W	P10W
	-	-	-	W	W	W	W	W

P10W~P14W: Port 1 wakeup function control bits.

0 = None wakeup function

1 = Enable each pin of Port 1 wakeup function.

EXTERNAL WAKEUP TRIGGER CONTROL

In the SN8P1909/SN8P1908, the wakeup trigger direction is control by PEDGE register.

PEDGE initial value = 0xx0 0xxx

0BFH	Bit 7	Bit 6	Bit 5	Bit 4	Bit 3	Bit 2	Bit 1	Bit 0
PEDGE	PEDGEN	-	-	P00G1	P00G0	-	-	-
	R/W	-	-	R/W	R/W	-	-	-

Bit7 **PEDGEN**: Interrupt and wakeup trigger edge control bit.
 0 = Disable edge trigger function.
 Port 0: Low-level wakeup trigger and falling edge interrupt trigger.
 Port 1: Low-level wakeup trigger.
 1 = Enable edge trigger function.
 P0.0: Both Wakeup and interrupt trigger are controlled by P00G1 and P00G0 bits.
 P0.1: Both wakeup and interrupt trigger are Level change (falling or rising edge).
 Port 1: Wakeup trigger is Level change (falling or rising edge).

Bit[4:3] **P00G[1:0]**: Port 0.0 edge select bits.
 00 = reserved,
 01 = falling edge,
 10 = rising edge,
 11 = rising/falling bi-direction.

8 TIMERS COUNTERS

WATCHDOG TIMER (WDT)

The watchdog timer (WDT) is a binary up counter designed for monitoring program execution. If the program runs into the unknown status by noise interference, WDT overflow signal will reset this chip and restart operation. The instruction that clears the watchdog timer (B0BSET FWRDST) should be executed at proper points in a program within a given period. If an instruction that clears the watchdog timer is not executed within the period and the watchdog timer overflows, reset signal is generated and system is restarted with reset status. In order to generate different output timings, the user can control watchdog timer by modifying WDRATE control bit of OSCM register. The watchdog timer will be disabled at green and power down modes.

OSCM initial value = 0000 000x

0CAH	Bit 7	Bit 6	Bit 5	Bit 4	Bit 3	Bit 2	Bit 1	Bit 0
OSCM	WTCKS	WDRST	WDRATE	CPUM1	CPUM0	CLKMD	STPHX	-
	R/W	R/W	R/W	R/W	R/W	R/W	R/W	-

- Bit1 **STPHX:** External high-speed oscillator control bit.
0 = free run,
1 = stop.
Note: This bit only controls external high-speed oscillator. If STPHX=1, the internal low-speed RC oscillator is still running.

- Bit2 **CLKMD:** System high/Low speed mode select bit.
0 = normal (dual) mode,
1 = slow mode.

- Bit [4:3] **CPUM [1:0]:** CPU operating mode control bit.
00 = normal,
01 = sleep (power down) mode,
10 = green mode,
11 = reserved.

- Bit5 **WDRATE:** Watchdog timer rate select bit.
 $0 = F_{CPU} \div 2^{14}$
 $1 = F_{CPU} \div 2^8$

- Bit6 **WDRST:** Watchdog timer reset bit.
0 = No reset
1 = clear the watchdog timer's counter.
(The detail information is in watchdog timer chapter.)

- Bit7 **WTCKS:** Watchdog clock source select bit.
0 = F_{CPU}
1 = internal RC low clock.

WTCKS	WTRATE	CLKMD	Watchdog Timer Overflow Time
0	0	0	$1 / (F_{CPU} \div 2^{14} \div 16) = 293 \text{ ms}, F_{OSC}=3.58\text{MHz}$
0	1	0	$1 / (F_{CPU} \div 2^8 \div 16) = 500 \text{ ms}, F_{OSC} = 32768\text{Hz}$
0	0	1	$1 / (F_{CPU} \div 2^{14} \div 16) = 32\text{s}, F_{OSC} = 32768\text{Hz}$
0	1	1	$1 / (F_{CPU} \div 2^8 \div 16) = 500 \text{ ms}, F_{OSC} = 32768\text{Hz}$
1	-	-	$1 / (32768 \div 512 \div 16) \sim 0.25\text{s}$

Table 8-1. Watchdog timer overflow time table

➤ **Note:** *The watchdog timer can be enabled or disabled by the code option.*

➡ **Example:** An operation of watchdog timer is as following. To clear the watchdog timer's counter in the top of the main routine of the program.

Main:

```
BOBSET      FWDRST      ; Clear the watchdog timer's counter.  
.           .  
CALL        SUB1  
CALL        SUB2  
.           .  
.           .  
JMP         MAIN
```

BASIC TIMER 0 (T0)

OVERVIEW

The basic timer (T0) is an 8-bit binary up counter. It uses TOM register to select T0C's input clock for counting a precision time. If the T0 timer has occur an overflow (from FFH to 00H), it will continue counting and issue a time-out signal to trigger T0 interrupt to request interrupt service. The main purposes of the T0 basic timer is as following.

- **8-bit programmable timer:** Generates interrupts at specific time intervals based on the selected clock frequency.

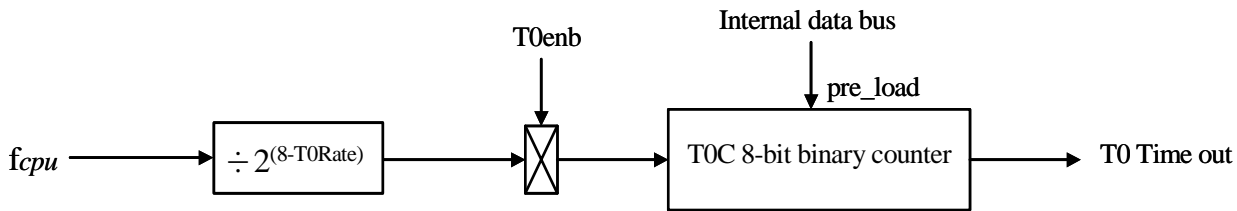

Figure 8-2. Basic Timer T0 Block Diagram

T0M REGISTER DESCRIPTION

The T0M is the basic timer mode register which is a 8-bit read/write register and only used the high nibble. By loading different value into the T0M register, users can modify the basic timer clock dynamically as program executing.

Eight rates for T0 timer can be selected by T0RATE0 ~ T0RATE2 bits. The range is from fcpu/2 to fcpu/256. The T0M initial value is zero and the rate is fcpu/256. The bit7 of T0M called T0ENB is the control bit to start T0 timer. The combination of these bits is to determine the T0 timer clock frequency and the intervals.

T0M initial value = 0000 xxxx

0D8H	Bit 7	Bit 6	Bit 5	Bit 4	Bit 3	Bit 2	Bit 1	Bit 0
T0M	T0ENB	T0RATE2	T0RATE1	T0RATE0	TC1X8	TC0X8	TC0GN	T0TB
	R/W	R/W	R/W	R/W	R/W	R/W	R/W	R/W

Bit7 **T0ENB:** T0 timer control bit.
 0 = Disable
 1 = Enable.

Bit[6:4] **T0RATE2~T0RATE0:** The T0 timer's clock source selects bits.

T0RATE [2:0]	TC0 Clock Source
000	F _{CPU} /256
001	F _{CPU} /128
...	...
110	F _{CPU} /4
111	F _{CPU} /2

Bit3 **TC1X8:** Multiple TC1 timer speed eight times. Refer TC1M register for detailed information.
 0 = TC1 clock came from Fcpu
 1 = TC1 clock came from Fosc

Bit2 **TC0X8:** Multiple TC0 timer speed eight times. Refer TC0M register for detailed information.
 0 = TC0 clock came from Fcpu
 1 = TC0 clock came from Fosc

- Bit1 **TC0GN:** Enable TC0 green mode wakeup function
 0 = Disable
 1 = Enable
- Bit0 **T0TB:** Timer 0 as the Real-Time clock time base.
 0 = Timer 0 function as a normal timer system.
 1 = Timer 0 function as a Real-Time Clock. The clock source of timer 0 will be switched to external low clock (32.768K crystal oscillator).

T0C COUNTING REGISTER

T0C is an 8-bit counter register for the basic timer (T0). T0C must be reset whenever the T0ENB is set “1” to start the basic timer. T0C is incremented by one with every clock pulse which frequency is determined by T0RATE0 ~ T0RATE2. When T0C has incremented to “0FFH”, it will be cleared to “00H” in next clock and an overflow generated. Under T0 interrupt service request (T0IEN) enable condition, the T0 interrupt request flag will be set “1” and the system executes the interrupt service routine. The T0C has no auto reload function. After T0C overflow, the T0C is continuing counting. Users need to reset T0C value to get a accurate time.

T0C initial value = xxxx xxxx

0D9H	Bit 7	Bit 6	Bit 5	Bit 4	Bit 3	Bit 2	Bit 1	Bit 0
T0C	T0C7	T0C6	T0C5	T0C4	T0C3	T0C2	T0C1	T0C0
	R/W	R/W	R/W	R/W	R/W	R/W	R/W	R/W

T0RATE	T0CLOCK	High speed mode (fcpu = 3.58MHz / 4)		Low speed mode (fcpu = 32768Hz / 4)	
		Max overflow interval	One step = max/256	Max overflow interval	One step = max/256
000	fcpu/256	73.2 ms	286us	8000 ms	31.25 ms
001	fcpu/128	36.6 ms	143us	4000 ms	15.63 ms
010	fcpu/64	18.3 ms	71.5us	2000 ms	7.8 ms
011	fcpu/32	9.15 ms	35.8us	1000 ms	3.9 ms
100	fcpu/16	4.57 ms	17.9us	500 ms	1.95 ms
101	fcpu/8	2.28 ms	8.94us	250 ms	0.98 ms
110	fcpu/4	1.14 ms	4.47us	125 ms	0.49 ms
111	fcpu/2	0.57 ms	2.23us	62.5 ms	0.24 ms

Figure 8-3. The Timing Table of Basic Timer T0.

The equation of T0C initial value is as following.

$$\boxed{T0C\ initial\ value = 256 - (T0\ interrupt\ interval\ time * input\ clock)}$$

- ⇒ **Example : To set 10ms interval time for T0 interrupt at 3.58MHz high-speed mode. T0C value (74H) = 256 - (10ms * fcpu/64)**

$$\begin{aligned}
 T0C\ initial\ value &= 256 - (T0\ interrupt\ interval\ time * input\ clock) \\
 &= 256 - (10ms * 3.58 * 10^6 / 4 / 64) \\
 &= 256 - (10^{-2} * 3.58 * 10^6 / 4 / 64) \\
 &= 116 \\
 &= 74H
 \end{aligned}$$

T0 BASIC TIMER OPERATION SEQUENCE

The T0 basic timer's sequence of operation can be following.

- Set the T0C initial value to setup the interval time.
- Set the T0ENB to be "1" to enable T0 basic timer.
- T0C is incremented by one with each clock pulse which frequency is corresponding to T0M selection.
- T0C overflow when T0C from FFH to 00H.
- When T0C overflow occur, the T0IRQ flag is set to be "1" by hardware.
- Execute the interrupt service routine.
- Users reset the T0C value and resume the T0 timer operation.

➤ Example: Setup the T0M and T0C.

```

B0BCLR      FT0IEN      ; To disable T0 interrupt service
B0BCLR      FT0ENB      ; To disable T0 timer
MOV         A,#20H      ;
B0MOV       T0M,A       ; To set T0 clock = fcpu / 64
MOV         A,#74H      ;
B0MOV       T0C,A       ; To set T0C initial value = 74H (To set T0 interval = 10 ms)
B0BSET      FT0IEN      ; To enable T0 interrupt service
B0BCLR      FT0IRQ      ; To clear T0 interrupt request
B0BSET      FT0ENB      ; To enable T0 timer
    
```

➤ Example: T0 interrupt service routine.

```

INT_SERVICE:
    ORG      8          ; Interrupt vector
    JMP      INT_SERVICE

    B0XCH    A, ACCBUF  ; Store ACC value.
    B0MOV    A, PFLAG
    B0MOV    PFLAGBUF, A ; Save PFLAG register in a buffer

    B0BTS1  FT0IRQ     ; Check T0IRQ
    JMP      EXIT_INT  ; T0IRQ = 0, exit interrupt vector

    B0BCLR  FT0IRQ     ; Reset T0IRQ
    MOV     A,#74H     ; Reload T0C
    B0MOV   T0C,A

    .       .          ; T0 interrupt service routine
    .       .
    JMP     EXIT_INT  ; End of T0 interrupt service routine and exit interrupt vector
    .       .
    .       .

EXIT_INT:
    B0MOV   A, PFLAGBUF ; Restore PFLAG register from buffer
    B0MOV   PFLAG, A
    B0XCH  A, ACCBUF   ; Restore ACC value.
    RETI   ; Exit interrupt vector
    
```

TIMER COUNTER 0 (TC0)

OVERVIEW

The timer counter 0 (TC0) is used to generate an interrupt request when a specified time interval has elapsed. TC0 has an auto re-loadable counter that consists of two parts: an 8-bit reload register (TC0R) into which you write the counter reference value, and an 8-bit counter register (TC0C) whose value is automatically incremented by counter logic.

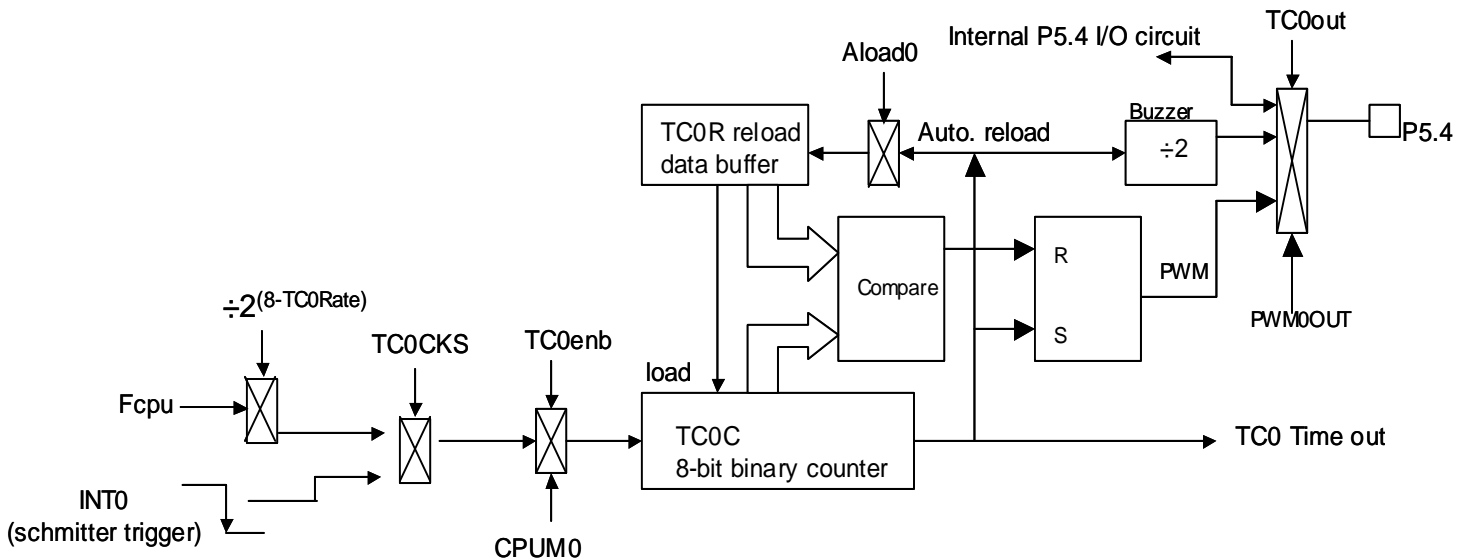

Figure 8-1. Timer Count TC0 Block Diagram

The main purposes of the TC0 timer counter is as following.

- **8-bit programmable timer:** Generates interrupts at specific time intervals based on the selected clock frequency.
- **Arbitrary frequency output (Buzzer output):** Outputs selectable clock frequencies to the BZ0 pin (P5.4).
- **PWM function:** PWM output can be generated by the PWM1OUT bit and output to PWM0OUT pin (P5.4).

TC0M MODE REGISTER

The TC0M is the timer counter mode register, which is an 8-bit read/write register. By loading different value into the TC0M register, users can modify the timer counter clock frequency dynamically when program executing.

Eight rates for TC0 timer can be selected by TC0RATE0 ~ TC0RATE2 and TC0X8 bit of T0M register. If TC0X8=1 the TC0 will faster 8 times than TC0X8 = 0(initial value). The 7th bit of TC0M named TC0ENB is the control bit to start TC0 timer.

TC0M initial value = 0000 0000

0DAH	Bit 7	Bit 6	Bit 5	Bit 4	Bit 3	Bit 2	Bit 1	Bit 0
TC0M	TC0ENB	TC0RATE2	TC0RATE1	TC0RATE0	TC0CKS	ALOAD0	TC0OUT	PWM0OUT
	R/W	R/W	R/W	R/W	R/W	R/W	R/W	R/W

Bit7 **TC0ENB**:TC0 counter/BZ0/PWM0OUT enable bit.
0 = disable,
1 = enable.

Bit[6:4] **TC0RATE[2:0]**:TC0 clock source selection bits. TC0X8 is 2nd bit of T0M register

TC0RATE [2:0]	TC0 Clock Source	
	TC0X8 = 0	TC0X8 = 1
000	$F_{CPU}/256 = F_{osc}/1024$	$F_{osc}/128$
001	$F_{CPU}/128 = F_{osc}/512$	$F_{osc}/64$
...
110	$F_{CPU}/4 = F_{osc}/16$	$F_{osc}/2$
111	$F_{CPU}/2 = F_{osc}/8$	F_{osc}

Note: $F_{CPU} = F_{osc} / 4$

Bit3 **TC0CKS**: TC0 clock source select bit.
0 = F_{CPU} ,
1 = External clock comes from INT0/P0.0 pin.

Bit2 **ALOAD0**: TC0 auto-reload function control bit.
0 = none auto-reload,
1 = auto-reload.

Bit1 **TC0OUT**: TC0 time-out toggle signal output control bit.
0 = To disable TC0 signal output and to enable P5.4's I/O function,
1 = To enable TC0's signal output and to disable P5.4's I/O function. (Auto-disable the PWM0OUT function.)

Bit0 **PWM0OUT**: TC0's PWM output control bit.
0 = To disable the PWM output,
1 = To enable the PWM output (The TC0OUT control bit must = 0)

➤ **Note:** When TC0CKS=1, TC0 became an external event counter. No more P0.0 interrupt request will be raised. (P00IRQ will be always 0)

TC0C COUNTING REGISTER

TC0C is an 8-bit counter register for the timer counter (TC0). TC0C must be reset whenever the TC0ENB is set "1" to start the timer counter. TC0C is incremented by one with a clock pulse which the frequency is determined by TC0RATE0 ~ TC0RATE2. When TC0C has incremented to "0FFH", it will be cleared to "00H" in next clock and an overflow is generated. Under TC0 interrupt service request (TC0IEN) enable condition, the TC0 interrupt request flag will be set "1" and the system executes the interrupt service routine.

TC0C initial value = xxxx xxxx

0DBH	Bit 7	Bit 6	Bit 5	Bit 4	Bit 3	Bit 2	Bit 1	Bit 0
TC0C	TC0C7	TC0C6	TC0C5	TC0C4	TC0C3	TC0C2	TC0C1	TC0C0
	R/W	R/W	R/W	R/W	R/W	R/W	R/W	R/W

TC0 OVERFLOW TIME

TC0 rate is determinate by TC0Rate and Code Option TC0_Counter, TC0Rate can set TC0 clock frequency and TC0_Counter set TC0 became 8-bit, 6-bit, 5-bit or 4-bit counter.

The equation of TC0C initial value is as following.

$$TC0C \text{ initial value} = N - (TC0 \text{ interrupt interval time} * \text{input clock})$$

Which N is determinate by code option: TC0_Counter

TC0_Counter	N	Max. TC0C value
8-bit	256	255
6-bit	64	63
5-bit	32	31
4-bit	16	15

➤ **Note:** The TC0C must small or equal than Max. TC0 value.

⇒ **Example:** To set 10ms interval time for TC0 interrupt at F_{OSC} = 3.58MHz.

$$TC0C \text{ value (74H)} = 256 - (10\text{ms} * F_{CPU}/64) \quad (TC0RATE=010, TC0_Counter=8\text{-bit}, TC0X8=0)$$

$$\begin{aligned} TC0C \text{ initial value} &= 256 - (TC0 \text{ interrupt interval time} * \text{input clock}) \\ &= 256 - (10\text{ms} * 3.58 * 10^6 / 4 / 64) \\ &= 256 - (10^{-2} * 3.58 * 10^6 / 4 / 64) \\ &= 116 \\ &= 74H \end{aligned}$$

⇒ **Example:** To set 1.25ms interval time for TC0 interrupt at F_{OSC} = 3.58MHz.

$$TC0C \text{ value (74H)} = 256 - (10\text{ms} * F_{CPU} / 64) \quad (TC0RATE=010, TC0_Counter=8\text{-bit}, TC0X8=1)$$

$$\begin{aligned} TC0C \text{ initial value} &= 256 - (TC0 \text{ interrupt interval time} * \text{input clock}) \\ &= 256 - (1.25\text{ms} * 3.58 * 10^6 / 32) \\ &= 256 - (0.00125 * 3.58 * 10^6 / 32) \\ &= 116 \\ &= 74H \end{aligned}$$

⇒ **Example:** To set 1ms interval time for TC0 interrupt at F_{OSC} = 3.58MHz.

$$TC0C \text{ value (32H)} = 64 - (1\text{ms} * F_{CPU} / 64) \quad (TC0RATE=010, TC0_Counter=6\text{-bit}, TC0X8=0)$$

$$\begin{aligned} TC0C \text{ initial value} &= 64 - (TC0 \text{ interrupt interval time} * \text{input clock}) \\ &= 64 - (1\text{ms} * 3.58 * 10^6 / 4 / 64) \\ &= 64 - (1^{-2} * 3.58 * 10^6 / 4 / 64) \\ &= 64-14 \\ &= 32H \end{aligned}$$

TC0_Counter=8-bit, TC0X8=0

TC0RATE	TC0CLOCK	High speed mode ($F_{CPU} = 3.58\text{MHz} / 4$)		Low speed mode ($F_{CPU} = 32768\text{Hz} / 4$)	
		Max overflow interval	One step = max/256	Max overflow interval	One step = max/256
000	$F_{CPU} / 256$	73.2 ms	286us	8000 ms	31.25 ms
001	$F_{CPU} / 128$	36.6 ms	143us	4000 ms	15.63 ms
010	$F_{CPU} / 64$	18.3 ms	71.5us	2000 ms	7.8 ms
011	$F_{CPU} / 32$	9.15 ms	35.8us	1000 ms	3.9 ms
100	$F_{CPU} / 16$	4.57 ms	17.9us	500 ms	1.95 ms
101	$F_{CPU} / 8$	2.28 ms	8.94us	250 ms	0.98 ms
110	$F_{CPU} / 4$	1.14 ms	4.47us	125 ms	0.49 ms
111	$F_{CPU} / 2$	0.57 ms	2.23us	62.5 ms	0.24 ms

TC0_Counter=6-bit , TC0X8=0

TC0RATE	TC0CLOCK	High speed mode ($F_{CPU} = 3.58\text{MHz} / 4$)		Low speed mode ($F_{CPU} = 32768\text{Hz} / 4$)	
		Max overflow interval	One step = max/64	Max overflow interval	One step = max/64
000	$F_{CPU} / 256$	18.3 ms	286us	2000 ms	31.25 ms
001	$F_{CPU} / 128$	9.15 ms	143us	1000 ms	15.63 ms
010	$F_{CPU} / 64$	4.57 ms	71.5us	500 ms	7.8 ms
011	$F_{CPU} / 32$	2.28 ms	35.8us	250 ms	3.9 ms
100	$F_{CPU} / 16$	1.14 ms	17.9us	125 ms	1.95 ms
101	$F_{CPU} / 8$	0.57 ms	8.94us	62.5 ms	0.98 ms
110	$F_{CPU} / 4$	0.285 ms	4.47us	31.25 ms	0.49 ms
111	$F_{CPU} / 2$	0.143 ms	2.23us	15.63 ms	0.24 ms

TC0_Counter=5-bit, TC0X8=0

TC0RATE	TC0CLOCK	High speed mode ($F_{CPU} = 3.58\text{MHz} / 4$)		Low speed mode ($F_{CPU} = 32768\text{Hz} / 4$)	
		Max overflow interval	One step = max/32	Max overflow interval	One step = max/32
000	$F_{CPU} / 256$	9.15 ms	286us	1000 ms	31.25 ms
001	$F_{CPU} / 128$	4.57 ms	143us	500 ms	15.63 ms
010	$F_{CPU} / 64$	2.28 ms	71.5us	250 ms	7.8 ms
011	$F_{CPU} / 32$	1.14 ms	35.8us	125 ms	3.9 ms
100	$F_{CPU} / 16$	0.57 ms	17.9us	62.5 ms	1.95 ms
101	$F_{CPU} / 8$	0.285 ms	8.94us	31.25 ms	0.98 ms
110	$F_{CPU} / 4$	0.143 ms	4.47us	15.63 ms	0.49 ms
111	$F_{CPU} / 2$	71.25 us	2.23us	7.81 ms	0.24 ms

TC0_Counter=4-bit, TC0X8=0

TC0RATE	TC0CLOCK	High speed mode ($F_{CPU} = 3.58\text{MHz} / 4$)		Low speed mode ($F_{CPU} = 32768\text{Hz} / 4$)	
		Max overflow interval	One step = max/16	Max overflow interval	One step = max/16
000	$F_{CPU} / 256$	4.57 ms	286us	500 ms	31.25 ms
001	$F_{CPU} / 128$	2.28 ms	143us	250 ms	15.63 ms
010	$F_{CPU} / 64$	1.14 ms	71.5us	125 ms	7.8 ms
011	$F_{CPU} / 32$	0.57 ms	35.8us	62.5 ms	3.9 ms
100	$F_{CPU} / 16$	0.285 ms	17.9us	31.25 ms	1.95 ms
101	$F_{CPU} / 8$	0.143 ms	8.94us	15.63 ms	0.98 ms
110	$F_{CPU} / 4$	71.25 us	4.47us	7.81 ms	0.49 ms
111	$F_{CPU} / 2$	35.63 us	2.23us	3.91 ms	0.24 ms

TC0_Counter=8-bit, TC0X8=1

TC0RATE	TC0CLOCK	High speed mode (F _{OSC} = 3.58MHz)		Low speed mode (F _{OSC} = 32768Hz)	
		Max overflow interval	One step = max/256	Max overflow interval	One step = max/256
000	F _{OSC} /128	9.153 ms	35.754us	1000 ms	3.91 ms
001	F _{OSC} /64	4.58 ms	17.877us	500 ms	1.95 ms
010	F _{OSC} /32	2.29 ms	8.939us	250 ms	0.977 ms
011	F _{OSC} /16	1.14 ms	4.470us	125 ms	0.488 ms
100	F _{OSC} /8	0.57 ms	2.235us	62.5 ms	0.244 ms
101	F _{OSC} /4	0.29 ms	1.117us	31.25 ms	0.122 ms
110	F _{OSC} /2	0.14 ms	0.587us	15.63 ms	0.061 ms
111	F _{OSC}	71.5 us	0.279us	7.81ms	0.03 ms

TC0_Counter=6-bit, TC0X8=1

TC0RATE	TC0CLOCK	High speed mode (F _{OSC} = 3.58MHz)		Low speed mode (F _{OSC} = 32768Hz)	
		Max overflow interval	One step = max/64	Max overflow interval	One step = max/64
000	F _{OSC} /128	2.29 ms	35.754us	250 ms	3.91 ms
001	F _{OSC} /64	1.14 ms	17.877us	125 ms	1.95 ms
010	F _{OSC} /32	0.57 ms	8.939us	62.5 ms	0.977 ms
011	F _{OSC} /16	0.29 ms	4.470us	31.25 ms	0.488 ms
100	F _{OSC} /8	0.14 ms	2.235us	15.63 ms	0.244 ms
101	F _{OSC} /4	71.5 us	1.117us	7.81ms	0.122 ms
110	F _{OSC} /2	35.75 us	0.587us	3.905 ms	0.061 ms
111	F _{OSC}	17.875 us	0.279us	1.953 ms	0.03 ms

TC0_Counter=5-bit, TC0X8=1

TC0RATE	TC0CLOCK	High speed mode (F _{OSC} = 3.58MHz)		Low speed mode (F _{OSC} = 32768Hz)	
		Max overflow interval	One step = max/32	Max overflow interval	One step = max/32
000	F _{OSC} /128	1.14 ms	35.754us	125 ms	3.91 ms
001	F _{OSC} /64	0.57 ms	17.877us	62.5 ms	1.95 ms
010	F _{OSC} /32	0.29 ms	8.939us	31.25 ms	0.977 ms
011	F _{OSC} /16	0.14 ms	4.470us	15.63 ms	0.488 ms
100	F _{OSC} /8	71.5 us	2.235us	7.81ms	0.244 ms
101	F _{OSC} /4	35.75 us	1.117us	3.905 ms	0.122 ms
110	F _{OSC} /2	17.875 us	0.587us	1.953 ms	0.061 ms
111	F _{OSC}	8.936 us	0.279us	0.976 ms	0.03 ms

TC0_Counter=4-bit, TC0X8=1

TC0RATE	TC0CLOCK	High speed mode (F _{OSC} = 3.58MHz)		Low speed mode (F _{OSC} = 32768Hz)	
		Max overflow interval	One step = max/16	Max overflow interval	One step = max/16
000	F _{OSC} /128	0.57 ms	35.754us	62.5 ms	3.91 ms
001	F _{OSC} /64	0.29 ms	17.877us	31.25 ms	1.95 ms
010	F _{OSC} /32	0.14 ms	8.939us	15.63 ms	0.977 ms
011	F _{OSC} /16	71.5 us	4.470us	7.81ms	0.488 ms
100	F _{OSC} /8	35.75 us	2.235us	3.905 ms	0.244 ms
101	F _{OSC} /4	17.875 us	1.117us	1.953 ms	0.122 ms
110	F _{OSC} /2	8.936 us	0.587us	0.976 ms	0.061 ms
111	F _{OSC}	4.468 us	0.279us	0.488 ms	0.03 ms

Table 8-2. The Timing Table of Timer Count TC0

TC0R AUTO-LOAD REGISTER

TC0R is an 8-bit register for the TC0 auto-reload function. TC0R's value applies to TC0OUT and PWM0OUT functions. Under TC0OUT application, users must enable and set the TC0R register. The main purpose of TC0R is as following.

- Store the auto-reload value and set into TC0C when the TC0C overflow. (ALOAD0 = 1).
- Store the duty value of PWM0OUT function.

TC0R initial value = xxxx xxxx

0CDH	Bit 7	Bit 6	Bit 5	Bit 4	Bit 3	Bit 2	Bit 1	Bit 0
TC0R	TC0R7	TC0R6	TC0R5	TC0R4	TC0R3	TC0R2	TC0R1	TC0R0
	W	W	W	W	W	W	W	W

The equation of TC0R initial value is like TC0C as following.

$$TC0R \text{ initial value} = N - (TC0 \text{ interrupt interval time} * \text{input clock})$$

Which N is determinate by code option: TC0_Counter

TC0_Counter	N	Max. TC0R value
8-bit	256	255
6-bit	64	63
5-bit	32	31
4-bit	16	15

- **Note: The TC0R must small or equal than Max. TC0R value.**
- **Note: The TC0R is write-only register can't be process by INCMS, DECMS instructions.**

TC0 TIMER COUNTER OPERATION SEQUENCE

The TC0 timer counter's sequence of operation can be following.

- Set the TC0C initial value to setup the interval time.
- Set the TC0ENB to be "1" to enable TC0 timer counter.
- TC0C is incremented by one with each clock pulse which frequency is corresponding to TC0M selection.
- TC0C overflows when TC0C from FFH to 00H.
- When TC0C overflow occurs, the TC0IRQ flag is set to be "1" by hardware.
- Execute the interrupt service routine.
- Users reset the TC0C value and resume the TC0 timer operation.

➤ Example: Setup the TC0M and TC0C without auto-reload function.(TC0_Counter=8-bit)

```

B0BCLR    FTC0X8           ; To select TC0=Fcpu/2 as clock source
B0BCLR    FTC0IEN         ; To disable TC0 interrupt service
B0BCLR    FTC0ENB         ; To disable TC0 timer
MOV       A,#20H          ;
B0MOV     TC0M,A          ; To set TC0 clock = FCPU / 64
MOV       A,#74H          ; To set TC0C initial value = 74H
B0MOV     TC0C,A          ;(To set TC0 interval = 10 ms)

B0BSET    FTC0IEN         ; To enable TC0 interrupt service
B0BCLR    FTC0IRQ         ; To clear TC0 interrupt request
B0BSET    FTC0ENB         ; To enable TC0 timer

```

➤ Example: Setup the TC0M and TC0C with auto-reload function. (TC0_Counter=8-bit)

```

B0BCLR    FTC0X8           ; To select TC0=Fcpu/2 as clock source
B0BCLR    FTC0IEN         ; To disable TC0 interrupt service
B0BCLR    FTC0ENB         ; To disable TC0 timer
MOV       A,#20H          ;
B0MOV     TC0M,A          ; To set TC0 clock = FCPU / 64
MOV       A,#74H          ; To set TC0C initial value = 74H
B0MOV     TC0C,A          ; (To set TC0 interval = 10 ms)
B0MOV     TC0R,A          ; To set TC0R auto-reload register

B0BSET    FTC0IEN         ; To enable TC0 interrupt service
B0BCLR    FTC0IRQ         ; To clear TC0 interrupt request
B0BSET    FTC0ENB         ; To enable TC0 timer
B0BSET    ALOAD0          ; To enable TC0 auto-reload function.

```

➔ **Example: TC0 interrupt service routine without auto-reload function. (TC0_Counter=8-bit)**

```

INT_SERVICE:
    ORG          8          ; Interrupt vector
    JMP          INT_SERVICE

    B0XCH       A, ACCBUF   ; Store ACC value.
    B0MOV       A, PFLAG
    B0MOV       PFLAGBUF, A

    B0BTS1     FTC0IRQ     ; Check TC0IRQ
    JMP         EXIT_INT   ; TC0IRQ = 0, exit interrupt vector

    B0BCLR     FTC0IRQ     ; Reset TC0IRQ
    MOV        A,#74H     ; Reload TC0C
    B0MOV     TC0C,A

    .          .          ; TC0 interrupt service routine
    .          .
    JMP        EXIT_INT   ; End of TC0 interrupt service routine and exit interrupt
                          ; vector

EXIT_INT:
    .          .
    .          .
    B0MOV     A, PFLAGBUF
    B0MOV     PFLAG, A
    B0XCH     A, ACCBUF   ; Restore ACC value.

    RETI       ; Exit interrupt vector
    
```

➔ **Example: TC0 interrupt service routine with auto-reload. (TC0_Counter=8-bit)**

```

INT_SERVICE:
    ORG          8          ; Interrupt vector
    JMP          INT_SERVICE

    B0XCH       A, ACCBUF   ; Store ACC value.
    B0MOV       A, PFLAG
    B0MOV       PFLAGBUF, A

    B0BTS1     FTC0IRQ     ; Check TC0IRQ
    JMP         EXIT_INT   ; TC0IRQ = 0, exit interrupt vector

    B0BCLR     FTC0IRQ     ; Reset TC0IRQ
    .          .          ; TC0 interrupt service routine
    .          .
    JMP        EXIT_INT   ; End of TC0 interrupt service routine and exit interrupt
                          ; vector

EXIT_INT:
    .          .
    .          .
    B0MOV     A, PFLAGBUF
    B0MOV     PFLAG, A
    B0XCH     A, ACCBUF   ; Restore ACC value.

    RETI       ; Exit interrupt vector
    
```

TC0 CLOCK FREQUENCY OUTPUT (BUZZER)

TC0 timer counter provides a frequency output function. By setting the TC0 clock frequency, the clock signal is output to P5.4 and the P5.4 general purpose I/O function is auto-disable. The TC0 output signal divides by 2. The TC0 clock has many combinations and easily to make difference frequency. This function applies as buzzer output to output multi-frequency.

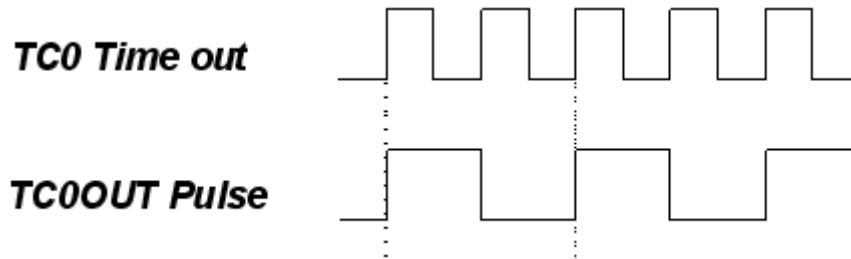

Figure 8-2. The TC0OUT Pulse Frequency

- ⇒ **Example:** Setup TC0OUT output from TC0 to TC0OUT (P5.4). The external high-speed clock is 4MHz. The TC0OUT frequency is 1KHz. Because the TC0OUT signal is divided by 2, set the TC0 clock to 2KHz. The TC0 clock source is from external oscillator clock. TC0 rate is $F_{CPU}/4$. The $TC0RATE2$ - $TC0RATE1 = 110$, $TC0C = TC0R = 131$, $TC0X8 = 0$, $TC0_Counter=8$ -bit

```

B0BCLR      FTC0X8           ; Set TC0X8 to 0
MOV         A,#01100000B
B0MOV       TC0M,A          ; Set the TC0 rate to Fcpu/4

MOV         A,#131
B0MOV       TC0C,A
B0MOV       TC0R,A

B0BSET      FTC0OUT         ; Enable TC0 output to P5.4 and disable P5.4 I/O function
B0BSET      FALOAD0         ; Enable TC0 auto-reload function
B0BSET      FTC0ENB         ; Enable TC0 timer

```

TC0OUT FREQUENCY TABLE

$F_{osc} = 4MHz$, $TC0\ Rate = F_{CPU}/8$, $TC0_Counter=8-bit$, $TC0X8=0$

TC0R	TC0OUT (KHz)	TC0R	TC0OUT (KHz)	TC0R	TC0OUT (KHz)	TC0R	TC0OUT (KHz)	TC0R	TC0OUT (KHz)
0	0.2441	56	0.3125	112	0.4340	168	0.7102	224	1.9531
1	0.2451	57	0.3141	113	0.4371	169	0.7184	225	2.0161
2	0.2461	58	0.3157	114	0.4401	170	0.7267	226	2.0833
3	0.2470	59	0.3173	115	0.4433	171	0.7353	227	2.1552
4	0.2480	60	0.3189	116	0.4464	172	0.7440	228	2.2321
5	0.2490	61	0.3205	117	0.4496	173	0.7530	229	2.3148
6	0.2500	62	0.3222	118	0.4529	174	0.7622	230	2.4038
7	0.2510	63	0.3238	119	0.4562	175	0.7716	231	2.5000
8	0.2520	64	0.3255	120	0.4596	176	0.7813	232	2.6042
9	0.2530	65	0.3272	121	0.4630	177	0.7911	233	2.7174
10	0.2541	66	0.3289	122	0.4664	178	0.8013	234	2.8409
11	0.2551	67	0.3307	123	0.4699	179	0.8117	235	2.9762
12	0.2561	68	0.3324	124	0.4735	180	0.8224	236	3.1250
13	0.2572	69	0.3342	125	0.4771	181	0.8333	237	3.2895
14	0.2583	70	0.3360	126	0.4808	182	0.8446	238	3.4722
15	0.2593	71	0.3378	127	0.4845	183	0.8562	239	3.6765
16	0.2604	72	0.3397	128	0.4883	184	0.8681	240	3.9063
17	0.2615	73	0.3415	129	0.4921	185	0.8803	241	4.1667
18	0.2626	74	0.3434	130	0.4960	186	0.8929	242	4.4643
19	0.2637	75	0.3453	131	0.5000	187	0.9058	243	4.8077
20	0.2648	76	0.3472	132	0.5040	188	0.9191	244	5.2083
21	0.2660	77	0.3492	133	0.5081	189	0.9328	245	5.6818
22	0.2671	78	0.3511	134	0.5123	190	0.9470	246	6.2500
23	0.2682	79	0.3531	135	0.5165	191	0.9615	247	6.9444
24	0.2694	80	0.3551	136	0.5208	192	0.9766	248	7.8125
25	0.2706	81	0.3571	137	0.5252	193	0.9921	249	8.9286
26	0.2717	82	0.3592	138	0.5297	194	1.0081	250	10.4167
27	0.2729	83	0.3613	139	0.5342	195	1.0246	251	12.5000
28	0.2741	84	0.3634	140	0.5388	196	1.0417	252	15.6250
29	0.2753	85	0.3655	141	0.5435	197	1.0593	253	20.8333
30	0.2765	86	0.3676	142	0.5482	198	1.0776	254	31.2500
31	0.2778	87	0.3698	143	0.5531	199	1.0965	255	62.5000
32	0.2790	88	0.3720	144	0.5580	200	1.1161		
33	0.2803	89	0.3743	145	0.5631	201	1.1364		
34	0.2815	90	0.3765	146	0.5682	202	1.1574		
35	0.2828	91	0.3788	147	0.5734	203	1.1792		
36	0.2841	92	0.3811	148	0.5787	204	1.2019		
37	0.2854	93	0.3834	149	0.5841	205	1.2255		
38	0.2867	94	0.3858	150	0.5896	206	1.2500		
39	0.2880	95	0.3882	151	0.5952	207	1.2755		
40	0.2894	96	0.3906	152	0.6010	208	1.3021		
41	0.2907	97	0.3931	153	0.6068	209	1.3298		
42	0.2921	98	0.3956	154	0.6127	210	1.3587		
43	0.2934	99	0.3981	155	0.6188	211	1.3889		
44	0.2948	100	0.4006	156	0.6250	212	1.4205		
45	0.2962	101	0.4032	157	0.6313	213	1.4535		
46	0.2976	102	0.4058	158	0.6378	214	1.4881		
47	0.2990	103	0.4085	159	0.6443	215	1.5244		
48	0.3005	104	0.4112	160	0.6510	216	1.5625		
49	0.3019	105	0.4139	161	0.6579	217	1.6026		
50	0.3034	106	0.4167	162	0.6649	218	1.6447		
51	0.3049	107	0.4195	163	0.6720	219	1.6892		
52	0.3064	108	0.4223	164	0.6793	220	1.7361		
53	0.3079	109	0.4252	165	0.6868	221	1.7857		
54	0.3094	110	0.4281	166	0.6944	222	1.8382		
55	0.3109	111	0.4310	167	0.7022	223	1.8939		

Table 8-3. TC0OUT Frequency Table for $F_{osc} = 4MHz$, $TC0\ Rate = F_{CPU}/8$

$F_{OSC} = 16\text{MHz}$, $TC0 \text{ Rate} = F_{CPU}/8$, $TC0_Counter=8\text{-bit}$

TC0R	TC0OUT (KHz)	TC0R	TC0OUT (KHz)	TC0R	TC0OUT (KHz)	TC0R	TC0OUT (KHz)	TC0R	TC0OUT (KHz)
0	0.9766	56	1.2500	112	1.7361	168	2.8409	224	7.8125
1	0.9804	57	1.2563	113	1.7483	169	2.8736	225	8.0645
2	0.9843	58	1.2626	114	1.7606	170	2.9070	226	8.3333
3	0.9881	59	1.2690	115	1.7730	171	2.9412	227	8.6207
4	0.9921	60	1.2755	116	1.7857	172	2.9762	228	8.9286
5	0.9960	61	1.2821	117	1.7986	173	3.0120	229	9.2593
6	1.0000	62	1.2887	118	1.8116	174	3.0488	230	9.6154
7	1.0040	63	1.2953	119	1.8248	175	3.0864	231	10.0000
8	1.0081	64	1.3021	120	1.8382	176	3.1250	232	10.4167
9	1.0121	65	1.3089	121	1.8519	177	3.1646	233	10.8696
10	1.0163	66	1.3158	122	1.8657	178	3.2051	234	11.3636
11	1.0204	67	1.3228	123	1.8797	179	3.2468	235	11.9048
12	1.0246	68	1.3298	124	1.8939	180	3.2895	236	12.5000
13	1.0288	69	1.3369	125	1.9084	181	3.3333	237	13.1579
14	1.0331	70	1.3441	126	1.9231	182	3.3784	238	13.8889
15	1.0373	71	1.3514	127	1.9380	183	3.4247	239	14.7059
16	1.0417	72	1.3587	128	1.9531	184	3.4722	240	15.6250
17	1.0460	73	1.3661	129	1.9685	185	3.5211	241	16.6667
18	1.0504	74	1.3736	130	1.9841	186	3.5714	242	17.8571
19	1.0549	75	1.3812	131	2.0000	187	3.6232	243	19.2308
20	1.0593	76	1.3889	132	2.0161	188	3.6765	244	20.8333
21	1.0638	77	1.3966	133	2.0325	189	3.7313	245	22.7273
22	1.0684	78	1.4045	134	2.0492	190	3.7879	246	25.0000
23	1.0730	79	1.4124	135	2.0661	191	3.8462	247	27.7778
24	1.0776	80	1.4205	136	2.0833	192	3.9063	248	31.2500
25	1.0823	81	1.4286	137	2.1008	193	3.9683	249	35.7143
26	1.0870	82	1.4368	138	2.1186	194	4.0323	250	41.6667
27	1.0917	83	1.4451	139	2.1368	195	4.0984	251	50.0000
28	1.0965	84	1.4535	140	2.1552	196	4.1667	252	62.5000
29	1.1013	85	1.4620	141	2.1739	197	4.2373	253	83.3333
30	1.1062	86	1.4706	142	2.1930	198	4.3103	254	125.0000
31	1.1111	87	1.4793	143	2.2124	199	4.3860	255	250.0000
32	1.1161	88	1.4881	144	2.2321	200	4.4643		
33	1.1211	89	1.4970	145	2.2523	201	4.5455		
34	1.1261	90	1.5060	146	2.2727	202	4.6296		
35	1.1312	91	1.5152	147	2.2936	203	4.7170		
36	1.1364	92	1.5244	148	2.3148	204	4.8077		
37	1.1416	93	1.5337	149	2.3364	205	4.9020		
38	1.1468	94	1.5432	150	2.3585	206	5.0000		
39	1.1521	95	1.5528	151	2.3810	207	5.1020		
40	1.1574	96	1.5625	152	2.4038	208	5.2083		
41	1.1628	97	1.5723	153	2.4272	209	5.3191		
42	1.1682	98	1.5823	154	2.4510	210	5.4348		
43	1.1737	99	1.5924	155	2.4752	211	5.5556		
44	1.1792	100	1.6026	156	2.5000	212	5.6818		
45	1.1848	101	1.6129	157	2.5253	213	5.8140		
46	1.1905	102	1.6234	158	2.5510	214	5.9524		
47	1.1962	103	1.6340	159	2.5773	215	6.0976		
48	1.2019	104	1.6447	160	2.6042	216	6.2500		
49	1.2077	105	1.6556	161	2.6316	217	6.4103		
50	1.2136	106	1.6667	162	2.6596	218	6.5789		
51	1.2195	107	1.6779	163	2.6882	219	6.7568		
52	1.2255	108	1.6892	164	2.7174	220	6.9444		
53	1.2315	109	1.7007	165	2.7473	221	7.1429		
54	1.2376	110	1.7123	166	2.7778	222	7.3529		
55	1.2438	111	1.7241	167	2.8090	223	7.5758		

Table 8-4. TC0OUT Frequency Table for $F_{OSC} = 16\text{MHz}$, $TC0 \text{ Rate} = F_{CPU}/8$

TIMER COUNTER 1 (TC1)

OVERVIEW

The timer counter 1 (TC1) is used to generate an interrupt request when a specified time interval has elapsed. TC1 has an auto re-loadable counter that consists of two parts: an 8-bit reload register (TC1R) into which you write the counter

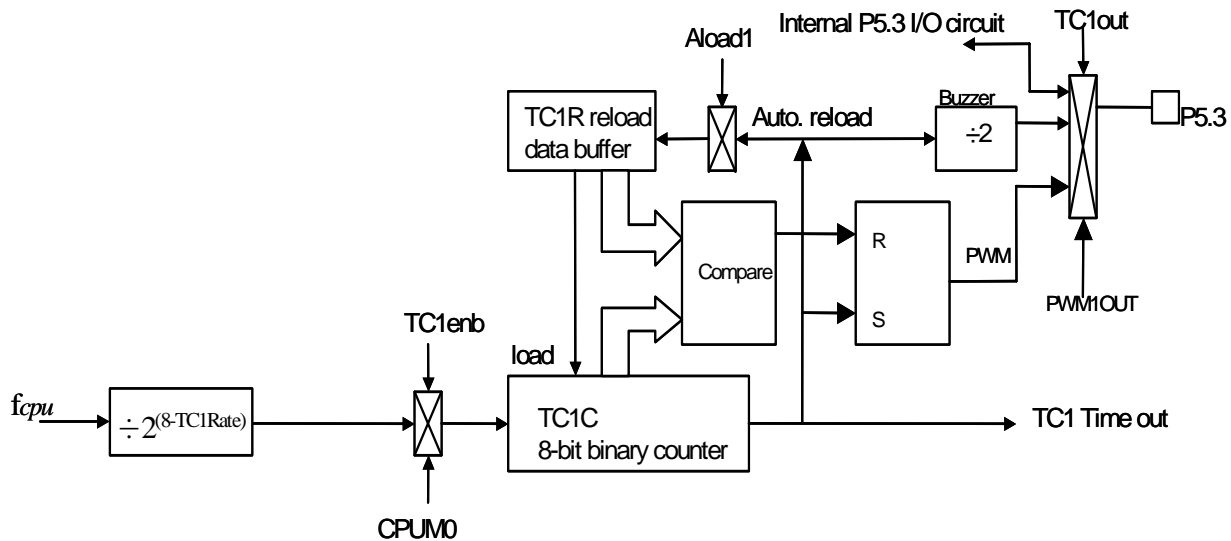

reference value, and an 8-bit counter register (TC1C) whose value is automatically incremented by counter logic.

Figure 8-3. Timer Count TC1 Block Diagram

The main purposes of the TC1 timer is as following.

- **8-bit programmable timer:** Generates interrupts at specific time intervals based on the selected clock frequency.
- **Arbitrary frequency output (Buzzer output):** Outputs selectable clock frequencies to the BZ1 pin (P5.3).
- **PWM function:** PWM output can be generated by the PWM1OUT bit and output to PWM1OUT pin (P5.3).

TC1M MODE REGISTER

The TC1M is the timer mode register, which is an 8-bit read/write register. By loading different value into the TC1M register, users can modify the timer counter clock frequency dynamically when program executing.

Eight rates for TC1 timer can be selected by TC1RATE0 ~ TC1RATE2 and TC1X8 bits of T0M register. If TC1X8=1 the TC1 will faster 8 times than TC1X8=0 (initial value). The 7th bit of TC1M named TC1ENB is the control bit to start TC1 timer.

TC1M initial value = 0000 0000

0DCH	Bit 7	Bit 6	Bit 5	Bit 4	Bit 3	Bit 2	Bit 1	Bit 0
TC1M	TC1ENB	TC1RATE2	TC1RATE1	TC1RATE0	TC1CKS	ALOAD1	TC1OUT	PWM1OUT
	R/W	R/W	R/W	R/W	R/W	R/W	R/W	R/W

Bit7 **TC1ENB**: TC1 counter/BZ1/PWM1OUT enable bit.
0 = disable,
1 = enable.

Bit [6:4] **TC1RATE [2:0]**: TC1 clock source selection bits. TC1X8 is bit 3 of T0M register.

TC1RATE [2:0]	TC1 Clock Source	
	TC1X8 = 0	TC1X8 = 1
000	$F_{CPU}/256 = F_{OSC}/1024$	$F_{OSC}/128$
001	$F_{CPU}/128 = F_{OSC}/512$	$F_{OSC}/64$
...
110	$F_{CPU}/4 = F_{OSC}/16$	$F_{OSC}/2$
111	$F_{CPU}/2 = F_{OSC}/8$	F_{OSC}

Note: $F_{CPU} = F_{OSC} / 4$

Bit3 **TC1CKS**: TC1 clock source select bit. "0" = F_{CPU} , "1" = external clock comes form INT1/P0.1 pin. TC1 will be an event counter.

Bit2 **ALOAD1**: TC1 auto-reload function control bit.
0 = none auto-reload
1 = auto-reload.

Bit1 **TC01UT**: TC1 time-out toggle signal output control bit.
0 = To disable TC1 signal output and to enable P5.3's I/O function,
1 = To enable TC1's signal output and to disable P5.3's I/O function. (Auto-disable the PWM0OUT function.)

Bit0 **PWM1OUT**: TC1's PWM output control bit.
0 = To disable the PWM output,
1 = To enable the PWM output (The TC1OUT control bit must = 0)

➤ **Note: Note: When TC1CKS=1, TC1 became an external event counter. No more P0.1 interrupt request will be raised. (P01IRQ will be always 0)**

TC1C COUNTING REGISTER

TC1C is an 8-bit counter register for the timer counter (TC1). TC1C must be reset whenever the TC1ENB is set "1" to start the timer. TC0C is incremented by one with a clock pulse which the frequency is determined by TC0RATE0 ~ TC0RATE2. When TC0C has incremented to "0FFH", it will be cleared to "00H" in next clock and an overflow is generated. Under TC1 interrupt service request (TC1IEN) enable condition, the TC1 interrupt request flag will be set "1" and the system executes the interrupt service routine.

TC1C initial value = xxxx xxxx

ODDH	Bit 7	Bit 6	Bit 5	Bit 4	Bit 3	Bit 2	Bit 1	Bit 0
TC1C	TC1C7	TC1C6	TC1C5	TC1C4	TC1C3	TC1C2	TC1C1	TC1C0
	R/W	R/W	R/W	R/W	R/W	R/W	R/W	R/W

TC1 OVERFLOW TIME

TC1 rate is determinate by TC1Rate and Code Option TC1_Counter, TC1Rate can set TC1 clock frequency from F_{CPU} and TC1_Counter set TC1 became 8-bit, 6-bit, 5-bit or 4-bit counter. The equation of TC1C initial value is as following.

$$TC1C \text{ initial value} = N - (TC1 \text{ interrupt interval time} * \text{input clock})$$

Which N is determinate by code option: TC1_Counter

TC1_Counter	N	Max. TC1C value
8-bit	256	255
6-bit	64	63
5-bit	32	31
4-bit	16	15

➤ **Note: The TC1C must small or equal than Max. TC1 value.**

➤ **Example: To set 10ms interval time for TC1 interrupt at F_{OSC} = 3.58MHz.**

$$TC1C \text{ value (74H)} = 256 - (10ms * F_{CPU} / 64) \quad (TC1RATE=010, TC1_Counter=8\text{-bit}, TC1X8=0)$$

$$\begin{aligned}
 TC1C \text{ initial value} &= 256 - (TC0 \text{ interrupt interval time} * \text{input clock}) \\
 &= 256 - (10ms * 3.58 * 10^6 / 4 / 64) \\
 &= 256 - (10^{-2} * 3.58 * 10^6 / 4 / 64) \\
 &= 116 \\
 &= 74H
 \end{aligned}$$

➤ **Example: To set 1.25ms interval time for TC1 interrupt at F_{OSC} = 3.58MHz.**

$$TC1C \text{ value (74H)} = 256 - (10ms * f_{cpu} / 64) \quad (TC1RATE=010, TC1_Counter=8\text{-bit}, TC1X8=1)$$

$$\begin{aligned}
 TC1C \text{ initial value} &= 256 - (TC0 \text{ interrupt interval time} * \text{input clock}) \\
 &= 256 - (1.25ms * 3.58 * 10^6 / 32) \\
 &= 256 - (0.00125 * 3.58 * 10^6 / 32) \\
 &= 116 \\
 &= 74H
 \end{aligned}$$

➤ **Example: To set 1ms interval time for TC1 interrupt at F_{OSC} = 3.58MHz.**

$$TC1C \text{ value (32H)} = 64 - (1ms * F_{CPU} / 64) \quad (TC1RATE=010, TC1_COUNTER=6\text{-bit}, TC1X8=0)$$

$$\begin{aligned}
 TC1C \text{ initial value} &= 64 - (TC0 \text{ interrupt interval time} * \text{input clock}) \\
 &= 64 - (1ms * 3.58 * 10^6 / 4 / 64) \\
 &= 64 - (1^{-2} * 3.58 * 10^6 / 4 / 64) \\
 &= 64-14 \\
 &= 32H
 \end{aligned}$$

TC1_Counter=8-bit, TC1X8=0

TC1RATE	TC1CLOCK	High speed mode ($F_{CPU} = 3.58\text{MHz} / 4$)		Low speed mode ($F_{CPU} = 32768\text{Hz} / 4$)	
		Max overflow interval	One step = max/256	Max overflow interval	One step = max/256
000	$F_{CPU} / 256$	73.2 ms	286us	8000 ms	31.25 ms
001	$F_{CPU} / 128$	36.6 ms	143us	4000 ms	15.63 ms
010	$F_{CPU} / 64$	18.3 ms	71.5us	2000 ms	7.8 ms
011	$F_{CPU} / 32$	9.15 ms	35.8us	1000 ms	3.9 ms
100	$F_{CPU} / 16$	4.57 ms	17.9us	500 ms	1.95 ms
101	$F_{CPU} / 8$	2.28 ms	8.94us	250 ms	0.98 ms
110	$F_{CPU} / 4$	1.14 ms	4.47us	125 ms	0.49 ms
111	$F_{CPU} / 2$	0.57 ms	2.23us	62.5 ms	0.24 ms

TC1_Counter=6-bit, TC1X8=0

TC1RATE	TC1CLOCK	High speed mode ($F_{CPU} = 3.58\text{MHz} / 4$)		Low speed mode ($F_{CPU} = 32768\text{Hz} / 4$)	
		Max overflow interval	One step = max/64	Max overflow interval	One step = max/64
000	$F_{CPU} / 256$	18.3 ms	286us	2000 ms	31.25 ms
001	$F_{CPU} / 128$	9.15 ms	143us	1000 ms	15.63 ms
010	$F_{CPU} / 64$	4.57 ms	71.5us	500 ms	7.8 ms
011	$F_{CPU} / 32$	2.28 ms	35.8us	250 ms	3.9 ms
100	$F_{CPU} / 16$	1.14 ms	17.9us	125 ms	1.95 ms
101	$F_{CPU} / 8$	0.57 ms	8.94us	62.5 ms	0.98 ms
110	$F_{CPU} / 4$	0.285 ms	4.47us	31.25 ms	0.49 ms
111	$F_{CPU} / 2$	0.143 ms	2.23us	15.63 ms	0.24 ms

TC1_Counter=5-bit, TC1X8=0

TC1RATE	TC1CLOCK	High speed mode ($F_{CPU} = 3.58\text{MHz} / 4$)		Low speed mode ($F_{CPU} = 32768\text{Hz} / 4$)	
		Max overflow interval	One step = max/32	Max overflow interval	One step = max/32
000	$F_{CPU} / 256$	9.15 ms	286us	1000 ms	31.25 ms
001	$F_{CPU} / 128$	4.57 ms	143us	500 ms	15.63 ms
010	$F_{CPU} / 64$	2.28 ms	71.5us	250 ms	7.8 ms
011	$F_{CPU} / 32$	1.14 ms	35.8us	125 ms	3.9 ms
100	$F_{CPU} / 16$	0.57 ms	17.9us	62.5 ms	1.95 ms
101	$F_{CPU} / 8$	0.285 ms	8.94us	31.25 ms	0.98 ms
110	$F_{CPU} / 4$	0.143 ms	4.47us	15.63 ms	0.49 ms
111	$F_{CPU} / 2$	71.25 us	2.23us	7.81 ms	0.24 ms

TC1_Counter=4-bit, TC1X8=0

TC1RATE	TC1CLOCK	High speed mode ($F_{CPU} = 3.58\text{MHz} / 4$)		Low speed mode ($F_{CPU} = 32768\text{Hz} / 4$)	
		Max overflow interval	One step = max/16	Max overflow interval	One step = max/16
000	$F_{CPU} / 256$	4.57 ms	286us	500 ms	31.25 ms
001	$F_{CPU} / 128$	2.28 ms	143us	250 ms	15.63 ms
010	$F_{CPU} / 64$	1.14 ms	71.5us	125 ms	7.8 ms
011	$F_{CPU} / 32$	0.57 ms	35.8us	62.5 ms	3.9 ms
100	$F_{CPU} / 16$	0.285 ms	17.9us	31.25 ms	1.95 ms
101	$F_{CPU} / 8$	0.143 ms	8.94us	15.63 ms	0.98 ms
110	$F_{CPU} / 4$	71.25 us	4.47us	7.81 ms	0.49 ms
111	$F_{CPU} / 2$	35.63 us	2.23us	3.91 ms	0.24 ms

TC1_Counter=8-bit, TC1X8=1

TC1RATE	TC1CLOCK	High speed mode (F _{OSC} = 3.58MHz)		Low speed mode (F _{OSC} = 32768Hz)	
		Max overflow interval	One step = max/256	Max overflow interval	One step = max/256
000	F _{OSC} /128	9.153 ms	35.754us	1000 ms	3.91 ms
001	F _{OSC} /64	4.58 ms	17.877us	500 ms	1.95 ms
010	F _{OSC} /32	2.29 ms	8.939us	250 ms	0.977 ms
011	F _{OSC} /16	1.14 ms	4.470us	125 ms	0.488 ms
100	F _{OSC} /8	0.57 ms	2.235us	62.5 ms	0.244 ms
101	F _{OSC} /4	0.29 ms	1.117us	31.25 ms	0.122 ms
110	F _{OSC} /2	0.14 ms	0.587us	15.63 ms	0.061 ms
111	F _{OSC}	71.5 us	0.279us	7.81ms	0.03 ms

TC1_Counter=6-bit, TC1X8=1

TC1RATE	TC1CLOCK	High speed mode (F _{OSC} = 3.58MHz)		Low speed mode (F _{OSC} = 32768Hz)	
		Max overflow interval	One step = max/64	Max overflow interval	One step = max/64
000	F _{OSC} /128	2.29 ms	35.754us	250 ms	3.91 ms
001	F _{OSC} /64	1.14 ms	17.877us	125 ms	1.95 ms
010	F _{OSC} /32	0.57 ms	8.939us	62.5 ms	0.977 ms
011	F _{OSC} /16	0.29 ms	4.470us	31.25 ms	0.488 ms
100	F _{OSC} /8	0.14 ms	2.235us	15.63 ms	0.244 ms
101	F _{OSC} /4	71.5 us	1.117us	7.81ms	0.122 ms
110	F _{OSC} /2	35.75 us	0.587us	3.905 ms	0.061 ms
111	F _{OSC}	17.875 us	0.279us	1.953 ms	0.03 ms

TC1_Counter=5-bit, TC1X8=1

TC1RATE	TC1CLOCK	High speed mode (F _{OSC} = 3.58MHz)		Low speed mode (F _{OSC} = 32768Hz)	
		Max overflow interval	One step = max/32	Max overflow interval	One step = max/32
000	F _{OSC} /128	1.14 ms	35.754us	125 ms	3.91 ms
001	F _{OSC} /64	0.57 ms	17.877us	62.5 ms	1.95 ms
010	F _{OSC} /32	0.29 ms	8.939us	31.25 ms	0.977 ms
011	F _{OSC} /16	0.14 ms	4.470us	15.63 ms	0.488 ms
100	F _{OSC} /8	71.5 us	2.235us	7.81ms	0.244 ms
101	F _{OSC} /4	35.75 us	1.117us	3.905 ms	0.122 ms
110	F _{OSC} /2	17.875 us	0.587us	1.953 ms	0.061 ms
111	F _{OSC}	8.936 us	0.279us	0.976 ms	0.03 ms

TC1_Counter=4-bit, TC1X8=1

TC1RATE	TC1CLOCK	High speed mode (F _{OSC} = 3.58MHz)		Low speed mode (F _{OSC} = 32768Hz)	
		Max overflow interval	One step = max/16	Max overflow interval	One step = max/16
000	F _{OSC} /128	0.57 ms	35.754us	62.5 ms	3.91 ms
001	F _{OSC} /64	0.29 ms	17.877us	31.25 ms	1.95 ms
010	F _{OSC} /32	0.14 ms	8.939us	15.63 ms	0.977 ms
011	F _{OSC} /16	71.5 us	4.470us	7.81ms	0.488 ms
100	F _{OSC} /8	35.75 us	2.235us	3.905 ms	0.244 ms
101	F _{OSC} /4	17.875 us	1.117us	1.953 ms	0.122 ms
110	F _{OSC} /2	8.936 us	0.587us	0.976 ms	0.061 ms
111	F _{OSC}	4.468 us	0.279us	0.488 ms	0.03 ms

Table 8-5. The Timing Table of Timer Count TC1

TC1R AUTO-LOAD REGISTER

TC1R is an 8-bit register for the TC1 auto-reload function. TC1R's value applies to TC1OUT and PWM1OUT functions. Under TC1OUT application, users must enable and set the TC1R register. The main purpose of TC1R is as following.

- Store the auto-reload value and set into TC1C when the TC1C overflow. (ALOAD1 = 1).
- Store the duty value of PWM1OUT function.

TC1R initial value = xxxx xxxx

ODEH	Bit 7	Bit 6	Bit 5	Bit 4	Bit 3	Bit 2	Bit 1	Bit 0
TC1R	TC1R7	TC1R6	TC1R5	TC1R4	TC1R3	TC1R2	TC1R1	TC1R0
	W	W	W	W	W	W	W	W

The equation of TC1R initial value is like TC1C as following.

$$TC1R \text{ initial value} = N - (TC1 \text{ interrupt interval time} * \text{input clock})$$

Which N is determinate by code option: TC1_Counter

TC0_Counter	N	Max. TC0R value
8-bit	256	255
6-bit	64	63
5-bit	32	31
4-bit	16	15

- **Note: The TC1R must small or equal than Max. TC1R value.**
- **Note: The TC1R is write-only register can't be process by INCMS, DECMS instructions.**

TC1 TIMER COUNTER OPERATION SEQUENCE

The TC1 timer's sequence of operation can be following.

- Set the TC1C initial value to setup the interval time.
- Set the TC1ENB to be "1" to enable TC1 timer counter.
- TC1C is incremented by one with each clock pulse which frequency is corresponding to TC1M selection.
- TC1C overflows if TC1C from FFH to 00H.
- When TC1C overflow occurs, the TC1IRQ flag is set to be "1" by hardware.
- Execute the interrupt service routine.
- Users reset the TC1C value and resume the TC1 timer operation.

➤ Example: Setup the TC1M and TC1C without auto-reload function.(TC1_Counter=8-bit, TC1X8=0)

```

B0BCLR      FTC1X8      ;
B0BCLR      FTC1IEN     ; To disable TC1 interrupt service
B0BCLR      FTC1ENB     ; To disable TC1 timer
MOV         A,#20H      ;
B0MOV       TC1M,A      ; To set TC1 clock = Fcpu / 64
MOV        A,#74H      ; To set TC1C initial value = 74H
B0MOV      TC1C,A      ;(To set TC1 interval = 10 ms)

B0BSET      FTC1IEN     ; To enable TC1 interrupt service
B0BCLR      FTC1IRQ     ; To clear TC1 interrupt request
B0BSET      FTC1ENB     ; To enable TC1 timer

```

➤ Example: Setup the TC1M and TC1C with auto-reload function. (TC1_Counter=8-bit, TC1X8=0)

```

B0BCLR      FTC1X8      ; To select TC1=Fcpu/2 as clock source
B0BCLR      FTC1IEN     ; To disable TC1 interrupt service
B0BCLR      FTC1ENB     ; To disable TC1 timer
MOV         A,#20H      ;
B0MOV       TC1M,A      ; To set TC1 clock = Fcpu / 64
MOV        A,#74H      ; To set TC1C initial value = 74H
B0MOV      TC1C,A      ; (To set TC1 interval = 10 ms)
B0MOV      TC1R,A      ; To set TC1R auto-reload register

B0BSET      FTC1IEN     ; To enable TC1 interrupt service
B0BCLR      FTC1IRQ     ; To clear TC1 interrupt request
B0BSET      FTC1ENB     ; To enable TC1 timer
B0BSET      ALOAD1      ; To enable TC1 auto-reload function.

```

⇒ Example: TC1 interrupt service routine without auto-reload function. (TC1_Counter=8-bit, TC1X8=0)

```

ORG          8                ; Interrupt vector
INT_SERVICE: JMP          INT_SERVICE

B0XCH        A, ACCBUF        ; Store ACC value.
B0MOV        A, PFLAG
B0MOV        PFLAGBUF, A

B0BTS1      FTC1IRQ          ; Check TC1IRQ
JMP          EXIT_INT        ; TC1IRQ = 0, exit interrupt vector

B0BCLR      FTC1IRQ          ; Reset TC1IRQ
MOV          A,#74H          ; Reload TC1C
B0MOV        TC1C,A
.           .                ; TC1 interrupt service routine
.           .
JMP          EXIT_INT        ; End of TC1 interrupt service routine and exit interrupt
                               vector
.           .
EXIT_INT:    B0MOV          A, PFLAGBUF
B0MOV        PFLAG, A
B0XCH        A, ACCBUF        ; Restore ACC value.

RETI        ; Exit interrupt vector

```

⇒ Example: TC1 interrupt service routine with auto-reload. (TC1_Counter=8-bit, TC1X8=0)

```

ORG          8                ; Interrupt vector
INT_SERVICE: JMP          INT_SERVICE

B0XCH        A, ACCBUF        ; Store ACC value.
B0MOV        A, PFLAG
B0MOV        PFLAGBUF, A

B0BTS1      FTC1IRQ          ; Check TC1IRQ
JMP          EXIT_INT        ; TC1IRQ = 0, exit interrupt vector

B0BCLR      FTC1IRQ          ; Reset TC1IRQ
.           .                ; TC1 interrupt service routine
.           .
JMP          EXIT_INT        ; End of TC1 interrupt service routine and exit interrupt
                               vector
.           .
EXIT_INT:    B0MOV          A, PFLAGBUF
B0MOV        PFLAG, A
B0XCH        A, ACCBUF        ; Restore ACC value.

RETI        ; Exit interrupt vector

```

TC1 CLOCK FREQUENCY OUTPUT (BUZZER)

TC1 timer counter provides a frequency output function. By setting the TC1 clock frequency, the clock signal is output to P5.3 and the P5.3 general purpose I/O function is auto-disable. The TC1 output signal divides by 2. The TC1 clock has many combinations and easily to make difference frequency. This function applies as buzzer output to output multi-frequency.

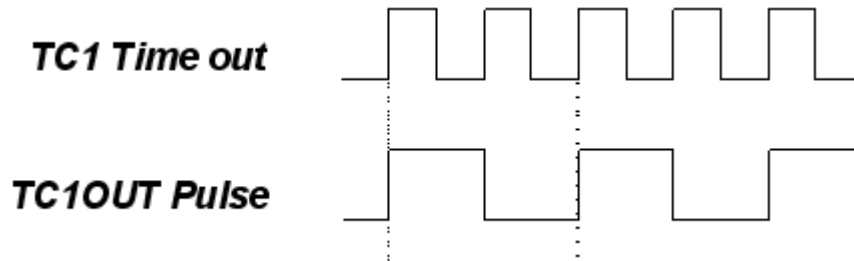

Figure 8-4 TC1OUT Pulse Frequency

- ⇒ **Example: Setup TC1OUT output from TC1 to TC1OUT (P5.3). The external high-speed clock is 4MHz. The TC1OUT frequency is 1KHz. Because the TC1OUT signal is divided by 2, set the TC1 clock to 2KHz. The TC1 clock source is from external oscillator clock. TC1 rate is $F_{cpu}/4$. The $TC1RATE2 \sim TC1RATE1 = 110$. $TC1C = TC1R = 131$. $TC1_Counter=8$ -bit, $TC1X8=0$**

```

MOV      A,#01100000B
B0MOV   TC1M,A           ; Set the TC1 rate to Fcpu/4

MOV      A,#131
B0MOV   TC1C,A
B0MOV   TC1R,A           ; Set the auto-reload reference value

B0BSET  FTC1OUT          ; Enable TC1 output to P5.3 and disable P5.3 I/O function
B0BSET  FALOAD1          ; Enable TC1 auto-reload function
B0BSET  FTC1ENB          ; Enable TC1 timer

```

PWM FUNCTION DESCRIPTION

OVERVIEW

PWM function is generated by TC0/TC1 timer counter and output the PWM signal to PWM0OUT pin (P5.4)/ PWM1OUT pin (P5.3). When code option TC0/TC1_Counter= 8-bit, the counter counts modulus 256, from 0-255, inclusive. The value of the 8-bit counter is compared to the contents of the reference register (TC0R/TC1R). When the reference register value (TC0R/TC1R) is equal to the counter value (TC0C/TC1C), the PWM output goes low. When the counter reaches zero, the PWM output is forced high. Table 7-4 listed the low-to-high ratio (duty) of the PWM0/PWM1 output.

For example, TC0_Counter=8-bit, all PWM outputs remain inactive during the first 256 input clock signals. Then, when the counter value (TC0C/TC1C) changes from FFH back to 00H, the PWM output is forced to high level. The pulse width ratio (duty cycle) is defined by the contents of the reference register (TC0R/TC1R) and is programmed in increments of 1:256. The 8-bit PWM data register TC0R/TC1R is write-only register. Different code option of TC0_Counter/TC1_Counter will cause different PWM Duty, so user can generate different PWM output by selection different TC0_Counter/TC1_Counter.

PWM output can be held at low level by continuously loading the reference register with 00H. Under PWM operating, to change the PWM's duty cycle is to modify the TC0R/TC1R.

TC0X8/TC1X8	PWM0 Frequency	PWM1 Frequency
0	$F_{osc}/(2^{10-TC0RATE})/N$	$F_{osc}/(2^{10-TC1RATE})/N$
1	$F_{osc}/(2^{7-TC0RATE})/N$	$F_{osc}/(2^{7-TC1RATE})/N$

The value of N depend on code option TC0_Counter/TC1_Counter

TC0_Counter/TC1_Counter	N	PWM Duty Cycle
8-bit	256	0/256 ~ 255/256
6-bit	64	0/64 ~ 63/64
5-bit	32	0/32 ~ 31/32
4-bit	16	0/16 ~ 15/16

Table 8-1. The PWM Frequency Calculation Formula

TC0X8 TC1X8	TC0_Counter TC1_Counter	TC0/TC1 Overflow boundary	PWM Duty Cycle	Max PWM Frequency ($F_{osc} = 4\text{MHz}$)	Note
0	8-bit	FFh to 00h	0/256 ~ 255/256	1.953125K	Overflow per 256 count
0	6-bit	3Fh to 40h	0/64 ~ 63/64	7.8125K	Overflow per 64 count
0	5-bit	1Fh to 20h	0/32 ~ 31/32	15.625K	Overflow per 32 count
0	4-bit	0Fh to 10h	0/16 ~ 15/16	31.25K	Overflow per 16 count
1	8-bit	FFh to 00h	0/256 ~ 255/256	15.625	Overflow per 256 count
1	6-bit	3Fh to 40h	0/64 ~ 63/64	62.5K	Overflow per 64 count
1	5-bit	1Fh to 20h	0/32 ~ 31/32	125K	Overflow per 32 count
1	4-bit	0Fh to 10h	0/16 ~ 15/16	250K	Overflow per 16 count

Table 8-2. The Maximum PWM Frequency Example (TC0RATE/TC1RATE = 111)

Reference Register Value (TC0R/TC1R)	TC0/1_Counter=8-bit Duty Cycle	TC0/1_Counter=6-bit Duty Cycle	TC0/1_Counter=5-bit Duty Cycle	TC0/1_Counter=4-bit Duty Cycle
0000 0000	0/256	0/64	0/32	0/16
0000 0001	1/256	1/64	1/32	1/16
0000 0010	2/256	2/64	2/32	2/16
...
0000 1110	14/256	14/64	14/32	14/16
0000 1111	15/256	15/64	15/32	15/16
0001 0000	16/256.	16/64	16/32	N/A
...	N/A
0001 1110	30/256	30/64	30/32	N/A
0001 1111	31/256	31/64	31/32	N/A
0010 0000	32/256.	32/64	N/A	N/A
...	N/A	N/A
0011 1110	62/256	62/64	N/A	N/A
0011 1111	63/256	63/64	N/A	N/A
0100 0000	64/256.	N/A	N/A	N/A
...	...	N/A	N/A	N/A
1111 1110	254/256	N/A	N/A	N/A
1111 1111	255/256	N/A	N/A	N/A

Table 8-3. The PWM Duty Cycle Table

➤ **Note: Functionality is not guaranteed in shaded area.**

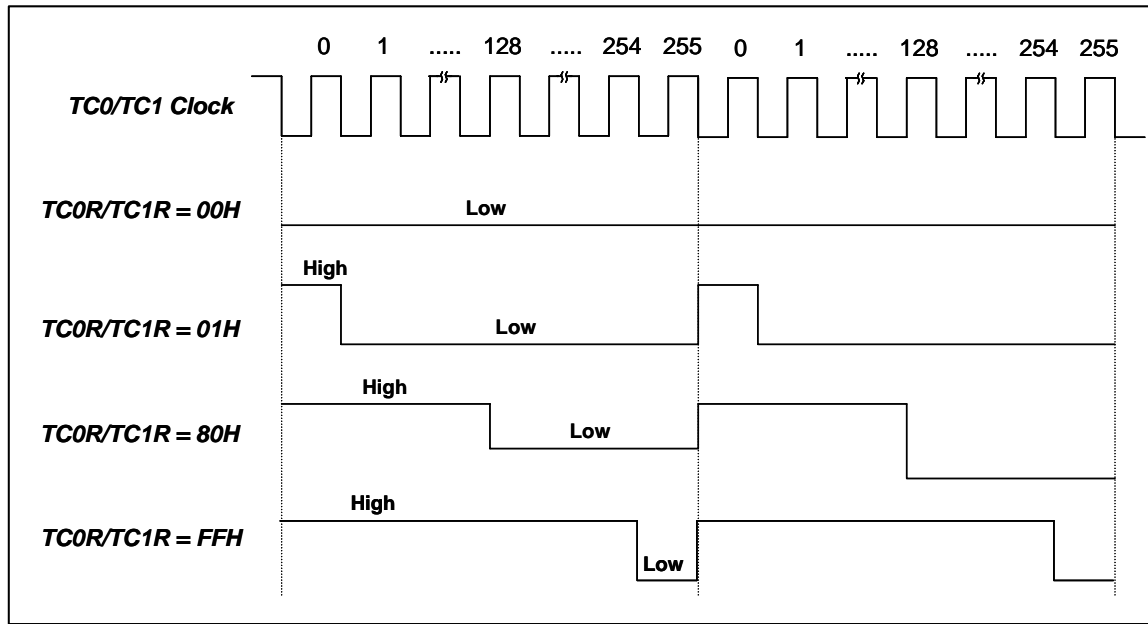

Figure 8-5 The Output of PWM with different TC0R/TC1R. (TC0/TC1_Counter=8-bit)

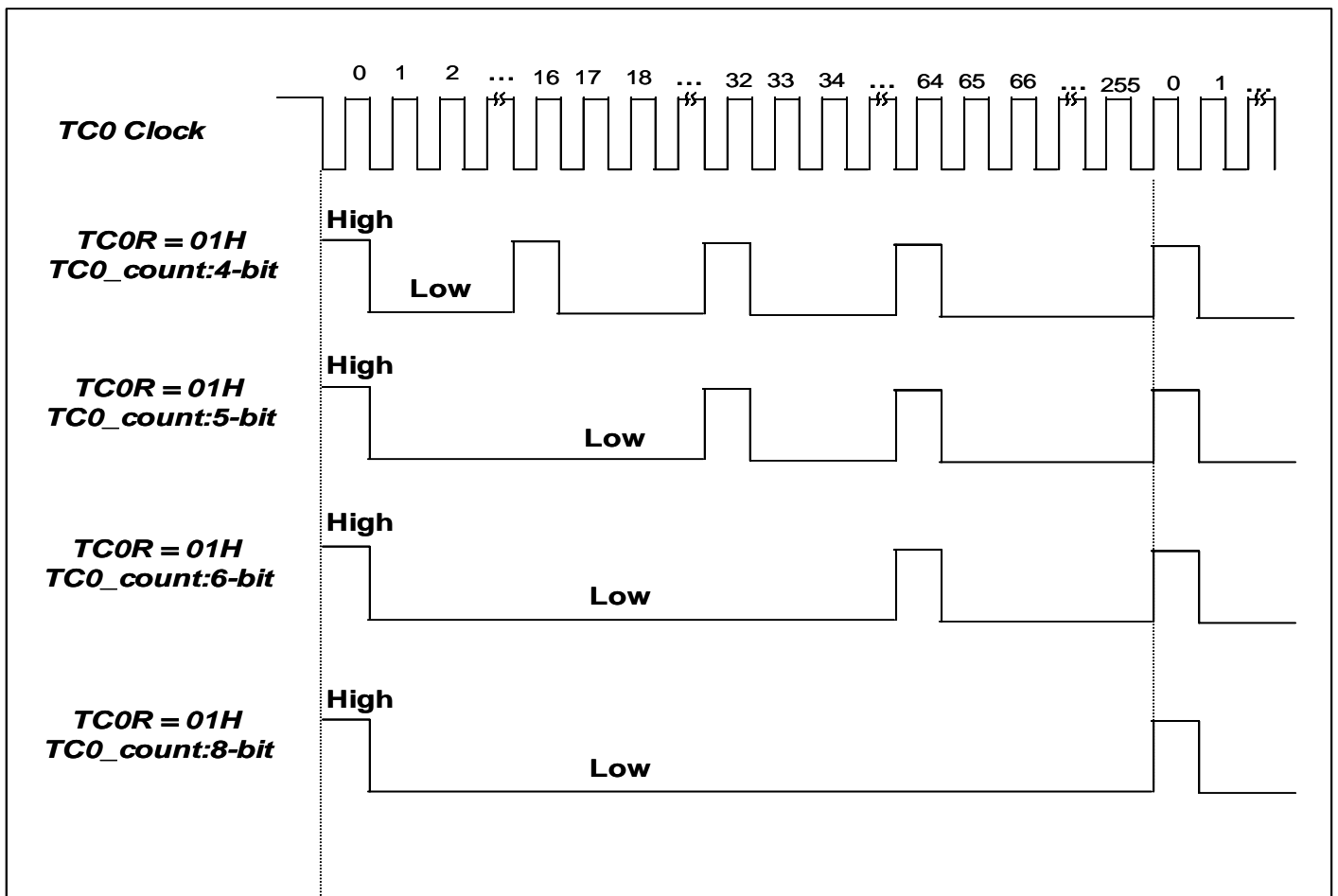

Figure 8-6 The Output of PWM with different TC0_Count

PWM PROGRAM DESCRIPTION

- **Example: Setup PWM0 output from TC0 to PWM0OUT (P5.4). The external high-speed oscillator clock is 4MHz. The duty of PWM is 30/256. The PWM frequency is about 1KHz. The PWM clock source is from external oscillator clock. TC0 rate is Fcpu/4. The TC0RATE2~TC0RATE1 = 110, TC0C = TC0R = 30, TC0X8 = 0, TC0_Counter=8-bit**

```

BOBCLR      FTC0X8          ;
MOV         A,#01100000B
B0MOV      TC0M,A          ; Set the TC0 rate to Fcpu/4
MOV         A,#0x00        ; First Time Initial TC0
B0MOV      TC0C,A
MOV         A,#30          ; Set the PWM duty to 30/256

B0MOV      TC0R,A

BOBCLR      FTC0OUT        ; Disable TC0OUT function.
BOBSET      FPWM0OUT       ; Enable PWM0 output to P5.4 and disable P5.4 I/O function
BOBSET      FTC0ENB        ; Enable TC0 timer

```

- **Note1: The TC0R and TC1R are write-only registers. Don't process them using INCMS, DECMS instructions.**
- **Note2: Set TC0C at initial is to make first duty-cycle correct. After TC0 is enabled, don't modify TC0R value to avoid duty cycle error of PWM output.**

- **Example: Modify TC0R/TC1R registers' value.**

```

MOV         A, #30H        ; Input a number using B0MOV instruction.
B0MOV      TC0R, A

INCMS      BUF0           ; Get the new TC0R value from the BUF0 buffer defined by
B0MOV      A, BUF0        ; programming.
B0MOV      TC0R, A

```

- **Note2: That is better to set the TC0C and TC0R value together when PWM0 duty modified. It protects the PWM0 signal no glitch as PWM0 duty changing. That is better to set the TC1C and TC1R value together when PWM1 duty modified. It protects the PWM1 signal no glitch as PWM1 duty changing.**
- **Note3: The TC0OUT function must be set "0" when PWM0 output enable. The TC1OUT function must be set "0" when PWM1 output enable.**
- **Note4: The PWM can work with interrupt request.**

9 INTERRUPT

OVERVIEW

The SN8P1900 provides 6 interrupt sources, including four internal interrupts (T0, TC0, TC1 & SIO) and two external interrupts (INT0 ~ INT1). These external interrupts can wakeup the chip from power down mode to high-speed normal mode. The external clock input pins of INT0/INT1 are shared with P0.0/P0.1 pins. Once interrupt service is executed, the GIE bit in STKP register will clear to "0" for stopping other interrupt request. When interrupt service exits, the GIE bit will set to "1" to accept the next interrupts' request. All of the interrupt request signals are stored in INTRQ register. The user can program the chip to check INTRQ's content for setting executive priority.

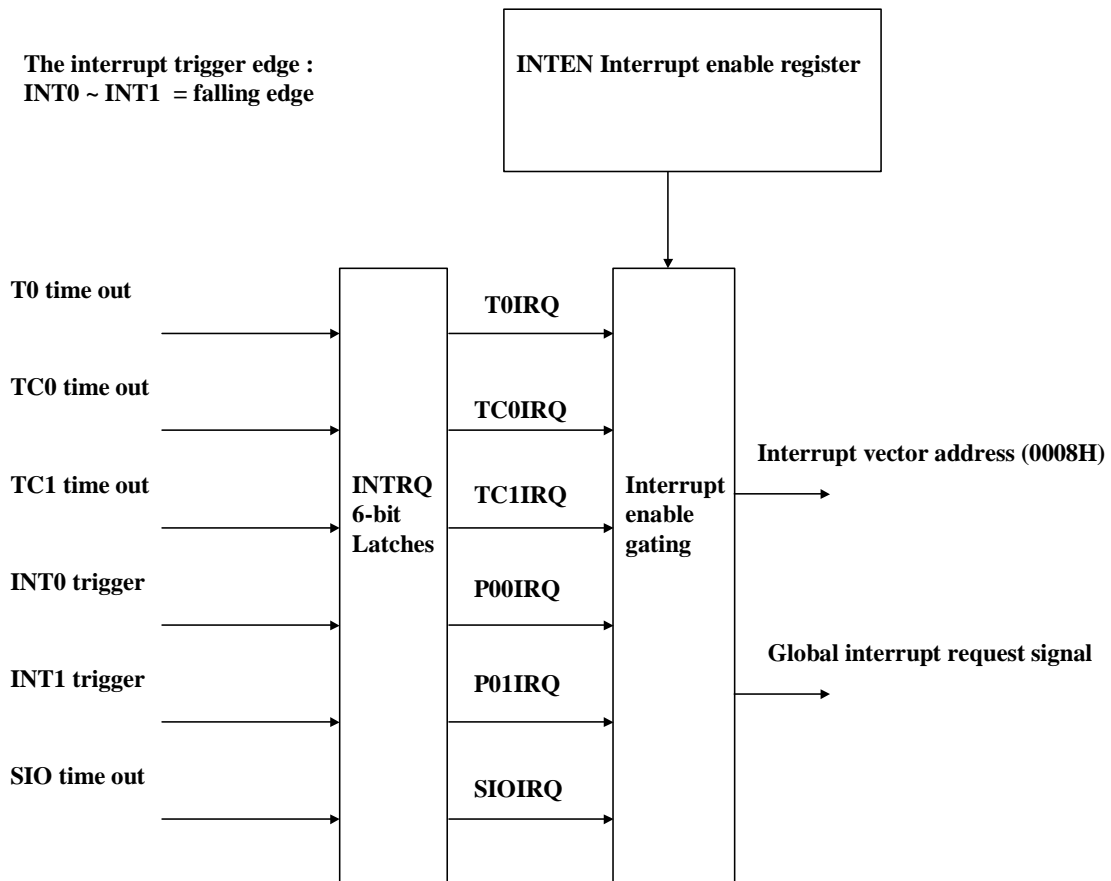

Figure 9-1. The 6 Interrupts of SN8P1900

➤ **Note:** The GIE bit must enable and all interrupt operations work.

INTEN INTERRUPT ENABLE REGISTER

INTEN is the interrupt request control register including four internal interrupts, three external interrupts and SIO interrupt enable control bits. One of the register to be set "1" is to enable the interrupt request function. Once of the interrupt occur, the program jump to ORG 8 to execute interrupt service routines. The program exits the interrupt service routine when the returning interrupt service routine instruction (RETI) is executed.

INTEN initial value = x000 0000

0C9H	Bit 7	Bit 6	Bit 5	Bit 4	Bit 3	Bit 2	Bit 1	Bit 0
INTEN	0	TC1IEN	TC0IEN	TOIEN	SIOIEN	0	P01IEN	P00IEN
	-	R/W	R/W	R/W	R/W	-	R/W	R/W

P00IEN : External P0.0 interrupt control bit. 0 = disable, 1 = enable.

P01IEN : External P0.1 interrupt control bit. 0 = disable, 1 = enable.

SIOIEN : SIO interrupt control bit. 0 = disable, 1 = enable.

TOIEN : T0 timer interrupt control bit. 0 = disable, 1 = enable.

TC0IEN : Timer 0 interrupt control bit. 0 = disable, 1 = enable.

TC1IEN : Timer 1 interrupt control bit. 0 = disable, 1 = enable.

INTRQ INTERRUPT REQUEST REGISTER

INTRQ is the interrupt request flag register. The register includes all interrupt request indication flags. Each one of these interrupt request occurs, the bit of the INTRQ register would be set "1". The INTRQ value needs to be clear by programming after detecting the flag. In the interrupt vector of program, users know the any interrupt requests occurring by the register and do the routine corresponding of the interrupt request.

INTRQ initial value = x000 0000

0C8H	Bit 7	Bit 6	Bit 5	Bit 4	Bit 3	Bit 2	Bit 1	Bit 0
INTRQ	0	TC1IRQ	TC0IRQ	TOIRQ	SIOIRQ	0	P01IRQ	P00IRQ
	-	R/W	R/W	R/W	R/W	-	R/W	R/W

Bit0 **P00IRQ**:External P0.0 interrupt request bit.
0 = non-request
1 = request.

Bit1 **P01IRQ**:External P0.1 interrupt request bit.
0 = non-request
1 = request.

Bit3 **SIOIRQ**: SIO interrupt request bit.
0 = non-request
1 = request.

Bit4 **TOIRQ**: T0 Timer interrupt request bit.
0 = non-request
1 = request.

Bit5 **TC0IRQ**:TC0 timer interrupt request controls bit.
0 = non request
1 = request.

Bit6 **TC1IRQ**:TC1 timer interrupt request controls bit.
0 = non request
1 = request.

When interrupt occurs, the related request bit of INTRQ register will be set to "1" no matter the related enable bit of INTEN register is enabled or disabled. If the related bit of INTEN = 1 and the related bit of INTRQ is also set to be "1". As the result, the system will execute the interrupt vector (ORG 8). If the related bit of INTEN = 0, moreover, the system won't execute interrupt vector even when the related bit of INTRQ is set to be "1". Users need to be cautious with the operation under multi-interrupt situation.

INTERRUPT OPERATION DESCRIPTION

SN8P1900 provides 6 interrupts. The operation of the 6 interrupts is as following.

GIE GLOBAL INTERRUPT OPERATION

GIE is the global interrupt control bit. All interrupts start work after the GIE = 1. It is necessary for interrupt service request. One of the interrupt requests occurs, and the program counter (PC) points to the interrupt vector (ORG 8) and the stack add 1 level.

STKP initial value = 0xxx 1111

0DFH	Bit 7	Bit 6	Bit 5	Bit 4	Bit 3	Bit 2	Bit 1	Bit 0
STKP	GIE	-	-	-	STKPB3	STKPB2	STKPB1	STKPB0
	R/W	-	-	-	R/W	R/W	R/W	R/W

GIE: Global interrupt control bit.
 0 = Disable
 1 = Enable.

➡ **Example: Set global interrupt control bit (GIE).**

```
BOBSET      FGIE          ; Enable GIE
```

➤ **Note: The GIE bit must enable and all interrupt operations work.**

INT0 (P0.0) INTERRUPT OPERATION

The P0.0 interrupt trigger direction is control by PEDGE register.

PEDGE initial value = 0xx0 0xxx

0BFH	Bit 7	Bit 6	Bit 5	Bit 4	Bit 3	Bit 2	Bit 1	Bit 0
PEDGE	PEDGEN	-	-	P00G1	P00G0	-	-	-
	R/W	-	-	R/W	R/W	-	-	-

Bit7 PEDGEN: Interrupt and wakeup trigger edge control bit.
 0 = Disable edge trigger function.
 Port 0: Low-level wakeup trigger and falling edge interrupt trigger.
 Port 1: Low-level wakeup trigger.
 1 = Enable edge trigger function.
 P0.0: Both Wakeup and interrupt trigger are controlled by P00G1 and P00G0 bits.
 P0.1: Both wakeup and interrupt trigger are Level change (falling or rising edge).
 Port 1: Wakeup trigger is Level change (falling or rising edge).

Bit[4:3] P00G[1:0]: Port 0.0 edge select bits.
 00 = reserved,
 01 = falling edge,
 10 = rising edge,
 11 = rising/falling bi-direction.

➔ **Example: INT0 interrupt request setup.**

```

BOBSET      FP00IEN      ; Enable INT0 interrupt service
BOBCLR      FP00IRQ      ; Clear INT0 interrupt request flag
BOBSET      FGIE         ; Enable GIE
    
```

➔ **Example: INT0 interrupt service routine.**

```

ORG      8      ; Interrupt vector
INT_SERVICE:
JMP      INT_SERVICE

BOXCH    A, ACCBUF      ; Store ACC value.
PUSH

BOBTS1   FP00IRQ      ; Check P00IRQ
JMP      EXIT_INT      ; P00IRQ = 0, exit interrupt vector

BOBCLR   FP00IRQ      ; Reset P00IRQ
:        .            ; INT0 interrupt service routine
:        .

EXIT_INT:
POP
BOXCH    A, ACCBUF      ; Restore ACC value.

RETI     ; Exit interrupt vector
    
```

When the INT0 trigger occurs, the P00IRQ will be set to "1" no matter the P00IEN is enable or disable. If the P00IEN = 1 and the trigger event P00IRQ is also set to be "1". As the result, the system will execute the interrupt vector (ORG 8). If the P00IEN = 0 and the trigger event P00IRQ is still set to be "1". Moreover, the system won't execute interrupt vector even when the P00IRQ is set to be "1". Users need to be cautious with the operation under multi-interrupt situation.

INT1 (P0.1) INTERRUPT OPERATION

The INT1 is triggered by falling edge. When the INT1 trigger occurs, the P01IRQ will be set to "1" however the P01IEN is enable or disable. If the P01IEN = 1, the trigger event will make the P01IRQ to be "1" and the system enter interrupt vector. If the P01IEN = 0, the trigger event will make the P01IRQ to be "1" but the system will not enter interrupt vector. Users need to care for the operation under multi-interrupt situation.

➤ Example: INT1 interrupt request setup.

```

BOBSET      FP01IEN      ; Enable INT1 interrupt service
BOBCLR      FP01IRQ     ; Clear INT1 interrupt request flag
BOBSET      FGIE        ; Enable GIE

```

➤ Example: INT1 interrupt service routine.

```

ORG          8           ; Interrupt vector
JMP          INT_SERVICE
INT_SERVICE:

BOXCH       A, ACCBUF    ; Store ACC value.
PUSH

BOBTS1      FP01IRQ     ; Check P01IRQ
JMP         EXIT_INT    ; P01IRQ = 0, exit interrupt vector

BOBCLR      FP01IRQ     ; Reset P01IRQ
.           .           ; INT1 interrupt service routine
.           .

EXIT_INT:

POP         ; Pop
BOXCH       A, ACCBUF    ; Restore ACC value.

RETI        ; Exit interrupt vector

```

T0 INTERRUPT OPERATION

When the T0C counter occurs overflow, the T0IRQ will be set to "1" however the T0IEN is enable or disable. If the T0IEN = 1, the trigger event will make the T0IRQ to be "1" and the system enter interrupt vector. If the T0IEN = 0, the trigger event will make the T0IRQ to be "1" but the system will not enter interrupt vector. Users need to care for the operation under multi-interrupt situation.

⇒ Example: T0 interrupt request setup.

```

BOBCLR    FT0IEN    ; Disable T0 interrupt service
BOBCLR    FT0ENB    ; Disable T0 timer
MOV       A, #20H   ;
BOMOV     T0M, A    ; Set T0 clock = FCPU / 64
MOV       A, #74H   ; Set T0C initial value = 74H
BOMOV     T0C, A    ; Set T0 interval = 10 ms

BOBSET    FT0IEN    ; Enable T0 interrupt service
BOBCLR    FT0IRQ    ; Clear T0 interrupt request flag
BOBSET    FT0ENB    ; Enable T0 timer

BOBSET    FGIE      ; Enable GIE

```

⇒ Example: T0 interrupt service routine.

```

ORG       8          ; Interrupt vector
JMP       INT_SERVICE
INT_SERVICE:

BOXCH     A, ACCBUF  ; Store ACC value.
PUSH     ; Push

BOBTS1    FT0IRQ    ; Check T0IRQ
JMP       EXIT_INT  ; T0IRQ = 0, exit interrupt vector

BOBCLR    FT0IRQ    ; Reset T0IRQ
MOV       A, #74H   ;
BOMOV     T0C, A    ; Reset T0C.
.         .         ; T0 interrupt service routine
.         .

EXIT_INT:
POP       ; Pop
BOXCH     A, ACCBUF ; Restore ACC value.

RETI     ; Exit interrupt vector

```

TC0 INTERRUPT OPERATION

When the TC0C counter occurs overflow, the TC0IRQ will be set to "1" however the TC0IEN is enable or disable. If the TC0IEN = 1, the trigger event will make the TC0IRQ to be "1" and the system enter interrupt vector. If the TC0IEN = 0, the trigger event will make the TC0IRQ to be "1" but the system will not enter interrupt vector. Users need to care for the operation under multi-interrupt situation.

⇒ Example: TC0 interrupt request setup.

```

BOBCLR    FTC0IEN    ; Disable TC0 interrupt service
BOBCLR    FTC0ENB    ; Disable TC0 timer
MOV       A, #20H    ;
BOMOV     TC0M, A    ; Set TC0 clock = FCPU / 64
MOV       A, #74H    ; Set TC0C initial value = 74H
BOMOV     TC0C, A    ; Set TC0 interval = 10 ms

BOBSET    FTC0IEN    ; Enable TC0 interrupt service
BOBCLR    FTC0IRQ    ; Clear TC0 interrupt request flag
BOBSET    FTC0ENB    ; Enable TC0 timer

BOBSET    FGIE       ; Enable GIE

```

⇒ Example: TC0 interrupt service routine.

```

ORG       8          ; Interrupt vector
JMP      INT_SERVICE
INT_SERVICE:

BOXCH    A, ACCBUF   ; Store ACC value.
PUSH

BOBTS1   FTC0IRQ    ; Check TC0IRQ
JMP      EXIT_INT   ; TC0IRQ = 0, exit interrupt vector

BOBCLR   FTC0IRQ    ; Reset TC0IRQ
MOV      A, #74H    ;
BOMOV    TC0C, A    ; Reset TC0C.
.        .          ; TC0 interrupt service routine
.        .

EXIT_INT:

POP      ; Pop
BOXCH    A, ACCBUF   ; Restore ACC value.

RETI    ; Exit interrupt vector

```

TC1 INTERRUPT OPERATION

When the TC1C counter occurs overflow, the TC1IRQ will be set to "1" however the TC1IEN is enable or disable. If the TC1IEN = 1, the trigger event will make the TC1IRQ to be "1" and the system enter interrupt vector. If the TC1IEN = 0, the trigger event will make the TC1IRQ to be "1" but the system will not enter interrupt vector. Users need to care for the operation under multi-interrupt situation.

⇒ Example: TC1 interrupt request setup.

```

B0BCLR    FTC1IEN    ; Disable TC1 interrupt service
B0BCLR    FT C1ENB  ; Disable TC1 timer
MOV       A, #20H   ;
B0MOV     TC1M, A    ; Set TC1 clock = FCPU / 64
MOV       A, #74H   ; Set TC1C initial value = 74H
B0MOV     TC1C, A    ; Set TC1 interval = 10 ms

B0BSET    FTC1IEN    ; Enable TC1 interrupt service
B0BCLR    FTC1IRQ    ; Clear TC1 interrupt request flag
B0BSET    FTC1ENB    ; Enable TC1 timer

B0BSET    FGIE       ; Enable GIE

```

⇒ Example: TC1 interrupt service routine.

```

ORG       8          ; Interrupt vector
JMP      INT_SERVICE
INT_SERVICE:

B0XCH    A, ACCBUF   ; Store ACC value.
PUSH

B0BTS1   FTC1IRQ    ; Check TC1IRQ
JMP      EXIT_INT   ; TC1IRQ = 0, exit interrupt vector

B0BCLR   FTC1IRQ    ; Reset TC1IRQ
MOV      A, #74H    ;
B0MOV    TC1C, A    ; Reset TC1C.
.        .          ; TC1 interrupt service routine
.        .

EXIT_INT:

POP      ; Pop
B0XCH    A, ACCBUF   ; Restore ACC value.

RETI    ; Exit interrupt vector

```

SIO INTERRUPT OPERATION

When the SIO finished transmitting, the SIOIRQ will be set to "1" however the SIOIEN is enable or disable. If the SIOIEN = 1, the trigger event will make the SIOIRQ to be "1" and the system enter interrupt vector. If the SIOIEN = 0, the trigger event will make the SIOIRQ to be "1" but the system will not enter interrupt vector. Users need to care for the operation under multi-interrupt situation.

➤ Example: SIO interrupt request setup.

```

BOBSET      FSIOIEN      ; Enable SIO interrupt service
BOBCLR      FSIOIRQ      ; Clear SIO interrupt request flag
BOBSET      FGIE         ; Enable GIE

```

➤ Example: SIO interrupt service routine.

```

ORG          8              ; Interrupt vector
JMP          INT_SERVICE
INT_SERVICE:

BOXCH       A, ACCBUF      ; Store ACC value.
PUSH

B0BTS1     FSIOIRQ        ; Check SIOIRQ
JMP        EXIT_INT       ; SIOIRQ = 0, exit interrupt vector

B0BCLR     FSIOIRQ        ; Reset SIOIRQ
.          .              ; SIO interrupt service routine
.          .

EXIT_INT:

POP
BOXCH     A, ACCBUF      ; Restore ACC value.

RETI      ; Exit interrupt vector

```

MULTI-INTERRUPT OPERATION

In most conditions, the software designer uses more than one interrupt request. Processing multi-interrupt request needs to set the priority of these interrupt requests. The IRQ flags of the 6 interrupts are controlled by the interrupt event occurring. Set IRQ flag to 1 doesn't mean the system to execute the interrupt vector. The IRQ flags can be triggered by the events without interrupt enable. Just only any the event occurs and the IRQ will be logic "1". The IRQ and its trigger event relationship is as the below table.

<i>Interrupt Name</i>	<i>Trigger Event Description</i>
P00IRQ	P0.0 trigger controlled by PEDGE
P01IRQ	P0.1 trigger. Falling edge.
T0IRQ	T0C overflow.
TC0IRQ	TC0C overflow.
TC1IRQ	TC1C overflow.
SIOIRQ	End of SIO transmitter operating.

There are two things need to do for multi-interrupt. One is to make a good priority for these interrupt requests. Two is using IEN and IRQ flags to decide executing interrupt service routine or not. Users have to check interrupt control bit and interrupt request flag in interrupt vector. There is a simple routine as following.

⇒ **Example: How does users check the interrupt request in multi-interrupt situation?**

```

ORG            8            ; Interrupt vector

INTP00CHK:    BOXCH        A, ACCBUF    ; Store ACC value.
              PUSH                ; Push
              ; Check INT0 interrupt request
              B0BTS1        FP00IEN    ; Check P00IEN
              JMP            INTP01CHK  ; Jump check to next interrupt
              B0BTS0        FP00IRQ    ; Check P00IRQ
              JMP            INTP00     ; Jump to INT0 interrupt service routine
INTP01CHK:    B0BTS1        FP01IEN    ; Check INT1 interrupt request
              JMP            INTP02CHK  ; Check P01IEN
              B0BTS0        FP01IRQ    ; Jump check to next interrupt
              JMP            INTP01     ; Check P01IRQ
INTT0CHK:     B0BTS1        FT0IEN     ; Jump to INT1 interrupt service routine
              JMP            INTTC0CHK  ; Check INT1 interrupt request
              B0BTS0        FT0IRQ     ; Check T0 interrupt request
              JMP            INTT0      ; Check T0IEN
INTTC0CHK:    B0BTS1        FT0IEN     ; Jump check to next interrupt
              JMP            INTTC0CHK  ; Check T0IRQ
              B0BTS0        FT0IRQ     ; Check T0 interrupt service routine
              JMP            INTT0      ; Check TC0 interrupt request
INTTC0CHK:    B0BTS1        FTC0IEN    ; Check TC0IEN
              JMP            INTTC1CHK  ; Jump check to next interrupt
              B0BTS0        FTC0IRQ    ; Check TC0IRQ
              JMP            INTTC0     ; Jump to TC0 interrupt service routine
INTTC1CHK:    B0BTS1        FTC1IEN    ; Check TC1 interrupt request
              JMP            INTSIOCHK  ; Check TC1IEN
              B0BTS0        FTC1IRQ    ; Jump check to next interrupt
              JMP            INTTC1     ; Check TC1IRQ
INTSIOCHK:    B0BTS1        FSIOIEN    ; Jump to TC1 interrupt service routine
              JMP            INT_EXIT   ; Check SIO interrupt request
              B0BTS0        FSIOIRQ    ; Check SIOIEN
              JMP            INTSIO     ; Check SIOIRQ
INT_EXIT:     B0BTS1        FSIOIEN    ; Jump to SIO interrupt service routine
              JMP            INT_EXIT   ; Check SIOIEN
              B0BTS0        FSIOIRQ    ; Check SIOIRQ
              JMP            INTSIO     ; Jump to SIO interrupt service routine

              POP                ; Pop
              BOXCH        A, ACCBUF    ; Restore ACC value.

              RETI                ; Exit interrupt vector

```

10 SERIAL INPUT/OUTPUT TRANSCEIVER (SIO)

OVERVIEW

The SIO (serial input/output) transceiver allows high-speed synchronous data transfer between this chip and peripheral devices or between several MCU. These peripheral devices may be Serial EEPROMs, shift registers, display drivers, etc. The SN8P2700A SIO features include the following:

- Full-duplex, 3-wire synchronous data transfer
- TX/RX or TX Only mode
- Master (SCK is clock output) or Slave (SCK is clock input) operation
- LSB first data transfer
- Two programmable bit rates (Only in master mode)
- End-of-Transfer interrupt

The SIOM register can control SIO operating function, such as: transmit/receive, clock rate, transfer edge and starting this circuit. This SIO circuit will transmit or receive 8-bit data automatically by setting SENB and START bits in SIOM register. The SIOB is an 8-bit buffer, which is designed to store transfer data. SIOC and SIOR are designed to generate SIO's clock source with auto-reload function. The 3-bit I/O counter can monitor the operation of SIO and announce an interrupt request after transmitting/receiving 8-bit data. After transferring 8-bit data, this circuit will be disabled automatically and re-transfer data by programming SIOM register.

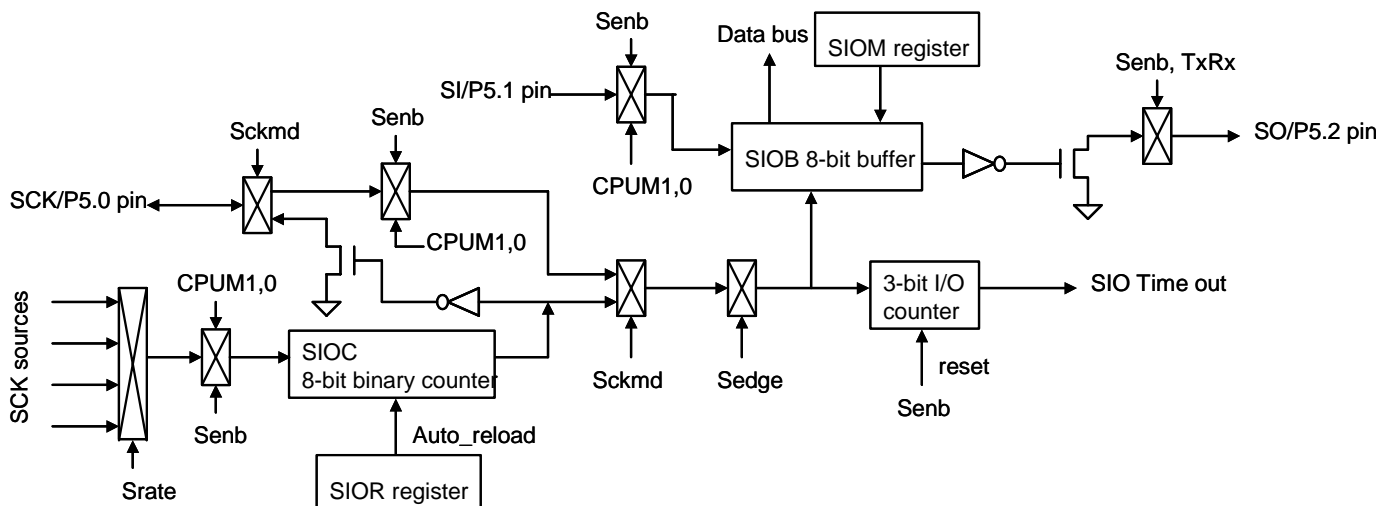

Figure 10-1. SIO Interface Circuit Diagram

Following figure shows a typical transfer between two micro-controllers. Process 1 sends SCK for initial the data transfer. When both processors must work in the same clock edge, both controllers would send and receive data at the same time.

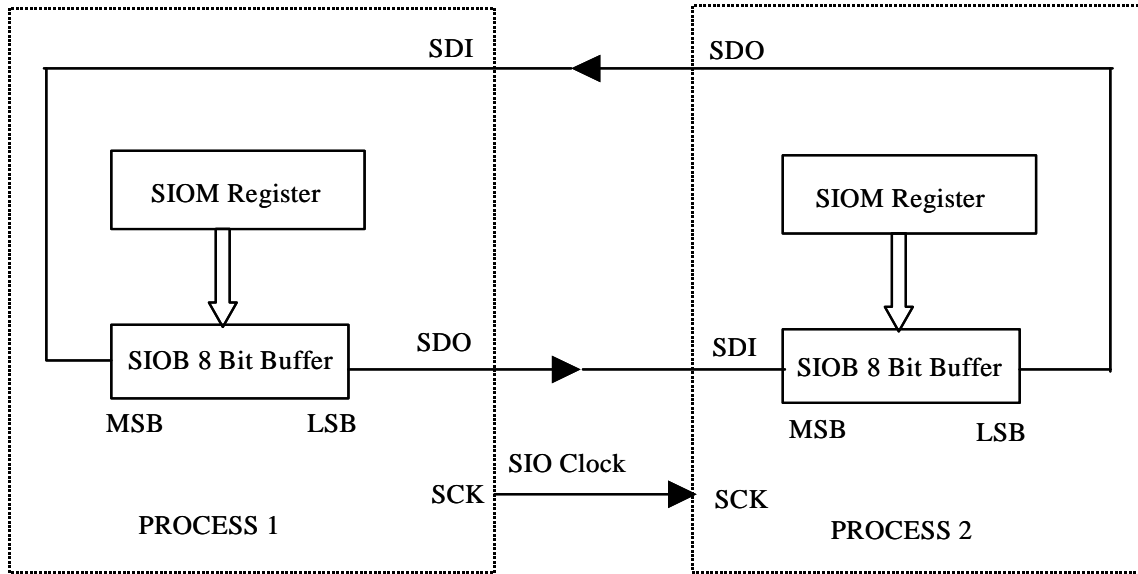

Figure 10-2. SIO Data Transfer Diagram

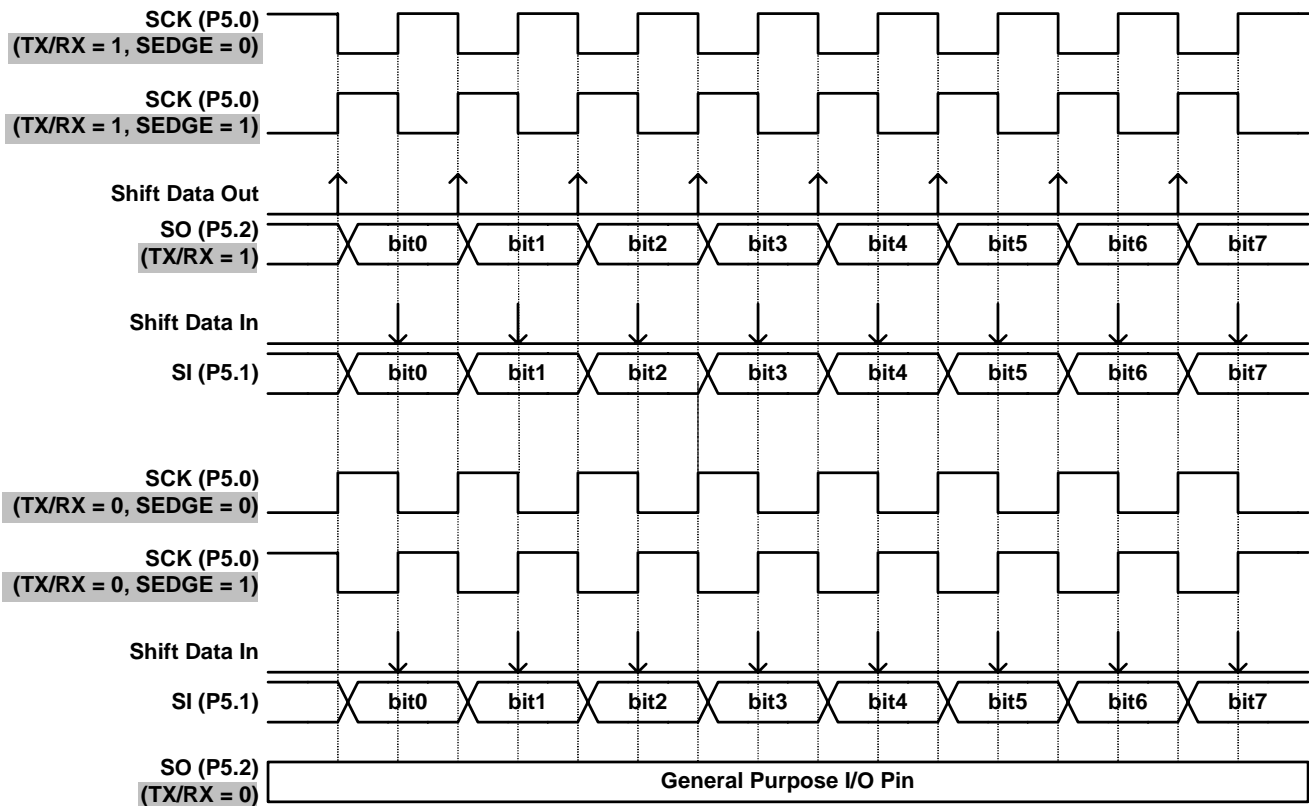

Figure 10-3. SIO Data Timing Chart

SIOM MODE REGISTER

SIOM initial value = 0000 x000

0B4H	Bit 7	Bit 6	Bit 5	Bit 4	Bit 3	Bit 2	Bit 1	Bit 0
SIOM	SENB	START	SRATE1	SRATE0	SIG	SCKMD	SEGE	TXRX
	R/W	R/W	R/W	R/W	R/W	R/W	R/W	R/W

- SENB:** SIO function control bit.
0 = Disable (P5.0~P5.2 is general purpose port)
1 = Enable (P5.0~P5.2 is SIO pins).
- START:** SIO progress control bit.
0 = End of transmit
1 = Progressing.
- SRATE [1:0] :** SIO transmit rate select bit.
00 = F_{CPU} , 01 = $F_{CPU}/32$, 10 = $F_{CPU}/16$, 11 = $F_{CPU}/8$.
(Note: These 2-bits are workless when SCKMD=1)
- SIG:** Start SIO receiver function automatically.
0 = Disable
1 = Enable.
- SCKMD:** SIO clock mode select bit.
0 = Internal
1 = External mode.
- SEGE:** SIO transmit clock edge select bit.
0 = Falling edge
1 = Raising edge
- TXRX:** SIO transfer direction select bit.
0 = Receive only
1 = Transmit/Receive full duplex.

- **Note 1:** If SCKMD=1 for external clock, the SIO is in SLAVE mode.
If SCKMD=0 for internal clock, the SIO is in MASTER mode.
- **Note 2:** Don't set SENB and START bits in the same time. That makes the SIO function error.

Because SIO function is shared with Port5 for P5.0 as SCK, P5.1 as SI and P5.2 as SO
The following table showed the Port5[2:0] I/O mode behavior and setting when SIO function enable and disable

SENB=1 (SIO Function Enable)		
P5.0/SCK	(SCKMD=1) SIO source = External clock	P5.0 will change to Input mode automatically, no matter what P5M setting
	(SCKMD=0) SIO source = Internal clock	P5.0 will change to Output mode automatically, no matter what P5M setting
P5.1/SI	P5.1 must be set as Input mode in P5M, or the SIO function will be abnormal	
P5.2/SO	(TXRX=1) SIO = Transmitter/Receiver	P5.2 will change to Output mode automatically, no matter what P5M setting
	(TXRX=0) SIO = Receiver only	P5.2 will change to Input mode automatically, no matter what P5M setting
SENB=0 (SIO Function Disable)		
P5.0/P5.1/P5.2	Port5 [2:0] I/O mode are fully controlled by P5M when SIO function Disable	

SI0B DATA BUFFER

SI0B initial value = 0000 0000

0B6H	Bit 7	Bit 6	Bit 5	Bit 4	Bit 3	Bit 2	Bit 1	Bit 0
SI0B	SI0B7	SI0B6	SI0B5	SI0B4	SI0B3	SI0B2	SI0B1	SI0B0
	R/W	R/W	R/W	R/W	R/W	R/W	R/W	R/W

SI0B is the SIO data buffer register. It stores serial I/O transmit and receive data.

SI0R REGISTER DESCRIPTION

SI0R initial value = 0000 0000

0B5H	Bit 7	Bit 6	Bit 5	Bit 4	Bit 3	Bit 2	Bit 1	Bit 0
SI0R	SI0R7	SI0R6	SI0R5	SI0R4	SI0R3	SI0R2	SI0R1	SI0R0
	W	W	W	W	W	W	W	W

The SI0R is designed for the SIO counter to reload the counted value when end of counting. It is like a post-scalar of SIO clock source and let SIO has more flexible to setting SCK range. Users can set the SI0R value to setup SIO transfer time. To setup SI0R value equation to desire transfer time is as following.

$$\text{SCK frequency} = \text{SIO rate} / (256 - \text{SI0R})$$

$$\text{SI0R} = 256 - (1 / (\text{SCK frequency}) * \text{SIO rate})$$

⇒ **Example: Setup the SIO clock to be 5KHz. F_{OSC} = 3.58MHz. SIO rate = F_{CPU} = F_{OSC} /4.**

$$\begin{aligned} \text{SI0R} &= 256 - (1/(5\text{KHz}) * 3.58\text{MHz}/4) \\ &= 256 - (0.0002*895000) \\ &= 256 - 179 \\ &= 77 \end{aligned}$$

SIO MASTER OPERATING DESCRIPTION

Under master-transmitter situation, the SCK has two directions as following.

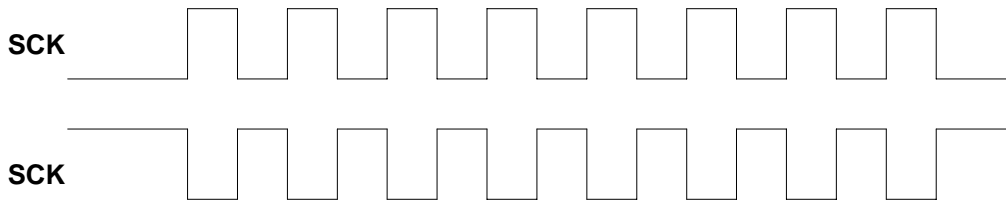

Figure 10-4. The Two SCK Directions of SIO Master Operation

RISING EDGE TRANSMITTER/RECEIVER MODE

➔ **Example: Master TX/RX rising edge**

```

MOV      A, TXDATA      ; Load transmitted data into SIOB register.
B0MOV   SIOB, A
MOV     A, #0FFH       ; Set SIO clock with auto-reload function.
B0MOV   SIOR, A
MOV     A, #10000011B  ; Setup SIOM and enable SIO function. Rising edge.
B0MOV   SIOM, A
B0BSET  FSTART        ; Start transfer and receiving SIO data.
CHK_END:
B0BTS0  FSTART        ; Wait the end of SIO operation.
JMP     CHK_END
B0MOV   A, SIOB       ; Save SIOB data into RXDATA buffer.
MOV     RXDATA, A
    
```

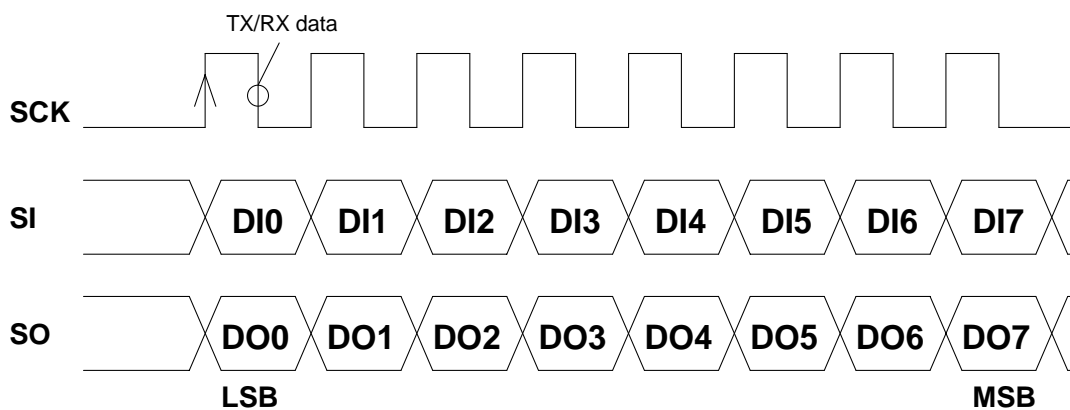

Figure 10-5. The Rising Edge Timing Diagram of Master Transmit and Receive Operation

FALLING EDGE TRANSMITTER/RECEIVER MODE

➔ Example: Master Tx/Rx falling edge

```

MOV          A,TXDATA          ; Load transmitted data into SIOB register.
B0MOV       SIOB,A
MOV         A,#0FFH           ; Set SIO clock with auto-reload function.
B0MOV       SIOR,A
MOV         A,#10000001B      ; Setup SIOM and enable SIO function. Falling edge.
B0MOV       SIOM,A
B0BSET      FSTART           ; Start transfer and receiving SIO data.

CHK_END:
B0BTS0      FSTART           ; Wait the end of SIO operation.
JMP         CHK_END
B0MOV       A,SIOB           ; Save SIOB data into RXDATA buffer.
MOV         RXDATA,A

```

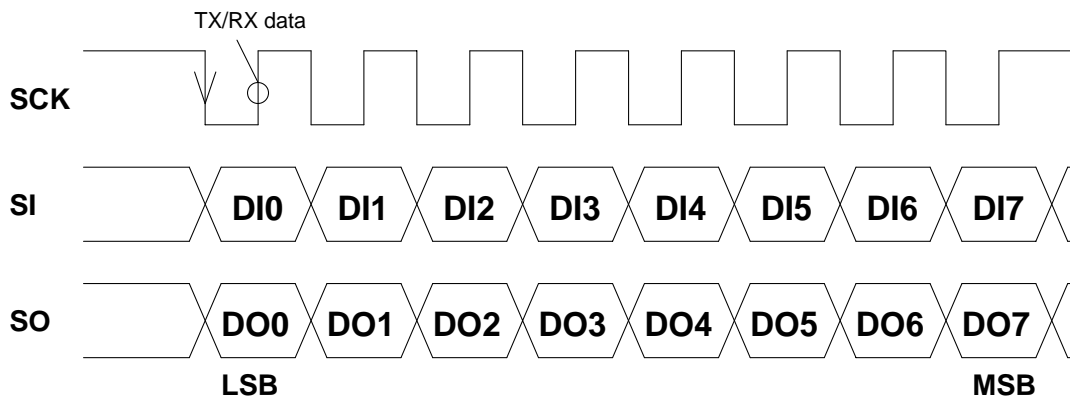

Figure 10-6. The Falling Edge Timing Diagram of Master Transmit and Receive Operation

RISING EDGE RECEIVER MODE

➔ Example: Master Rx rising edge

```

MOV          A,#0FFH           ; Set SIO clock with auto-reload function.
B0MOV       SIOR,A
MOV          A,#10000010B      ; Setup SIOM and enable SIO function. Rising edge.
B0MOV       SIOM,A
B0BSET      FSTART            ; Start receiving SIO data.
CHK_END:
B0BTS0     FSTART            ; Wait the end of SIO operation.
JMP        CHK_END
B0MOV      A,SIOB            ; Save SIOB data into RXDATA buffer.
MOV        RXDATA,A

```

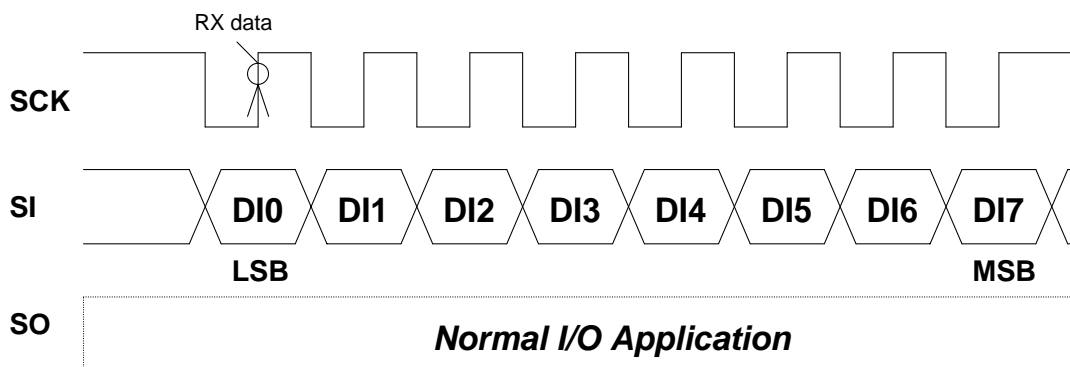

Figure 10-7. The Rising Edge Timing Diagram of Master Receiving Operation

FALLING EDGE RECEIVER MODE

➔ Example: Master Rx falling edge

```

MOV          A,#0FFH           ; Set SIO clock with auto-reload function.
B0MOV       SIOR,A
MOV          A,#10000000B      ; Setup SIOM and enable SIO function. Falling edge.
B0MOV       SIOM,A
B0BSET      FSTART            ; Start receiving SIO data.
CHK_END:
B0BTS0     FSTART             ; Wait the end of SIO operation.
JMP        CHK_END
B0MOV      A,SIOB              ; Save SIOB data into RXDATA buffer.
MOV        RXDATA,A

```

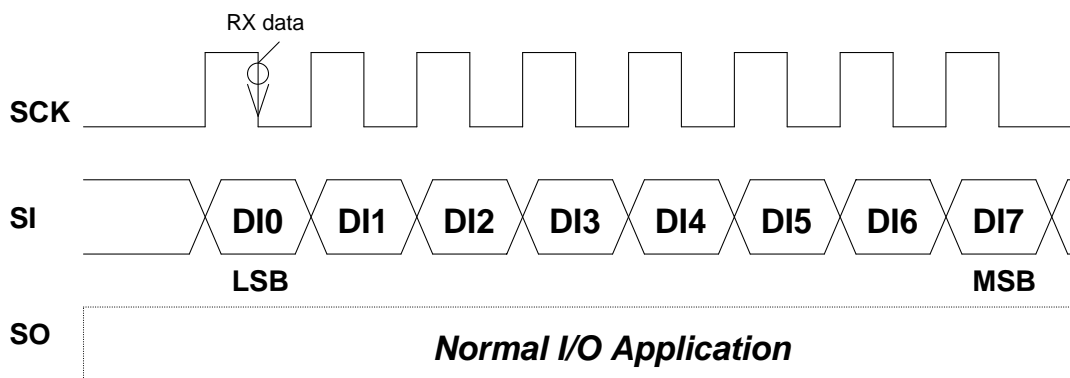

Figure 10-8. The Falling Edge Timing Diagram of Master Receiving Operation

SIO SLAVE OPERATING DESCRIPTION

Under slave-receiver situation, the SCK has four phases as following.

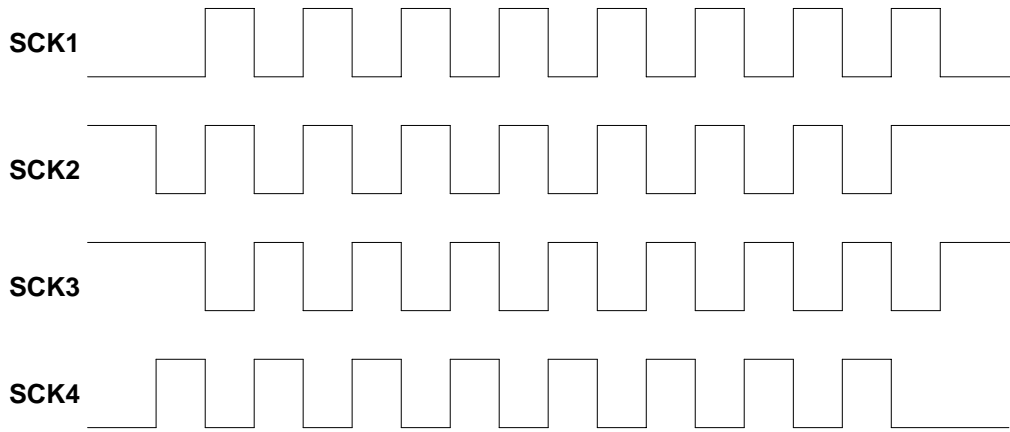

Figure 10-9. The Four Phases of SCK clock when SIO is Slave Operation.

RISING EDGE TRANSMITTER/RECEIVER MODE

➔ **Example: Slave Tx/Rx rising edge**

```

MOV          A, TXDATA          ; Load transfer data into SIOB register.
B0MOV       SIOB, A
MOV         A, # 10000111B      ; Setup SIOM and enable SIO function. Rising edge.
B0MOV       SIOM, A
BOBSET      FSTART             ; Start transfer and receiving SIO data.
CHK_END:
BOBTS0     FSTART             ; Wait the end of SIO operation.
JMP        CHK_END
B0MOV       A, SIOB            ; Save SIOB data into RXDATA buffer.
MOV        RXDATA, A
    
```

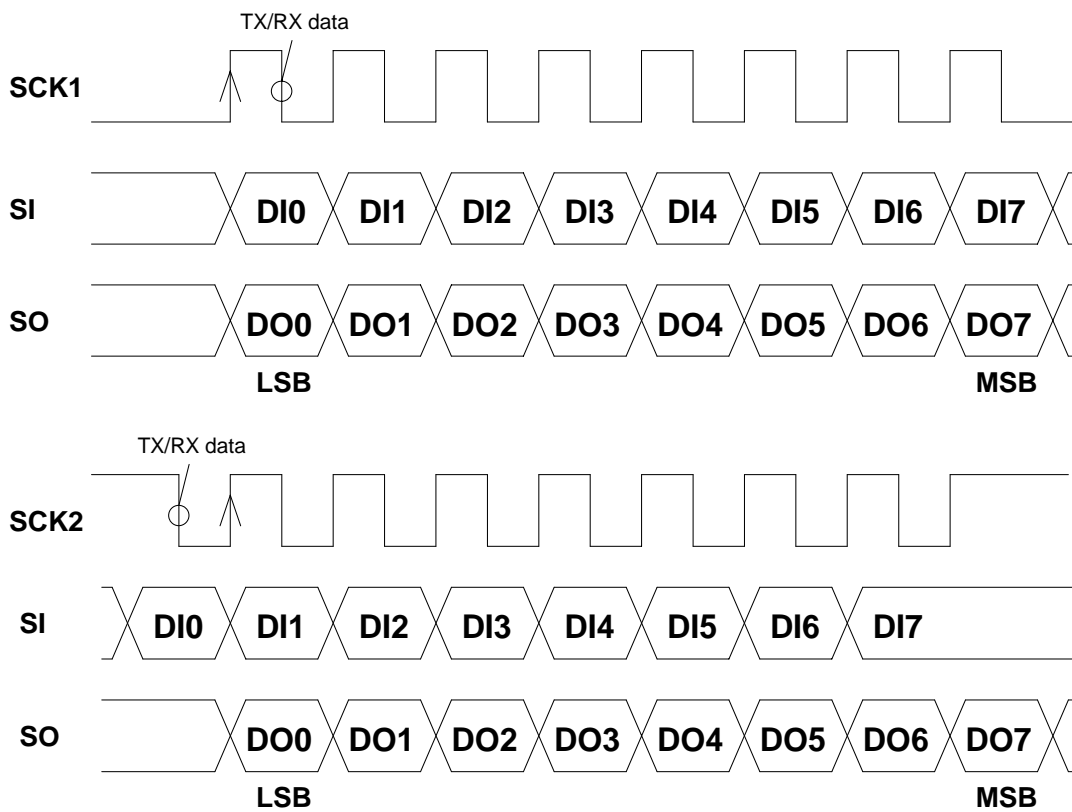

Figure 10-10. The Rising Edge Timing Diagram of Slave Transfer and Receiving Operation

FALLING EDGE TRANSMITTER/RECEIVER MODE

➔ **Example: Slave Tx/Rx falling edge**

```

MOV          A,TXDATA          ; Load transfer data into SIOB register.
B0MOV       SIOB,A
MOV         A,# 10000101B      ; Setup SIOM and enable SIO function. Falling edge.
B0MOV       SIOM,A
BOBSET      FSTART            ; Start transfer and receiving SIO data.
CHK_END:
BOBTS0     FSTART            ; Wait the end of SIO operation.
JMP        CHK_END
B0MOV      A,SIOB              ; Save SIOB data into RXDATA buffer.
MOV        RXDATA,A
    
```

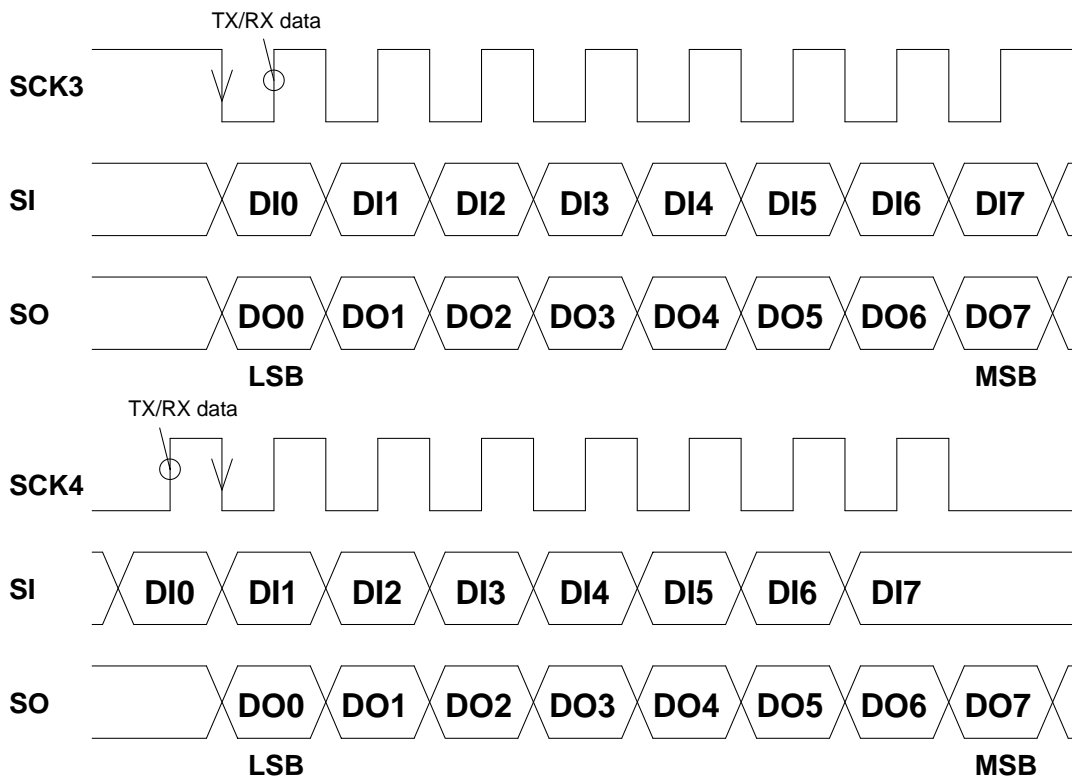

Figure 10-11. The Falling Edge Timing Diagram of Slave Transfer and Receiving Operation

RISING EDGE RECEIVER MODE

➔ **Example: Slave Rx rising edge**

```

MOV          A,# 10000110B      ; Setup SIOM and enable SIO function. Rising edge.
B0MOV       SIOM,A
B0BSET      FSTART             ; Start receiving SIO data.
CHK_END:
B0BTS0     FSTART             ; Wait the end of SIO operation.
JMP        CHK_END
B0MOV       A,SIOB             ; Save SIOB data into RXDATA buffer.
MOV        RXDATA,A
    
```

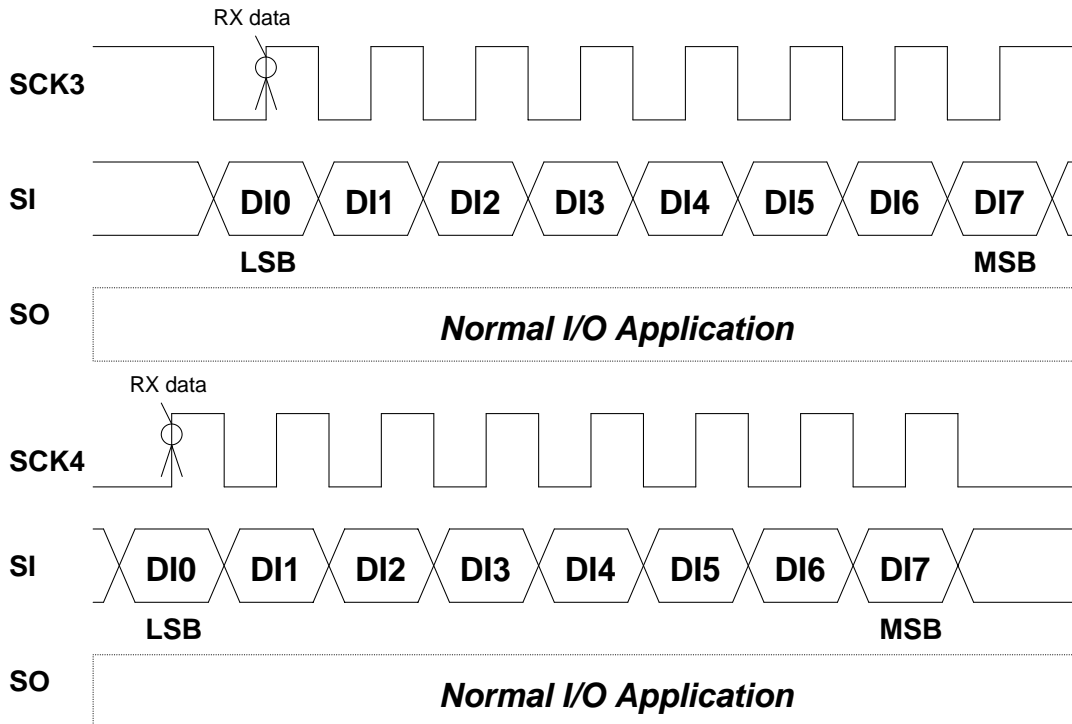

Figure 10-12. The Rising Edge Timing Diagram of Slave Receiving Operation

FALLING EDGE RECEIVER MODE

➔ Example: Slave Rx falling edge

```

MOV          A,# 10000100B      ; Setup SIOM and enable SIO function. Falling edge.
B0MOV       SIOM,A
B0BSET      FSTART              ; Start receiving SIO data.
CHK_END:
B0BTS0     FSTART              ; Wait the end of SIO operation.
JMP        CHK_END
B0MOV       A,SIOB              ; Save SIOB data into RXDATA buffer.
MOV        RXDATA,A

```

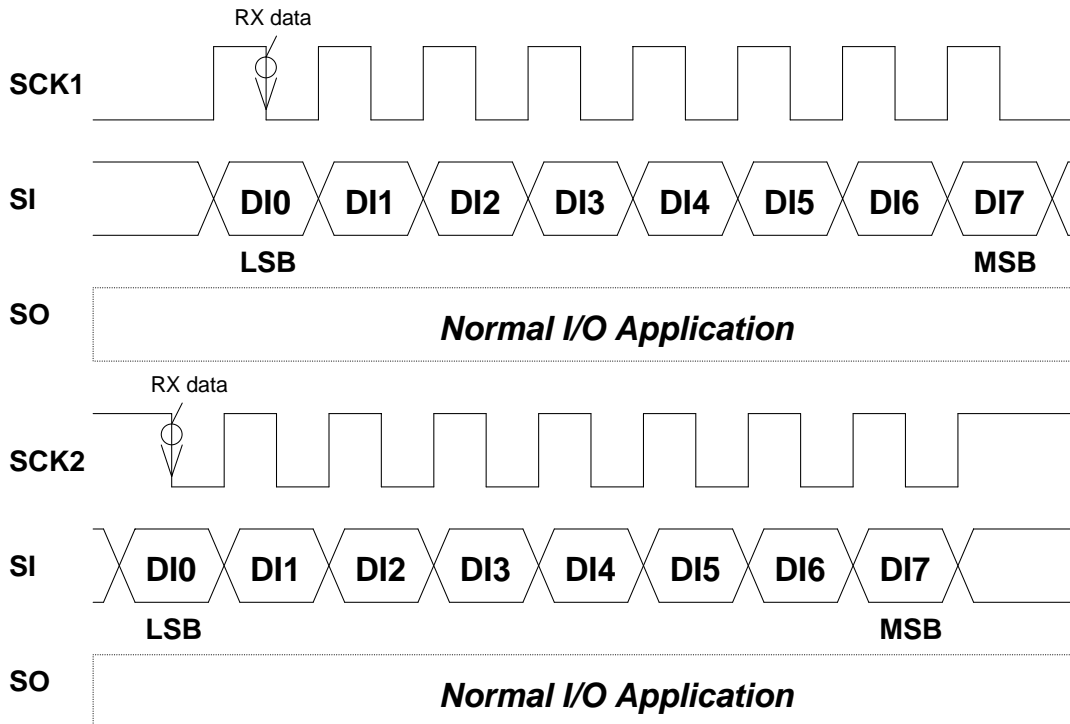

Figure 10-13. The Falling Edge Timing Diagram of Slave Receiving Operation

SIO INTERRUPT OPERATION DESCRIPTION

The SIO provides an interrupt function. Users can process SIO data after the SIO interrupt request occurring. There is an example for the application as following.

➔ Example: SIO interrupt demo routine.

Main:

```

MOV      A,# 10000100B      ; Setup SIOM and enable SIO function. Falling edge.
B0MOV    SIOM,A
B0BSET   FSTART            ; Start transfer SIO data.
.
.
JMP      MAIN

```

```

ORG      8                  ; Interrupt vector

```

```

B0XCH    A, ACCBUF
PUSH

```

```

B0BTS1   FSIOIRQ
JMP      INT_EXIT
B0MOV    A,SIOB            ; Save SIOB data into RXDATA buffer.
MOV      RXDATA,A
B0BCLR   FSIOIRQ          ; Clear SIO interrupt request flag.

```

INT_EXIT:

```

POP
B0XCH    A, ACCBUF

```

11 I/O PORT

OVERVIEW

The SN8P1900 provides up to four ports for users' application, consisting of two input only ports (P0, P2), two I/O ports (P1, P5). The direction of I/O port is selected by P_NM register.

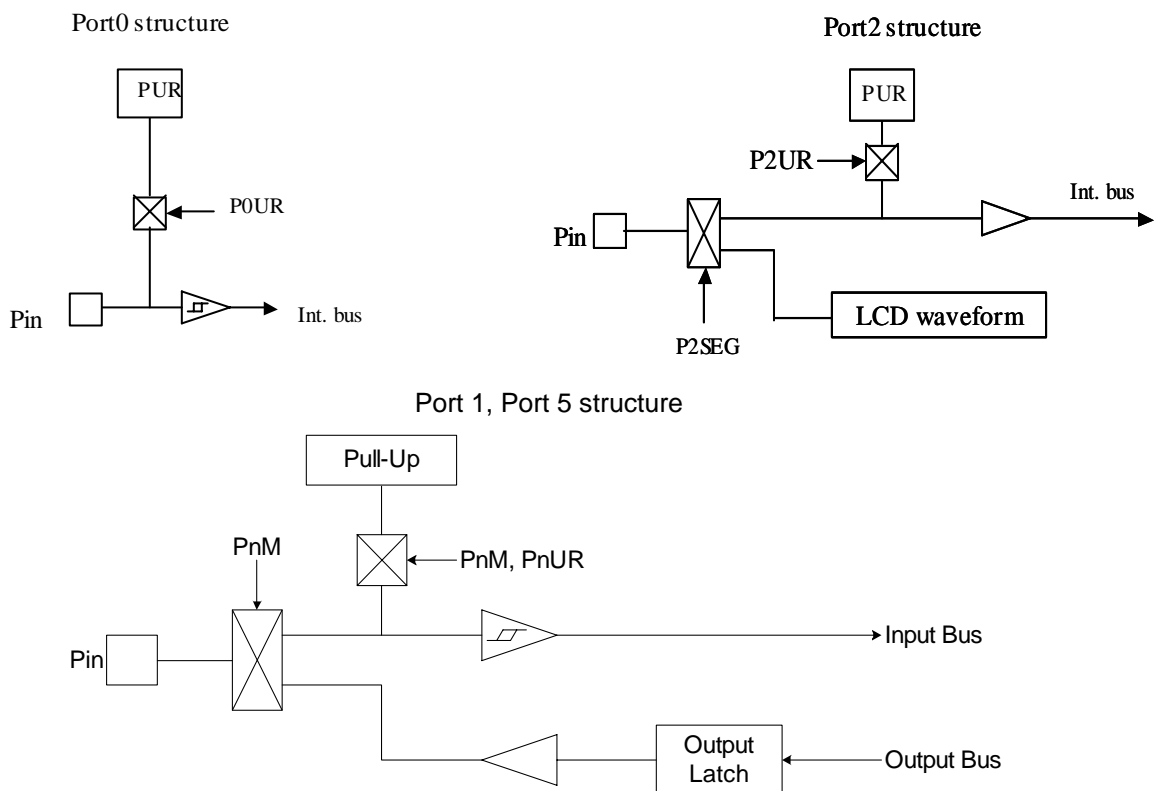

Figure 11-1. The I/O Port Block Diagram

➤ **Note :** All of the latch output circuits are push-pull structures.

I/O PORT FUNCTION TABLE

Port/Pin	I/O	Function Description	Remark
P0.0~P0.1	I	General-purpose input function	
		External interrupt (INT0~INT1)	See <P00G1,P00G0>
		Wakeup for power down mode	See <P00G1,P00G0>
P1.0~P1.4	I/O	General-purpose input/output function	
		Wakeup for power down mode	
P2.0~P2.7	I	General-purpose Input function	
		LCD segment	
P5.0	I/O	General-purpose input/output function	
		SIO clock pin.	
P5.1	I/O	General-purpose input/output function	
	I	SIO data input pin.	P5M.1 must be set "0"
P5.2	I/O	General-purpose input/output function	
	O	SIO data output pin.	P5M.1 must be set "1"
P5.3~P5.4	I/O	General-purpose input/output function	

Table 11-1. I/O Function Table

PULL-UP RESISTOR (P_NUR) REGISTER

P_NUR initial value = 0000 0000

	Bit 7	Bit 6	Bit 5	Bit 4	Bit 3	Bit 2	Bit 1	Bit 0
P_NUR	P _N 7R	P _N 6R	P _N 5R	P _N 4R	P _N 3R	P _N 2R	P _N 1R	P _N 0R
	R/W	R/W	R/W	R/W	R/W	R/W	R/W	R/W

P_NUR : The n expressed 0, 1, 2, 5.

P_N7R ~ P_N0R: Pull-up resistor control bit.

0 = Without pull up resistor

1 = With pull up resistor.

I/O PORT MODE

The port direction is decided by P_NM register. Port 0 is always input mode. Port 1 and Port 5 can select input or output direction.

P1M initial value = xx00 0000

0C1H	Bit 7	Bit 6	Bit 5	Bit 4	Bit 3	Bit 2	Bit 1	Bit 0
P1M	0	0	0	P14M	P13M	P12M	P11M	P10M
	-	-	-	R/W	R/W	R/W	R/W	R/W

P10M~P15M: P1.0~P1.5 I/O direction control bit. 0 = input mode, 1 = output mode.

P5M initial value = 0000 0000

0C5H	Bit 7	Bit 6	Bit 5	Bit 4	Bit 3	Bit 2	Bit 1	Bit 0
P5M	0	0	0	P54M	P53M	P52M	P51M	P50M
	-	-	-	R/W	R/W	R/W	R/W	R/W

P50M~P54M: P5.0~P5.4 I/O direction control bit. 0 = input mode, 1 = output mode.

The each bit of P_NM is set to "0", the I/O pin is input mode. The each bit of P_NM is set to "1", the I/O pin is output mode.

➤ **The P_NM registers are read/write bi-direction registers. Users can program them by bit control instructions (B0BSET, B0BCLR).**

⇒ **Example: I/O mode selection.**

```
CLR      P1M      ; Set all ports to be input mode.
CLR      P5M
```

```
MOV      A, #0FFH ; Set all ports to be output mode.
B0MOV    P1M, A
B0MOV    P5M, A
```

```
B0BCLR   P1M.1    ; Set P1.1 to be input mode.
```

```
B0BSET   P1M.1    ; Set P1.1 to be output mode.
```

THE PORT2 DISCRPTION

The port 2 is Input pins and shared with SEG24~SEG31 LCD driver pins. The port2 must work without LCD. To set the bit P2SEG = "1", the port 2 Input function will be enabled. Input data from port 2 is by P2 data register.

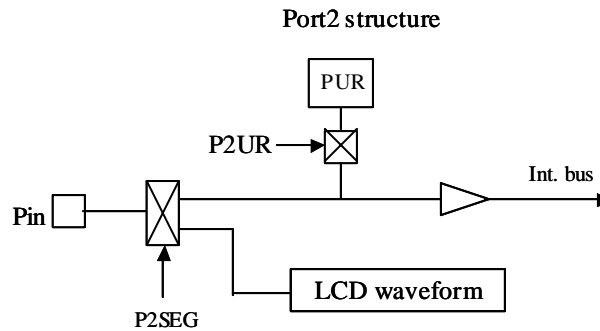

Figure 11-2. Port 2 Block Diagram

⇒ Example: Enable PORT 2 Input function.

Step1: Connect VLCD1 to VLCD

Step2: Set P2SEG=1

```
BOBSET      FP2SEG      ; Disable Pin 45 ~ 52 LCD driver.
```

Step3: Now the PORT 2 general input function is enable. User can input data by PORT 2.

```
B0MOV      A, P2      ; Input Port 2 value to BUF.
B0MOV      BUF, A
```

I/O PORT DATA REGISTER

P0 initial value = xxxx xxx0

0D0H	Bit 7	Bit 6	Bit 5	Bit 4	Bit 3	Bit 2	Bit 1	Bit 0
P0	-	-	-	-	-	-	P01	P00
	-	-	-	-	-	-	R	R

P1 initial value = xx00 0000

0D1H	Bit 7	Bit 6	Bit 5	Bit 4	Bit 3	Bit 2	Bit 1	Bit 0
P1	-	-	-	P14	P13	P12	P11	P10
	-	-	-	R/W	R/W	R/W	R/W	R/W

P2 initial value = 0000 0000

0D2H	Bit 7	Bit 6	Bit 5	Bit 4	Bit 3	Bit 2	Bit 1	Bit 0
P2	P27	P26	P25	P24	P23	P22	P21	P20
	R	R	R	R	R	R	R	R

P5 initial value = xxx0 0000

0D5H	Bit 7	Bit 6	Bit 5	Bit 4	Bit 3	Bit 2	Bit 1	Bit 0
P5	-	-	-	P54	P53	P52	P51	P50
	-	-	-	R/W	R/W	R/W	R/W	R/W

⇒ **Example: Read data from input port.**

```

B0MOV      A, P0           ; Read data from Port 0
B0MOV      A, P1           ; Read data from Port 1
B0MOV      A, P5           ; Read data from Port 5
    
```

⇒ **Example: Write data to output port.**

```

MOV        A, #55H        ; Write data 55H to Port 1 and Port 5
B0MOV      P1, A
B0MOV      P5, A
    
```

⇒ **Example: Write one bit data to output port.**

```

B0BSET     P1.3           ; Set P1.3 to be "1".
B0BCLR     P1.3           ; Set P1.3 and P5.1 to be "0".
B0BCLR     P5.1
    
```

⇒ **Example: Port bit test.**

```

B0BTS1     P0.0           ; Bit test 1 for P0.0
.
B0BTS0     P1.1           ; Bit test 0 for P1.1
    
```

12 LCD DRIVER

There are 4 common pins and 32 segment pins in the SN8P1900. The LCD scan timing is 1/4 duty and 1/2,1/3 bias structure to yield 128 dots LCD driver. Of these pins, eight segment pins are shared with Port 2 and P2/SEG functions can be selected by programming LCDM1 register.

LCDM1 REGISTER

LCDM1 register initial value = xx0x 00x1

0CBH	Bit 7	Bit 6	Bit 5	Bit 4	Bit 3	Bit 2	Bit 1	Bit 0
LCDM1	-	-	LCDBNK	-	LCDENB	BIAS	-	P2SEG
	-	-	R/W	-	R/W	R/W	-	R/W

P2SEG: Port2 control bit.
0 = Segment pins
1 = General purpose I/O pins.

BIAS: LCD bias control bit.
0 = 1/3 bias
1 = 1/2 bias

LCDENB: LCD driver enable control bit.
0 = Disable
1 = Enable.

LCDBNK: LCD blank control bit.
0 = Normal display
1 = All of the LCD dots off.

➤ **Note: Connect VLCD and VLCD1 to the same voltage.**

In following diagram, in order to get suitable contrast level of LCD panel, users can add external resistor to bias pin (V1, V2, V3) to adjust bias voltage and LCD drive current. Too much or less current makes the LCD to bring remnant images. In normal condition, the external bias resistor value is 100K ohm. Users can connect a resistor between VLCD and VDD to adjust the voltage level at VLCD pin or just connect VLCD to VDD directly.

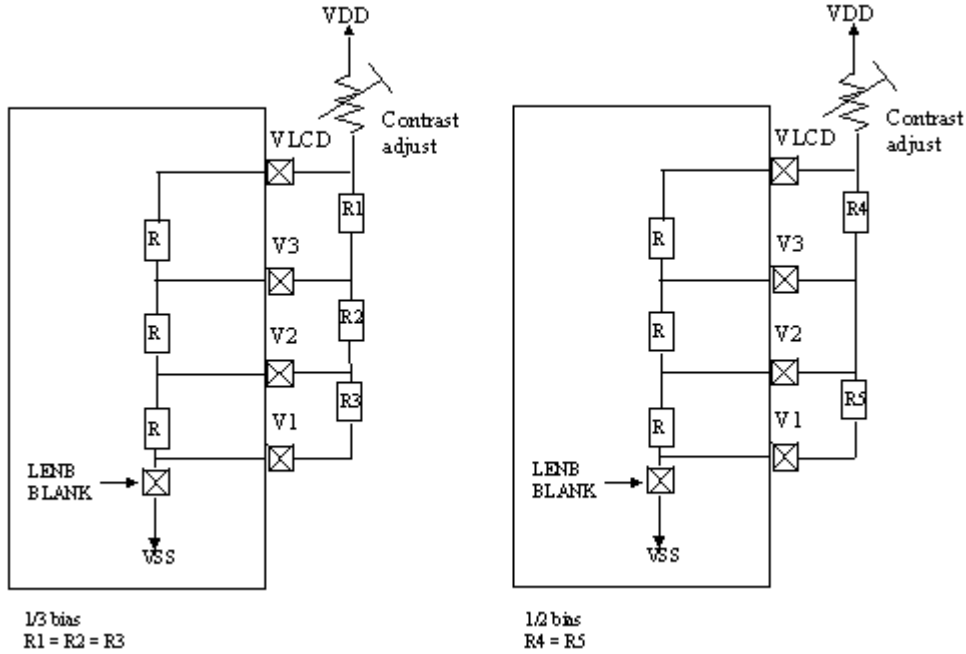

Figure 12-1. Example of circuit at each bias

LCD TIMING

$$F\text{-frame} = \text{External Low clock} / 512$$

Ex. External low clock is 32768Hz. The F-frame is $32768\text{Hz} / 512 = 64\text{Hz}$.

Note: The clock source of LCD driver is external low clock.

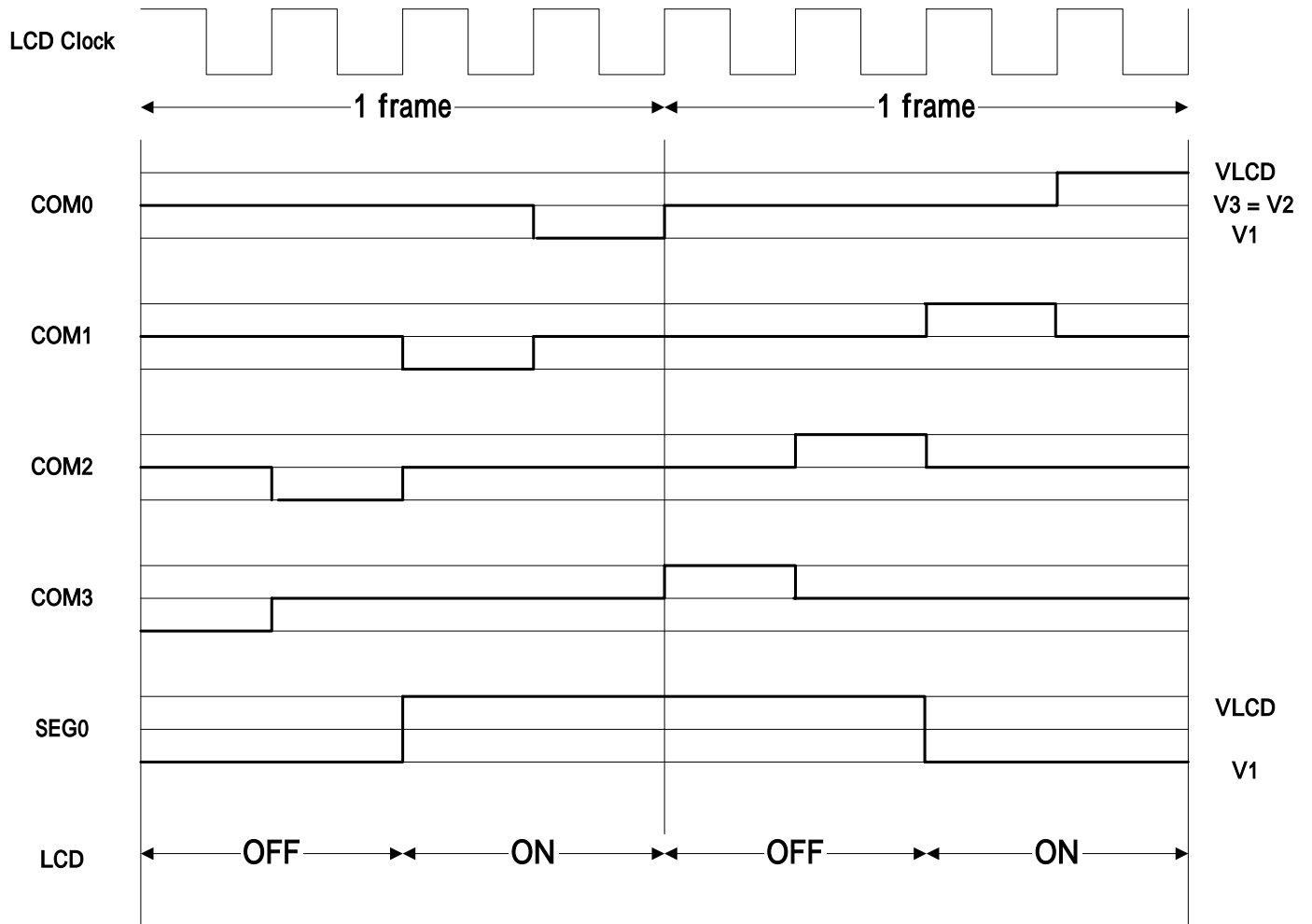

Figure 12-2. LCD Drive Waveform, 1/4 duty, 1/2 bias

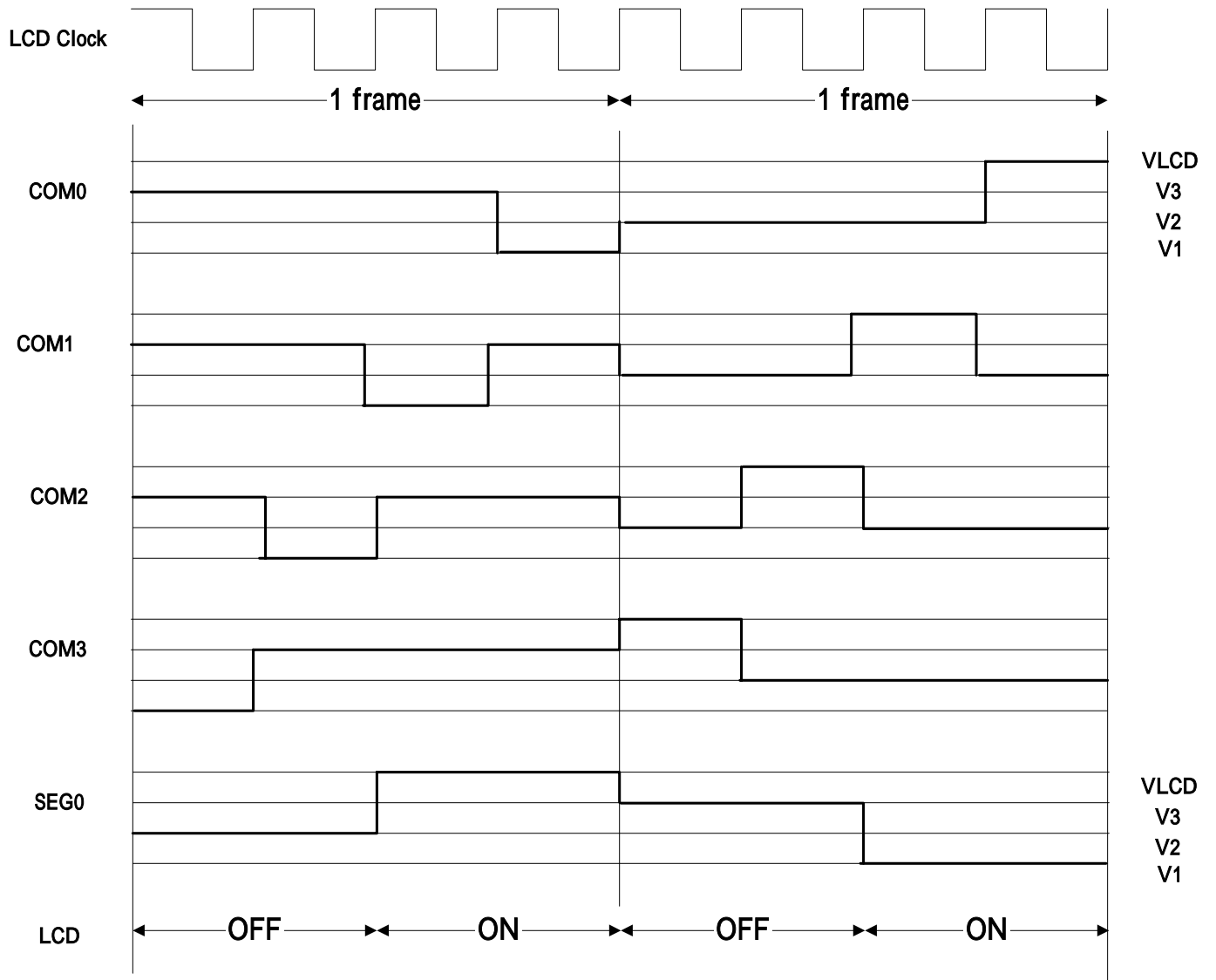

Figure 12-3. LCD Drive Waveform, 1/4 duty, 1/3 bias

LCD RAM LOCATION

RAM bank 15's address vs. Common/Segment pin location

	Bit0	Bit1	Bit2	Bit3	Bit4	Bit5	Bit6	Bit7
	COM0	COM1	COM2	COM3	-	-	-	-
SEG 0	00H.0	00H.1	00H.2	00H.3	-	-	-	-
SEG 1	01H.0	01H.1	01H.2	01H.3	-	-	-	-
SEG 2	02H.0	02H.1	02H.2	02H.3	-	-	-	-
SEG 3	03H.0	03H.1	03H.2	03H.3	-	-	-	-
-	-	-	-	-	-	-	-	-
-	-	-	-	-	-	-	-	-
-	-	-	-	-	-	-	-	-
-	-	-	-	-	-	-	-	-
SEG 14	0EH.0	0EH.1	0EH.2	0EH.3	-	-	-	-
SEG 15	0FH.0	0FH.1	0FH.2	0FH.3	-	-	-	-
SEG 16	10H.0	10H.1	10H.2	10H.3	-	-	-	-
SEG 17	11H.0	11H.1	11H.2	11H.3	-	-	-	-
-	-	-	-	-	-	-	-	-
-	-	-	-	-	-	-	-	-
-	-	-	-	-	-	-	-	-
-	-	-	-	-	-	-	-	-
SEG 29	1DH.0	1DH.1	1DH.2	1DH.3	-	-	-	-
SEG 30	1EH.0	1EH.1	1EH.2	1EH.3	-	-	-	-
SEG 31	1FH.0	1FH.1	1FH.2	1FH.3	-	-	-	-

➡ **Example: Enable LCD function.**

Enable the segment pin shared with PORT2.

```
BOBCLR      FP2SEG      ; Enable SEG24~SEG31
```

Now all LCD pins are enabled. Set the LCD control bit (LCDENB) and program LCD RAM to display LCD panel.

```
BOBSET      FLCDENB     ; LCD driver.
```

13 Charge-Pump, PGIA and ADC

OVERVIEW

The SN8P1900 has a built-in Voltage Charge-Pump/Regulator (CPR) to support a stable voltage 3.8V from pin AVDDR with maximum 10mA current driving capacity. This CPR provides stable voltage for internal circuits (PGIA, ADC) and external sensor (load cell or thermistor). The SN8P1900 series also integrated $\Delta \Sigma$ Analog-to-Digital Converters (ADC) to achieve 16-bit performance and up to 62500-step resolution. The ADC has 3 different input channel modes: (1) Three fully differential inputs (2) Two fully differential inputs and Two single-ended inputs (3) One differential input and Four single-ended inputs. This ADC is optimized for measuring low-level unipolar or bipolar signals in weight scale and medical applications. A very low noise chopper-stabilized programmable gain instrumentation amplifier (PGIA) with selectable gains of 1x, 16x, 32x, 64x, and 128x in the ADC to accommodate these applications.

ANALOG INPUT

Figure 13-1 illustrates a block diagram of the PGIA and ADC module. The front end consists of a multiplexer for input channel selection, a PGIA (Programmable Gain Instrumentation Amplifier), and the $\Delta \Sigma$ ADC modulator.

To obtain maximum range of ADC output, the ADC maximum input signal voltage $V(X+, X-)$ should be close to but can't over the reference voltage $V(R+, R-)$, Choosing a suitable reference voltage and a suitable gain of PGIA can reach this purpose. The relative control bits are RVS [1:0] bits (Reference Voltage Selection) in ADCM register and GS[2:0] bits (Gain Selection) in AMPM register.

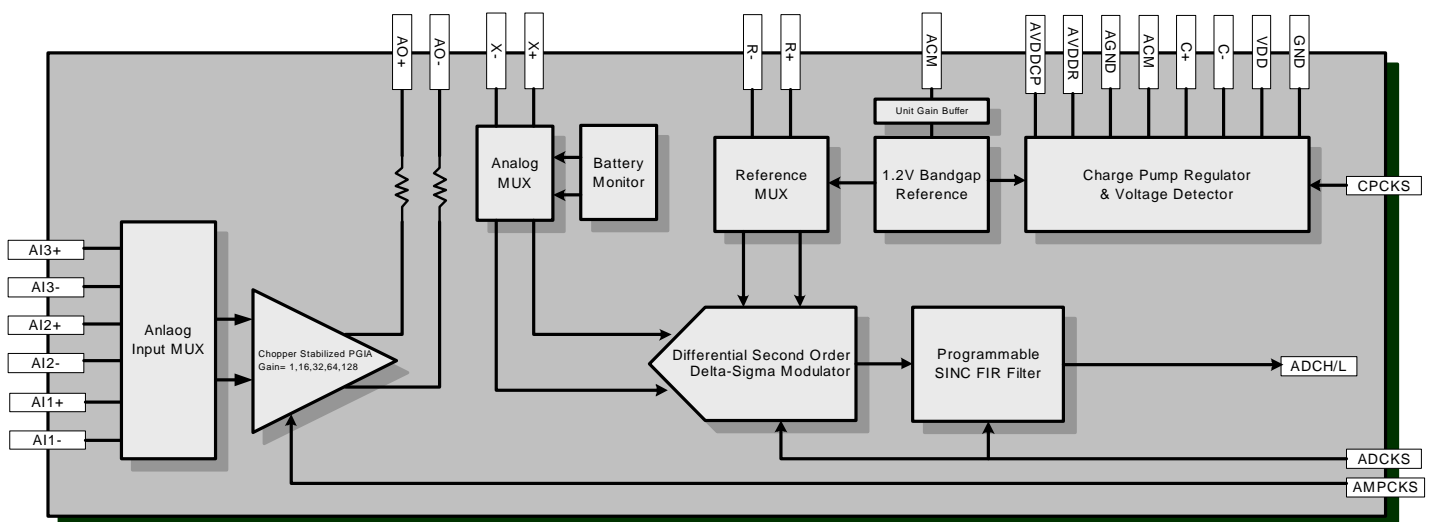

Figure 13-1 Block Diagram of ADC module

- **Note 1:** In figure 13-1, the low pass filter (R1, R2 and C) will filter out chopper frequency of PGIA.
- **Note 2:** The recommend values of R1, R2 are 100K Ω and C is 0.1 μ F. These resistances and capacitor need to place as close chip as possible.

Voltage Charge Pump / Regulator (CPR)

SN8P1900 is built in a CPR which can provide a stable 3.8V (pin AVDDR) with maximum 10mA current driving capacity. Register CPM can enable or disable CPR and controls CPR working mode, another register CPCKS sets CPR working clock to 20KHz. Because the power of PGIA and ADC is come from CPR, turn on CPR (CPRENB = 1) first before enabling PGIA and ADC. In addition, the CPR will need at least 10ms for output voltage stabilization after set CPRENB to high.

CPM-Charge Pump Mode Register

095H	Bit 7	Bit 6	Bit 5	Bit 4	Bit 3	Bit 2	Bit 1	Bit 0
CPM	-	-	-	-	CPSTS	CPAUTO	CPON	CPRENB
	-	-	-	-	R	R/W	R/W	R/W

CPRENB: Charge Pump / Regulator function enable control bit.

0 = Disable charge pump and regulator,
 1 = Enable charge pump and regular.

➤ **Note: 10ms delay is necessary for output voltage stabilization after set CPRENB = "1".**

CPON: Change Pump always ON function control bit (CPRENB must = "1")

0 = Charge Pump On / Off controlled by bit CPAUTO.
 1 = Always turn ON the charge pump regulator.

CPAUTO: Charge Pump Auto Mode function control bit

0 = Disable charge pump auto mode.
 1 = Enable charge pump auto mode.

CPSTS: Charge-Pump status bit in AUTO Mode (Only available when CPAUTO = "1")

0 = Charge-Pump is OFF in Auto mode.
 1 = Charge-Pump is ON in Auto mode.

➤ **Note 1: All current consumptions from AVDDR (including PGIA and ADC) will time 2, when Charge Pump was Enabled.**

➤ Bit CPRENB, CPON, and CPAUTO are Charge-Pump working mode control bit. By these three bits, Charge-Pump can be set as OFF, Always ON, or Auto mode.

CPRENB	CPON	CPAUTO	Charge-Pump Status	Regulator Status	CPSTS	AVDDR	PGIA, ADC Function	
0	X	X	OFF	OFF	N/A	0V	Not Available	
1	0	0	OFF	ON	N/A	See Note1	See Note1	
1	0	1	Auto Mode	ON	0/1	3.8V	Available	
1	1	0	ON	ON	N/A	3.8V	Available	
1	1	1	Reserved (Don't set this mode)					

In Auto Mode, Charge-Pump ON/OFF depended on VDD voltage.

Auto-Mode Description:

CPRENB	CPON	CPAUTO	VDD	Charge-Pump Status	CPSTS	Regulator Status	AVDDR Output	PGIA, ADC Function
1	0	1	>4.1V	OFF	0	ON	3.8V	Available
			4.1V	ON	1	ON	3.8V	Available

➤ **Note 1: When Charge-Pump is OFF and Regulator is ON, VDD voltage must be higher than 3.9V to make sure AVDDR output voltage, PGIA, and ADC functions are working well.**

CPRENB	CPON	CPAUTO	VDD	Charge-Pump Status	Regulator Status	AVDDR Output	PGIA, ADC Function
1	0	0	>4.1V	OFF	ON	3.8V	Available
			4.1V	OFF	ON	Unknown	Not Available

➤ **Note 2: For normally application, set CP as Auto mode (CPAUTO = 1) is strongly recommended.**

➤ **Note 3: If VDD is higher than 5.0V, don't set Charge-Pump as Always ON mode.**

CPCKS-Charge Pump Clock Register

096H	Bit 7	Bit 6	Bit 5	Bit 4	Bit 3	Bit 2	Bit 1	Bit 0
CPCKS	CPCKS7	CPCKS6	CPCKS5	CPCKS4	CPCKS3	CPCKS2	CPCKS1	CPCKS0
W	W	W	W	W	W	W	W	W

CPCKS [7:0] register sets the Charge-Pump working clock; the suggestion Charge-Pump clock is 20K Hz. @ 4MHz

Refer to the following table for CPCKS [7:0] register value setting in different Fosc frequency.

Charge-Pump Clock= (Fosc / (256-CPCKS [7:0])) / 2

CPCKS [7:0]	F _{osc}	CP Working Clock
156	4M	(4M / 100) / 2 = 20K
56	8M	(8M / 200) / 2 = 20K

➤ **Note: In general application, CP working clock is 20K Hz..**

Example: Charge-Pump setting (Fosc = 4M X'tal)

@CPREG_Init:

```

MOV      A, #04h
XB0MOV  CPM, A           ; Set Charge-Pump as Auto Mode
MOV      A, #0156
XB0MOV  CPCKS, A        ; Set CPCKS = 156 for CP working clock = 20K @ 4M X'tal
    
```

@CP_Enable:

```

XB0BSET FCPRENB        ; Enable Charge-Pump / Regulator function
    
```

@Delay_10ms:

```

CALL    @Wait_10ms     ; Delay 10ms for Charge-Pump Stabilize
...
    
```

PGIA -Programmable Gain Instrumentation Amplifier

SN8P1900 includes a low noise chopper-stabilized programmable gain instrumentation amplifier (PGIA) with selection gains of 1x, 16x, 32x, 64x, and 128x by register AMPM. The PGIA also provides three types channel selection mode: (1) Three fully differential inputs (2) Two fully differential inputs and Two single-ended inputs (3) One differential input and Four single-ended inputs, it was defined by register AMPCHS.

AMPM- Amplifier Mode Register

090H	Bit 7	Bit 6	Bit 5	Bit 4	Bit 3	Bit 2	Bit 1	Bit 0
AMPM	-	-	FDS1	FDS0	GS2	GS1	GS0	AMPENB
	-	-	R/W	R/W	R/W	R/W	R/W	R/W

AMPENB: PGIA function enable control bit.
0 = Disable PGIA function
1 = Enable PGIA function

GS [2:0]: PGIA Gain Selection control bit

GS [2:0]	PGIA Gain
000	16
001	32
010	64
011	128
100,101,110	Reserved
111	1

FDS [1:0]: PGIA chopper frequency setting
Set FDS [1:0] = "10" all the time.

AMPCKS- PGIA CLOCK SELECTION

092H	Bit 7	Bit 6	Bit 5	Bit 4	Bit 3	Bit 2	Bit 1	Bit 0
AMPCKS	AMPCKS7	AMPCKS6	AMPCKS5	AMPCKS4	AMPCKS3	AMPCKS2	AMPCKS1	AMPCKS0
	W	W	W	W	W	W	W	W

AMPCKS [7:0] register sets the PGIA working clock, the suggestion PGIA clock is 4K Hz.

Refer to the following table for AMPCKS [7:0] register value setting in different Fosc frequency.

PGIA Clock= (Fosc / (256-AMPCKS [7:0])) / 8

AMPCKS [7:0]	Fosc	PGIA Working Clock
131	4M	(4M / 125) / 8 = 4K
6	8M	(8M / 250) / 8 = 4K

➤ **Note: In general application, PGIA working clock is 4K Hz..**

AMPCHS-PGIA CHANNEL SELECTION

091H	Bit 7	Bit 6	Bit 5	Bit 4	Bit 3	Bit 2	Bit 1	Bit 0
AMPCHS	-	-	-	-	-	CHS2	CHS1	CHS0
	-	-	-	-	-	R/W	R/W	R/W

CHS [2:0]: PGIA Channel Selection

CHS [2:0]	Selected Channel	V (AO+, AO-) Output	Input-Signal Type
000	AI1+, AI1-	$V (AI1+, AI1-) \times PGIA \text{ Gain}$	Differential
001	AI2+, AI2-	$V (AI2+, AI2-) \times PGIA \text{ Gain}$	Differential
010	AI3+, AI3-	$V (AI3+, AI3-) \times PGIA \text{ Gain}$	Differential
011	AI2+, ACM	$V (AI2+, ACM) \times PGIA \text{ Gain}$	Single-ended
100	AI2-, ACM	$V (AI2-, ACM) \times PGIA \text{ Gain}$	Single-ended
101	AI3+, ACM	$V (AI3+, ACM) \times PGIA \text{ Gain}$	Single-ended
110	AI3-, ACM	$V (AI3-, ACM) \times PGIA \text{ Gain}$	Single-ended
111	ACM, ACM	$V (ACM, ACM) \times PGIA \text{ Gain}$	Input-Short

- **Note 1:** $V (AI1+, AI1-) = (AI1+ \text{ voltage} - AI1- \text{ voltage})$
- **Note 2:** $V (AI2-, ACM) = (AI2- \text{ voltage} - ACM \text{ voltage})$
- **Note 3:** The purpose of Input-Short mode is only for PGIA offset testing.
- **Note 4:** When CPR is Disable or system in stop mode, signal on analog input pins must be Zero ("0"V, including AI1+, AI1-, AI2+, AI2-, AI3+, AI3-, X+, X-, R+ and R-) or it will cause the current consumption from these pins.

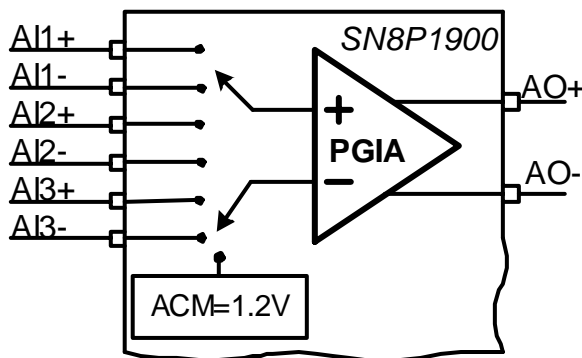

Figure 13-2 Channel Selection Diagram

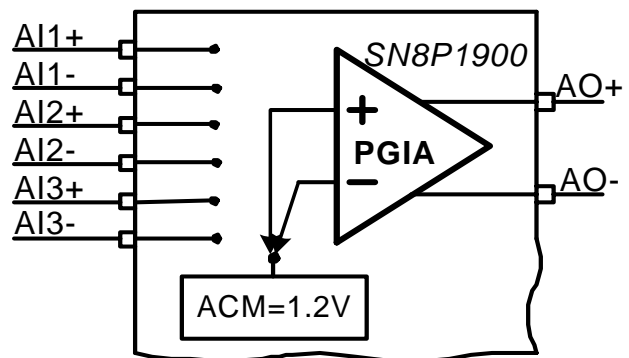

Figure 13-3 Input Short Mode

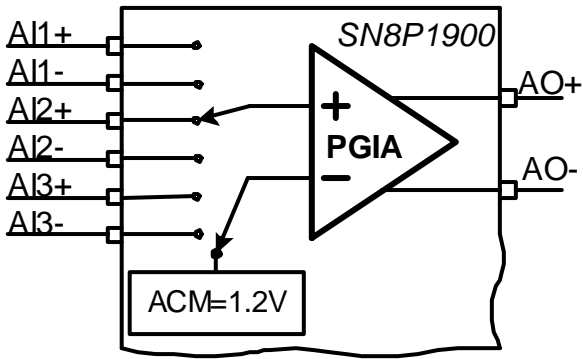

Figure 13-4 Channel Selection: AI2+, ACM

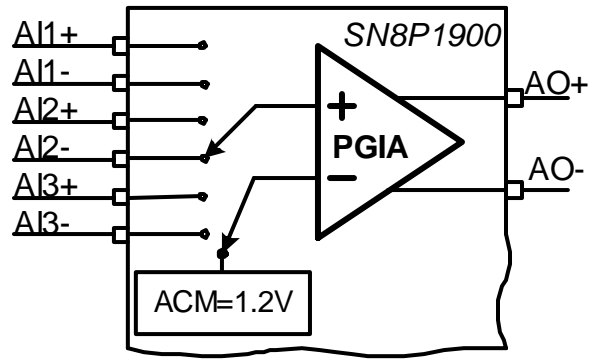

Figure 13-5 Channel Selection: AI2-, ACM

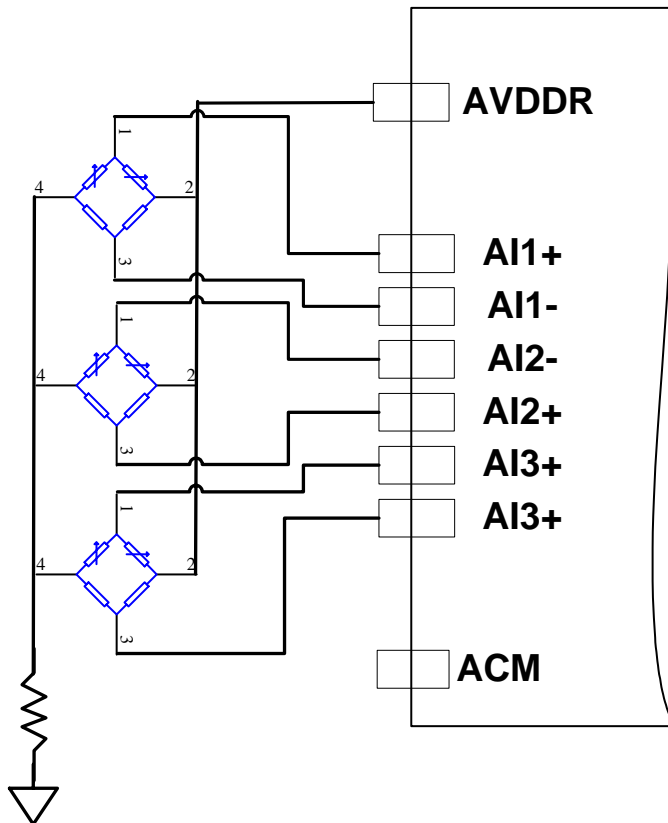

Figure 13-6 Channel configuration mode one: 3 Fully Differential Inputs

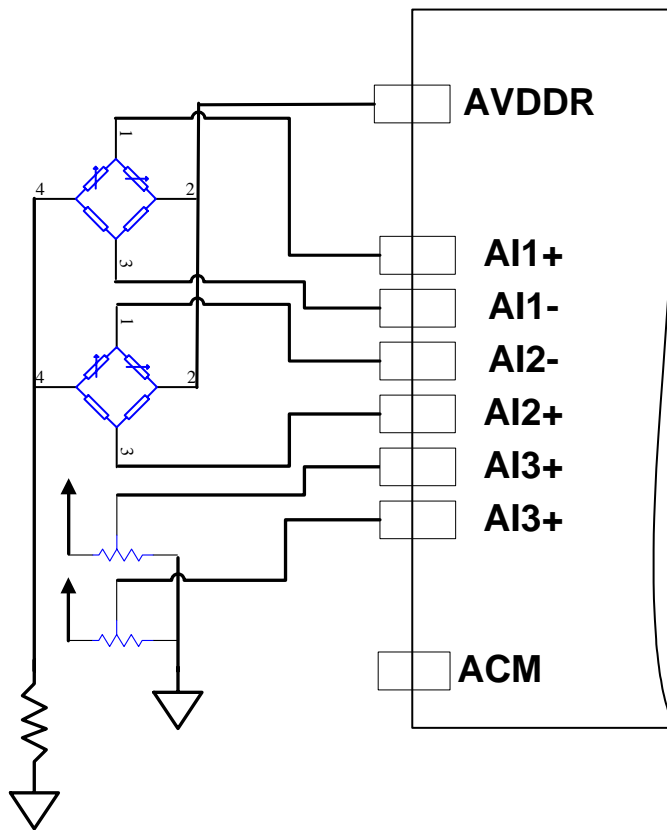

Figure 13-7 Channel configuration mode two: 2 Fully Differential Inputs and 2 Single-ended Inputs

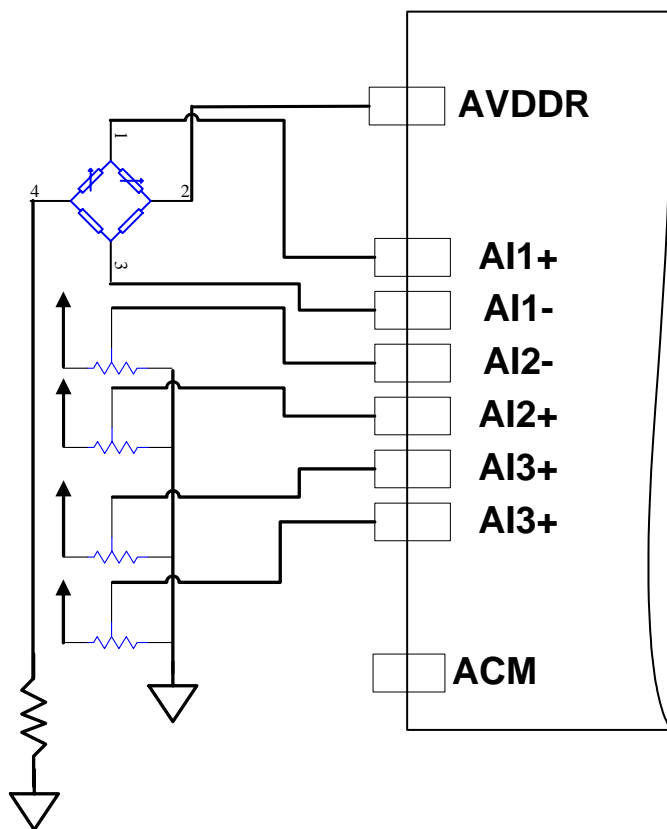

Figure 13-8 Channel configuration mode three: 1 Fully Differential Input and 4 Single-ended Inputs

Example: PGIA setting (Fosc = 4M X'tal)

```

@CPREG_Init:                                ; Enable Charge-Pump/Regulator before PGIA working
MOV      A, #04h
XB0MOV   CPM, A                               ; Set Charge-Pump as Auto Mode
MOV      A, #0156
XB0MOV   CPCKS, A                             ; Set CPCKS = 156 for CP working clock = 20K @ 4M X'tal

@CP_Enable:
XB0BSET  FCPRENB                             ; Enable Charge-Pump / Regulator function

@Delay_10ms:
CALL     @Wait_10ms                          ; Delay 10ms for Charge-Pump Stabilize

@PGIA_Init:
MOV      A, #026h
XB0MOV   AMPM, A                               ; Selected PGIA Gain=128, and FDS [1:0]= "10"
MOV      A, #0131
XB0MOV   AMPCKS, A                            ; Set AMPCKS = 131 for PGIA working clock = 4K @ 4M X'tal
MOV      A, #02h
XB0MOV   AMPCHS, A                            ; Selected PGIA input channel= AI3+, AI3-

@PGIA_Enable
:
XB0BSET  FAMPENB                             ; Enable PGIA function
...      ; V (AO+, AO-) Output = V (AI3+, AI3-) x 128

```

- **Note 1: Enable Charge-Pump/Regulator before PGIA working**
- **Note 2: Please set PGIA relative registers first, then enable PGIA function bit.**

16-Bit ADC

ADCM- ADC Mode Register

093H	Bit 7	Bit 6	Bit 5	Bit 4	Bit 3	Bit 2	Bit 1	Bit 0
ADCM	-	-	-	-	-	RVS1	RVS0	ADCENB
	-	-	-	-	-	R/W	R/W	R/W

ADCENB: ADC function control bit:
0 = Disable 16-bit ADC,
1 = Enable 16-bit ADC

RVS [1:0]: ADC Reference Voltage Selection

RVS [1:0]	AD Reference Voltage		AD Channel Input		Note
	REF+	REF-	ADCIN+	ADCIN-	
00	R+	R-	X+	X-	$V(X+, X-) < V(R+, R-)$
01	Reserved				
10	2.4V	1.2V	X+	X-	$V(X+, X-) < 1.2V$
11	2.4V	1.2V	VDD / 3	VDD / 6	ADC input = 1/6 VDD For battery monitor

➤ **Note 1:** The ADC conversion data is combined with ADCDH and ADCDL register in 2's compliment with sign bit numerical format, and Bit ADCB15 is the sign bit of ADC data. Refer to following formula to calculate ADC conversion data value.

$$(ADCIN+) > (ADCIN-) \Rightarrow ADCConversionData = + \frac{(ADCIN+) - (ADCIN-)}{(REF+) - (REF-)} \times 31250$$

$$(ADCIN+) < (ADCIN-) \Rightarrow ADCConversionData = - \frac{(ADCIN+) - (ADCIN-)}{(REF+) - (REF-)} \times 31250$$

➤ **Note2:** The internal 2.4V and 1.2V reference voltage are generated from Band Gap reference voltage.

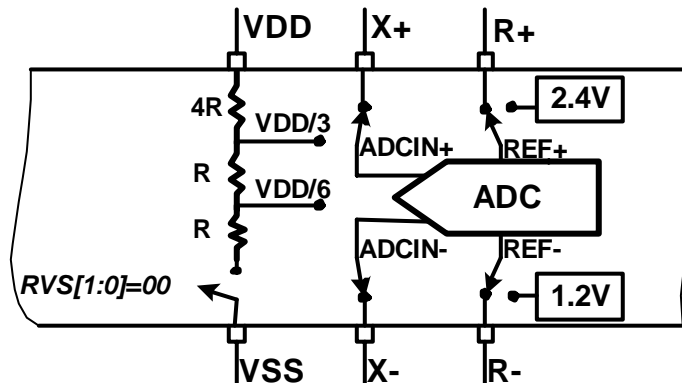

Figure 13-9 Measure V(X+, X-) voltage by external reference voltage.

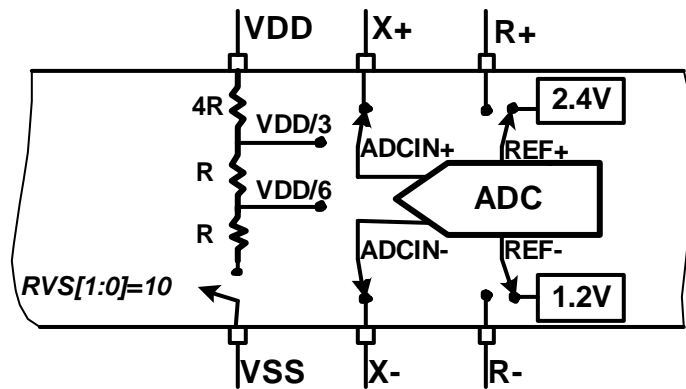

Figure 13-10 Measure $V(X+, X-)$ voltage by internal 2.4V and 1.2V reference voltage

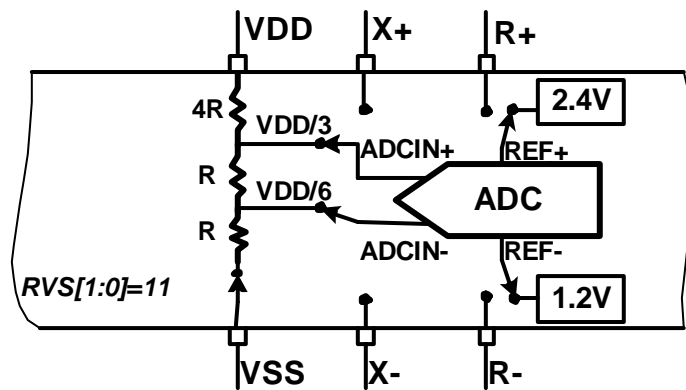

Figure 13-11 Measure VDD (Battery Voltage) by internal 2.4V and 1.2V reference voltage

- **Note :** When CPR is Disable or system in stop mode, signal on analog input pins must be Zero ("0"V, including AI1+, AI1-, AI2+, AI2-, AI3+, AI3-, X+, X-, R+ and R-) or it will cause the current consumption from these pins.

ADCKS- ADC Clock Register

094H	Bit 7	Bit 6	Bit 5	Bit 4	Bit 3	Bit 2	Bit 1	Bit 0
ADCKS	ADCKS7	ADCKS6	ADCKS5	ADCKS4	ADCKS3	ADCKS2	ADCKS1	ADCKS0
	W	W	W	W	W	W	W	W

ADCKS [7:0] register sets the ADC working clock,

Refer the following table for ADCKS [7:0] register value setting in different Fosc frequency.

$$\text{ADC Clock} = (\text{Fosc} / (256 - \text{ADCKS [7:0]})) / 2$$

ADC clock = 200K setting

ADCKS [7:0]	F _{osc}	ADC Working Clock
246	4M	(4M / 10) / 2 = 200K
236	8M	(8M / 20) / 2 = 200K

ADC clock = 100K setting

ADCKS [7:0]	F _{osc}	ADC Working Clock
236	4M	(4M / 20) / 2 = 100K
216	8M	(8M / 40) / 2 = 100K

ADC clock = 80K setting

ADCKS [7:0]	F _{osc}	ADC Working Clock
231	4M	(4M / 25) / 2 = 80K
206	8M	(8M / 50) / 2 = 80K

➤ **Note:** In general application, ADC working clock is 100K Hz.

ADC DL- ADC Low-Byte Data Register

098H	Bit 7	Bit 6	Bit 5	Bit 4	Bit 3	Bit 2	Bit 1	Bit 0
ADC DL	ADCB7	ADCB6	ADCB5	ADCB4	ADCB3	ADCB2	ADCB1	ADCB0
	R	R	R	R	R	R	R	R

ADC DH- ADC High-Byte Data Register

099H	Bit 7	Bit 6	Bit 5	Bit 4	Bit 3	Bit 2	Bit 1	Bit 0
ADC DH	ADCB15	ADCB14	ADCB13	ADCB12	ADCB11	ADCB10	ADCB8	ADCB9
	R	R	R	R	R	R	R	R

ADC DL [7:0]: Output low byte data of ADC conversion word.

ADC DH [7:0]: Output high byte data of ADC conversion word.

- **Note1:** ADC DL [7:0] and ADC DH [7:0] are both read only registers.
- **Note2:** The ADC conversion data is combined with ADC DH, ADC DL in 2's complement with sign bit numerical format, and Bit ADCB15 is the sign bit of ADC data.
ADCB15=0 means data is Positive value, ADCB15=1 means data is Negative value.
- **Note3:** The Positive Full-Scale-Output value of ADC conversion is 0x7A12.
- **Note4:** The Negative Full-Scale-Output value of ADC conversion is 0x85EE.
- **Note5:** Because of the ADC design limitation, the ADC Linear range is +28125~-28125 (decimal). The MAX ADC output must keep inside this range.

ADC conversion data (2's complement, Hexadecimal)	Decimal Value
0x7A12	31250
...	...
0x4000	16384
...	...
0x1000	4096
...	...
0x0002	2
0x0001	1
0x0000	0
0xFFFF	-1
0xFFFE	-2
...	...
0xF000	-4096
...	...
0xC000	-16384
...	...
0x85EE	-31250

DFM-ADC Digital Filter Mode Register

097H	Bit 7	Bit 6	Bit 5	Bit 4	Bit 3	Bit 2	Bit 1	Bit 0
DFM	-	-	-	-	WRS1	WRS0	STOD	DRDY
	-	-	-	-	R/W	R/W	R/W	R/W

DRDY: ADC Data Ready Bit.

“1” = ADC output (update) new conversion data to ADCDH, ADCDL.

“0” = ADCDH, ADCDL conversion data are not ready.

STOD: Stop Output ADC Data.

“0” = ADC is in continuous mode; old data will be replaced continuously by the new one.

“1” = No more new conversion word will update to ADCDH/ADCDL.

WRS [1:0]: ADC output Word Rate Selection:

WRS [1:0]	Output Word Rate		
	ADC clock = 200K	ADC clock = 100K	ADC clock = 80K
00	50 Hz	25 Hz	20 Hz
01	25 Hz	12.5 Hz	10 Hz
10	12.5 Hz	6.25 Hz	5 Hz
11	6.25 Hz	3.125 Hz	2.5 Hz

- **Note 1:** When STOD=0, the ADC is designed for continuous mode, so it needn't read each conversion data every time. User only needs to read the data when conversion result is required. Note that if the conversion data is not read immediately, it could be lost and be replaced by the next new conversion data.
- **Note2:** When STOD = 1, although no more conversion word will update to ADC output buffer, but ADC is still working and will output conversion word when STOD= 0.
- **Note 3:** AC power 50 Hz noise will be filter out when output word rate = 25Hz
- **Note 4:** AC power 60 Hz noise will be filter out when output word rate = 20Hz
- **Note 5:** Both AC power 50 Hz and 60 Hz noise will be filter out when output word rate = 10Hz
- **Note 6:** Clear Bit DRDY after got ADC data or this bit will keep High all the time.

Example: Charge-Pump, PGIA and ADC setting (Fosc = 4M X'tal)

```

@CPREG_Init:                                     ;Enable Charge-Pump/Regulator before PGIA, ADC working
MOV      A, #04h
XB0MOV   CPM, A                                ; Set Charge-Pump as Auto Mode
MOV      A, #0156
XB0MOV   CPCKS, A                              ; Set CPCKS = 156 for CP working clock = 20K @ 4M X'tal

@CP_Enable:
XB0BSET  FCPRENB                               ; Enable Charge-Pump / Regulator function

@Delay_10ms:
CALL     @Wait_10ms                            ; Delay 10ms for Charge-Pump Stabilize

@PGIA_Init:
MOV      A, #026h
XB0MOV   AMPM, A                               ; Selected PGIA Gain=128, and FDS [1:0]= "10"
MOV      A, #0131
XB0MOV   AMPCKS, A                             ; Set AMPCKS = 131 for PGIA working clock = 4K @ 4M X'tal
MOV      A, #02h
XB0MOV   AMPCHS, A                             ; Selected PGIA input channel= AI3+, AI3-

@PGIA_Enable
:
XB0BSET  FAMPENB                               ; Enable PGIA function
                                                ; V (AO+, AO-) Output = V (AI3+, AI3-) x 128

@ADC_Init:
MOV      A, #00H
XB0MOV   ADCM, A                               ; Selection ADC Reference voltage = V(R+, R-)
MOV      A, #0246
XB0MOV   ADCKS, A                              ; Set ADCKS = 246 for ADC working clock = 200K @ 4M X'tal
MOV      A, #00h
XB0MOV   DFM, A                               ; Set ADC as continuous mode and WRS [1:0] = "00" 50 Hz

@ADC_Enable:
XB0BSET  ADCENB                               ; Enable ADC function

@ADC_Wait:
XB0BTS1  FDRDY                               ; Check ADC output new data or not
JMP      @ADC_Wait                            ; Wait for Bit DRDY = 1

@ADC_Read:
XB0BCLR  FDRDY
XB0MOV   A, ADCDH                             ; Move ADC conversion High byte to Data Buffer.
B0MOV   Data_H_Buf, A
XB0MOV   A, ADCDL
B0MOV   Data_L_Buf, A                         ; Move ADC conversion Low byte to Data Buffer.
...

```

- **Note 1: Enable Charge-Pump/Regulator before PGIA working**
- **Note 2: Please set ADC relative registers first, than enable ADC function bit.**

14 APPLICATION CIRCUIT

Scale (Load Cell) Application Circuit

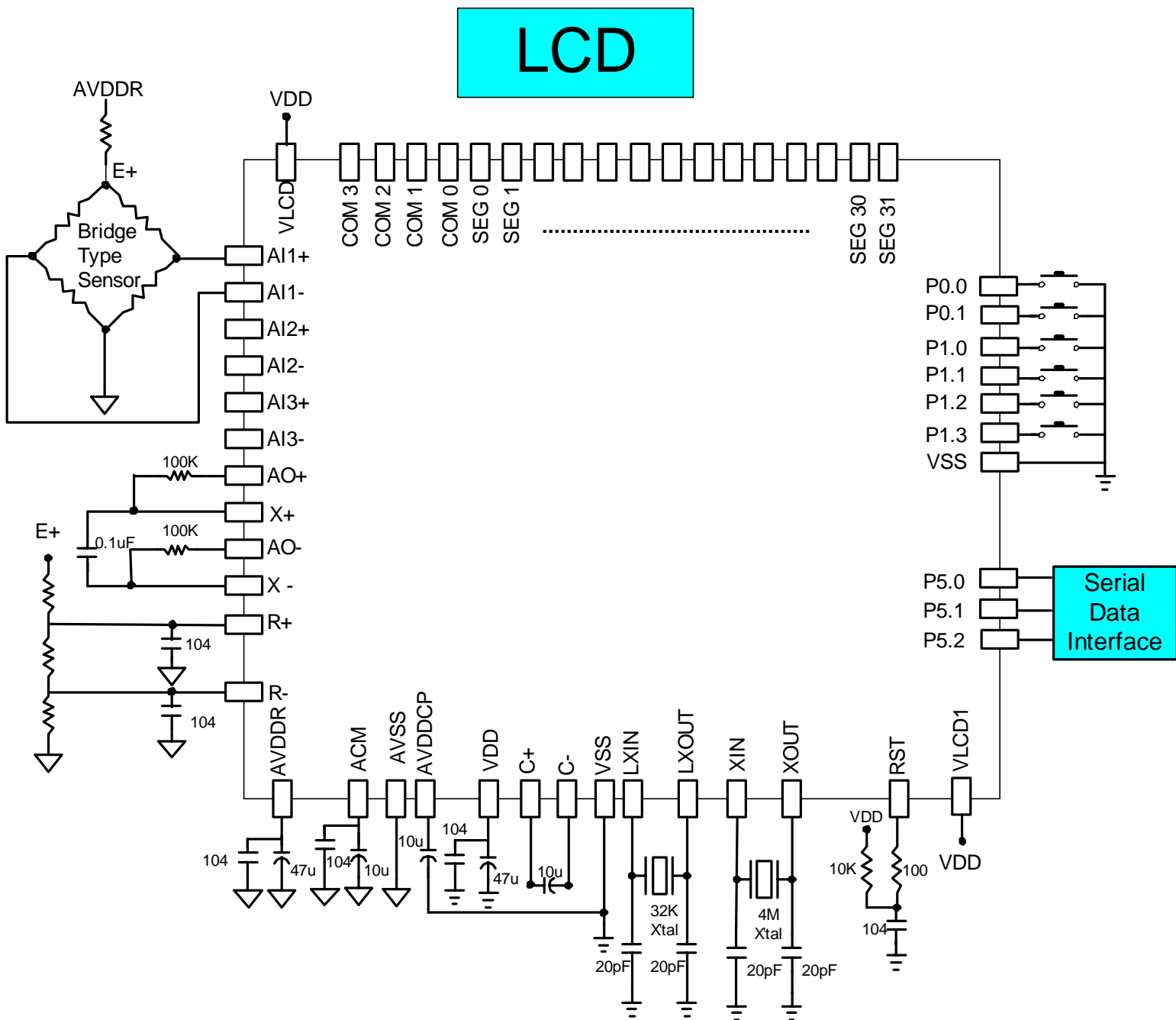

Thermometer Application Circuit

LCD

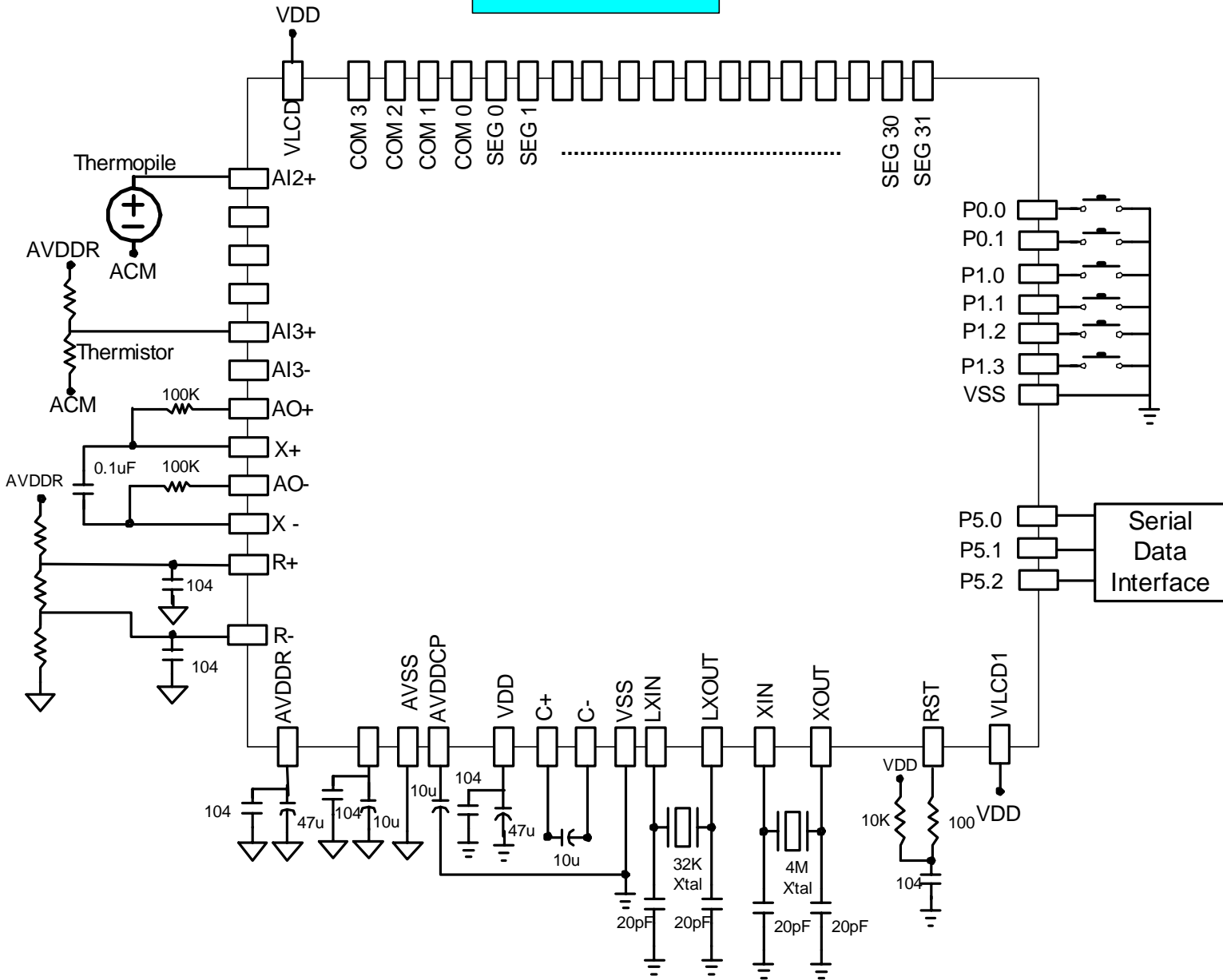

15 INSTRUCTION SET TABLE

Field	Mnemonic	Description	C	DC	Z	Cycle
MOV	MOV A,M	$A \leftarrow M$	-	-	√	1
	MOV M,A	$M \leftarrow A$	-	-	-	1
	B0MOV A,M	$A \leftarrow M$ (bank 0)	-	-	√	1
	B0MOV M,A	M (bank 0) $\leftarrow A$	-	-	-	1
	MOV A,I	$A \leftarrow I$	-	-	-	1
	B0MOV M,I	$M \leftarrow I$, M = only supports 0x80-0x87, (e.g. R, Y, Z, RBANK ,PFLAG,.....)	-	-	-	1
	XCH A,M	$A \leftrightarrow M$	-	-	-	1
	BOXCH A,M	$A \leftrightarrow M$ (bank 0)	-	-	-	1
MOVC	R, A \leftarrow ROM [Y,Z]	-	-	-	2	
ARITH	ADC A,M	$A \leftarrow A + M + C$, if occur carry, then C=1, else C=0	√	√	√	1
	ADC M,A	$M \leftarrow A + M + C$, if occur carry, then C=1, else C=0	√	√	√	1
	ADD A,M	$A \leftarrow A + M$, if occur carry, then C=1, else C=0	√	√	√	1
	ADD M,A	$M \leftarrow A + M$, if occur carry, then C=1, else C=0	√	√	√	1
	BOADD M,A	M (bank 0) $\leftarrow M$ (bank 0) + A, if occur carry, then C=1, else C=0	√	√	√	1
	ADD A,I	$A \leftarrow A + I$, if occur carry, then C=1, else C=0	√	√	√	1
	SBC A,M	$A \leftarrow A - M - /C$, if occur borrow, then C=0, else C=1	√	√	√	1
	SBC M,A	$M \leftarrow A - M - /C$, if occur borrow, then C=0, else C=1	√	√	√	1
	SUB A,M	$A \leftarrow A - M$, if occur borrow, then C=0, else C=1	√	√	√	1
	SUB M,A	$M \leftarrow A - M$, if occur borrow, then C=0, else C=1	√	√	√	1
C	SUB A,I	$A \leftarrow A - I$, if occur borrow, then C=0, else C=1	√	√	√	1
	DAA	To adjust ACC's data format from HEX to DEC.	√	-	-	1
	MUL A,M	R, A $\leftarrow A * M$, The LB of product stored in Acc and HB stored in R register. ZF affected by Acc.	-	-	√	2
LOGIC	AND A,M	$A \leftarrow A$ and M	-	-	√	1
	AND M,A	$M \leftarrow A$ and M	-	-	√	1
	AND A,I	$A \leftarrow A$ and I	-	-	√	1
	OR A,M	$A \leftarrow A$ or M	-	-	√	1
	OR M,A	$M \leftarrow A$ or M	-	-	√	1
	OR A,I	$A \leftarrow A$ or I	-	-	√	1
	XOR A,M	$A \leftarrow A$ xor M	-	-	√	1
	XOR M,A	$M \leftarrow A$ xor M	-	-	√	1
XOR A,I	$A \leftarrow A$ xor I	-	-	√	1	
P	SWAP M	A (b3~b0, b7~b4) \leftarrow M(b7~b4, b3~b0)	-	-	-	1
	SWAPM M	M(b3~b0, b7~b4) \leftarrow M(b7~b4, b3~b0)	-	-	-	1
	RRC M	$A \leftarrow RRC$ M	√	-	-	1
	RRCM M	$M \leftarrow RRC$ M	√	-	-	1
	RLC M	$A \leftarrow RLC$ M	√	-	-	1
	RLCM M	$M \leftarrow RLC$ M	√	-	-	1
	CLR M	$M \leftarrow 0$	-	-	-	1
	BCLR M.b	M.b $\leftarrow 0$	-	-	-	1
	BSET M.b	M.b $\leftarrow 1$	-	-	-	1
	BOBCLR M.b	M(bank 0).b $\leftarrow 0$	-	-	-	1
BOBSET M.b	M(bank 0).b $\leftarrow 1$	-	-	-	1	
BRANCH	CMPRS A,I	ZF,C \leftarrow A - I, If A = I, then skip next instruction	√	-	√	1+S
	CMPRS A,M	ZF,C \leftarrow A - M, If A = M, then skip next instruction	√	-	√	1+S
	INCS M	$A \leftarrow M + 1$, If A = 0, then skip next instruction	-	-	-	1+S
	INCMS M	$M \leftarrow M + 1$, If M = 0, then skip next instruction	-	-	-	1+S
	DECS M	$A \leftarrow M - 1$, If A = 0, then skip next instruction	-	-	-	1+S
	DECMS M	$M \leftarrow M - 1$, If M = 0, then skip next instruction	-	-	-	1+S
	BTS0 M.b	If M.b = 0, then skip next instruction	-	-	-	1+S
	BTS1 M.b	If M.b = 1, then skip next instruction	-	-	-	1+S
	BOBTS0 M.b	If M (bank 0).b = 0, then skip next instruction	-	-	-	1+S
	BOBTS1 M.b	If M (bank 0).b = 1, then skip next instruction	-	-	-	1+S
	JMP d	PC15/14 \leftarrow RomPages1/0, PC13~PC0 \leftarrow d	-	-	-	2
	CALL d	Stack \leftarrow PC15~PC0, PC15/14 \leftarrow RomPages1/0, PC13~PC0 \leftarrow d	-	-	-	2
MISC	RET	PC \leftarrow Stack	-	-	-	2
	RETI	PC \leftarrow Stack, and to enable global interrupt	-	-	-	2
	PUSH	To push working registers (080H~087H) into buffers	-	-	-	1
	POP	To pop working registers (080H~087H) from buffers	√	√	√	1
NOV	NOV	No operation	-	-	-	1

Table 15-1. Instruction Set Table of SN8P1900

Note: Any instruction that read/write from 0SCM, will add an extra cycle.

16 ELECTRICAL CHARACTERISTIC

ABSOLUTE MAXIMUM RATING

Supply voltage (V_{DD}).....	- 0.3V ~ 6.0V
Input in voltage (V_{IN}).....	$V_{SS} - 0.2V \sim V_{DD} + 0.2V$
Operating ambient temperature (T_{OPR}).....	-20°C ~ + 70°C
Storage ambient temperature (T_{STOR}).....	-30°C ~ + 125°C

ELECTRICAL CHARACTERISTIC

(All of voltages refer to V_{SS} , $V_{DD} = 5.0V$, $F_{OSC} = 4MHz$, ambient temperature is 25°C unless otherwise note.)

PARAMETER	SYM.	DESCRIPTION	MIN.	TYP.	MAX.	UNIT	
Operating voltage	V_{DD}	Normal mode, $V_{PP} = V_{DD}$	2.4	5.0	5.5	V	
		Programming mode, $V_{PP} = 12.5V$	-	6.0	-		
OTP programming voltage	V_{PP}	OTP programming voltage	-	12.5	-	V	
RAM Data Retention voltage	V_{DR}		-	2	-	V	
Internal POR	V_{POR}	V_{DD} rise rate to ensure internal power-on reset	-	0.05	-	V/ms	
Input Low Voltage	$ViL1$	All input pins except those specified below	V_{SS}	-	$0.3V_{DD}$	V	
	$ViL2$	Input with Schmitt trigger buffer	V_{SS}	-	$0.2V_{DD}$	V	
	$ViL3$	Reset pin; Xin (in RC mode)	V_{SS}	-	$0.2V_{DD}$	V	
	$ViL4$	Xin (in X'tal mode)	V_{SS}	-	$0.3V_{DD}$	V	
Input High Voltage	$ViH1$	All input pins except those specified below	$0.7V_{DD}$	-	V_{DD}	V	
	$ViH2$	Input with Schmitt trigger buffer	$0.8V_{DD}$	-	V_{DD}	V	
	$ViH3$	Reset pin; Xin (in RC mode)	$0.9V_{DD}$	-	V_{DD}	V	
	$ViH4$	Xin (in X'tal mode)	$0.7V_{DD}$	-	V_{DD}	V	
Reset pin leakage current	I_{LEKG}	$V_{IN} = V_{DD}$	-	-	1	mA	
I/O port pull-up resistor	R_{UP}	$V_{IN} = V_{SS}$, $V_{DD} = 5V$	-	100	-	KΩ	
I/O port input leakage current	I_{LEKG}	Pull-up resistor disable, $V_{IN} = V_{DD}$	-	-	1	mA	
All Port source current sink current	I_{OH}	$V_{OP} = V_{DD} - 0.5V$	-	15	-	mA	
	I_{OL}	$V_{OP} = V_{SS} + 0.5V$	-	15	-		
INT_N trigger pulse width	T_{INT0}	$INT0 \sim INT1$ interrupt request pulse width	$2/F_{CPU}$	-	-	Cycle	
Supply Current (Disable Analog part / LCD)	Idd1	Run Mode (Low Power Disable)	$V_{dd} = 5V$ 4Mhz	-	3	5	mA
			$V_{dd} = 3V$ 4Mhz	-	1	2	mA
			$V_{dd} = 3V$ 32768Hz	-	40	-	uA
	Idd2	Run Mode (Low Power Enable)	$V_{dd} = 5V$ 4Mhz	-	2	3	mA
			$V_{dd} = 3V$ 4Mhz	-	0.7	1.4	mA
	Idd3	Slow mode (Stop High Clock)	$V_{dd} = 5V$ 32768Hz	-	50	75	uA
			$V_{dd} = 3V$ 32768Hz	-	15	25	uA
	Idd4	Sleep mode	$V_{dd} = 5V$	-	1	2	uA
			$V_{dd} = 3V$	-	-	1	uA
	Idd5	Green Mode (Stop High Clock)	$V_{dd} = 5V$ 32768Hz	-	30	50	uA
$V_{dd} = 3V$ 32768Hz			-	10	15	uA	
LVD detect level	V_{LVD}	Internal POR detect level	-	1.8	-	V	

(All of voltages refer to AVDDR=3.8V $F_{OSC} = 4\text{MHz}$, ambient temperature is 25°C unless otherwise note.)

PARAMETER	SYM.	DESCRIPTION	MIN.	TYP.	MAX.	UNIT
Analog to Digital Converter						
Operating current	I _{DD_ADC}	Run mode @ AVDDR = 3.8V		800	1000	μA
Power down current	I _{PDN}	Stop mode @ AVDDR = 3.8V		0.1	1	μA
Conversion rate	F _{SMP}	ADCKS: 100KHz			25	sps
Reference Voltage Input Voltage	V _{ref1}	R+, R- Input Voltage	0.4		2.0	V
	V _{ref2}	Differential Voltage in R+ and R-	0.3			V
Differential non-linearity	DNL	ADC range ± 28125		±0.5	±0.5	LSB
Integral non-linearity	INL	ADC range ± 28125		±1	±4	LSB
No missing code	NMC	ADC range ± 28125		16		bit
Noise free code	NFC	ADC range ± 28125		14	16	bit
Effective number of bits	ENOB	ADC range ± 28125		14	16	bit
ADC Input range	V _{AIN}		0.4		2.0	V
PGIA						
Current consumption	I _{DD_PGIA}	Run mode @ AVDDR = 3.8V		300	500	μA
Power down current	I _{PDN}	Stop mode @ AVDDR = 3.8V		0.1		μA
Input offset voltage	V _{OS}			2		μV
Bandwidth	BW			100		Hz
PGIA Input Range	V _{opin}	AVDDR = 3.8V	0.4		2	V
PGIA Output Range	V _{opout}	AVDDR = 3.8V	0.4		2	V
Charge pump regulator						
Supply voltage	V _{CPS}	Normal mode	2.4		5.5	V
Regulator output voltage	V _{CPO}	AVDDR pin output voltage	3.650	3.800	3.950	V
Analog common voltage	V _{ACM}	ACM pin voltage	1.15	1.2	1.25	V
Reference Voltage Temperature Coefficient	T _{ACM}	ACM pin voltage		50		PPM/
Regulator output current capacity	I _{VA+}	AVDDR pin driving current	10			mA
Quiescent current	I _{QI}			700		μA
V _{ACM} driving capacity	I _{SRC}	ACM pin driving current		10		μA
V _{ACM} sinking capacity	I _{SNK}	ACM pin sink current	1			mA

17 PACKAGE INFORMATION

LQFP64:

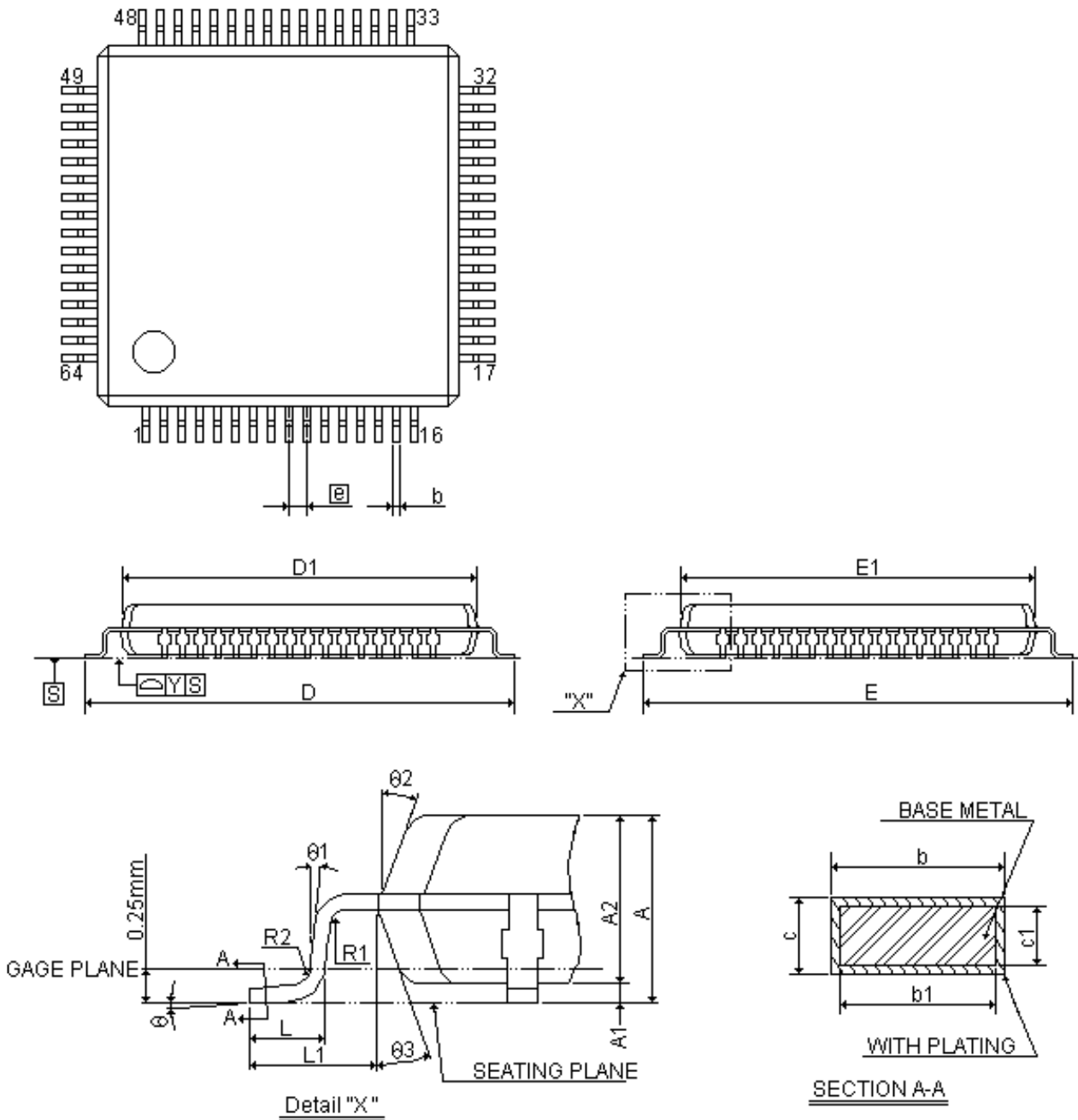

SYMBLE	DIMENSION (MM)			DIMENSION (MIL)		
	MIN.	NOM.	MAX.	MIN.	NOM.	MAX.
A			1.60			63
A1	0.05	1.40	0.15	2	55	6
A2	1.36	0.22	1.45	35	9	57
b	0.17	0.22	0.27	7	8	11
b1	0.17		0.23	7		12
c	0.09		0.20	4		8
c1	0.09		0.16	4		6
D	11.75	12.00	12.25	463	473	483
D1	9.95	10.00	10.05	392	394	396
E	11.75	12.00	12.25	463	473	483
E1	9.95	10.00	10.05	392	394	396
[e]		0.50			20	
L	0.45	0.60	0.75	18	24	30
L1	0.9	1	1.1		39	
R1	0.08			3		
R2	0.08		0.20	3		8
Y			0.075			3
θ	0°	3.5°	7°	0°	3.5°	7°
θ 1	0°			0°		
θ 2	11°	12°	13°	11°	12°	13°
θ 3	11°	12°	13°	11°	12°	13°

LQFP80

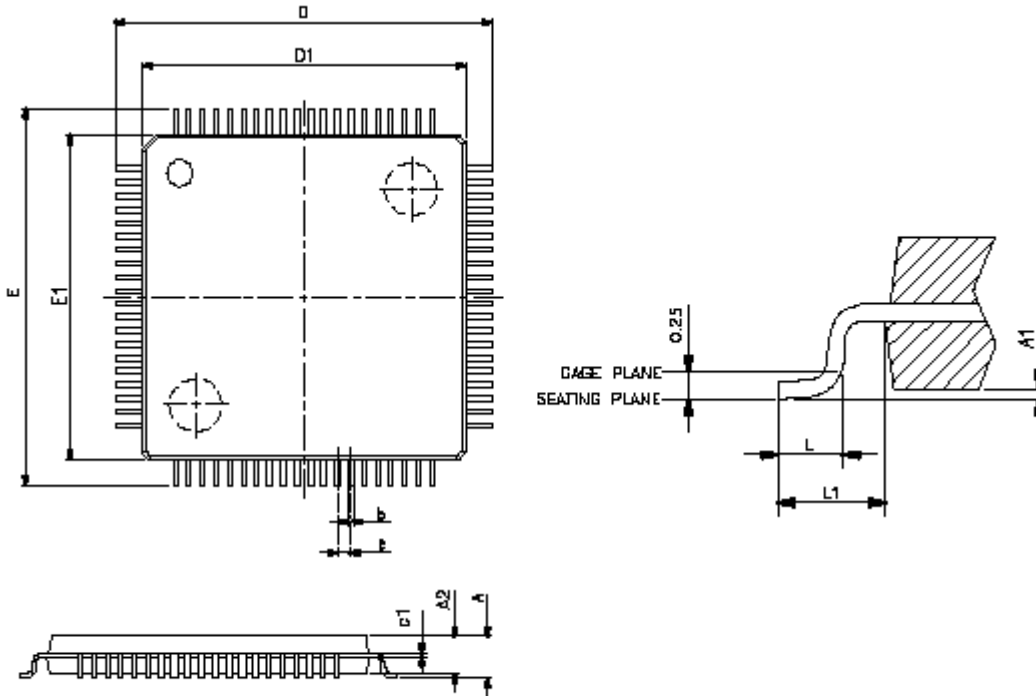

VARIATIONS (ALL DIMENSIONS SHOWN IN MM)

SYMBOLS	MIN.	MAX.
A	--	1.6
A1	0.05	0.15
A2	1.35	1.45
e1	0.09	0.16
D	12 BSC	
D1	10 BSC	
E	12 BSC	
E1	10 BSC	
e	0.4 BSC	
b	0.17	0.27
L	0.45	0.75
L1	1 REF	

SONIX reserves the right to make change without further notice to any products herein to improve reliability, function or design. SONIX does not assume any liability arising out of the application or use of any product or circuit described herein; neither does it convey any license under its patent rights nor the rights of others. SONIX products are not designed, intended, or authorized for use as components in systems intended, for surgical implant into the body, or other applications intended to support or sustain life, or for any other application in which the failure of the SONIX product could create a situation where personal injury or death may occur. Should Buyer purchase or use SONIX products for any such unintended or unauthorized application. Buyer shall indemnify and hold SONIX and its officers, employees, subsidiaries, affiliates and distributors harmless against all claims, cost, damages, and expenses, and reasonable attorney fees arising out of, directly or indirectly, any claim of personal injury or death associated with such unintended or unauthorized use even if such claim alleges that SONIX was negligent regarding the design or manufacture of the part.

Main Office:

Address: 9F, NO. 8, Hsien Cheng 5th St, Chupei City, Hsinchu, Taiwan R.O.C.

Tel: 886-3-551 0520

Fax: 886-3-551 0523

Taipei Office:

Address: 15F-2, NO. 171, Song Ted Road, Taipei, Taiwan R.O.C.

Tel: 886-2-2759 1980

Fax: 886-2-2759 8180

Hong Kong Office:

Address: Flat 3 9/F Energy Plaza 92 Granville Road, Tsimshatsui East Kowloon.

Tel: 852-2723 8086

Fax: 852-2723 9179

Technical Support by Email:

Sn8fae@sonix.com.tw