

DIESEL GENERATOR SET

WATER CHARGE-AIR COOLING

890kVA/50 Hz/Standby (Fuel-Optimized)
380 - 415V



Optional equipment shown. Standard equipment may vary.

BENEFITS

- // Low installation costs
- // Superior fuel consumption values
- // Long maintenance intervals
- // Best-in-class reliability and availability
- // Lifting vertically or with diagonal pull
- // Compact design

SYSTEM RATINGS^①

Standby	DS00890D5S	DS00890D5S	DS00890D5S
Voltage (L-L)	380V	400V	415V
Phase	3	4	3
PF	0.8	0.8	0.8
Hz	50	50	50
kW	704	712	664
kVA	880	890	830
Amps	1337	1285	1155
Generator model	574RSL7066	574RSL7066	574RSL7066
Temp rise	150 °C/40 °C	150 °C/40 °C	150 °C/40 °C
Connection	6 LEAD HI WYE	6 LEAD HI WYE	6 LEAD HI WYE

^① Power available up to 40°C/400 m

CERTIFICATIONS AND STANDARDS

- // Engine-generator set is designed and manufactured in facilities certified to standards ISO 9001:2008 and ISO 14001:2004
- // Performance Assurance Certification (PAC)
 - Engine-generator set tested according to ISO 8528-5 for transient response
 - Verified product design, quality and performance integrity
 - All engine systems are type and factory tested
- // Power Rating
 - Permissible average power output during 24 hours of operation up to 85%

STANDARD EQUIPMENT^①

// Engine

Air filters
 Oil pump for draining
 Full flow oil filters
 Closed crankcase ventilation
 Jacket water pump
 Thermostats
 Exhaust manifold – dry
 Belt driven radiator fan
 Radiator – unit mounted
 Electric starting motor – 24V
 Governor – electronic isochronous
 Base – formed steel
 SAE flywheel & bell housing
 Charging alternator
 Flexible fuel connectors
 Flexible exhaust connection

// Generator

NEMA MG1, IEEE and ANSI standards compliance for temperature rise and motor
 VDE 0530, IEC 60034-1, BS4999, BS5000, CSA22.2-100, AS 1359
 Sustained short circuit current of up to 250% of the rated current for up to 10 seconds
 Self-ventilated and drip-proof according to IP23
 Superior voltage waveform
 Digital, volts-per-hertz regulator
 No load to full load regulation
 Brushless alternator with brushless pilot exciter
 4 Pole, rotating field
 150 °C maximum standby temperature rise
 Heavy duty shielded ball bearings with a minimum B-10 life of 40,000 hrs
 Flexible coupling
 Full amortisseur windings
 3-phase voltage sensing
 ±0.25% voltage regulation
 100% of rated load – one step according to NFPA 110
 3% maximum harmonic content

^① Represents standard product only. Consult Factory/MTU Onsite Energy distributor for additional configurations.

STANDARD FEATURES^①

- // The engine-generator set complies to G3
- // Engine generator set tested according to ISO 8528-5 for transient response
- // Accepts rated load in one step as per NFPA 110
- // All engine-generator sets are type and factory tested
- // MTU Onsite Energy is a single source supplier
- // Global product support
- // 12V2000 diesel engine (23,88 liter (1457 cu inch) displacement; 4-stroke)
- // Engine-generator resiliently mounted
- // Complete range of accessories
- // Brushless, rotating field generator (PMG excitation; 250% short circuit capability; 2/3 pitch stator windings)
- // Complete system metering
- // LCD display

APPLICATION DATA

// Engine

Manufacturer	MTU
Model	12V2000G65TB
Type	4-Stroke
Arrangement	12-V
Displacement/cylinder: l (cu inch)	1.99 (121)
Bore: mm (inch)	130 (5.1)
Stroke: mm (inch)	150 (5.9)
Compression ratio	16:1
Rated speed rpm	1500
Engine governor	Electronic isochronous
Max power: kWm (bhp)	765 (1026)
Speed regulation	±0.25%
Air filter	Dry

// Lube Oil Capacity

Total oil system: l (gal)	77 (20)
---------------------------	---------

// Electrical

Electric Volts DC	24
Cold cranking amps under -17.8 °C (0 °F)	1000

// Fuel System

Fuel supply connection size	M22x1,5 - 60°/Male
Fuel return connection size	M12x1,5 - 60°/Male
Maximum fuel lift: m (ft)	5 (16)
Recommended fuel	see MTU fluids & lubrication spec.
Total fuel flow: l/hr (gal/hr)	480 (127)

// Fuel Consumption^②

	gal/hr	l/hr	g/kwh
At 100% of power rating:	49	187	203
At 75% of power rating:	37	140	202
At 50% of power rating:	25	96	208

// Cooling/Radiator System

Water pump capacity: l/min (gpm)	667 (176)
Heat rejection to coolant: kW (BTUM)	305(17,345)
Heat rejection to after cooler: kW (BTUM)	185 (10,521)
Heat radiated to ambient: kW (BTUM)	40 (2,275)
Engine coolant capacity: l (gal)	110 (29)

// Air Requirements^③

Aspirating: m ³ /min (SCFM)	54 (1905)
--	-----------

// Exhaust System

Gas temp. (stack): °C (°F)	565 (1049)
Gas volume flow temp: m ³ /min (SCFM)	150 (5277)
Maximum allowable back pressure: kPA	8.5

① Represents standard product only. Consult Factory/MTU Onsite Energy distributor for additional configurations.

② Values in accordance with ISO 3046-1. Conversion calculated with fuel density of 0.83 g/ml.

③ Air density = 1.184 kg/m³ (0.0739 lbm/ft³)

WEIGHTS AND DIMENSIONS

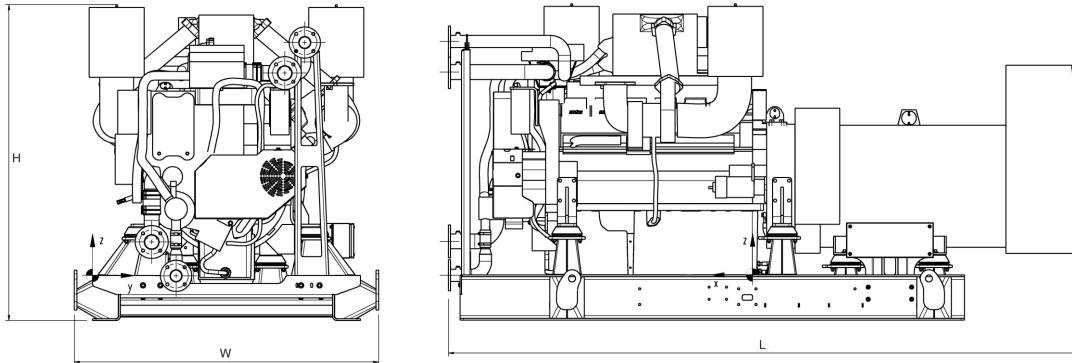

Drawing above for illustration purposes only, based on a standard open power 400 Volt engine-generator set. Lengths may vary with other voltages. Do not use for installation design. See website for unit specific template drawings.

System	Dimensions (L x W x H)	Weight (dry)
Open Power Unit (OPU)	3648 x 1750 x 1805 mm (143.6 x 69 x 71.1 inch)	4891 kg (10,783 lbs)

Weights and dimensions are based on open power units and are estimates only. Consult the factory for accurate weights and dimensions for your specific engine-generator set.

SOUND DATA

// Consult your local MTU Onsite Energy distributor for sound data.

EMISSIONS DATA

// Consult your local MTU Onsite Energy distributor for emissions data.

RATING DEFINITIONS AND CONDITIONS

// Standby ratings apply to installations served by a reliable utility source. The standby rating is applicable to varying loads for the duration of a power outage. No overload capability for this rating. Ratings are in accordance with ISO 8528-1, ISO3046-1, BS5514, AS 2789 and DIN6271.

// Deration factor:

Altitude: Consult your local MTU Onsite Energy distributor for altitude derations.

Temperature: Consult your local MTU Onsite Energy distributor for temperature derations.

Materials and specifications subject to change without notice.