Description

The CXG1216UR can be used in wireless communication systems, for example, dual-band and triple-band CDMA handsets.

This IC has on-chip logic for operation with 4 COMS control inputs.

The Sony JPHEMT process is used for low insertion loss and on-chip logic circuit.

(Applications: Antenna switch for cellular handsets, dual-band and triple-band CDMA)

Features

- ◆ Low insertion loss: 0.35dB@900MHz, 0.50dB@2GHz
- ◆ 4 CMOS compatible control line

Package

Small package size: 20-pin UQFN

Structure

GaAs JPHEMT MMIC

Absolute Maximum Ratings

(Ta = 25°C)

◆ Input power max. (RF port)	Pin	34	dBm
◆ Bias voltage	V _{DD}	7	V
◆ Control voltage	V _{ctl}	5	V
◆ Operating temperature	Topr	-35 to +85	°C
◆ Storage temperature	Tstg	-65 to +150	°C

This IC is an ESD sensitive device. Special handling precautions are required.
The actual ESD test data will be available later.

Sony reserves the right to change products and specifications without prior notice. This information does not convey any license by any implication or otherwise under any patents or other right. Application circuits shown, if any, are typical examples illustrating the operation of the devices. Sony cannot assume responsibility for any problems arising out of the use of these circuits.

Block Diagram and Recommended Circuit

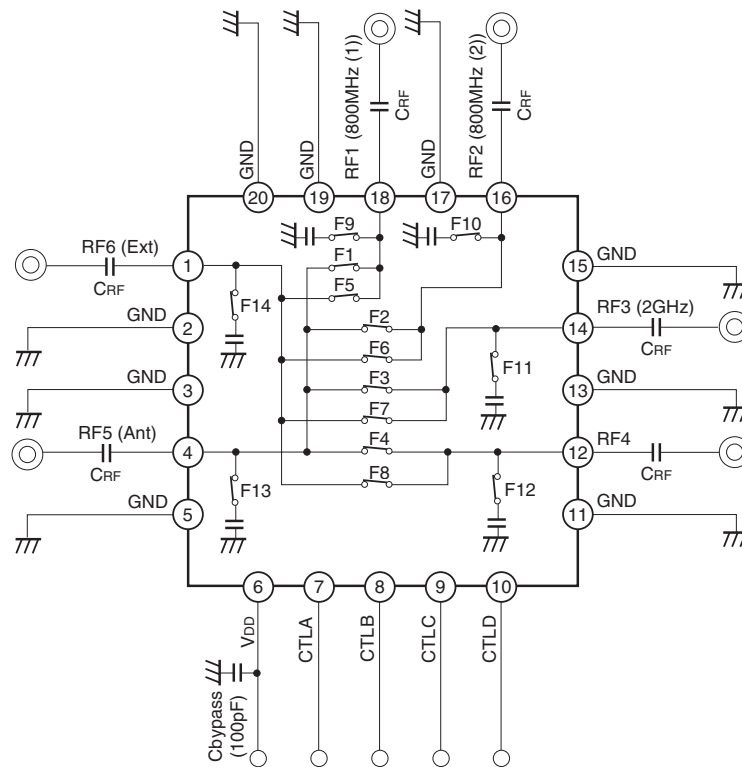

When using this IC, the following external components should be used:

CRF: This capacitor is used for RF decoupling and must be used for all applications.

Cbypass: This capacitor is used for DC line filtering.

Truth Table

State	CTLA	CTLB	CTLC	CTLD	ON state	F1	F2	F3	F4	F5	F6	F7	F8	F9	F10	F11	F12	F13	F14
1	L	L	H	L	RF5-1 (800MHz(1)-Ant)	ON	OFF	OFF	OFF	OFF	OFF	OFF	OFF	OFF	ON	ON	ON	OFF	ON
2	L	L	H	H	RF5-2 (800MHz(2)-Ant)	OFF	ON	OFF	OFF	OFF	OFF	OFF	OFF	ON	OFF	ON	ON	OFF	ON
3	L	H	H	L	RF5-3 (2GHz-Ant)	OFF	OFF	ON	OFF	OFF	OFF	OFF	OFF	ON	ON	OFF	ON	OFF	ON
4	H	L	H	L	RF5-4 (RF4-Ant)	OFF	OFF	OFF	ON	OFF	OFF	OFF	OFF	ON	ON	ON	OFF	OFF	ON
5	L	L	L	L	RF6-1 (800MHz(1)-Ext)	OFF	OFF	OFF	OFF	ON	OFF	OFF	OFF	OFF	ON	ON	ON	ON	OFF
6	L	L	L	H	RF6-2 (800MHz(2)-Ext)	OFF	OFF	OFF	OFF	OFF	ON	OFF	OFF	ON	OFF	ON	ON	ON	OFF
7	L	H	L	L	RF6-3 (2GHz-Ext)	OFF	OFF	OFF	OFF	OFF	OFF	ON	OFF	ON	ON	OFF	ON	ON	OFF
8	H	L	L	L	RF6-4 (RF4-Ext)	OFF	OFF	OFF	OFF	OFF	OFF	OFF	ON	ON	ON	ON	OFF	ON	OFF

DC Bias Conditions

(Ta = 25°C)

Item	Min.	Typ.	Max.	Unit
Vctl (H)	1.5	2.6	3.2	V
Vctl (L)	0	—	0.5	V
VDD	2.6	2.85	3.2	V

Pin Description

Pin No.	Symbol	Pin No.	Symbol
1	RF6 (Ext)	11	GND
2	GND	12	RF4
3	GND	13	GND
4	RF5 (Ant)	14	RF3 (2GHz)
5	GND	15	GND
6	VDD	16	RF2 (800MHz (2))
7	CTLA	17	GND
8	CTLB	18	RF1 (800MHz (1))
9	CTLC	19	GND
10	CTLD	20	GND

Electrical Characteristics

(Ta = 25°C, V_{DD} = 2.85V)

Item	Symbol	Condition	Min.	Typ.	Max.	Unit
Insertion loss	IL	830 to 930MHz		0.35	0.55	dB
		1575.42MHz		0.40	0.60	dB
		1.92 to 2.17GHz		0.50	0.70	dB
Isolation	ISO	830 to 930MHz	25	32		dB
		1575.42MHz	23	30		dB
		1.92 to 2.17GHz	20	30		dB
VSWR	VSWR	50Ω		1.2		—
Switching speed	TSW			5	10	μs
1dB compression input power	P1dB	V _{DD} = 2.85V		32		dBm
Harmonics	2fo	*1		-70	-65	dBc
	3fo	*1		-70	-65	dBc
	2fo	*2		-65	-60	dBc
	3fo	*2		-65	-60	dBc
Input IP3	IIP3	*3	55	60		dBm
		*4	55	60		dBm
Bias current	I _{DD}	V _{DD} = 2.85V		200	250	μA
Control current	I _{ctl}	V _{ctl} (H) = 2.6V to 1.5V		0		μA
		V _{ctl} (L) = 0V	-8	-5	-3	μA

*1 Pin = 25dBm, 0/2.6V control, V_{DD} = 2.85V, 890 to 930MHz

*2 Pin = 25dBm, 0/2.6V control, V_{DD} = 2.85V, 1.92 to 1.98GHz

*3 Pin = 25dBm (900MHz) + 25dBm (901MHz), 0/2.6V control, V_{DD} = 2.85V

*4 Pin = 25dBm (1.9GHz) + 25dBm (1.901GHz), 0/2.6V control, V_{DD} = 2.85V

Package Outline

(Unit: mm)

20PIN UQFN (PLASTIC)

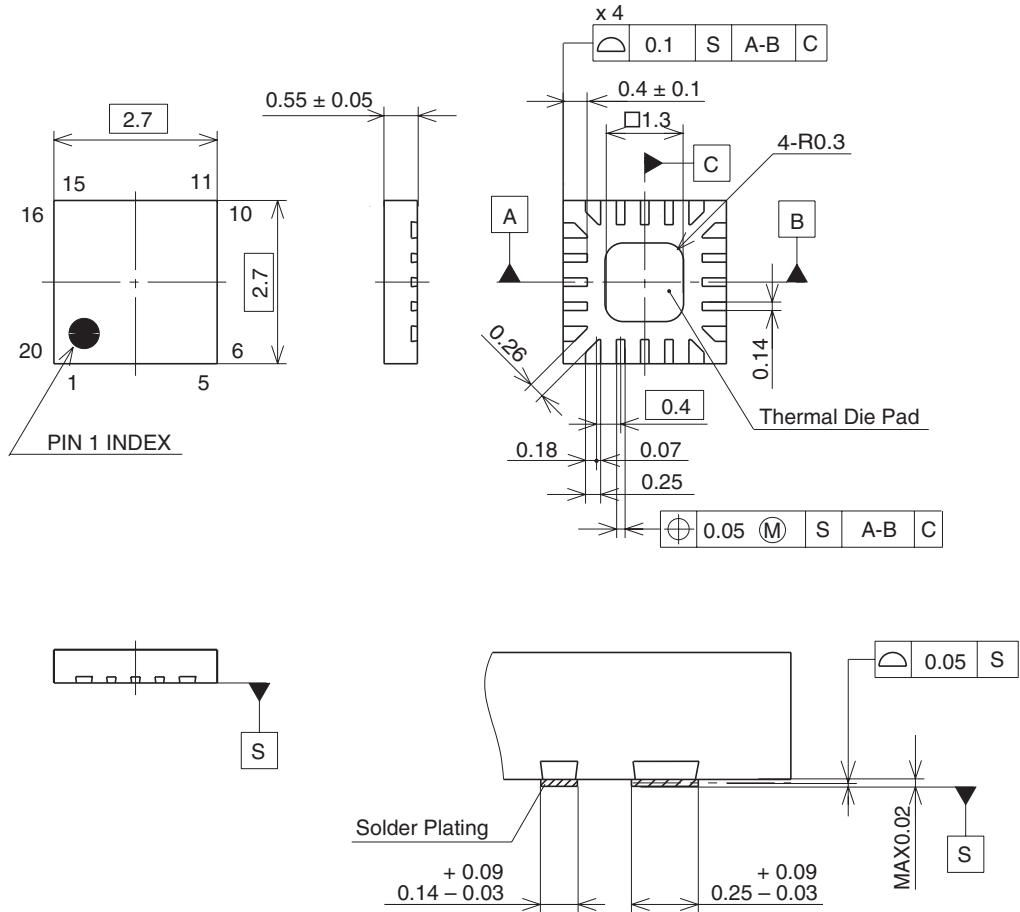

TERMINAL SECTION

Note:Cutting burr of lead are 0.05mm MAX.

SONY CODE	UQFN-20P-01
EIAJ CODE	_____
JEDEC CODE	_____

PACKAGE STRUCTURE

PACKAGE MATERIAL	EPOXY RESIN
LEAD TREATMENT	SOLDER PLATING
LEAD MATERIAL	COPPER ALLOY
PACKAGE MASS	0.02g

LEAD PLATING SPECIFICATIONS

ITEM	SPEC.
LEAD MATERIAL	COPPER ALLOY
SOLDER COMPOSITION	Sn-Bi Bi:1-4wt%
PLATING THICKNESS	5-18µm