

PTN3381B

Enhanced performance HDMI/DVI level shifter with voltage regulator, dongle detect support and active DDC buffer

Rev. 2 — 15 October 2010

Product data sheet

1. General description

The PTN3381B is a high-speed level shifter device which converts four lanes of low-swing AC-coupled differential input signals to DVI v1.0 and HDMI v1.3a compliant open-drain current-steering differential output signals, up to 1.65 Gbit/s per lane. Each of these lanes provides a level-shifting differential buffer to translate from low-swing AC-coupled differential signaling on the source side, to TMDS-type DC-coupled differential current-mode signaling terminated into 50 Ω to 3.3 V on the sink side. Additionally, the PTN3381B provides a single-ended active buffer for voltage translation of the HPD signal from 5 V on the sink side to 3.3 V on the source side and provides a channel with active buffering and level shifting of the DDC channel (consisting of a clock and a data line) between 3.3 V source-side and 5 V sink-side. The DDC channel is implemented using active I²C-bus buffer technology providing capacitive isolation, redriving and level shifting as well as disablement (isolation between source and sink) of the clock and data lines.

To provide the highest level of integration in external adapter (or: dongle) applications, PTN3381B includes an onboard 5 V DC regulator. Its output is designed to provide the required 5 V power supply to the DVI or HDMI connector, thereby eliminating the need for a separate external regulator. The on-board regulator needs only two external capacitors to operate, and its output is active whenever a valid 3.3 V is applied to the PTN3381B V_{DD} pins.

The low-swing AC-coupled differential input signals to the PTN3381B typically come from a display source with multi-mode I/O, which supports multiple display standards, e.g., DisplayPort, HDMI and DVI. While the input differential signals are configured to carry DVI or HDMI coded data, they do not comply with the electrical requirements of the DVI v1.0 or HDMI v1.3a specification. By using PTN3381B, chip set vendors are able to implement such reconfigurable I/Os on multi-mode display source devices, allowing the support of multiple display standards while keeping the number of chip set I/O pins low. See [Figure 1](#).

The PTN3381B main high-speed differential lanes feature low-swing self-biasing differential inputs which are compliant to the electrical specifications of *DisplayPort Standard v1.1* and/or *PCI Express Standard v1.1*, and open-drain current-steering differential outputs compliant to DVI v1.0 and HDMI v1.3a electrical specifications. The I²C-bus channel actively buffers as well as level-translates the DDC signals for optimal capacitive isolation. Its I²C-bus control block also provides for optional software HDMI dongle detect by issuing a predetermined code sequence upon a read command to an I²C-bus specified address. The PTN3381B also supports power-saving modes in order to minimize current consumption when no display is active or connected.

The PTN3381B is a fully featured HDMI as well as DVI level shifter. It is functionally equivalent to PTN3361B but provides an onboard 5 V regulator.



PTN3381B is powered from a single 3.3 V power supply consuming a small amount of power (100 mW typical without load at 5 V regulator output) and is offered in a 48-terminal HVQFN48 package.

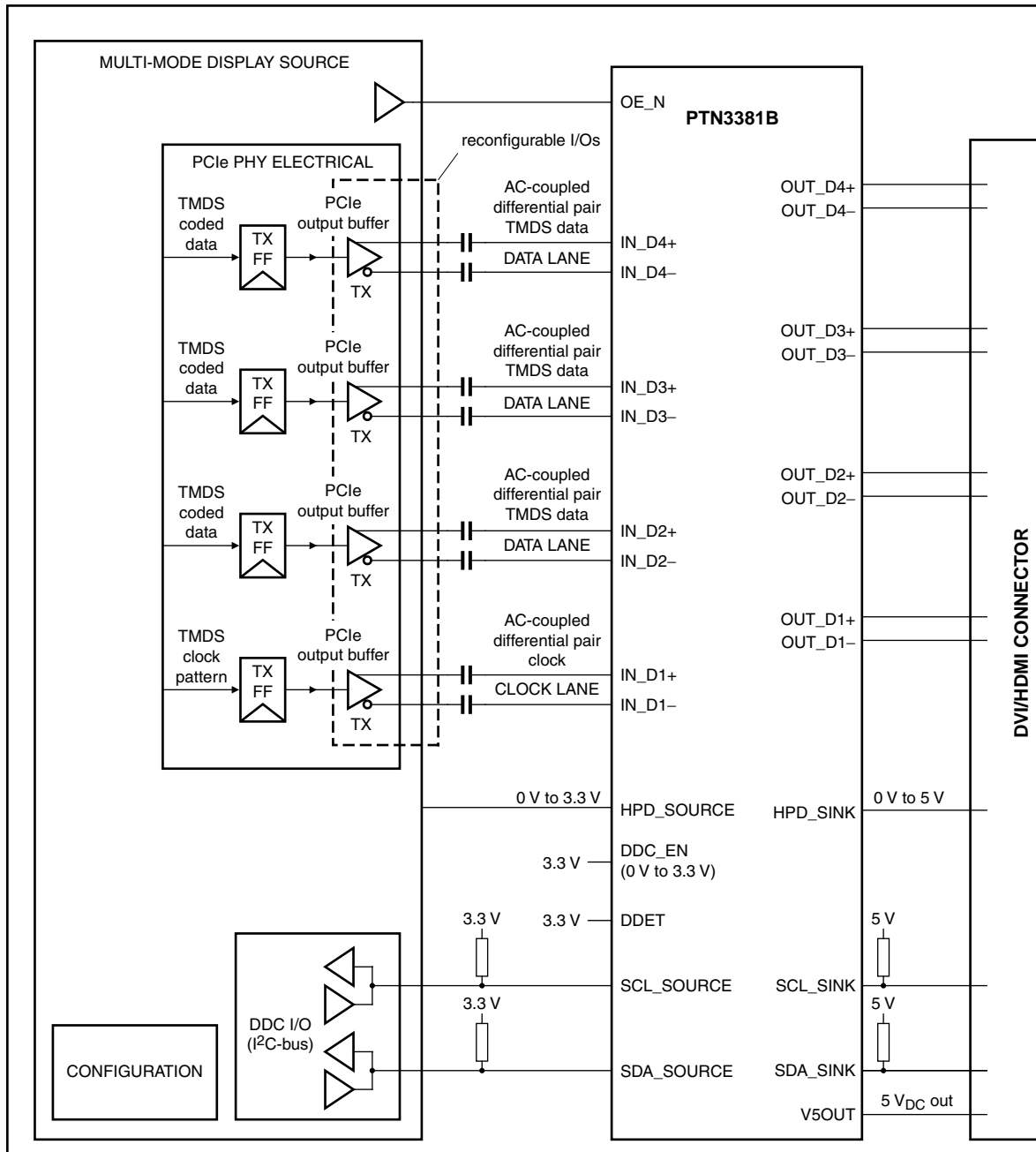

002aae076

Remark: TMDS clock and data lanes can be assigned arbitrarily and interchangeably to D[4:1].

Fig 1. Typical application system diagram

2. Features and benefits

2.1 High-speed TMDS level shifting

- Converts four lanes of low-swing AC-coupled differential input signals to DVI v1.0 and HDMI v1.3a compliant open-drain current-steering differential output signals
- Pin-programmable pre-emphasis feature
- TMDS level shifting operation up to 1.65 Gbit/s per lane (165 MHz character clock)
- TMDS level shifting operation up to 2.25 Gbit/s per lane (225 MHz character clock) using pre-emphasis feature
- Integrated 50 Ω termination resistors for self-biasing differential inputs
- Back-current safe outputs to disallow current when device power is off and monitor is on
- Disable feature to turn off TMDS inputs and outputs and to enter low-power state

2.2 DDC level shifting

- Integrated DDC buffering and level shifting (3.3 V source to 5 V sink side)
- Rise time accelerator on sink-side DDC ports
- 0 Hz to 400 kHz I²C-bus clock frequency
- Back-power safe sink-side terminals to disallow backdrive current when power is off or when DDC is not enabled

2.3 HDMI dongle detect support

- Incorporates I²C slave ROM
- Responds to DDC read to address 81h with predetermined byte sequence
- Feature enabled by pin DDET (must be enabled for correct operation in accordance with DisplayPort interoperability guideline)

2.4 HPD level shifting

- HPD non-inverting level shift from 0 V on the sink side to 0 V on the source side, or from 5 V on the sink side to 3.3 V on the source side
- Integrated 200 k Ω pull-down resistor on HPD sink input guarantees 'input LOW' when no display is plugged in
- Back-power safe design on HPD_SINK to disallow backdrive current when power is off

2.5 5 V DC voltage regulator

- Generates 5 V for the DVI/HDMI connector from the 3.3 V DP_PWR pin supplied by the DisplayPort connector
- Supports up to 75 mA of load current with an accuracy of ± 300 mV
- Only two external capacitors required
- Eliminates need for an external 5 V regulator in dongle applications
- Back drive protection on 5 V output
- Short-circuit protection
- Overcurrent protection

2.6 General

- Power supply $3.3\text{ V} \pm 10\%$
- ESD resilience to 4 kV HBM, 1 kV CDM
- Support for optional HDMI dongle detection via DDC/I²C-bus channel
- Power-saving modes (using output enable)
- Back-current-safe design on all sink-side main link, DDC and HPD terminals
- Transparent operation: no re-timing or software configuration required

3. Applications

- DisplayPort to HDMI adapters
- DisplayPort to DVI adapters required to drive long cables

4. Ordering information

Table 1. Ordering information

| Type number | Package | | Version |
|-------------|---------|---|----------|
| | Name | Description | |
| PTN3381BBS | HVQFN48 | plastic thermal enhanced very thin quad flat package; no leads; 48 terminals; body $7 \times 7 \times 0.85\text{ mm}$ | SOT619-1 |

5. Functional diagram

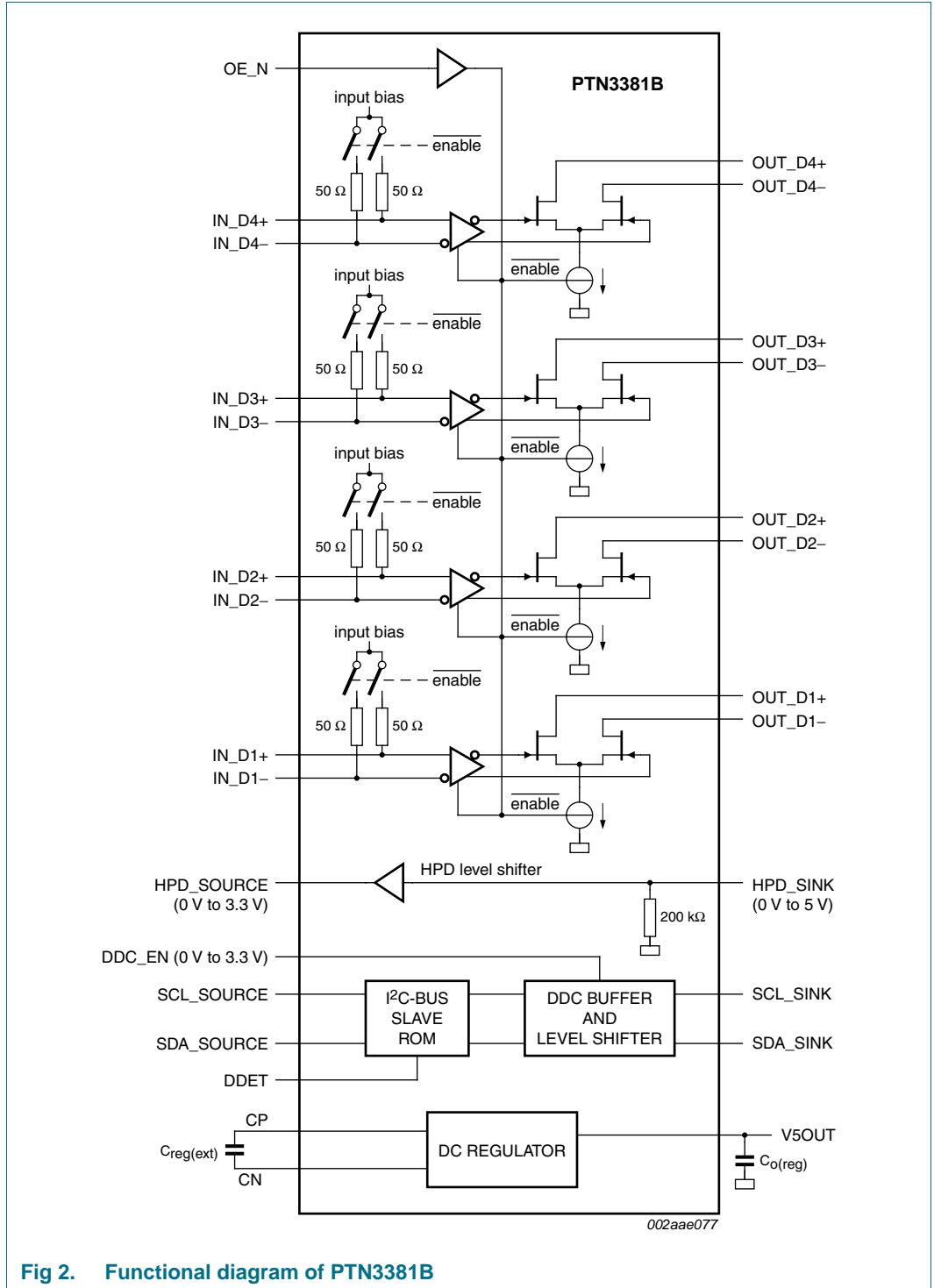
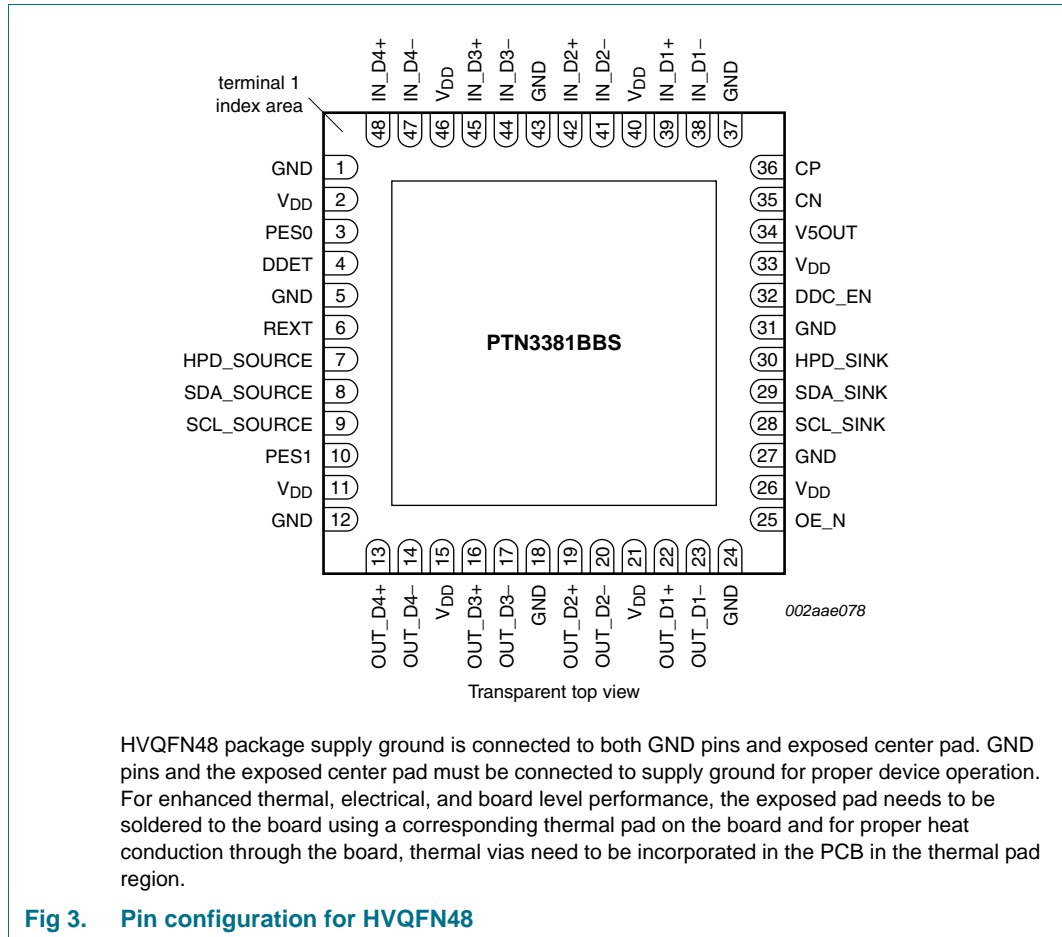

Fig 2. Functional diagram of PTN3381B

6. Pinning information

6.1 Pinning



6.2 Pin description

Table 2. Pin description

| Symbol | Pin | Type | Description |
|---------------------------------------|-----|---|---|
| OE_N, IN_Dx and OUT_Dx signals | | | |
| OE_N | 25 | 3.3 V low-voltage CMOS single-ended input | Output Enable and power saving function for high-speed differential level shifter path. When OE_N = HIGH: IN_Dx termination = high-impedance OUT_Dx outputs = high-impedance; zero output current When OE_N = LOW: IN_Dx termination = 50 Ω OUT_Dx outputs = active |
| IN_D4+ | 48 | Self-biasing differential input | Low-swing differential input from display source with PCI Express electrical signalling. IN_D4+ makes a differential pair with IN_D4-. The input to this pin must be AC coupled externally. |

Table 2. Pin description ...continued

| Symbol | Pin | Type | Description |
|----------------------------|-----|---------------------------------------|---|
| IN_D4- | 47 | Self-biasing differential input | Low-swing differential input from display source with PCI Express electrical signalling. IN_D4- makes a differential pair with IN_D4+. The input to this pin must be AC coupled externally. |
| IN_D3+ | 45 | Self-biasing differential input | Low-swing differential input from display source with PCI Express electrical signalling. IN_D3+ makes a differential pair with IN_D3-. The input to this pin must be AC coupled externally. |
| IN_D3- | 44 | Self-biasing differential input | Low-swing differential input from display source with PCI Express electrical signalling. IN_D3- makes a differential pair with IN_D3+. The input to this pin must be AC coupled externally. |
| IN_D2+ | 42 | Self-biasing differential input | Low-swing differential input from display source with PCI Express electrical signalling. IN_D2+ makes a differential pair with IN_D2-. The input to this pin must be AC coupled externally. |
| IN_D2- | 41 | Self-biasing differential input | Low-swing differential input from display source with PCI Express electrical signalling. IN_D2- makes a differential pair with IN_D2+. The input to this pin must be AC coupled externally. |
| IN_D1+ | 39 | Self-biasing differential input | Low-swing differential input from display source with PCI Express electrical signalling. IN_D1+ makes a differential pair with IN_D1-. The input to this pin must be AC coupled externally. |
| IN_D1- | 38 | Self-biasing differential input | Low-swing differential input from display source with PCI Express electrical signalling. IN_D1- makes a differential pair with IN_D1+. The input to this pin must be AC coupled externally. |
| OUT_D4+ | 13 | TMDS differential output | HDMI compliant TMDS output. OUT_D4+ makes a differential pair with OUT_D4-. OUT_D4+ is in phase with IN_D4+. |
| OUT_D4- | 14 | TMDS differential output | HDMI compliant TMDS output. OUT_D4- makes a differential pair with OUT_D4+. OUT_D4- is in phase with IN_D4-. |
| OUT_D3+ | 16 | TMDS differential output | HDMI compliant TMDS output. OUT_D3+ makes a differential pair with OUT_D3-. OUT_D3+ is in phase with IN_D3+. |
| OUT_D3- | 17 | TMDS differential output | HDMI compliant TMDS output. OUT_D3- makes a differential pair with OUT_D3+. OUT_D3- is in phase with IN_D3-. |
| OUT_D2+ | 19 | TMDS differential output | HDMI compliant TMDS output. OUT_D2+ makes a differential pair with OUT_D2-. OUT_D2+ is in phase with IN_D2+. |
| OUT_D2- | 20 | TMDS differential output | HDMI compliant TMDS output. OUT_D2- makes a differential pair with OUT_D2+. OUT_D2- is in phase with IN_D2-. |
| OUT_D1+ | 22 | TMDS differential output | HDMI compliant TMDS output. OUT_D1+ makes a differential pair with OUT_D1-. OUT_D1+ is in phase with IN_D1+. |
| OUT_D1- | 23 | TMDS differential output | HDMI compliant TMDS output. OUT_D1- makes a differential pair with OUT_D1+. OUT_D1- is in phase with IN_D1-. |
| HPD and DDC signals | | | |
| HPD_SINK | 30 | 5 V CMOS single-ended input | 0 V to 5 V (nominal) input signal. This signal comes from the DVI or HDMI sink. A HIGH value indicates that the sink is connected; a LOW value indicates that the sink is disconnected. HPD_SINK is pulled down by an integrated 200 kΩ pull-down resistor. |
| HPD_SOURCE | 7 | 3.3 V CMOS single-ended output | 0 V to 3.3 V (nominal) output signal. This is level-shifted version of the HPD_SINK signal. |
| SCL_SOURCE | 9 | single-ended 3.3 V open-drain DDC I/O | 3.3 V source-side DDC clock I/O. Pulled up by external termination to 3.3 V. |
| SDA_SOURCE | 8 | single-ended 3.3 V open-drain DDC I/O | 3.3 V source-side DDC data I/O. Pulled up by external termination to 3.3 V. |

Table 2. Pin description ...continued

| Symbol | Pin | Type | Description |
|----------|-----|-------------------------------------|--|
| SCL_SINK | 28 | single-ended 5 V open-drain DDC I/O | 5 V sink-side DDC clock I/O. Pulled up by external termination to 5 V. Provides rise time acceleration for LOW-to-HIGH transitions. |
| SDA_SINK | 29 | single-ended 5 V open-drain DDC I/O | 5 V sink-side DDC data I/O. Pulled up by external termination to 5 V. Provides rise time acceleration for LOW-to-HIGH transitions. |
| DDC_EN | 32 | 3.3 V CMOS input | Enables the DDC buffer and level shifter. When DDC_EN = LOW, buffer/level shifter is disabled. When DDC_EN = HIGH, buffer and level shifter are enabled. |

Supply and ground

| | | | |
|--------------------|----------------------------------|-----------------|---|
| V _{DD} | 2, 11, 15, 21, 26, 33, 40, 46 | 3.3 V DC supply | Supply voltage; 3.3 V ± 10 %. |
| GND ^[1] | 1, 5, 12, 18, 24, 27, 31, 37, 43 | ground | Supply ground. All GND pins must be connected to ground for proper operation. |

Feature control signals

| | | | |
|------|----|------------------|--|
| REXT | 6 | analog I/O | Current sense port used to provide an accurate current reference for the differential outputs OUT_Dx. For best output voltage swing accuracy, use of a 10 kΩ resistor (1 % tolerance) from this terminal to GND is recommended. May also be left open-circuit or tied to either V _{DD} or GND. See Section 7.2 for details. |
| DDET | 4 | 3.3 V input | Dongle detect enable input. When HIGH, the dongle detect function via I ² C is active. When LOW, the dongle detect function will not respond to an I ² C-bus command. Must be tied to GND or V _{DD} either directly or via a resistor. Note that this pin may not be left open-circuit. When used in an HDMI dongle, this pin must be tied HIGH for correct operation in accordance with DisplayPort interoperability guidelines. When used in a DVI dongle, this pin must be tied LOW. |
| PES1 | 10 | 3.3 V CMOS input | Programming pins to activate the pre-emphasis feature of the TMDS differential outputs. See Section 7.3 for details. Must be tied either to GND or V _{DD} either directly or via a resistor (< 1 kΩ). To disable pre-emphasis, connect both to GND (PES[1:0] = 00b). PES[1:0] = 11b is reserved for testing purposes and should not be used in normal application. Note that these pins may not be left open-circuit. |
| PES0 | 3 | 3.3 V CMOS input | |

Voltage regulator terminals

| | | | |
|-------|----|---------------------|--|
| CP | 36 | analog high-voltage | Positive terminal for the voltage regulator external capacitor. ^[2] |
| CN | 35 | analog high-voltage | Negative terminal for the voltage regulator external capacitor. ^[2] |
| V5OUT | 34 | power output | 5 V regulated output from the integrated voltage regulator. ^[2] |

[1] HVQFN48 package supply ground is connected to both GND pins and exposed center pad. GND pins and the exposed center pad must be connected to supply ground for proper device operation. For enhanced thermal, electrical, and board level performance, the exposed pad needs to be soldered to the board using a corresponding thermal pad on the board and for proper heat conduction through the board, thermal vias need to be incorporated in the PCB in the thermal pad region.

[2] A ceramic capacitor with ESR < 100 mΩ is recommended and should be placed close to the pin(s).

7. Functional description

Refer to [Figure 2 “Functional diagram of PTN3381B”](#).

The PTN3381B level shifts four lanes of low-swing AC-coupled differential input signals to DVI and HDMI compliant open-drain current-steering differential output signals, up to 1.65 Gbit/s per lane. Speed of operation and cable length drive may be extended (by using the programmable pre-emphasis feature) to up to 2.25 Gbit/s per lane. It has integrated 50 Ω termination resistors for AC-coupled differential input signals. An enable signal OE_N can be used to turn off the TMDS inputs and outputs, thereby minimizing power consumption. The TMDS outputs are back-power safe to disallow current flow from a powered sink while the PTN3381B is unpowered.

The PTN3381B's DDC channel provides active level shifting and buffering, allowing 3.3 V source-side termination and 5 V sink-side termination. The sink-side DDC ports are equipped with a rise time accelerator enabling drive of long cables or high bus capacitance. This enables the system designer to isolate bus capacitance to meet HDMI DDC version 1.3a distance specification. Furthermore, the DDC channel is augmented with an I²C-bus slave ROM device that provides optional HDMI dongle detect response, which can be enabled by dongle detect signal DDET. The PTN3381B offers back-power safe sink-side I/Os to disallow backdrive current from the DDC clock and data lines when power is off or when DDC is not enabled. An enable signal DCC_EN enables the DDC level shifter block.

Remark: When used in an HDMI dongle, the DDET function **must** be enabled for correct operation in accordance with DisplayPort interoperability guidelines. When used in a DVI dongle, the DDET function **must** be disabled.

The PTN3381B also provides voltage translation for the Hot Plug Detect (HPD) signal from 0 V to 5 V on the sink side to 0 V to 3.3 V on the source side.

PTN3381B includes an onboard 5 V DC regulator, designed to provide the required 5 V power supply to the DVI or HDMI connector, thereby eliminating the need for a separate external regulator. The onboard regulator needs only two external capacitors to operate, and its output is active whenever a valid 3.3 V is applied to the PTN3381B V_{DD} pins. The back drive protection on 5 V output prevents back-drive current from 5 V output to the input supply. The short-circuit protection limits current flowing through the supply, and the overcurrent protection prevents overload conditions at the charge pump output.

The PTN3381B does not re-time any data. It contains no state machines except for the DDC/I²C-bus block. No inputs or outputs of the device are latched or clocked. Because the PTN3381B acts as a transparent level shifter, no reset is required.

7.1 Enable and disable features

PTN3381B offers different ways to enable or disable functionality, using the Output Enable (OE_N), and DDC Enable (DDC_EN) inputs. Whenever the PTN3381B is disabled, the device will be in standby mode and power consumption will be minimal; otherwise the PTN3381B will be in active mode and power consumption will be nominal. These two inputs each affect the operation of PTN3381B differently: OE_N controls the TMDS channels, DDC_EN affects only the DDC channel, and HPD_SINK does not affect either of the channels. The following sections and truth table describe their detailed operation.

7.1.1 Hot plug detect

The HPD channel of PTN3381B functions as a level-shifting buffer to pass the HPD logic signal from the display sink device (via input HPD_SINK) on to the display source device (via output HPD_SOURCE).

The output logic state of HPD_SOURCE output always follows the logic state of input HPD_SINK, regardless of whether the device is in active or standby mode.

7.1.2 Output Enable function (OE_N)

When input OE_N is asserted (active LOW), the IN_Dx and OUT_Dx signals are fully functional. Input termination resistors are enabled and the internal bias circuits are turned on.

When OE_N is de-asserted (inactive HIGH), the OUT_Dx outputs are in a high-impedance state and drive zero output current. The IN_Dx input buffers are disabled and IN_Dx termination is disabled. Power consumption is minimized.

Remark: Note that OE_N signal level has no influence on the HPD_SINK input, HPD_SOURCE output, or the SCL and SDA level shifters. A transition from HIGH to LOW at OE_N may disable the DDC channel for up to 20 μ s.

7.1.3 DDC channel enable function (DDC_EN)

The DDC_EN pin is active HIGH and can be used to isolate a badly behaved slave. When DDC_EN is LOW, the DDC channel is turned off. The DDC_EN input should never change state during an I²C-bus operation. Note that disabling DDC_EN during a bus operation may hang the bus, while enabling DDC_EN during bus traffic would corrupt the I²C-bus operation. Hence, DDC_EN should only be toggled while the bus is idle. (See I²C-bus specification).

7.1.4 Enable/disable truth table

Table 3. HPD_SINK, OE_N and DDC_EN enabling truth table

| Inputs | | | Channels | | | | Mode |
|----------|-------------|---------------|---|-------------------------------------|---|---------------|----------------------|
| HPD_SINK | OE_N [1] | DDC_EN [2] | IN_Dx | OUT_Dx[3] | DDC[4] | HPD_SOURCE[5] | |
| LOW | LOW | LOW | 50 Ω termination to $V_{RX(bias)}$ | enabled | high-impedance | LOW | Active; DDC disabled |
| LOW | LOW | HIGH | 50 Ω termination to $V_{RX(bias)}$ | enabled | SDA_SINK connected to SDA_SOURCE and SCL_SINK connected to SCL_SOURCE | LOW | Active; DDC enabled |
| LOW | HIGH | LOW | high-impedance | high-impedance; zero output current | high-impedance | LOW | Standby |
| LOW | HIGH | HIGH | high-impedance | high-impedance; zero output current | SDA_SINK connected to SDA_SOURCE and SCL_SINK connected to SCL_SOURCE | LOW | Standby; DDC enabled |
| HIGH | LOW | LOW | 50 Ω termination to $V_{RX(bias)}$ | enabled | high-impedance | HIGH | Active; DDC disabled |
| HIGH | LOW | HIGH | 50 Ω termination to $V_{RX(bias)}$ | enabled | SDA_SINK connected to SDA_SOURCE and SCL_SINK connected to SCL_SOURCE | HIGH | Active; DDC enabled |
| HIGH | HIGH | LOW | high-impedance | high-impedance; zero output current | high-impedance | HIGH | Standby |
| HIGH | HIGH | HIGH | high-impedance | high-impedance; zero output current | SDA_SINK connected to SDA_SOURCE and SCL_SINK connected to SCL_SOURCE | HIGH | Standby; DDC enabled |

[1] A HIGH level on input OE_N disables only the TMDS channels.

[2] A LOW level on input DDC_EN disables only the DDC channel.

[3] OUT_Dx channels 'enabled' means outputs OUT_Dx toggling in accordance with IN_Dx differential input voltage switching.

[4] DDC channel 'enabled' means SDA_SINK is connected to SDA_SOURCE and SCL_SINK is connected to SCL_SOURCE.

[5] The HPD_SOURCE output logic state always follows the HPD_SINK input logic state.

7.2 Analog current reference

The REXT pin (pin 6) is an analog current sense port used to provide an accurate current reference for the differential outputs OUT_Dx. For best output voltage swing accuracy, use of a 10 kΩ resistor (1 % tolerance) connected between this terminal and GND is recommended.

If an external 10 kΩ ± 1 % resistor is not used, this pin can be left open-circuit, or connected to GND or V_{DD}, either directly (0 Ω) or using pull-up or pull-down resistors of value less than 10 kΩ. In any of these cases, the output will function normally but at reduced accuracy over voltage and temperature of the following parameters: output levels (V_{OL}), differential output voltage swing, and rise and fall time accuracy.

7.3 Programmable pre-emphasis

PTN3381B includes an optional programmable pre-emphasis feature, allowing adaptor or motherboard PCB designers to extend speed performance or support longer cable drive. The pre-emphasis feature, when enabled, adds a selectable amount of pre-emphasis to each bit transition by injecting a momentary current pulse (typically 200 ps to 400 ps long) to help overcome cable or trace losses.

Pre-emphasis is not needed for normal HDMI operation at speeds below 1.65 Gbit/s and is not required to meet eye diagram compliance. At the user's discretion, it can be enabled in order to provide additional signal boost in difficult or lossy signaling environments such as long cables or lossy media.

It should be noted that by enabling pre-emphasis, in addition to the AC effect of the pre-emphasis pulse on the signal transition, also a constant DC current is added in order to provide the necessary headroom, which will affect V_{OH} and V_{OL} static levels. This should be taken into account when designing for HDMI or DVI single-ended (DC) voltage compliance. For full HDMI or DVI compliance in normal applications, the default mode (pre-emphasis off) is recommended.

The pre-emphasis feature is programmed by means of two CMOS input pins, PES1 and PES0, according to [Table 4](#):

Table 4. PTN3381B pre-emphasis logic table

| PES1 (pin 10) | PES0 (pin 3) | Level |
|---------------|--------------|--------------------------|
| 0 | 0 | 0 dB (default) |
| 0 | 1 | 3.5 dB (150 %) |
| 1 | 0 | 6 dB (200 %) |
| 1 | 1 | Test mode ^[1] |

[1] Should not be used in normal application.

7.4 Backdrive current protection

The PTN3381B is designed for backdrive prevention on all sink-side TMDS outputs, sink-side DDC I/Os and the HPD_SINK input. This supports user scenarios where the display is connected and powered, but the PTN3381B is unpowered. In these cases, the PTN3381B will sink no more than a negligible amount of leakage current, and will block the display (sink) termination network from driving the power supply of the PTN3381B or that of the inactive DVI or HDMI source.

7.5 Active DDC buffer with rise time accelerator

The PTN3381B DDC channel, besides providing 3.3 V to 5 V level shifting, includes active buffering and rise time acceleration which allows up to 18 meters bus extension for reliable DDC applications. While retaining all the operating modes and features of the I²C-bus system during the level shifts, it permits extension of the I²C-bus by providing bidirectional buffering for both the data (SDA) and the clock (SCL) line as well as the rise time accelerator on the sink-side port (SCL_SINK and SDA_SINK) enabling the bus to drive a load up to 1400 pF or distance of 18 m on the sink-side port, and 400 pF on the source-side port (SCL_SOURCE and SCA_SOURCE). Using the PTN3381B for DVI or HDMI level shifting enables the system designer to isolate bus capacitance to meet HDMI DDC version 1.3 distance specification. The SDA and SCL pins are overvoltage tolerant and are high-impedance when the PTN3381B is unpowered or when DDC_EN is LOW.

PTN3381B has rise time accelerators on the sink-side port (SCL_SINK and SDA_SINK) only. During positive bus transitions on the sink-side port, a current source is switched on to quickly slew the SCL_SINK and SDA_SINK lines HIGH once the 5 V DDC bus V_{IL} threshold level of around 1.5 V is exceeded, and turns off as the 5 V DDC bus V_{IH} threshold voltage of approximately 3.5 V is approached.

7.6 I²C-bus based HDMI dongle detection

The PTN3381B includes an on-board I²C-bus slave ROM which provides a means to detect the presence of an HDMI dongle by the system through the DDC channel, accessible via ports SDA_SOURCE and SCL_SOURCE. This allows system vendors to detect HDMI dongle presence through the already available DDC/I²C-bus port using a predetermined bus sequence. Please see [Section 8](#) for more information.

For the I²C-bus HDMI Dongle Detect function to be active, input pin DDET (dongle detect) should be tied HIGH. When DDET is LOW, the PTN3381B will not respond to an I²C-bus command. When used in an HDMI dongle, the DDET function **must** be enabled for correct operation in accordance with DisplayPort interoperability guidelines. When used in a DVI dongle, the DDET function **must** be disabled.

The HDMI dongle detection is accomplished by accessing the PTN3381B on-board I²C-bus slave ROM using a simple sequential I²C-bus Read operation as described below.

7.6.1 Slave address



7.6.2 Read operation

The slave device address of PTN3381B is 80h. PTN3381B will respond to a Read command to slave address 81h (PTN3381B will respond with an ACK to a Write command to address 80h). Following the Read command, the PTN3381B will respond with the contents of its internal ROM, as a sequence of 16 bytes, for as long as the master continues to issue clock edges with an acknowledge after each byte. The 16-byte sequence represents the 'DP-HDMI ADAPTOR<EOT>' symbol converted to ASCII and is documented in [Table 5](#).

The PTN3381B auto-increments its internal ROM address pointer (0h through Fh) as long as it continues to receive clock edges from the master with an acknowledge after each byte. If the master continues to issue clock edges past the 16th byte, the PTN3381B will respond with a data byte of FFh. If the master does not acknowledge a received byte, the PTN3381B internal address pointer will be reset to 0 and a new Read sequence should be started by the master. Access to the 16-byte is by sequential read only as described above; there is no random-access possible to any specific byte in the ROM.

Table 5. DisplayPort - HDMI Adaptor Detection ROM content

| Internal pointer offset (hex) | 0 | 1 | 2 | 3 | 4 | 5 | 6 | 7 | 8 | 9 | A | B | C | D | E | F |
|-------------------------------|----|----|----|----|----|----|----|----|----|----|----|----|----|----|----|----|
| Data (hex) | 44 | 50 | 2D | 48 | 44 | 4D | 49 | 20 | 41 | 44 | 41 | 50 | 54 | 4F | 52 | 04 |

Table 6. HDMI dongle detect transaction sequence outline

| Phase | I ² C transaction | Transmitting | Bit | | | | | | | | Status | | |
|-------|------------------------------|--------------|-------------------------------|---|---|---|---|---|---|-----|-----------|-----------|---|
| | | | 7 | 6 | 5 | 4 | 3 | 2 | 1 | R/W | Master | Slave | |
| 1 | START | master | | | | | | | | | optional | - | |
| 2 | Write command | master | 1 | 0 | 0 | 0 | 0 | 0 | 0 | 0 | 0 | optional | - |
| 3 | Acknowledge | slave | | | | | | | | | - | mandatory | |
| 4 | Word address offset | master | word address offset data byte | | | | | | | | optional | - | |
| 5 | Acknowledge | slave | | | | | | | | | - | mandatory | |
| 6 | STOP | master | | | | | | | | | optional | - | |
| 7 | START | master | | | | | | | | | mandatory | - | |
| 8 | Read command | master | 1 | 0 | 0 | 0 | 0 | 0 | 0 | 0 | 1 | mandatory | - |
| 9 | Acknowledge | slave | | | | | | | | | - | mandatory | |
| 10 | Read data | slave | data byte at offset 0 | | | | | | | | - | mandatory | |
| 11 | Acknowledge | master | | | | | | | | | mandatory | - | |
| 12 | Read data | slave | data byte at offset 1 | | | | | | | | - | mandatory | |
| 13 | : | : | | | | | | | | | - | - | |
| : | : | : | | | | | | | | | - | - | |
| 40 | Read data | slave | data byte at offset 15 | | | | | | | | - | mandatory | |
| 41 | Not Acknowledge | master | | | | | | | | | mandatory | - | |
| 42 | STOP | master | | | | | | | | | mandatory | - | |

Remark: If the slave does not acknowledge the above transaction sequence, the entire sequence should be retried by the source.

7.7 Characteristics of the I²C-bus

The I²C-bus is for 2-way, 2-line communication between different ICs or modules. The two lines are a Serial Data line (SDA) and a Serial Clock Line (SCL). Both lines must be connected to a positive supply via a pull-up resistor when connected to the output stages of a device. Data transfer may be initiated only when the bus is not busy.

7.7.1 Bit transfer

One data bit is transferred during each clock phase. The data on the SDA line must remain stable during the HIGH period of the clock pulse as changes in the data line at this time will be interpreted as control signals (see [Figure 5](#)).

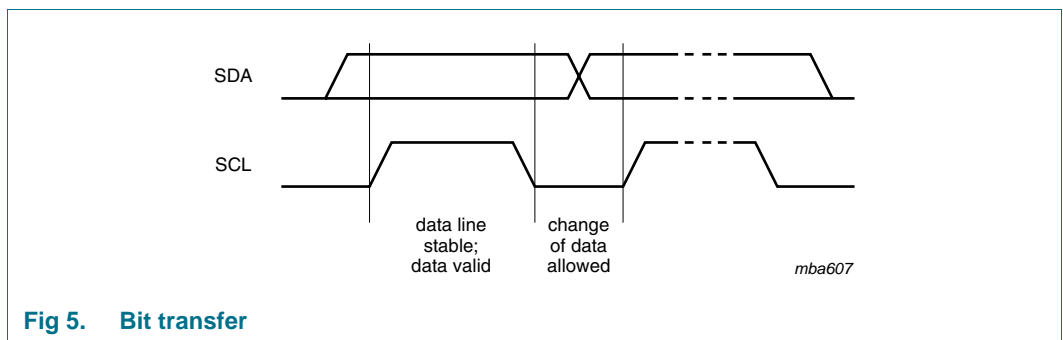

Fig 5. Bit transfer

7.7.2 START and STOP conditions

Both data and clock lines remain HIGH when the bus is not busy. A HIGH-to-LOW transition of the data line, while the clock is HIGH is defined as the START condition (S). A LOW-to-HIGH transition of the data line while the clock is HIGH is defined as the STOP condition (P). See [Figure 6](#).

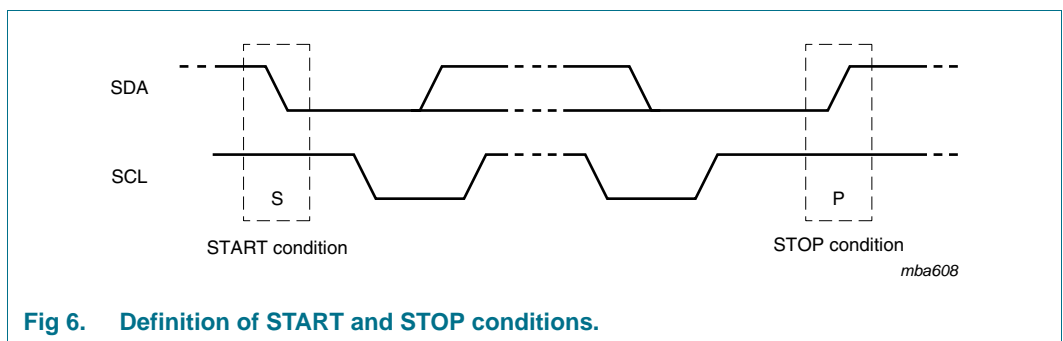

Fig 6. Definition of START and STOP conditions.

7.7.3 System configuration

An I²C-bus device generating a message is a 'transmitter', a device receiving is the 'receiver'. The device that controls the message is the 'master' and the devices which are controlled by the master are the 'slaves'. See [Figure 7](#).

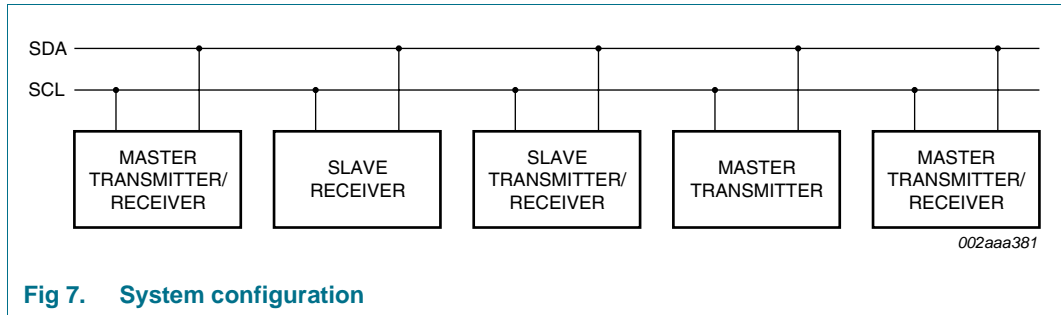

Fig 7. System configuration

7.7.4 Acknowledge

The number of data bytes transferred between the START and the STOP conditions from transmitter to receiver is not limited. Each byte of eight bits is followed by one acknowledge bit. The acknowledge bit is a HIGH level put on the bus by the transmitter, whereas the master generates an extra acknowledge related clock pulse.

A slave receiver which is addressed must generate an acknowledge after the reception of each byte. Also, a master must generate an acknowledge after the reception of each byte that has been clocked out of the slave transmitter. The device that acknowledges has to pull down the SDA line during the acknowledge clock pulse so that the SDA line is stable LOW during the HIGH period of the acknowledge related clock pulse, set-up and hold times must be taken into account.

A master receiver must signal an end of data to the transmitter by not generating an acknowledge on the last byte that has been clocked out of the slave. In this event, the transmitter must leave the data line HIGH to enable the master to generate a STOP condition.

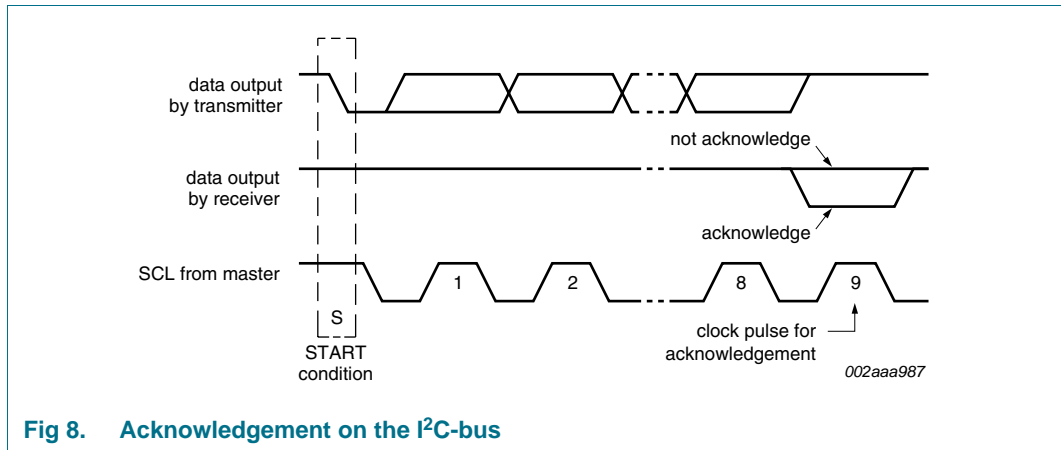

Fig 8. Acknowledgement on the I²C-bus

8. Application design-in information

8.1 Dongle or cable adaptor detect discovery mechanism

The PTN3381B supports the source-side dongle detect discovery mechanism described in *VESA DisplayPort Interoperability Guideline Version 1.1*.

When a source-side cable adaptor is plugged into a multi-mode source device that supports multiple standards such as DisplayPort, DVI and HDMI, a discovery mechanism is needed for the multi-mode source to configure itself for outputting DisplayPort, DVI or HDMI compliant signals through the dongle or cable adaptor. The discovery mechanism ensures that a multi-mode source device only sends either DVI or HDMI signals when a valid DVI or HDMI cable adaptor is present.

The *VESA Interoperability Guideline* recommends that a multi-mode source to power up with both DDC and AUX CH disabled. After initialization, the source device can use a variety of mechanisms to decide whether a dongle or cable adaptor is present by detecting pin 13 on the DisplayPort connector. Depending on the voltage level detected at pin 13, the source configures itself either:

- as a DVI or HDMI source (see below paragraph for detection between DVI and HDMI), and enables DDC, while keeping AUX CH disabled, **or**
- as a DisplayPort source and enables AUX CH, while keeping DDC disabled.

The monitoring of the voltage level on pin 13 by a multi-mode source device is optional. A multi-mode source may also e.g. attempt an AUX CH read transaction and, if the transaction fails, a DDC transaction to discover the presence/absence of a cable adaptor.

Furthermore, a source that supports both DVI and HDMI can discover whether a DVI or HDMI dongle or cable adaptor is present by using a variety of discovery procedures. One possible method is to check the voltage level of pin 14 of the DisplayPort connector. Pin 14 also carries CEC signal used for HDMI. Please note that other HDMI devices on the CEC line may be momentarily pulling down pin 14 as a part of CEC protocol.

The *VESA Interoperability Guideline* recommends that a multi-mode source should distinguish a source-side HDMI cable adaptor from a DVI cable adaptor by checking the DDC buffer ID as described in [Section 7.6 “I²C-bus based HDMI dongle detection”](#). While it is optional for a multi-mode source to use the I²C-bus based HDMI dongle detection mechanism, it is mandatory for HDMI dongle or cable adaptor to respond to the I²C-bus read command described in [Section 7.7](#). The PTN3381B provides an integrated I²C-bus slave ROM to support this mandatory HDMI dongle detect mechanism for HDMI dongles.

For a DisplayPort-to-HDMI source-side dongle or cable adaptor, DDET must be tied HIGH to enable the I²C-based HDMI dongle detection response function of PTN3381B. For a DisplayPort-to-DVI sink-side dongle or cable adaptor, DDET must be tied LOW to disable the function.

9. Limiting values

Table 7. Limiting values

In accordance with the Absolute Maximum Rating System (IEC 60134).

| Symbol | Parameter | Conditions | Min | Max | Unit |
|------------------|---------------------------------|----------------------|-------|-----------------------|------|
| V _{DD} | supply voltage | (3.3 V) | -0.3 | +4.6 | V |
| V _I | input voltage | 3.3 V CMOS inputs | -0.3 | V _{DD} + 0.5 | V |
| | | 5.0 V CMOS inputs | -0.3 | 6.0 | V |
| R _L | load resistance | 5 V regulator output | 25 | - | Ω |
| T _{stg} | storage temperature | | -65 | +150 | °C |
| V _{ESD} | electrostatic discharge voltage | HBM | [1] - | 4000 | V |
| | | CDM | [2] - | 1000 | V |

[1] Human Body Model: ANSI/EOS/ESD-S5.1-1994, standard for ESD sensitivity testing, Human Body Model - Component level; Electrostatic Discharge Association, Rome, NY, USA.

[2] Charged Device Model: ANSI/EOS/ESD-S5.3-1-1999, standard for ESD sensitivity testing, Charged Device Model - Component level; Electrostatic Discharge Association, Rome, NY, USA.

10. Recommended operating conditions

Table 8. Recommended operating conditions

| Symbol | Parameter | Conditions | Min | Typ | Max | Unit |
|-----------------------|--------------------------------|--|-------|----------|-----|------|
| V _{DD} | supply voltage | | 3.0 | 3.3 | 3.6 | V |
| V _I | input voltage | 3.3 V CMOS inputs | 0 | - | 3.6 | V |
| | | 5.0 V CMOS inputs | 0 | - | 5.5 | V |
| V _{I(AV)} | average input voltage | IN_Dn+, IN_Dn- inputs | [1] - | 0 | - | V |
| R _{ref(ext)} | external reference resistance | connected between pin REXT (pin 6) and GND | [2] - | 10 ± 1 % | - | kΩ |
| I _{load} | load current | 5 V regulator output | - | - | 75 | mA |
| C _{o(reg)} | regulator output capacitance | external capacitor on pin V5OUT | [3] - | 1 | - | μF |
| C _{reg(ext)} | external regulator capacitance | from pin CP to pin CN | [3] - | 330 | - | nF |
| T _{amb} | ambient temperature | operating in free air | -40 | - | +85 | °C |

[1] Input signals to these pins must be AC-coupled.

[2] Operation without external reference resistor is possible but will result in reduced output voltage swing accuracy. For details, see [Section 7.2](#).

[3] A ceramic capacitor with ESR < 100 mΩ is recommended and should be placed close to the pin(s).

10.1 Current consumption

Table 9. Current consumption

| Symbol | Parameter | Conditions | Min | Typ | Max | Unit |
|-----------------|----------------|--|-----|-----|-----|------|
| I _{DD} | supply current | OE_N = 0; Active mode | | | | |
| | | no load | 10 | 30 | 50 | mA |
| | | with 75 mA load | - | 200 | 300 | mA |
| | | OE_N = 1 and DDC_EN = 0; Standby mode; no load | - | - | 5 | mA |

11. Characteristics

11.1 Differential inputs

Table 10. Differential input characteristics for IN_Dx signals

| Symbol | Parameter | Conditions | Min | Typ | Max | Unit |
|-------------------------|---|---------------------------------------|----------------------|-----|-------|------|
| UI | unit interval ^[1] | | ^[2] 600 | - | 4000 | ps |
| V _{RX_DIFFp-p} | differential input peak-to-peak voltage | | ^[3] 0.175 | - | 1.200 | V |
| T _{RX_EYE} | receiver eye time | minimum eye width at IN_Dx input pair | 0.8 | - | - | UI |
| V _{i(cm)M(AC)} | peak common-mode input voltage (AC) | includes all frequencies above 30 kHz | ^[4] - | - | 100 | mV |
| Z _{RX_DC} | DC input impedance | | 40 | 50 | 60 | Ω |
| V _{RX(bias)} | bias receiver voltage | | ^[5] 1.0 | 1.2 | 1.4 | V |
| Z _{I(se)} | single-ended input impedance | inputs in high-impedance state | ^[6] 100 | - | - | kΩ |

[1] UI (unit interval) = t_{bit} (bit time).

[2] UI is determined by the display mode. Nominal bit rate ranges from 250 Mbit/s to 1.65 Gbit/s per lane. Nominal UI at 1.65 Gbit/s = 606 ps.

[3] V_{RX_DIFFp-p} = 2 × |V_{RX_D+} - V_{RX_D-}|. Applies to IN_Dx signals.

[4] V_{i(cm)M(AC)} = |V_{RX_D+} + V_{RX_D-}| / 2 - V_{RX(cm)}.
V_{RX(cm)} = DC (avg) of |V_{RX_D+} + V_{RX_D-}| / 2.

[5] Intended to limit power-up stress on chip set's PCIe output buffers.

[6] Differential inputs will switch to a high-impedance state when OE_N is HIGH.

11.2 Differential outputs

The level shifter's differential outputs are designed to meet HDMI version 1.3 and DVI version 1.0 specifications.

Table 11. Differential output characteristics for OUT_Dx signals

| Symbol | Parameter | Conditions | Min | Typ | Max | Unit |
|--------------------|--|--|---------------------|-----------------|-----------------|---------|
| $V_{OH(se)}$ | single-ended HIGH-level output voltage | PES[1:0] = 00b | [1] $V_{TT} - 0.01$ | V_{TT} | $V_{TT} + 0.01$ | V |
| $V_{OL(se)}$ | single-ended LOW-level output voltage | PES[1:0] = 00b | [2] $V_{TT} - 0.60$ | $V_{TT} - 0.50$ | $V_{TT} - 0.40$ | V |
| $\Delta V_{O(se)}$ | single-ended output voltage variation | logic 1 and logic 0 state applied respectively to differential inputs IN_Dn; $R_{ref(ext)}$ connected; see Table 8 | [3] 400 | 500 | 600 | mV |
| I_{OZ} | OFF-state output current | single-ended | - | - | 10 | μ A |
| t_r | rise time | 20 % to 80 % | 75 | - | 180 | ps |
| t_f | fall time | 80 % to 20 % | 75 | - | 180 | ps |
| t_{sk} | skew time | intra-pair | [4] - | - | 10 | ps |
| | | inter-pair | [5] - | - | 250 | ps |
| t_{jit} | jitter time | jitter contribution | [6] - | - | 10 | ps |

- [1] V_{TT} is the DC termination voltage in the HDMI or DVI sink. V_{TT} is nominally 3.3 V.
- [2] The open-drain output pulls down from V_{TT} .
- [3] Swing down from TMDS termination voltage ($3.3\text{ V} \pm 10\%$).
- [4] This differential skew budget is in addition to the skew presented between IN_Dn+ and IN_Dn- paired input pins.
- [5] This lane-to-lane skew budget is in addition to skew between differential input pairs.
- [6] Jitter budget for differential signals as they pass through the level shifter.

11.3 HPD_SINK input, HPD_SOURCE output

Table 12. HPD characteristics

| Symbol | Parameter | Conditions | Min | Typ | Max | Unit |
|----------|---------------------------|---|---------|-----|----------|------------|
| V_{IH} | HIGH-level input voltage | HPD_SINK | [1] 2.0 | 5.0 | 5.3 | V |
| V_{IL} | LOW-level input voltage | HPD_SINK | 0 | - | 0.8 | V |
| I_{LI} | input leakage current | HPD_SINK | - | - | 15 | μ A |
| V_{OH} | HIGH-level output voltage | HPD_SOURCE | 2.5 | - | V_{DD} | V |
| V_{OL} | LOW-level output voltage | HPD_SOURCE | 0 | - | 0.2 | V |
| t_{PD} | propagation delay | from HPD_SINK to HPD_SOURCE; 50 % to 50 % | [2] - | - | 200 | ns |
| t_t | transition time | HPD_SOURCE rise/fall; 10 % to 90 % | [3] 1 | - | 20 | ns |
| R_{pd} | pull-down resistance | HPD_SINK input pull-down resistor | [4] 100 | 200 | 300 | k Ω |

- [1] Low-speed input changes state on cable plug/unplug.
- [2] Time from HPD_SINK changing state to HPD_SOURCE changing state. Includes HPD_SOURCE rise/fall time.
- [3] Time required to transition from V_{OH} to V_{OL} or from V_{OL} to V_{OH} .
- [4] Guarantees HPD_SINK is LOW when no display is plugged in.

11.4 OE_N, DDC_EN and DDET inputs

Table 13. OE_N, DDC_EN and DDET input characteristics

| Symbol | Parameter | Conditions | Min | Typ | Max | Unit |
|----------|--------------------------|------------|-------|-----|-----|---------|
| V_{IH} | HIGH-level input voltage | | 2.0 | - | | V |
| V_{IL} | LOW-level input voltage | | | - | 0.8 | V |
| I_{LI} | input leakage current | OE_N pin | [1] - | - | 10 | μ A |

[1] Measured with input at V_{IH} maximum and V_{IL} minimum.

11.5 DDC characteristics

Table 14. DDC characteristics

| Symbol | Parameter | Conditions | Min | Typ | Max | Unit |
|---|--|---|--------------|------|---------------|---------|
| Input and output SCL_SOURCE and SDA_SOURCE; $V_{CC1} = 3.0$ V to 3.6 V[1] | | | | | | |
| V_{IH} | HIGH-level input voltage | | $0.7V_{CC1}$ | - | 3.6 | V |
| V_{IL} | LOW-level input voltage | | -0.5 | - | $+0.3V_{CC1}$ | V |
| V_{ILc} | contention LOW-level input voltage | | -0.5 | 0.4 | - | V |
| I_{LI} | input leakage current | $V_I = 3.6$ V | - | - | 10 | μ A |
| I_{IL} | LOW-level input current | $V_I = 0.2$ V | - | - | 10 | μ A |
| V_{OL} | LOW-level output voltage | $I_{OL} = 100$ μ A or 6 mA | 0.47 | 0.52 | 0.6 | V |
| $V_{OL} - V_{ILc}$ | difference between LOW-level output and LOW-level input voltage contention | guaranteed by design | - | - | 70 | mV |
| C_{io} | input/output capacitance | $V_I = 3$ V or 0 V; $V_{DD} = 3.3$ V | - | 6 | 7 | pF |
| | | $V_I = 3$ V or 0 V; $V_{DD} = 0$ V | - | 6 | 7 | pF |
| Input and output SDA_SINK and SCL_SINK; $V_{CC2} = 4.5$ V to 5.5 V[2] | | | | | | |
| V_{IH} | HIGH-level input voltage | | $0.7V_{CC2}$ | - | 5.5 | V |
| V_{IL} | LOW-level input voltage | | -0.5 | - | +1.5 | V |
| I_{LI} | input leakage current | $V_I = 5.5$ V | - | - | 10 | μ A |
| I_{IL} | LOW-level input current | $V_I = 0.2$ V | - | - | 10 | μ A |
| V_{OL} | LOW-level output voltage | $I_{OL} = 6$ mA | - | 0.1 | 0.2 | V |
| C_{io} | input/output capacitance | $V_I = 3$ V or 0 V; $V_{DD} = 3.3$ V | - | - | 7 | pF |
| | | $V_I = 3$ V or 0 V; $V_{DD} = 0$ V | - | 6 | 7 | pF |
| $I_{trt(pu)}$ | transient boosted pull-up current | $V_{CC2} = 4.5$ V; slew rate = 1.25 V/ μ s | - | 6 | - | mA |

[1] V_{CC1} is the pull-up voltage for DDC source.

[2] V_{CC2} is the pull-up voltage for DDC sink.

11.6 5 V DC regulator characteristics

Table 15. 5 V DC regulator characteristics

| Symbol | Parameter | Conditions | Min | Typ | Max | Unit |
|----------------------|------------------------------------|------------------------------|-------|-----|-----|---------|
| V_{DD} | supply voltage | | 3.0 | 3.3 | 3.6 | V |
| V_O | output voltage | 5 V regulator output | 4.7 | 5 | 5.3 | V |
| I_{load} | load current | 5 V regulator output | - | - | 75 | mA |
| $I_{O(sc)}$ | short-circuit output current | | 100 | 150 | 200 | mA |
| I_{bckdrv} | backdrive current | 5 V regulator output | - | - | 10 | μ A |
| $V_{O(ripple)(p-p)}$ | peak-to-peak ripple output voltage | $C_{O(reg)} = 1 \mu\text{F}$ | [1] - | 250 | 400 | mV |
| η | efficiency | $I_{load} > 10 \text{ mA}$ | 70 | 75 | 80 | % |

[1] Recommend low ESR ceramic output capacitor of 2 μF to reduce the output ripple.

12. Package outline

HVQFN48: plastic thermal enhanced very thin quad flat package; no leads; 48 terminals; body 7 x 7 x 0.85 mm

SOT619-1

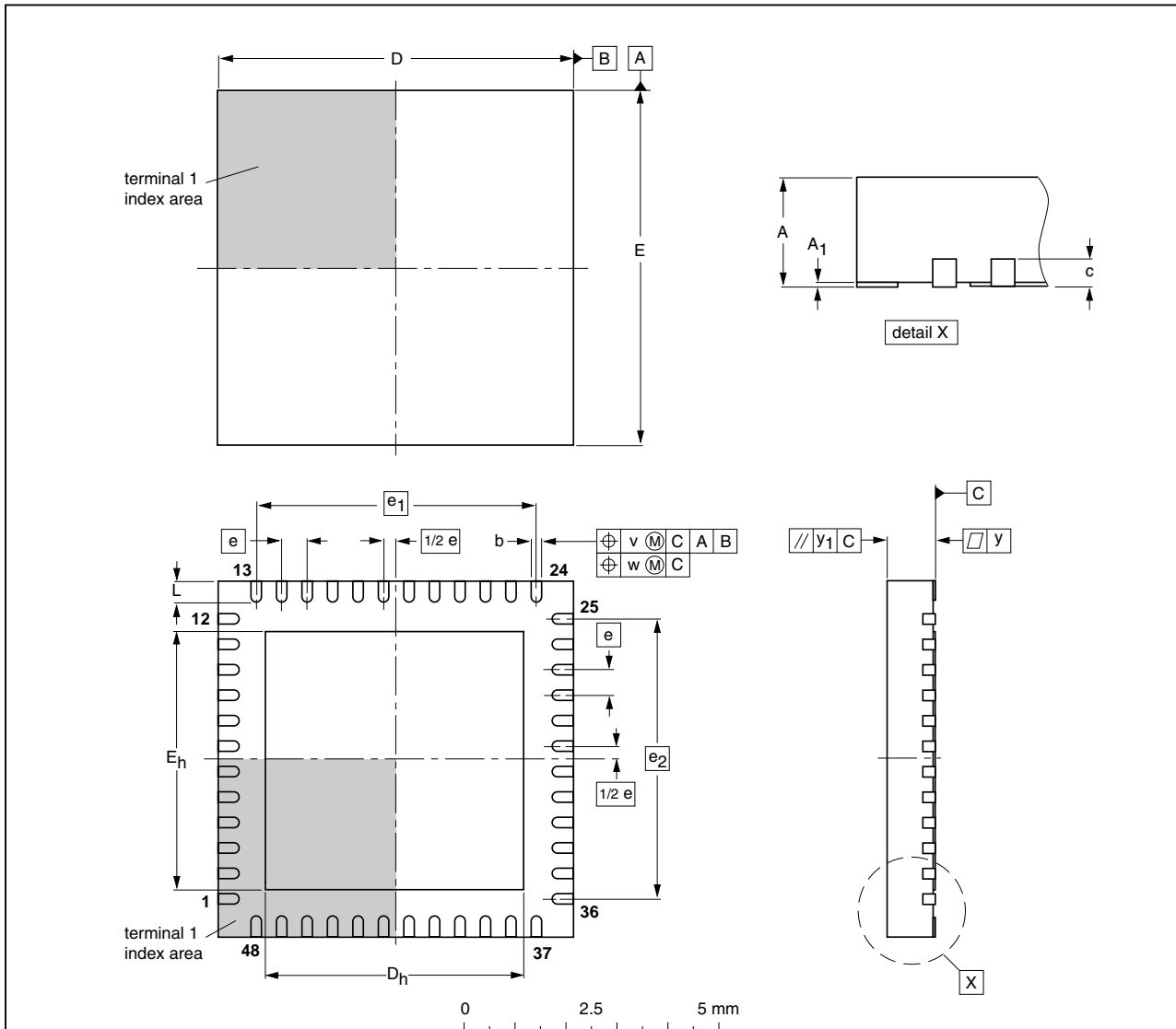

DIMENSIONS (mm are the original dimensions)

| UNIT | A ⁽¹⁾ max. | A ₁ | b | c | D ⁽¹⁾ | D _h | E ⁽¹⁾ | E _h | e | e ₁ | e ₂ | L | v | w | y | y ₁ |
|------|-----------------------|----------------|--------------|-----|------------------|----------------|------------------|----------------|-----|----------------|----------------|------------|-----|------|------|----------------|
| mm | 1 | 0.05 0.00 | 0.30 0.18 | 0.2 | 7.1 6.9 | 5.25 4.95 | 7.1 6.9 | 5.25 4.95 | 0.5 | 5.5 | 5.5 | 0.5 0.3 | 0.1 | 0.05 | 0.05 | 0.1 |

Note

1. Plastic or metal protrusions of 0.075 mm maximum per side are not included.

| OUTLINE VERSION | REFERENCES | | | | EUROPEAN PROJECTION | ISSUE DATE |
|-----------------|------------|--------|-------|--|---------------------|----------------------|
| | IEC | JEDEC | JEITA | | | |
| SOT619-1 | --- | MO-220 | --- | | | 01-08-08 02-10-18 |

Fig 9. Package outline SOT619-1 (HVQFN48)

13. Soldering of SMD packages

This text provides a very brief insight into a complex technology. A more in-depth account of soldering ICs can be found in Application Note *AN10365 "Surface mount reflow soldering description"*.

13.1 Introduction to soldering

Soldering is one of the most common methods through which packages are attached to Printed Circuit Boards (PCBs), to form electrical circuits. The soldered joint provides both the mechanical and the electrical connection. There is no single soldering method that is ideal for all IC packages. Wave soldering is often preferred when through-hole and Surface Mount Devices (SMDs) are mixed on one printed wiring board; however, it is not suitable for fine pitch SMDs. Reflow soldering is ideal for the small pitches and high densities that come with increased miniaturization.

13.2 Wave and reflow soldering

Wave soldering is a joining technology in which the joints are made by solder coming from a standing wave of liquid solder. The wave soldering process is suitable for the following:

- Through-hole components
- Leaded or leadless SMDs, which are glued to the surface of the printed circuit board

Not all SMDs can be wave soldered. Packages with solder balls, and some leadless packages which have solder lands underneath the body, cannot be wave soldered. Also, leaded SMDs with leads having a pitch smaller than ~0.6 mm cannot be wave soldered, due to an increased probability of bridging.

The reflow soldering process involves applying solder paste to a board, followed by component placement and exposure to a temperature profile. Leaded packages, packages with solder balls, and leadless packages are all reflow solderable.

Key characteristics in both wave and reflow soldering are:

- Board specifications, including the board finish, solder masks and vias
- Package footprints, including solder thieves and orientation
- The moisture sensitivity level of the packages
- Package placement
- Inspection and repair
- Lead-free soldering versus SnPb soldering

13.3 Wave soldering

Key characteristics in wave soldering are:

- Process issues, such as application of adhesive and flux, clinching of leads, board transport, the solder wave parameters, and the time during which components are exposed to the wave
- Solder bath specifications, including temperature and impurities

13.4 Reflow soldering

Key characteristics in reflow soldering are:

- Lead-free versus SnPb soldering; note that a lead-free reflow process usually leads to higher minimum peak temperatures (see [Figure 10](#)) than a SnPb process, thus reducing the process window
- Solder paste printing issues including smearing, release, and adjusting the process window for a mix of large and small components on one board
- Reflow temperature profile; this profile includes preheat, reflow (in which the board is heated to the peak temperature) and cooling down. It is imperative that the peak temperature is high enough for the solder to make reliable solder joints (a solder paste characteristic). In addition, the peak temperature must be low enough that the packages and/or boards are not damaged. The peak temperature of the package depends on package thickness and volume and is classified in accordance with [Table 16](#) and [17](#)

Table 16. SnPb eutectic process (from J-STD-020C)

| Package thickness (mm) | Package reflow temperature (°C) | |
|------------------------|---------------------------------|-------|
| | Volume (mm ³) | |
| | < 350 | ≥ 350 |
| < 2.5 | 235 | 220 |
| ≥ 2.5 | 220 | 220 |

Table 17. Lead-free process (from J-STD-020C)

| Package thickness (mm) | Package reflow temperature (°C) | | |
|------------------------|---------------------------------|-------------|--------|
| | Volume (mm ³) | | |
| | < 350 | 350 to 2000 | > 2000 |
| < 1.6 | 260 | 260 | 260 |
| 1.6 to 2.5 | 260 | 250 | 245 |
| > 2.5 | 250 | 245 | 245 |

Moisture sensitivity precautions, as indicated on the packing, must be respected at all times.

Studies have shown that small packages reach higher temperatures during reflow soldering, see [Figure 10](#).

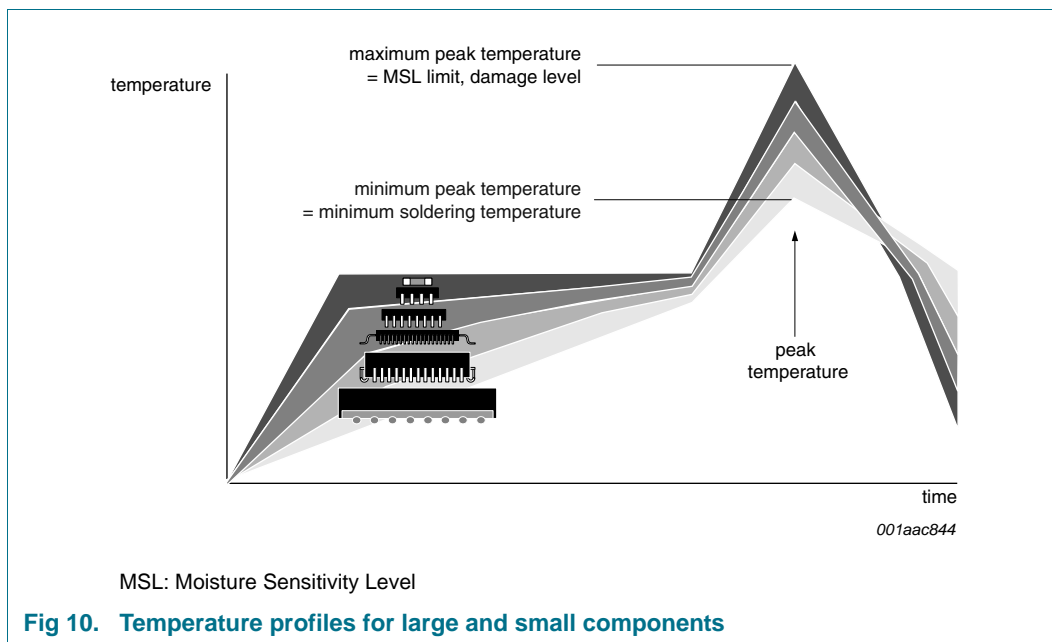

For further information on temperature profiles, refer to Application Note AN10365 “Surface mount reflow soldering description”.

14. Abbreviations

Table 18. Abbreviations

| Acronym | Description |
|----------------------|---|
| CDM | Charged-Device Model |
| CEC | Consumer Electronics Control |
| DDC | Data Display Channel |
| DVI | Digital Visual Interface |
| ESD | ElectroStatic Discharge |
| ESR | Equivalent Series Resistance |
| HBM | Human Body Model |
| HDMI | High-Definition Multimedia Interface |
| HPD | Hot Plug Detect |
| I ² C-bus | Inter-IC bus |
| I/O | Input/Output |
| TMDS | Transition Minimized Differential Signaling |
| VESA | Video Electronic Standards Association |

15. Revision history

Table 19. Revision history

| Document ID | Release date | Data sheet status | Change notice | Supersedes |
|--------------|--------------|--------------------|---------------|--------------|
| PTN3381B v.2 | 20101015 | Product data sheet | - | PTN3381B v.1 |
| PTN3381B v.1 | 20100930 | Product data sheet | - | - |

16. Legal information

16.1 Data sheet status

| Document status ^{[1][2]} | Product status ^[3] | Definition |
|-----------------------------------|-------------------------------|---|
| Objective [short] data sheet | Development | This document contains data from the objective specification for product development. |
| Preliminary [short] data sheet | Qualification | This document contains data from the preliminary specification. |
| Product [short] data sheet | Production | This document contains the product specification. |

[1] Please consult the most recently issued document before initiating or completing a design.

[2] The term 'short data sheet' is explained in section "Definitions".

[3] The product status of device(s) described in this document may have changed since this document was published and may differ in case of multiple devices. The latest product status information is available on the Internet at URL <http://www.nxp.com>.

16.2 Definitions

Draft — The document is a draft version only. The content is still under internal review and subject to formal approval, which may result in modifications or additions. NXP Semiconductors does not give any representations or warranties as to the accuracy or completeness of information included herein and shall have no liability for the consequences of use of such information.

Short data sheet — A short data sheet is an extract from a full data sheet with the same product type number(s) and title. A short data sheet is intended for quick reference only and should not be relied upon to contain detailed and full information. For detailed and full information see the relevant full data sheet, which is available on request via the local NXP Semiconductors sales office. In case of any inconsistency or conflict with the short data sheet, the full data sheet shall prevail.

Product specification — The information and data provided in a Product data sheet shall define the specification of the product as agreed between NXP Semiconductors and its customer, unless NXP Semiconductors and customer have explicitly agreed otherwise in writing. In no event however, shall an agreement be valid in which the NXP Semiconductors product is deemed to offer functions and qualities beyond those described in the Product data sheet.

16.3 Disclaimers

Limited warranty and liability — Information in this document is believed to be accurate and reliable. However, NXP Semiconductors does not give any representations or warranties, expressed or implied, as to the accuracy or completeness of such information and shall have no liability for the consequences of use of such information.

In no event shall NXP Semiconductors be liable for any indirect, incidental, punitive, special or consequential damages (including - without limitation - lost profits, lost savings, business interruption, costs related to the removal or replacement of any products or rework charges) whether or not such damages are based on tort (including negligence), warranty, breach of contract or any other legal theory.

Notwithstanding any damages that customer might incur for any reason whatsoever, NXP Semiconductors' aggregate and cumulative liability towards customer for the products described herein shall be limited in accordance with the *Terms and conditions of commercial sale* of NXP Semiconductors.

Right to make changes — NXP Semiconductors reserves the right to make changes to information published in this document, including without limitation specifications and product descriptions, at any time and without notice. This document supersedes and replaces all information supplied prior to the publication hereof.

Suitability for use — NXP Semiconductors products are not designed, authorized or warranted to be suitable for use in life support, life-critical or safety-critical systems or equipment, nor in applications where failure or

malfunction of an NXP Semiconductors product can reasonably be expected to result in personal injury, death or severe property or environmental damage. NXP Semiconductors accepts no liability for inclusion and/or use of NXP Semiconductors products in such equipment or applications and therefore such inclusion and/or use is at the customer's own risk.

Applications — Applications that are described herein for any of these products are for illustrative purposes only. NXP Semiconductors makes no representation or warranty that such applications will be suitable for the specified use without further testing or modification.

Customers are responsible for the design and operation of their applications and products using NXP Semiconductors products, and NXP Semiconductors accepts no liability for any assistance with applications or customer product design. It is customer's sole responsibility to determine whether the NXP Semiconductors product is suitable and fit for the customer's applications and products planned, as well as for the planned application and use of customer's third party customer(s). Customers should provide appropriate design and operating safeguards to minimize the risks associated with their applications and products.

NXP Semiconductors does not accept any liability related to any default, damage, costs or problem which is based on any weakness or default in the customer's applications or products, or the application or use by customer's third party customer(s). Customer is responsible for doing all necessary testing for the customer's applications and products using NXP Semiconductors products in order to avoid a default of the applications and the products or of the application or use by customer's third party customer(s). NXP does not accept any liability in this respect.

Limiting values — Stress above one or more limiting values (as defined in the Absolute Maximum Ratings System of IEC 60134) will cause permanent damage to the device. Limiting values are stress ratings only and (proper) operation of the device at these or any other conditions above those given in the Recommended operating conditions section (if present) or the Characteristics sections of this document is not warranted. Constant or repeated exposure to limiting values will permanently and irreversibly affect the quality and reliability of the device.

Terms and conditions of commercial sale — NXP Semiconductors products are sold subject to the general terms and conditions of commercial sale, as published at <http://www.nxp.com/profile/terms>, unless otherwise agreed in a valid written individual agreement. In case an individual agreement is concluded only the terms and conditions of the respective agreement shall apply. NXP Semiconductors hereby expressly objects to applying the customer's general terms and conditions with regard to the purchase of NXP Semiconductors products by customer.

No offer to sell or license — Nothing in this document may be interpreted or construed as an offer to sell products that is open for acceptance or the grant, conveyance or implication of any license under any copyrights, patents or other industrial or intellectual property rights.

Export control — This document as well as the item(s) described herein may be subject to export control regulations. Export might require a prior authorization from national authorities.

Non-automotive qualified products — Unless this data sheet expressly states that this specific NXP Semiconductors product is automotive qualified, the product is not suitable for automotive use. It is neither qualified nor tested in accordance with automotive testing or application requirements. NXP Semiconductors accepts no liability for inclusion and/or use of non-automotive qualified products in automotive equipment or applications.

In the event that customer uses the product for design-in and use in automotive applications to automotive specifications and standards, customer (a) shall use the product without NXP Semiconductors' warranty of the product for such automotive applications, use and specifications, and (b) whenever customer uses the product for automotive applications beyond NXP Semiconductors' specifications such use shall be solely at customer's own risk, and (c) customer fully indemnifies NXP Semiconductors for any liability, damages or failed product claims resulting from customer design and use of the product for automotive applications beyond NXP Semiconductors' standard warranty and NXP Semiconductors' product specifications.

17. Contact information

For more information, please visit: <http://www.nxp.com>

For sales office addresses, please send an email to: salesaddresses@nxp.com

16.4 Licenses

Purchase of NXP ICs with HDMI technology

Use of an NXP IC with HDMI technology in equipment that complies with the HDMI standard requires a license from HDMI Licensing LLC, 1060 E. Arques Avenue Suite 100, Sunnyvale CA 94085, USA, e-mail: admin@hdmi.org.

16.5 Trademarks

Notice: All referenced brands, product names, service names and trademarks are the property of their respective owners.

18. Contents

| | | | | | |
|-----------|--|-----------|-----------|--|-----------|
| 1 | General description | 1 | 12 | Package outline | 23 |
| 2 | Features and benefits | 3 | 13 | Soldering of SMD packages | 24 |
| 2.1 | High-speed TMDS level shifting | 3 | 13.1 | Introduction to soldering | 24 |
| 2.2 | DDC level shifting | 3 | 13.2 | Wave and reflow soldering | 24 |
| 2.3 | HDMI dongle detect support | 3 | 13.3 | Wave soldering | 24 |
| 2.4 | HPD level shifting | 3 | 13.4 | Reflow soldering | 25 |
| 2.5 | 5 V DC voltage regulator | 3 | 14 | Abbreviations | 26 |
| 2.6 | General | 4 | 15 | Revision history | 27 |
| 3 | Applications | 4 | 16 | Legal information | 28 |
| 4 | Ordering information | 4 | 16.1 | Data sheet status | 28 |
| 5 | Functional diagram | 5 | 16.2 | Definitions | 28 |
| 6 | Pinning information | 6 | 16.3 | Disclaimers | 28 |
| 6.1 | Pinning | 6 | 16.4 | Licenses | 29 |
| 6.2 | Pin description | 6 | 16.5 | Trademarks | 29 |
| 7 | Functional description | 9 | 17 | Contact information | 29 |
| 7.1 | Enable and disable features | 10 | 18 | Contents | 30 |
| 7.1.1 | Hot plug detect | 10 | | | |
| 7.1.2 | Output Enable function (OE_N) | 10 | | | |
| 7.1.3 | DDC channel enable function (DDC_EN) | 10 | | | |
| 7.1.4 | Enable/disable truth table | 11 | | | |
| 7.2 | Analog current reference | 12 | | | |
| 7.3 | Programmable pre-emphasis | 12 | | | |
| 7.4 | Backdrive current protection | 12 | | | |
| 7.5 | Active DDC buffer with rise time accelerator | 13 | | | |
| 7.6 | I ² C-bus based HDMI dongle detection | 13 | | | |
| 7.6.1 | Slave address | 13 | | | |
| 7.6.2 | Read operation | 14 | | | |
| 7.7 | Characteristics of the I ² C-bus | 15 | | | |
| 7.7.1 | Bit transfer | 15 | | | |
| 7.7.2 | START and STOP conditions | 15 | | | |
| 7.7.3 | System configuration | 15 | | | |
| 7.7.4 | Acknowledge | 16 | | | |
| 8 | Application design-in information | 17 | | | |
| 8.1 | Dongle or cable adaptor detect discovery mechanism | 17 | | | |
| 9 | Limiting values | 18 | | | |
| 10 | Recommended operating conditions | 18 | | | |
| 10.1 | Current consumption | 19 | | | |
| 11 | Characteristics | 19 | | | |
| 11.1 | Differential inputs | 19 | | | |
| 11.2 | Differential outputs | 20 | | | |
| 11.3 | HPD_SINK input, HPD_SOURCE output | 20 | | | |
| 11.4 | OE_N, DDC_EN and DDET inputs | 21 | | | |
| 11.5 | DDC characteristics | 21 | | | |
| 11.6 | 5 V DC regulator characteristics | 22 | | | |

Please be aware that important notices concerning this document and the product(s) described herein, have been included in section 'Legal information'.

© NXP B.V. 2010.

All rights reserved.

For more information, please visit: <http://www.nxp.com>

For sales office addresses, please send an email to: salesaddresses@nxp.com

Date of release: 15 October 2010

Document identifier: PTN3381B