

## Dual, High-PSRR, Low-Noise, Low-Dropout, 300mA CMOS Linear Regulator

### General Description

The EMP2033 series is a family of dual-channel CMOS linear regulators featuring ultra-high power supply rejection ratio (PSRR), low output voltage noise, low dropout voltage, low quiescent current and fast transient response. It guarantees delivery of 300mA output current per regulator, and supports preset output voltages ranging from 1.2V to 3.3V with 0.1V increment (except for 1.85V and 2.85V).

The EMP2033 is well suited for portable battery-powered application which requires high efficiency, low noise and small board space. With 150mV low dropout voltage at 300mA output current, EMP2033 sustains high PSRR at very low input voltage which is common in battery-powered application. The EMP2033 also features 120µV<sub>RMS</sub> low output voltage noise without the presence of a noise bypass capacitor, which fits the application where noise and board space are both concerned.

Each regulator in the EMP2033 can be turned off independently, further prolonging the battery life. Internally built-in thermal protection and over-current protection provide additional safety for the end use. The EMP2033 is available in miniature 6-pin SOT-23-6, 6-pin FBP and TDFN (2x2) packages.

#### ■ Typical Application Diagram

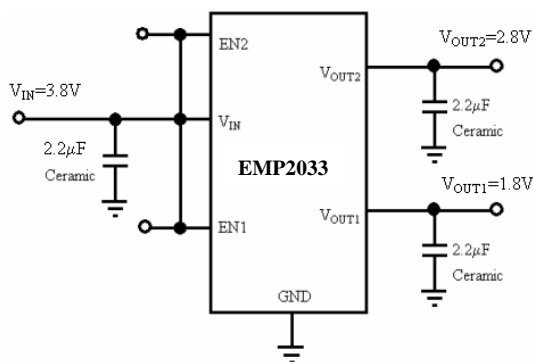

### Features

- Miniature SOT-23-6 and TDFN-2x2-6 packages
- 300mA guaranteed output current
- 72dB typical PSRR at 1kHz (60dB typical at 10kHz)
- 120µV<sub>RMS</sub> output voltage noise (10Hz to 100kHz)
- 150mV typical dropout at 300mA
- 150µA typical quiescent current
- Less than 1µA typical shutdown mode
- Auto-discharge during chip disable
- Fast line and load transient response
- 30µs typical turn-on time
- 2.5V to 5.5V input range
- Stable with small ceramic output capacitors
- Over temperature and over current protection
- ±2% output voltage tolerance

### Applications

- Wireless handsets
- PCMCIA cards
- DSP core power
- Hand-held instruments
- Battery-powered systems
- Portable information appliances

#### ■ Typical Performance Characteristics

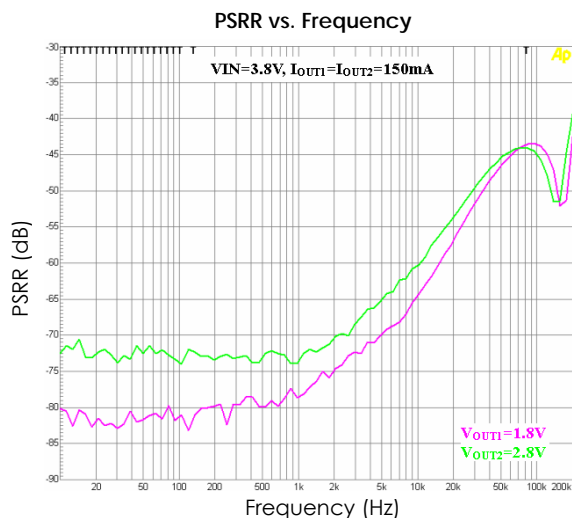

## Connection Diagrams

### SOT-23-6

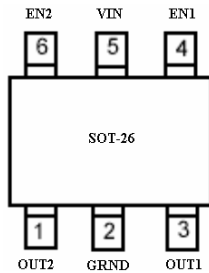

## Order information

EMP2033-XXVC06GRR/NRR

|      |                                  |
|------|----------------------------------|
| XX   | Output Operation                 |
| VC06 | SOT-23-6 Package                 |
| GRR  | RoHS (Pb Free)                   |
|      | Rating: -40 to 85°C              |
|      | Package in Tape & Reel           |
| NRR  | RoHS & Halogen free (By Request) |
|      | Rating: -40 to 85°C              |
|      | Package in Tape & Reel           |

### TDFN-6

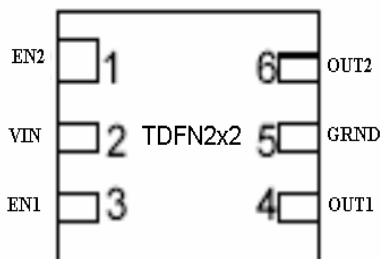

EMP2033-XXFE06NRR

|      |                        |
|------|------------------------|
| XX   | Output Operation       |
| FE06 | TDFN-6 Package         |
| NRR  | RoHS & Halogen free    |
|      | Rating: -40 to 85°C    |
|      | Package in Tape & Reel |

| Name | SOT-23-6 | TDFN2x2 | Function  |
|------|----------|---------|---|
| OUT2 | 1        | 6       | Output Voltage Feedback of Regulator 2  |
| GRND | 2        | 5       | Ground Pin.   |
| OUT1 | 3        | 4       | Output Voltage Feedback of Regulator 1  |
| EN1  | 4        | 3       | <b>Enable Input of Regulator 1.</b> Set regulator 1 into the disable mode by pulling the EN1 pin low. To keep regulator 1 on during normal operation, connect the EN1 pin to VIN. The EN1 pin must not exceed VIN under all operating conditions. |
| VIN  | 5        | 2       | <b>Supply Voltage Input.</b> Require a minimum input capacitor of close to 1μF to ensure stability and sufficient decoupling from the ground pin.   |
| EN2  | 6        | 1       | <b>Enable Input of Regulator 2.</b> Set regulator 2 into the disable mode by pulling the EN2 pin low. To keep regulator 2 on during normal operation, connect the EN2 pin to VIN. The EN2 pin must not exceed VIN under all operating conditions. |

Note: EN1 and EN2-pin can't be floating

## Order, Mark & Packing Information

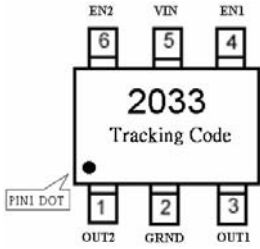
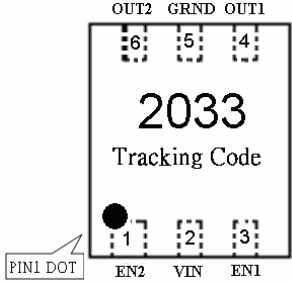
| No. of PIN | EN1  | EN2               | Package  | Marking   | Vout1 | Vout2 | Product ID        |        |  |     |     |            |
|------------|------|-------------------|----------|---|-------|-------|-------------------|--------|--|-----|-----|------------|
| 6          | Y    | Y                 | SOT-23-6 |  | 3.0   | 3.0   | EMP2033-00VC06GRR |        |  |     |     |            |
|            |      |                   |          |   | 1.8   | 3.0   | EMP2033-01VC06GRR |        |  |     |     |            |
|            |      |                   |          |   | 1.8   | 2.8   | EMP2033-02VC06GRR |        |  |     |     |            |
|            |      |                   |          |   | 2.5   | 3.3   | EMP2033-03VC06GRR |        |  |     |     |            |
|            |      |                   |          |   | 2.8   | 3.3   | EMP2033-04VC06GRR |        |  |     |     |            |
|            |      |                   |          |   | 1.8   | 3.3   | EMP2033-05VC06GRR |        |  |     |     |            |
|            |      |                   |          |   | 2.85  | 2.85  | EMP2033-06VC06GRR |        |  |     |     |            |
|            |      |                   |          |   | 1.5   | 2.8   | EMP2033-07VC06GRR |        |  |     |     |            |
|            |      |                   |          |   | 1.2   | 2.8   | EMP2033-11VC06GRR |        |  |     |     |            |
|            |      |                   |          |   | 1.5   | 2.5   | EMP2033-12VC06GRR |        |  |     |     |            |
|            |      |                   |          |   | 6     | Y     | Y                 | TDFN-6 |  | 3.0 | 3.0 | By Request |
|            |      |                   |          |   |       |       |                   |        |  | 1.8 | 3.0 | By Request |
| 1.8        | 2.8  | By Request        |          |   |       |       |                   |        |  |     |     |            |
| 2.5        | 3.3  | By Request        |          |   |       |       |                   |        |  |     |     |            |
| 2.8        | 3.3  | By Request        |          |   |       |       |                   |        |  |     |     |            |
| 1.8        | 3.3  | By Request        |          |   |       |       |                   |        |  |     |     |            |
| 2.85       | 2.85 | By Request        |          |   |       |       |                   |        |  |     |     |            |
| 1.5        | 2.8  | By Request        |          |   |       |       |                   |        |  |     |     |            |
| 1.2        | 2.8  | EMP2033-11FE06NRR |          |   |       |       |                   |        |  |     |     |            |
| 1.5        | 2.5  | By Request        |          |   |       |       |                   |        |  |     |     |            |

Packing : SOT-23-6 Tape & Reel 3Kpcs

TDFN-6 Tape & Reel 3Kpcs

## Absolute Maximum Ratings (Notes 1, 2)

|  |                |                                      |               |
|--|----------------|--------------------------------------|---------------|
| $V_{IN}, V_{OUT1}, V_{OUT2}, V_{EN1}, V_{EN2}$ | -0.3V to 6.5V  | Thermal Resistance ( $\theta_{JA}$ ) |               |
| Power Dissipation                              | (Note 3)       | TDFN-2X2-6                           | (Note 3)      |
| Storage Temperature Range                      | -65°C to 160°C | SOT-23-6                             | 250°C/W       |
| Junction Temperature ( $T_J$ )                 | 150°C          |                                      |               |
| Lead Temperature (10 sec.)                     | 260°C          | <b>Operating Ratings</b> (Note 1, 2) |               |
| ESD Rating                                     |                | Temperature Range                    | -40°C to 85°C |
| HBM (Note 5)                                   | 2KV            | Supply Voltage                       | 2.5V to 5.5V  |
| MM   | 200V           |                                      |               |

## Electrical Characteristics

Unless otherwise specified, all limits guaranteed for  $V_{IN} = V_{OUT} + 1V$  (Note 6),  $V_{EN1} = V_{EN2} = V_{IN}$ ,  $C_{IN} = C_{OUT} = 2.2\mu F$ ,  $T_J = 25^\circ C$ . **Boldface** limits apply for the operating temperature extremes: -40°C and 85°C.

| Symbol                        | Parameter  | Conditions  | Min        | Typ<br>(Note 7) | Max        | Units                  |
|-------------------------------|--|---|------------|-----------------|------------|------------------------|
| $V_{IN}$                      | Input Voltage  |   | <b>2.5</b> |                 | <b>5.5</b> | V                      |
| $\Delta V_{OTL}$              | Output Voltage Tolerance   | $I_{OUT} = 30mA$<br>$V_{IN} = V_{OUT(NOM)} + 1V$ , (Note 6)       | -2         |                 | +2         | % of<br>$V_{OUT(NOM)}$ |
| $I_{OUT}$                     | Maximum Output Current   | Average DC Current Rating   | <b>300</b> |                 |            | mA                     |
| $I_{LIMIT}$                   | Output Current Limit   |   |            | 600             |            | mA                     |
| $I_Q$                         | Supply Current   | $I_{OUT1} = I_{OUT2} = 0mA$                                       |            | 150             | 225        | $\mu A$                |
|                               |  | $I_{OUT1} = I_{OUT2} = 300mA$                                     |            | 250             |            |                        |
|                               | Shutdown Supply Current  | $EN1 = EN2 = GND$   |            | 0.001           | 1          |                        |
| $V_{DO}$                      | Dropout Voltage<br>(Note 4), (Note 6)  | $I_{OUT} = 30mA$  |            | 15              | 31         | mV                     |
|                               |  | $I_{OUT} = 100mA$   |            | 50              |            |                        |
|                               |  | $I_{OUT} = 300mA$   |            | 150             | 316        |                        |
| PSRR                          | Power-supply rejection ratio<br>$V_{IN}=4.0V, V_{OUT}=3.0V$<br>$I_{OUT}=150mA$ | $f = 1kHz$  |            | 72              |            | dB                     |
|                               |  | $f = 10kHz$   |            | 60              |            |                        |
|                               |  | $f = 100kHz$  |            | 43              |            |                        |
|                               | Power-supply rejection ratio<br>$V_{IN}=3.3V, V_{OUT}=3.0V$<br>$I_{OUT}=30mA$  | $f = 1kHz$  |            | 70              |            |                        |
|                               |  | $f = 10kHz$   |            | 57              |            |                        |
|                               |  | $f = 100kHz$  |            | 42              |            |                        |
| $\Delta V_{OUT}$              | Line Regulation  | $I_{OUT} = 30mA, (V_{OUT} + 1V) \leq V_{IN} \leq 5.5V$ , (Note 6) | -0.1       | 0.01            | 0.1        | %/V                    |
|                               | Load Regulation  | $1mA \leq I_{OUT} \leq 100mA$                                     |            | 6               |            | mV                     |
| $1mA \leq I_{OUT} \leq 300mA$ |  |   |            | 20              |            |                        |
| $e_n$                         | Output Voltage Noise   | $V_{OUT}=2.8V, I_{OUT} = 30mA, 10Hz \leq f \leq 100kHz$ (Note 8)  |            | 120             |            | $\mu V_{RMS}$          |
| $V_{EN}$                      | Enable Input Threshold   | $V_{IH}, (V_{OUT} + 0.5V) \leq V_{IN} \leq 5.5V$<br>(Note 6)      | <b>1.2</b> |                 |            | V                      |
|                               |  | $V_{IL}, (V_{OUT} + 0.5V) \leq V_{IN} \leq 5.5V$<br>(Note 6)      |            |                 | <b>0.4</b> |                        |

|                  |                              |  |  |     |  |    |
|------------------|------------------------------|--|--|-----|--|----|
| T <sub>SD</sub>  | Thermal Shutdown Temperature |  |  | 170 |  | °C |
|                  | Thermal Shutdown Hysteresis  |  |  | 30  |  |    |
| T <sub>ON</sub>  | Turn-On Time                 | V <sub>OUT</sub> at 95% of Final Value |  | 30  |  | μs |
| T <sub>OFF</sub> | Turn-Off Time                | I <sub>OUT</sub> =0mA (Note 9)         |  | 2.4 |  | ms |

**Note 1:** Absolute Maximum ratings indicate limits beyond which damage may occur. Electrical specifications are not applicable when the device is operated outside of its rated operating conditions.

**Note 2:** All voltages are defined and measured with respect to the potential at the ground pin.

**Note 3:** Maximum Power dissipation for the device is calculated using the following equations:

$$P_D = \frac{T_{J(MAX)} - T_A}{\theta_{JA}}$$

where T<sub>J(MAX)</sub> is the maximum junction temperature, T<sub>A</sub> is the ambient temperature, and θ<sub>JA</sub> is the junction-to-ambient thermal resistance. E.g. for the SOT-23-6 package θ<sub>JA</sub> = 250°C/W, T<sub>J(MAX)</sub> = 150°C and using T<sub>A</sub> = 25°C, the maximum power dissipation is found to be 500mW. The derating factor (-1/θ<sub>JA</sub>) = -4mW/°C, thus below 25°C the power dissipation figure can be increased by 4mW per degree, and similarly decreased by this factor for temperatures above 25°C. The value of the θ<sub>JA</sub> for the DFN package is specifically dependent on the PCB trace area, trace material, and the number of layers and thermal vias.

**Note 4:** Dropout voltage is measured by reducing V<sub>IN</sub> until V<sub>OUT</sub> drops 100mV from its nominal value at V<sub>IN</sub> - V<sub>OUT</sub> = 1V. Dropout voltage does not apply to the regulator versions with V<sub>OUT</sub> less than 2.5V.

**Note 5:** Human body model: 1.5kΩ in series with 100pF.

**Note 6:** Condition does not apply to input voltages below 2.5V since this is the minimum input operating voltage.

**Note 7:** Typical Values represent the most likely parametric norm.

**Note 8:** For different output voltage, the noise can be approximately calculated using the following formula:

$$Noise = V_{OUT} \times 42 (\mu V_{RMS})$$

**Note 9:** Turn-off time is time measured between the enable input just decreasing below V<sub>IL</sub> and the output voltage just decreasing to 10% of its nominal value.

## Functional Block Diagram

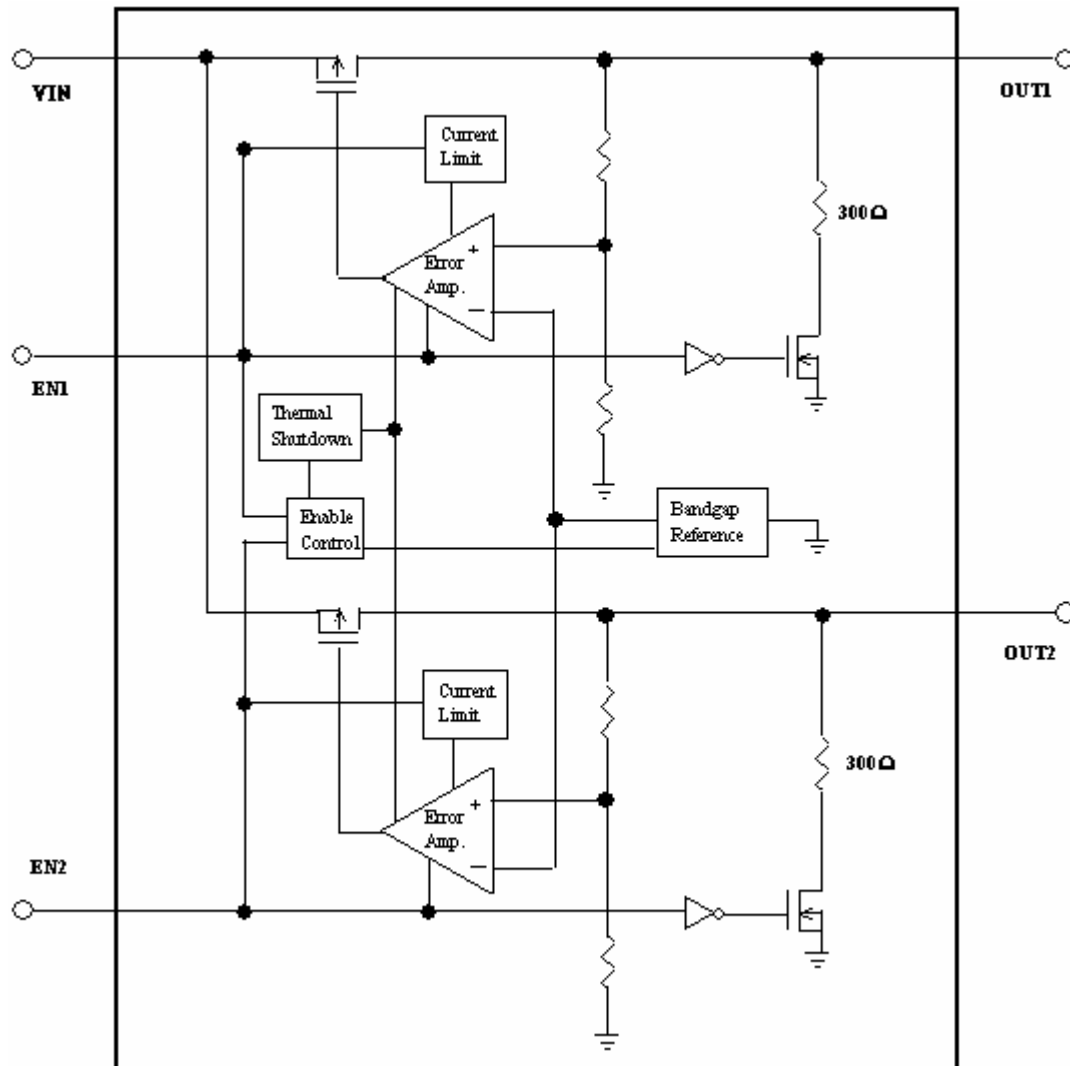

## Typical Performance Characteristics

Unless otherwise specified,  $V_{IN} = V_{OUT(NOM)} + 1V$ ,  $C_{IN} = C_{OUT} = 2.2\mu F$ ,  $T_A = 25^\circ C$ ,  $V_{EN1} = V_{EN2} = V_{IN}$ .

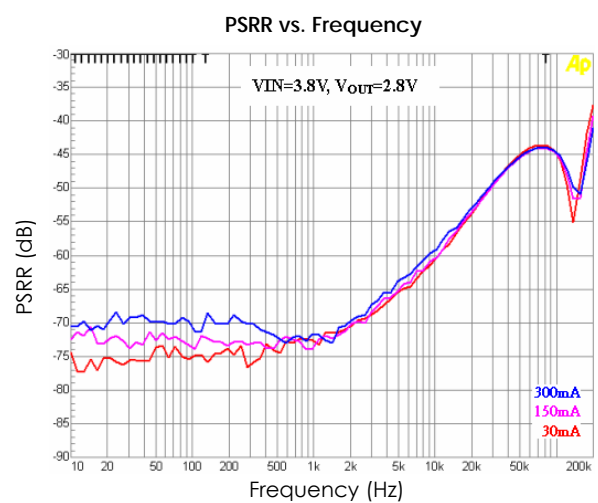
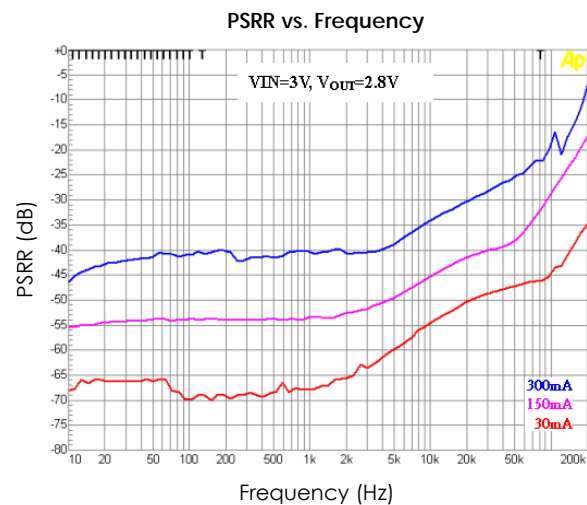
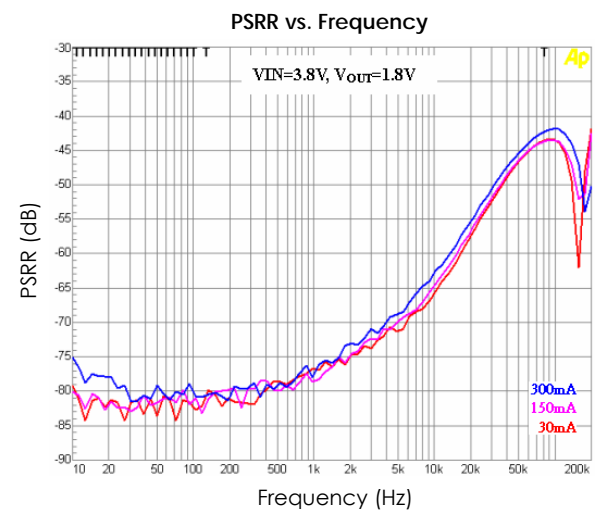
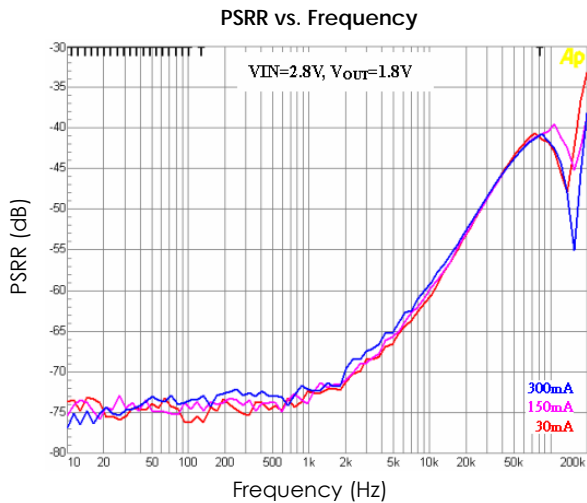
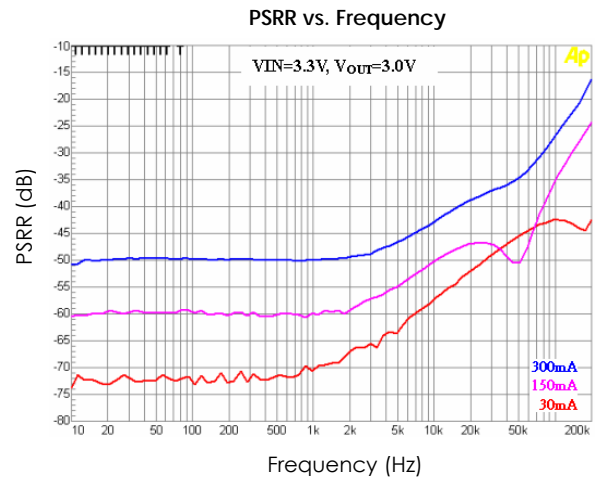
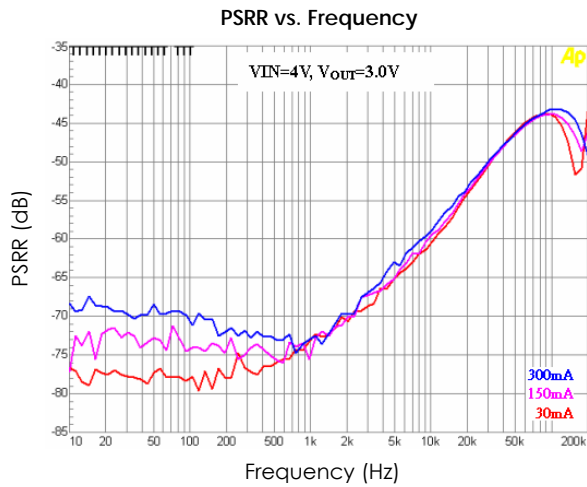

## Typical Performance Characteristics

Unless otherwise specified,  $V_{IN} = V_{OUT(NOM)} + 1V$ ,  $C_{IN} = C_{OUT} = 2.2\mu F$ ,  $T_A = 25^\circ C$ ,  $V_{EN1} = V_{EN2} = V_{IN}$ . (Continued)

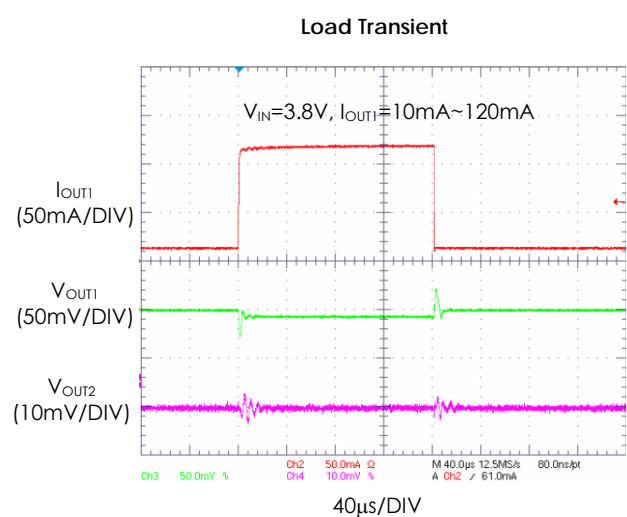
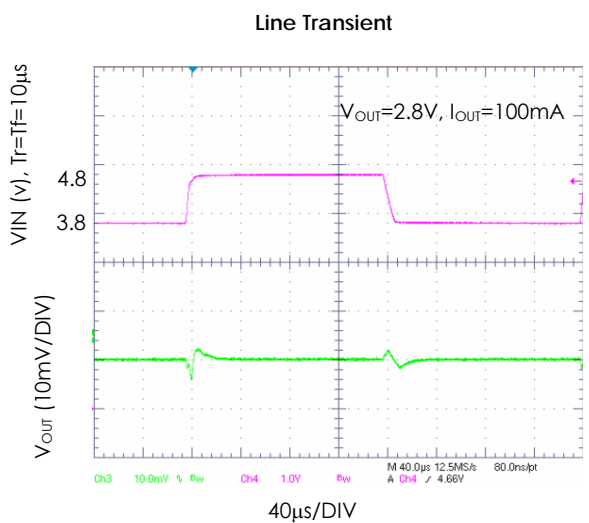
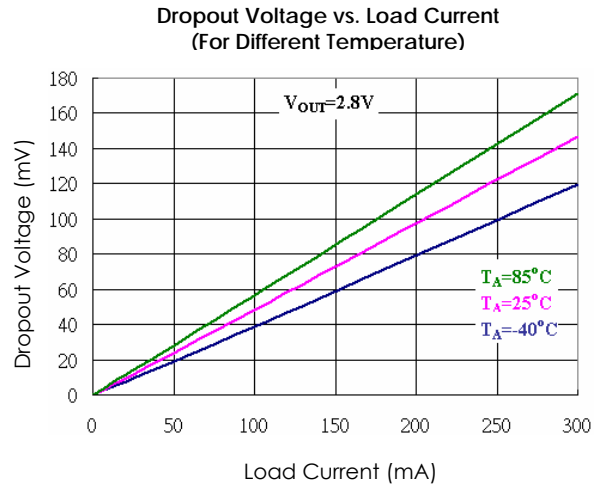
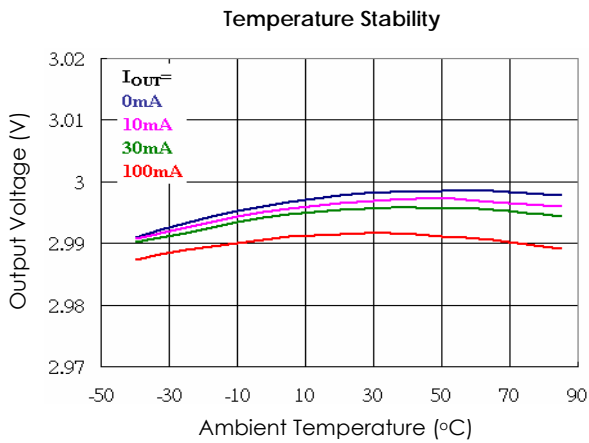
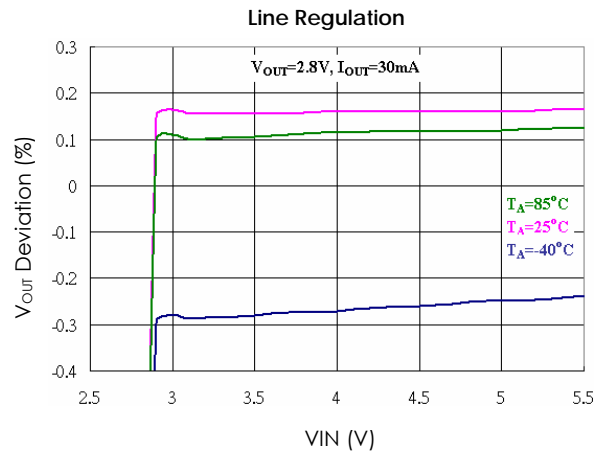
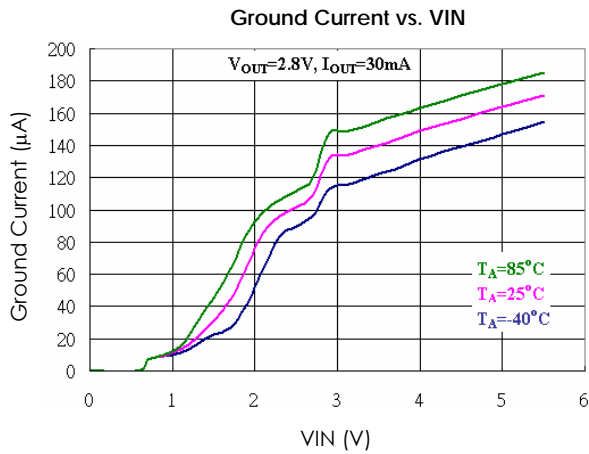



## Typical Performance Characteristics

Unless otherwise specified,  $V_{IN} = V_{OUT(NOM)} + 1V$ ,  $C_{IN} = C_{OUT} = 2.2\mu F$ ,  $T_A = 25^\circ C$ ,  $V_{EN1} = V_{EN2} = V_{IN}$ . (Continued)

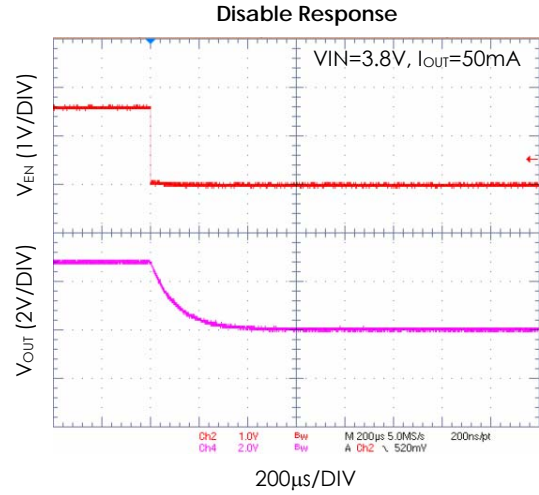
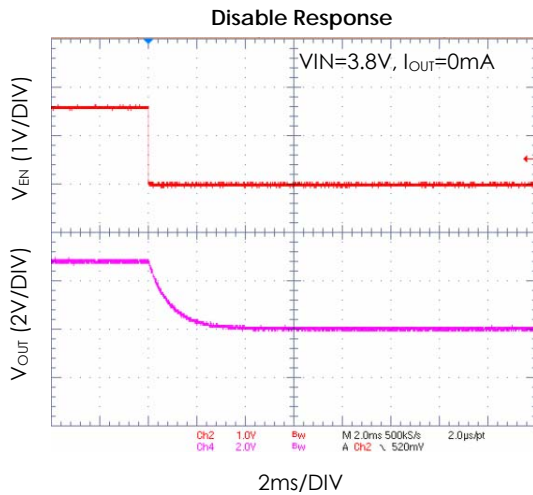
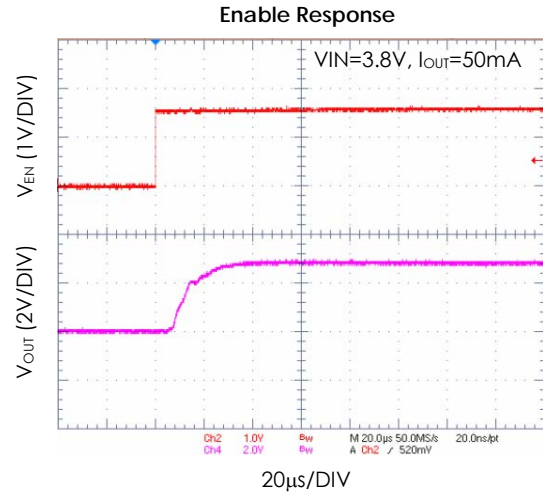
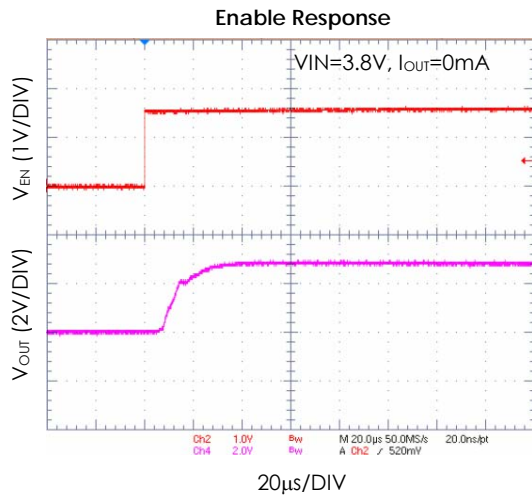

## Physical Dimensions SOT-23-6

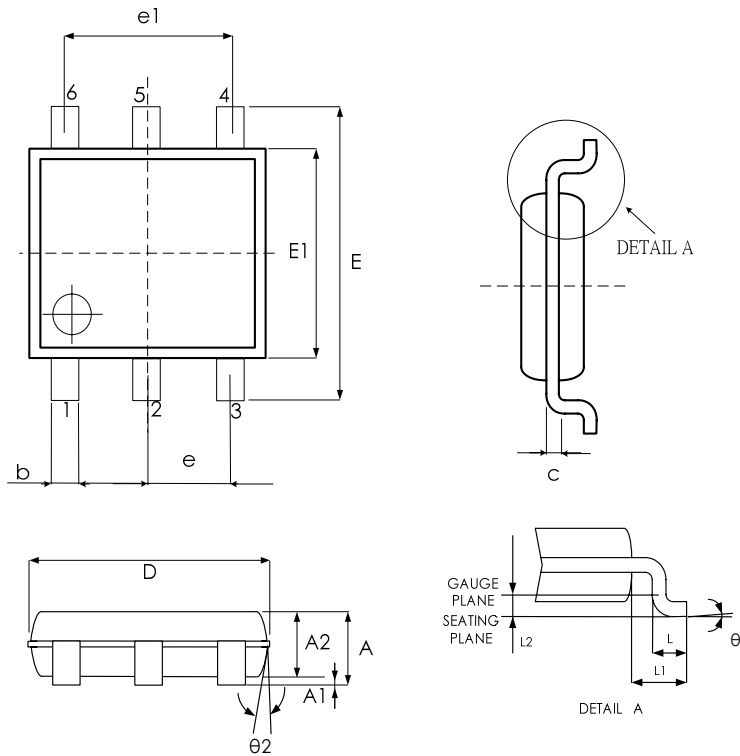

| SYMBPLS         | MIN.      | NOM. | MAX. |
|-----------------|-----------|------|------|
| A               | —         | —    | 1.45 |
| A1              | —         | —    | 0.15 |
| A2              | 0.9       | 1.15 | 1.3  |
| b               | 0.3       | —    | 0.5  |
| c               | 0.08      | —    | 0.22 |
| D               | 2.90 BSC. |      |      |
| E               | 2.80 BSC. |      |      |
| E1              | 1.60 BSC. |      |      |
| e               | 0.95 BSC  |      |      |
| e1              | 1.90 BSC  |      |      |
| L               | 0.3       | 0.45 | 0.6  |
| L1              | 0.60 REF  |      |      |
| L2              | 0.25 REF  |      |      |
| $\theta^\circ$  | 0         | 4    | 8    |
| $\theta2^\circ$ | 5         | 10   | 15   |

UNIT: MM

## TDFN-6

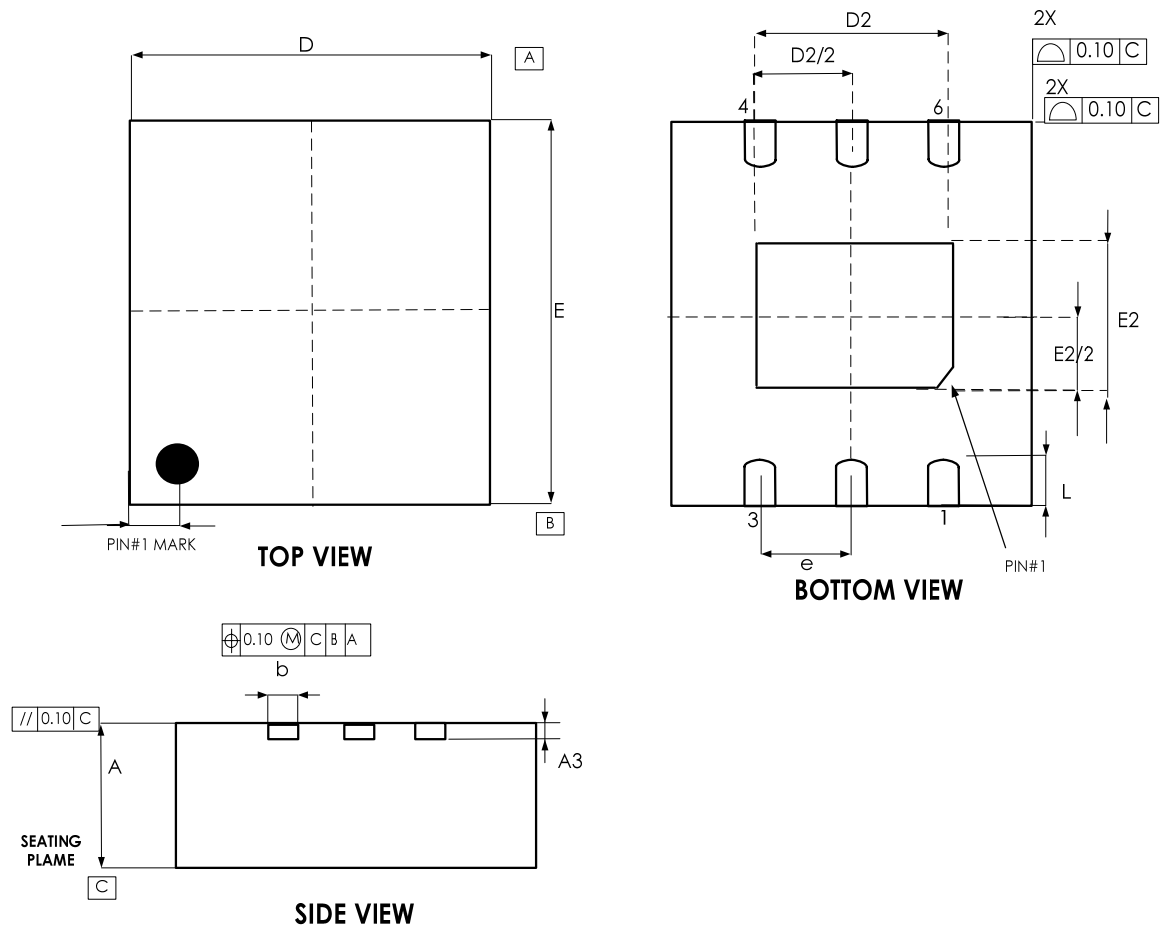

| SYMBOL | COMMON                |      |      |                 |       |       |
|--------|-----------------------|------|------|-----------------|-------|-------|
|        | DIMENSIONS MILLIMETER |      |      | DIMENSIONS INCH |       |       |
|        | MIN.                  | NOM. | MAX. | MIN.            | NOM.  | MAX.  |
| A      | 0.70                  | 0.75 | 0.80 | 0.027           | 0.029 | 0.031 |
| A3     | 0.200 REF             |      |      | 0.008 REF       |       |       |
| b      | 0.25                  | 0.30 | 0.35 | 0.010           | 0.012 | 0.014 |
| D      | 2.00 BSC              |      |      | 0.079 BSC       |       |       |
| D2     | 1.20                  | 1.30 | 1.40 | 0.046           | 0.050 | 0.054 |
| E      | 2.00 BSC              |      |      | 0.079 BSC       |       |       |
| E2     | 0.50                  | 0.60 | 0.70 | 0.022           | 0.024 | 0.026 |
| e      | 0.650 BSC             |      |      | 0.026 BSC       |       |       |
| L      | 0.25                  | 0.30 | 0.35 | 0.009           | 0.011 | 0.013 |

## Old Order, Mark & Packing Information

| No. of PIN | EN1 | EN2 | Package  | Marking           | Vout1 | Vout2 | Product ID        |
|------------|-----|-----|----------|-------------------|-------|-------|-------------------|
| 6          | Y   | Y   | SOT-23-6 | 3300<br>Date Code | 3.0   | 3.0   | EMP2033-00VC06GRR |
|            |     |     |          | 3301<br>Date Code | 1.8   | 3.0   | EMP2033-01VC06GRR |
|            |     |     |          | 3302<br>Date Code | 1.8   | 2.8   | EMP2033-02VC06GRR |
|            |     |     |          | 3303<br>Date Code | 2.5   | 3.3   | EMP2033-03VC06GRR |
|            |     |     |          | 3304<br>Date Code | 2.8   | 3.3   | EMP2033-04VC06GRR |
|            |     |     |          | 3305<br>Date Code | 1.8   | 3.3   | EMP2033-05VC06GRR |
|            |     |     |          | 3306<br>Date Code | 2.85  | 2.85  | EMP2033-06VC06GRR |

## Revision History

| Revision | Date       | Description   |
|----------|------------|---|
| 7.0      | 2009.04.03 | 1. Title<br>2. Ending<br>3. Order information<br>4. Add Revision History Form<br>5. Important Notice. |
| 7.1      | 2009.10.30 | 1. Update mark & packing information<br>2. Add NRR<br>3. Modify TDFN from 3x3 to 2x2                  |
| 7.2      | 2010.03.18 | Update P11 Bottom View Drawing  |

## Important Notice

All rights reserved.

No part of this document may be reproduced or duplicated in any form or by any means without the prior permission of ESMT.

The contents contained in this document are believed to be accurate at the time of publication. ESMT assumes no responsibility for any error in this document, and reserves the right to change the products or specification in this document without notice.

The information contained herein is presented only as a guide or examples for the application of our products. No responsibility is assumed by ESMT for any infringement of patents, copyrights, or other intellectual property rights of third parties which may result from its use. No license, either express, implied or otherwise, is granted under any patents, copyrights or other intellectual property rights of ESMT or others.

Any semiconductor devices may have inherently a certain rate of failure. To minimize risks associated with customer's application, adequate design and operating safeguards against injury, damage, or loss from such failure, should be provided by the customer when making application designs.

ESMT's products are not authorized for use in critical applications such as, but not limited to, life support devices or system, where failure or abnormal operation may directly affect human lives or cause physical injury or property damage. If products described here are to be used for such kinds of application, purchaser must do its own quality assurance testing appropriate to such applications.