

Bel Stewart  
Connector

May 1

2012

---

Network Connectors Interfaces and  
Differential to Common Mode Conversion

AN12012

# Network Connector Interfaces and Differential to Common Mode Conversion

## Abstract

The paper describes standard connector interfaces used in the networking including category 6a RJ45 and category 7a ARJ45. It discusses the differences between connectors within the networking equipment and premise wiring channels that share the same interface. The paper provides data for the Transverse Conversion Loss contribution of the interfaces within the twisted transmission media up to 2000 MHz.

The effects of the Differential to Common Mode Conversion (DCMC) on the network performance are discussed. The TCL can be reduced by utilizing a balanced RJ45 interface and further improved by utilizing a higher level category 7a interface. The Ethernet systems from 1 to 40 GbE shall benefit from the reduction of the TCL and corresponding common mode noise

## Internet over Copper Wire Channels

Close to 1 billion users are connected to the Internet today. Many of them are connected through copper-wire channels either leading to a final user or a part of the infrastructure. The Internet is built upon the standardized Ethernet protocols described in the IEEE 802.3 standards. The move toward the 40 and 100 GbE requires better and faster connectivity and lower noise.

The Ethernet signals utilize differential mode transmission. Each differential channel consists of two conductors, and requires a balance within the transmitter or receiving pair, or, in electrical terms, the characteristic impedance of each conductor within the channel shall be equal, typically 50 Ohm. If the balance is violated that results in transformation of a portion of the original signal energy into the parasitic common mode noise. The common mode conversion worsens the transmission by reducing the signal strength and adding to the noise.

In order to focus on the relation between the interfaces and DCMC we limit this discussion to the application spectra above 500 MHz.

## Interfaces and Connectors

The interface between a network appliance and the premise wiring is an interface between the building cabling infrastructure and equipment such as a switch or computer. For the user, it is simply a port where a patch cord is plugged into the network device. Unfortunately it is not simple. In fact, there are two networking interfaces, which have rather complex electrical and mechanical characteristics where the mechanical structures directly impact the transmission performance. The networking equipment connectors are not covered by the premise wiring standards.

The first interface is a connector; most often an RJ45 or ARJ45 (augmented RJ45). It is usually a receptacle (a jack) at the network appliance side, and a plug at the Premise Wiring cable side.

The first interface is the interruption and disturbance of the twisted pair media. The second interface is a transformer that provides a safety barrier between cables and a networking appliance. Often transformers, other magnetic elements and other signal conditioning components are incorporated into the connectors: such connectors are referred to as Integrated Connector Modules (ICM).

As a result, the connectors specified by TIA-568 series and ISO/IEC standards for the premise wiring have the same name as network equipment connectors but look and function differently. What they have in common are the interfaces.

The interface is subject to mechanical stresses and abuses. It is subject to electrical discharges due to connect and disconnect under the electrical load, in particular, in the Power-over-Ethernet (POE) applications.

And yet the interfaces have to be inexpensive and therefore not complex, must be robust and be easy to use by millions of people.

FIGURE 1 shows the most common connector interfaces for and applicable ISO/IEC standards. The jacks are shown. Table 1 lists the transmission classes and typical applications.

**Table 1. Transmission classes, categories and interfaces**

<b>Transmission class ISO/IEC standards</b>	<b>Connector category</b>	<b>Frequency bandwidth</b>	<b>Typical Application</b>	<b>Connecting Hardware Interface</b>
Class C	3	16 MHz	IEEE 802.5 TokenRing	RJ 45
Class D	5e	100 MHz	10 to 1000baseT Ethernet	RJ45
Class E	6	250 MHz	100-1000 baseT	RJ45
Class Ea	6a	500 MHz	1 to 10 GbE	RJ45,
Class F	7	600 MHz	1GbE over single pair 10 GbE	GG45, ARJ45
Class Fa	7a	1000 MHz	10 Gigabit over 2 pairs 10 GbE over 100 m	ARJ45,
NA	NA	2000 MHz	10 to 40 GbE	ARJ45

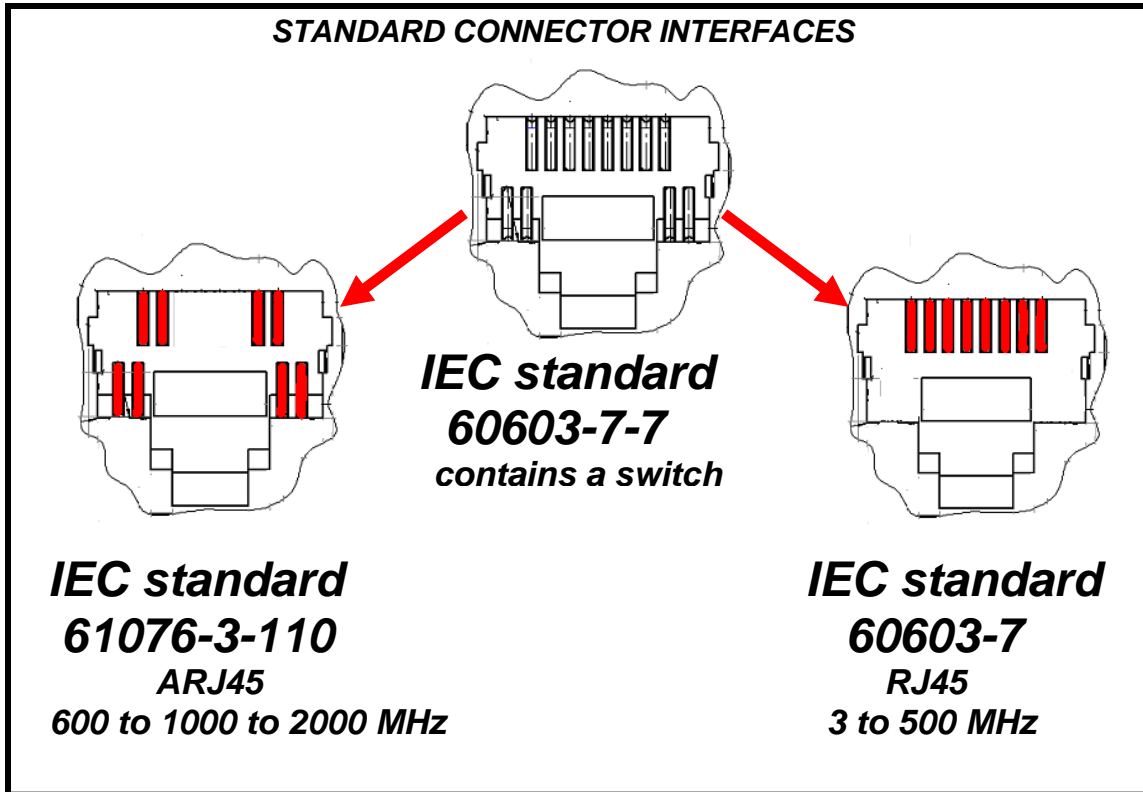

Figure 1. The connector interfaces and applicable international standards

The basic connector is a 12-contact category 7 connector described in the ISO/IEC 60603-7-7. Its opening's dimensions and contact positions were derived from the traditional RJ45 jack. The 8-contact RJ45 and AR45 connectors are its subsets. With an exception of the presence of bottom contacts all the dimensions of ARJ45 are identical to RJ45.

The category 7 connector has a mechanical switch inside that would redirect the signals from traditional split pairs 3/6 and 4/5 to new pairs located on the opposite side of the cavity.

A category 7 jack can accept either category 6a or lower RJ45 plugs or category 7a and 7a plugs. The same plug is used for category 7 and 7a connectors. This plug has a keying feature that prevents them from mating with Category 5e, 6 and 6a jacks. A category 7 and 7a plug has the front protrusion that activates a mechanical switch within the category 7 connector, shown in figure 2.

The same patch cord can have a category 6a plug on one side and a category 7a plug on another.

The category 7a connector ARJ45 (augmented RJ45) does not have any split pairs. An alternative category 7a connector that was not derived from the RJ45 interface is described by ISO 61076-3-114.

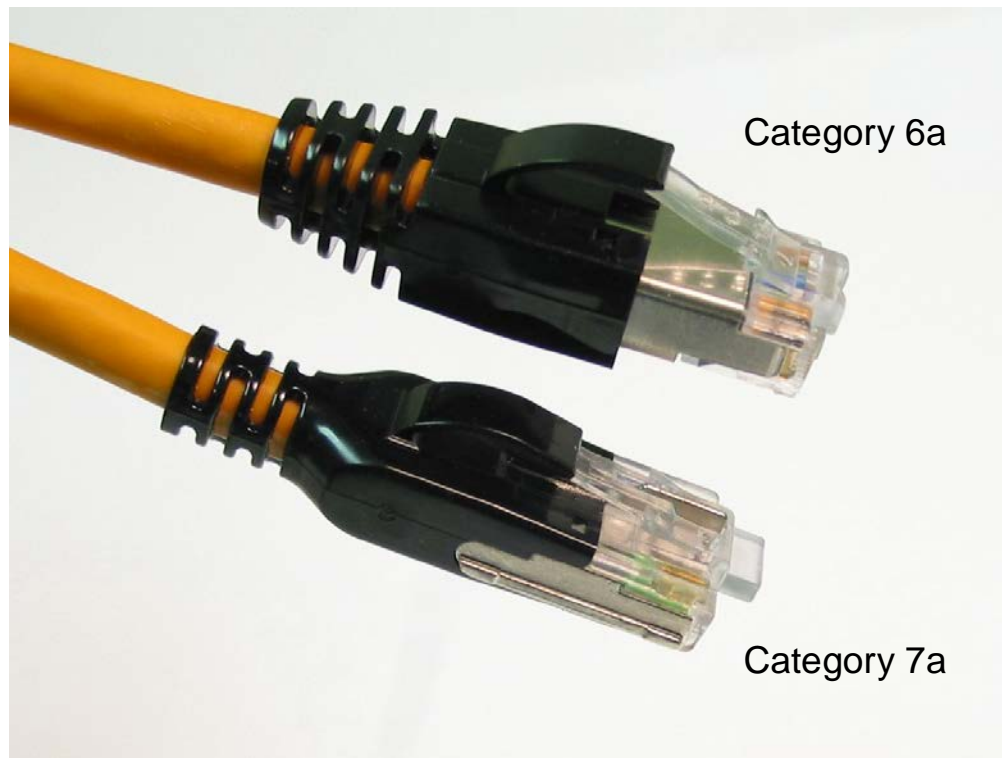

Figure 2. Category 7a to 6a plugs combined in a single patch cord

### **Compensation vs. Isolation**

#### ***The Major Difference between Category 7a and Lesser Categories.***

The major difference between RJ45 and ARJ45 connectors and interfaces is how the differential Near End Cross Talk is attenuated. That issue was one of the prime factors why the International Standards Organization decided to change to a new interface for applications above 500 MHz in the IEC/ISO standard 60603-7-7.

The RJ45 connector categories 5e to 6a use *compensation* to cancel the differential NEXT. The compensation is a method of purposefully creating the crosstalk in the near vicinity of the interface that is equal in amplitude but opposite in phase to the NEXT “native” to the interface. In practice, it calls for adding capacitive and some inductive elements and creating complex structures within the connectors. The compensation in the RJ45 connectors is used in both: shielded and unshielded designs.

The category 7a connectors rely on *isolation* to attenuate the NEXT. Category 7a connectors are always shielded. A Faraday cage is built around each differential pair that isolates them from each other, thus reducing NEXT. The ARJ45

interface design allows the isolation to be extended through a plug and a receptacle.

An additional and valuable benefit of an isolation method design is a dramatic improvement in the Transverse Conversion Loss in comparison to lesser interfaces.

### **Transverse Conversion Loss.**

The measure of the balance and Differential to Common Mode conversion applicable to the interface is described in the connecting hardware standards as the Transverse Conversion Loss (TCL), or Sdc11 as an S-parameter.

$$\text{TCL (dB)} = 20 \text{ LOG} \frac{\text{Common Mode Voltage}}{\text{Differential Mode Voltage}} \quad (\text{measured at the same end})$$

It is useful to keep in mind that TCL is the measure of the quality of the interface as a source of common mode.

**Table 2. TCL in the standards**

	<b>Expression</b>	<b>Frequency Range, MHz</b>
TIA	28-20Log (f/100)	1 to 500
ISO/IEC	68-20 Log(f)	1 to 1000

Both standard expressions yield the same values shown in table 3 below.

**Table 3. TCL values (dB) as specified in the IEC/ISO standards**

Frequency	TCL
MHz	dB
1	68.0
10	48.0
50	34.0
100	28.0
150	24.5
200	22.0
250	20.0
300	18.5
400	16.0
500	14.0
600	12.4
700	11.1
800	9.9
900	8.9
1000	8.0

### **Balanced Twisted Pair Environment**

Outside the connector contacts proper, that form the mechanical interface, the regions directly adjacent to the interface are twisted pairs.

On one side it is a patch cord, on another side it is a high performance LAN transformer. The transformer windings made of twisted pairs are shown in Figure 3



**Figure 3. High Performance 10GbE LAN transformer utilizes twisted pairs**

The differential pairs of the high performance 10GbE LAN transformer winding are twisted. In addition to reducing the inter-winding capacitance which is always parasitic, the twisting directly improves the DCMC. Also, the highest performing LAN magnetics both chokes and transformers tend to use a controlled media, such as ferrite, on all sides of the channels within the windings.

The impedance of a balanced twisted pair is derived from the impedances of two conductors, as shown in figure 4. The differential impedance in this case does not have a resistive component and consists of the inductance and capacitance.

$$Z_1 = Z_2 \quad \text{and} \quad Z_d = Z_1 + Z_2$$

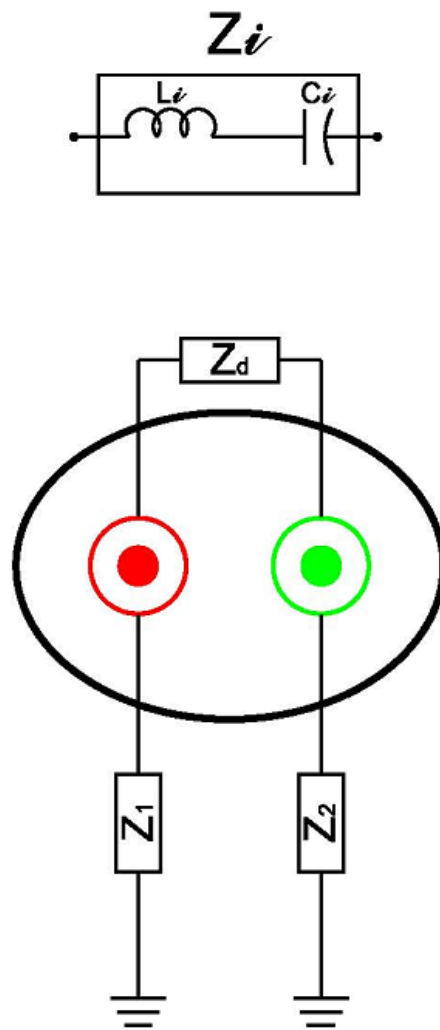

Figure 4. Differential Impedance of a balanced twisted pair



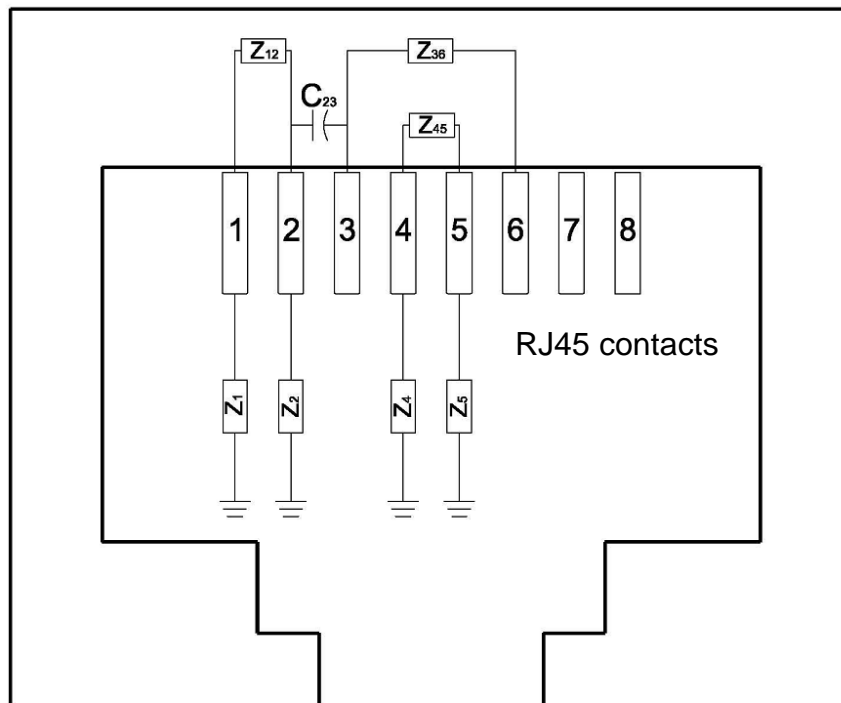

Figure 5. INTERFACE GEOMETRY vs. ELECTRICAL STRUCTURE

The prime source of TCL is change in the geometry defining the characteristic impedance on the interface. Compare figures 4 and 5. The Figure 5 is an electrical structure of RJ45 - one the most popular connector in the world where differential pairs defined as contacts 1-2, 3-6, 4-5, 7-8.

The positions of the contacts in the RJ45 interface are such as there is explicit imbalance. The pair 45 is intrinsically better balanced as well as 36, though their impedance is hard to match to each other. The intra-pair balance of differential pairs 1-2 and 7-8 are affected by their positions where contacts 2 and 7 capacitively coupled to adjacent contacts, and

$$Z_1 \neq Z_2$$

The result is a skew and the degradation of the TCL.

There are other sources of imbalance. All category 6a connectors are supposed to meet the minimum TCL requirements. Within the plug the patch cord is changed from the twisted to the interface geometry. The balanced plug incorporates the design where at least a portion of the transmission channel within the plug is balanced or controlled. The technology, sometimes referred to as a *wire guide filter*, in which pairs are guided through the plug to mimic the balance of a twisted pair cable.

Thus, within the Category 6a connectivity there are subsets of balanced and unbalanced connectors.

The category 7a connectors maintain the balance and low TCL to the spectra well above 1000 MHz

### Negative Effects of High TCL

The high TCL causes greater common mode noise. The common mode noise reduces the signal energy. The common mode signal generally has a different propagation velocity from the differential signal. It also has an arbitrary phase.

Two common noise signals can form an effectively parasitic differential signal superimposed on the original useful transmission. The common noise causes EMI and jitter. As a contributor to the Alien NEXT it may cause bit errors.

The shorter the channel length the greater are negative effects of the TCL

The reduction in the TCL and corresponding DCMC is translated in a lower noise and potential increases in the useful channel length.

The direct contribution of the TCL to the channel length heavily depends on the cable quality, specifically the cable's insertion loss. Though the experimental evaluation is still in progress, the estimated improvement in length due to 10 dB reduction in the TCL can be as high as 10m for 500 MHz applications

### Transverse Conversion Loss: Comparative Test Data

The computer modeling conducted by Bel's R&D, using the coaxial structures, established a theoretical limit for Sdc11 as 98 dB at 1000 MHz.

Table 4 provides a comparison of the TCL values for balanced and unbalanced category 6a connectors and category 7a ARJ45 connectors. The TCL limit is used instead of data of unbalanced Category 6a connectors.

Table 4. Test data: selected (worst) TCL values of Network Connectors, dB

Frequency, MHz	Category 6a		Category 7a
	unbalanced	balanced	
	RJ45	RJ45	ARJ45
50	34	45	58
100	28	40	53
250	20	32	56
500	14	26	42
1000	-	16	31
2000	---	14	19

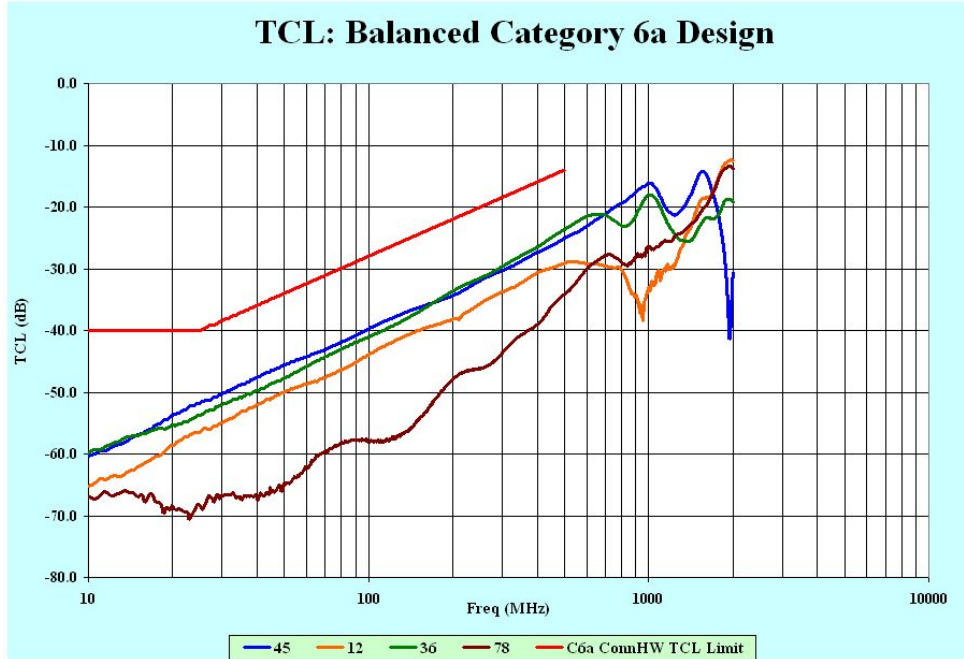

Figure 6. TCL of balanced category 6a connector with a Wire Guide Filter

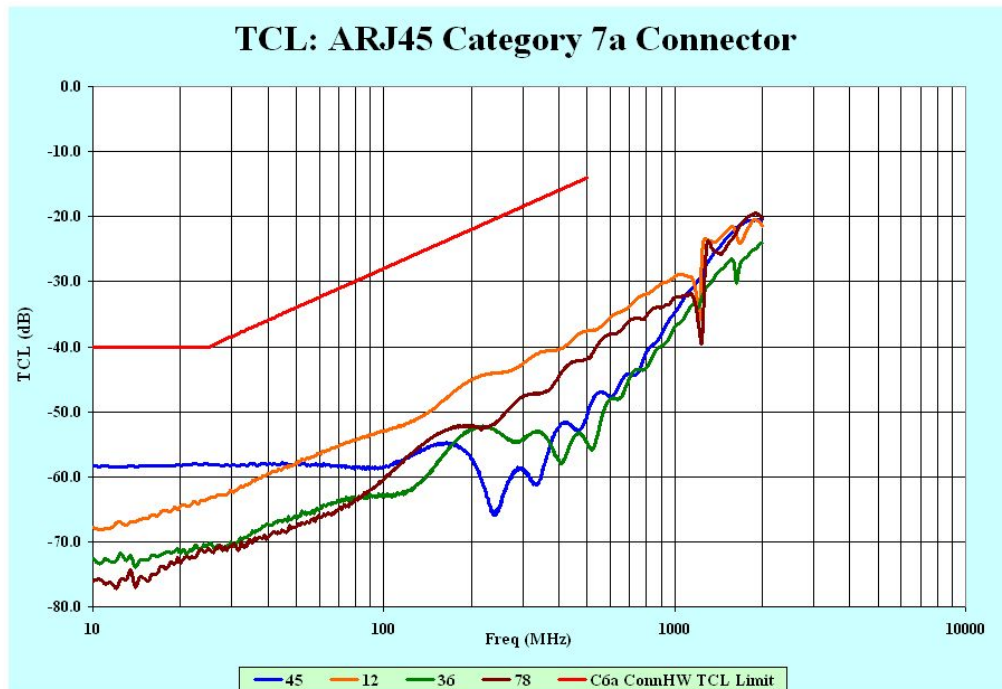

Figure 7 TCL of category 7a ARJ45 connector

## Summary

The Transverse Conversion Loss defines the interface as a source of Differential to Common Mode Conversion. The common mode noise negatively affects the network transmission. The Internet traffic from 1 GbE to 10 GbE and, in particular, new 40 GbE systems should benefit from balanced category 6a connectors. In the frequency spectra above 500 MHz the category 7a connectors can provide improvement of over 15 dB in comparison to category 6a and extend the channel bandwidth to 2000 MHz and above

## Authors

**Yakov Belopolsky**, Manager, Research & Development, Member of the US TAG and a member of the ISO/IEC committees on Connectors and Cabling.  
Yakov published over 30 technical papers and awarded 78 US patents.

**Rich Marowsky**, Principal Electrical Engineer, Member of the TIA committees.  
Rich has over 35 years experience in Development, Simulation, and Testing High Speed Connector Products for Computer Systems and the Premise Wire Industry

Bel Stewart Connector, Glen Rock, PA , USA