

# LRD 01...35

**3-pole Thermal Overload Relays**  
**Use in Explosive Atmospheres**

**CE 0080** **Ex II (2) GD - Zones 1 - 2, 21 - 22**  
**EC type examination certificate:**  
**INERIS 06ATEX0036X**

## Description



LRD 21

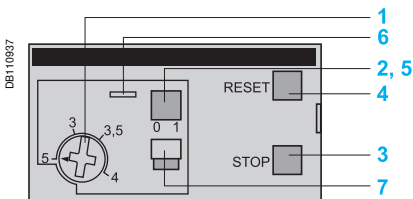

LRD01 to LRD35 3-pole thermal overload relays are designed to protect a.c. circuits and motors against overloads, phase failure, long starting times and prolonged stalling of the motor.

- 1 Adjustment dial I<sub>r</sub>.
- 2 Test button.  
Operation of the Test button allows:
  - checking of control circuit wiring,
  - simulation of relay tripping (actuates both the N/O and N/C contacts).
- 3 Stop button. Actuates the N/C contact; does not affect the N/O contact.
- 4 Reset button.
- 5 Trip indicator.
- 6 Setting locked by sealing the cover.
- 7 Selector for manual or automatic reset. Relays LRD 01 to 35 are supplied with the selector in the manual position, protected by a cover. Deliberate action is required to move it to the automatic position.

## Environment

<b>Conforming to standards</b>		IEC 60947-1, IEC 60947-4-1, NF C 63-650 VDE 0660, BS 4941
<b>Product certifications</b>		CSA, UL, Sichere Trennung, ATEX except LAD 4: UL, CSA.
<b>Degree of protection</b>	Conforming to VDE 0106	Protection against direct finger contact IP 2X
<b>Protective treatment</b>	Conforming to IEC 60068	"TH"
<b>Ambient air temperature around the device</b>	Storage	°C - 60...+ 70
	Normal operation, without derating (IEC 60947-4-1)	°C - 20...+ 60
	Minimum and maximum operating temperatures (with derating)	°C - 40...+ 70
<b>Operating positions without derating</b>	In relation to normal vertical mounting plane	Any position
<b>Shock resistance</b>	Permissible acceleration conforming to IEC 60068-2-7	15 gn - 11 ms
<b>Vibration resistance</b>	Permissible acceleration conforming to IEC 60068-2-6	6 gn
<b>Dielectric strength at 50 Hz</b>	Conforming to IEC 60255-5	<b>kV</b> 6
<b>Surge withstand</b>	Conforming to IEC 60801-5	<b>kV</b> 6

## Electrical characteristics of power circuit

Relay type		LRD 01...16, LR3 D01...D16	LRD 21...35, LR3 D21...D35
<b>Tripping class</b>	Conforming to UL 508, IEC 60947-4-1	10 A	10 A
<b>Rated insulation voltage (U<sub>i</sub>)</b>	Conforming to IEC 60947-4-1	<b>V</b> 690	690
	Conforming to UL, CSA	<b>V</b> 600	600
<b>Rated impulse withstand voltage (U<sub>imp</sub>)</b>		<b>kV</b> 6	6
<b>Frequency limits</b>	Of the operating current	<b>Hz</b> 0...400	0...400
<b>Setting range</b>	Depending on model	<b>A</b> 0,1...13	12...38

## Electrical characteristics of auxiliary contacts

Conventional thermal current		<b>A</b> 5						
<b>Maximum sealed current</b> consumption of the operating coils of controlled contactors (Occasional operating cycles of contact 95-96)	a.c. supply	<b>V</b> 24	48	110	220	380	600	
		<b>VA</b> 100	200	400	600	600	600	
	d.c. supply	<b>V</b> 24	48	110	220	440	—	
		<b>W</b> 100	100	50	45	25	—	
<b>Short-circuit protection</b>	By gG or BS fuses or by circuit-breaker <b>GB2</b>	<b>A</b> 5						

# LRD 01...35

3-pole Thermal Overload Relays  
Use in Explosive Atmospheres



II (2) GD - Zones 1 - 2, 21 - 22

EC type examination certificate:  
INERIS 06ATEX0036X

## Operating characteristics

Relay type		LRD 01...16, LR3 D01...D16	LRD 21...35, LR3 D21...D35
Temperature compensation	°C	- 20...+ 60	- 30...+ 60
Tripping threshold	Conforming to IEC 60947-4-1	A	
		1,14 ± 0,06 I <sub>n</sub>	
Sensitivity to phase failure	Conforming to IEC 60947-4-1	Tripping current 30 % of I <sub>n</sub> on one phase, the others at I <sub>n</sub>	

## Tripping curves

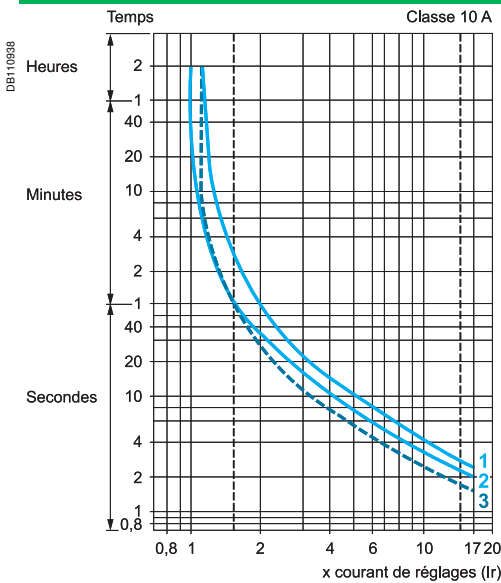

### Average operating times related to multiples of the setting current

- 1 Balanced operation, 3-phase, from cold state.
- 2 2-phase operation, from cold state.
- 3 Balanced operation, 3-phase, after a long period at the set current (hot state).

## Differential thermal overload relays for use with fuses

Class 10 A (1) with connection by screw clamp terminals or connectors

- Compensated relays with manual or automatic reset,
- with relay trip indicator,
- for a.c. or d.c.

Relay setting range (A)	Fuses to be used with selected relay			For use with contactor LC1	Reference	Weight kg
	aM (A)	gG (A)	BS88 (A)			
0,10...0,16	0,25	2	—	D09...D38	LRD 01	0,124
0,16...0,25	0,5	2	—	D09...D38	LRD 02	0,124
0,25...0,40	1	2	—	D09...D38	LRD 03	0,124
0,40...0,63	1	2	—	D09...D38	LRD 04	0,124
0,63...1	2	4	—	D09...D38	LRD 05	0,124
1...1,6	2	4	6	D09...D38	LRD 06	0,124
1,6...2,5	4	6	10	D09...D38	LRD 07	0,124
2,5...4	6	10	16	D09...D38	LRD 08	0,124
4...6	8	16	16	D09...D38	LRD 10	0,124
5,5...8	12	20	20	D09...D38	LRD 12	0,124
7...10	12	20	20	D09...D38	LRD 14	0,124
9...13	16	25	25	D12...D38	LRD 16	0,124
12...18	20	35	32	D18...D38	LRD 21	0,124
16...24	25	50	50	D25...D38	LRD 22	0,124
23...32	40	63	63	D25...D38	LRD 32	0,124
30...38	40	80	80	D32 and D38	LRD 35	0,124

(1) Standard IEC 60947-4-1 specifies a tripping time for 7.2 times the setting current I<sub>R</sub>: class 10 A: between 2 and 10 seconds.

# LRD 01...35

3-pole Thermal Overload Relays  
Use in Explosive Atmospheres

CE 0080  $\text{Ex}$  II (2) GD - Zones 1 - 2, 21 - 22  
EC type examination certificate:  
INERIS 06ATEX0036X

## General rules for us

**These products MUST be installed outside ATEX zones.**

They are qualified for the protection of motors that are protected against explosions and placed in zones 1-2 or 21-22.

**Use of these products must be limited to the electric motor control function for which they are designed.**

These products must be installed, used and maintained in accordance with the standards and regulations applicable within the country of installation, for example:

- Directive 99/92/EC
- Standards IEC 60079-17 and IEC 60364
- Established practice for installation in the zone or zones for which they have been designed.

We accept no responsibility in the event of failure to comply with these standards and regulations. This product must be installed, started up and maintained by qualified, authorized personnel.

**Responsibility for manufacturer's traceability (serial number on the certification label) is at the first known delivery location.**

### Startup:

- Before startup, check that the product has not been damaged (do not use a product if it is damaged).
- Check that the information marked on the product is compatible with the permitted conditions for the Ex zone of the site in which it is to be used (**Group II**: Surface industries - **Category 2**: high protection level - **D**: Dust - **G**: Gas).
- Store the products in their original packaging, in a dry place, T: -60°... +70°C.
- On startup: connect, assemble and adjust in accordance with the manufacturer's instructions.

## Dimensions

Direct mounting beneath contactors with screw clamp connections

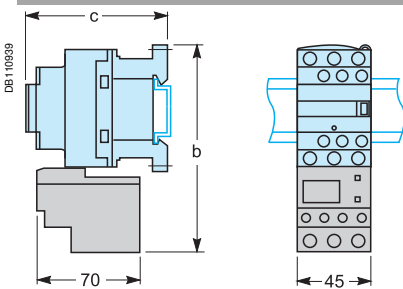

LC1	D09...D18	D25...D38
-----	-----------	-----------

b	123	137
---	-----	-----

c (LC1 D without cover or add-on blocks)	84	90
--	----	----

Independent mounting on 50 mm centres or on rail AM1 DP200 or DE200

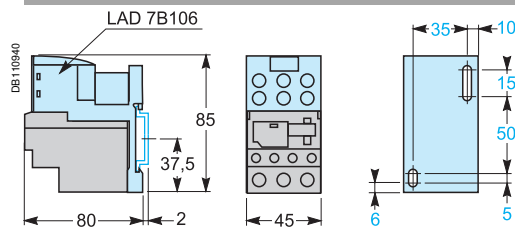

Independent mounting on 110 mm centres

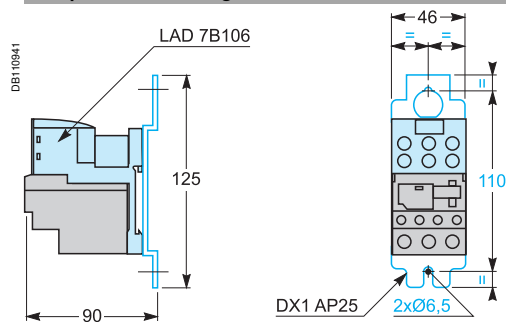

### ⚠ DANGER

**HAZARD OF ELECTRIC SHOCK, EXPLOSION, OR ARC FLASH**

Disconnect all power before servicing equipment.

**Failure to follow these instructions will result in death or serious injury.**

## Connection

Connection accessories

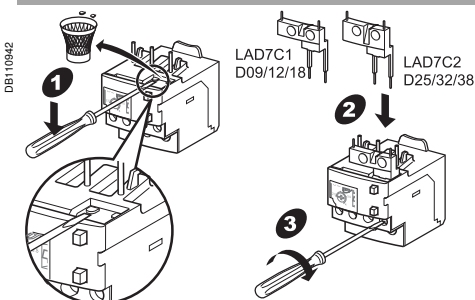

With LC1 D contactor

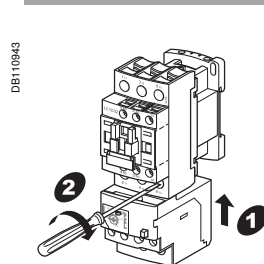

On LAD 7B106

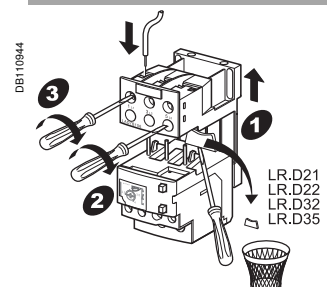

# LRD 01...35

3-pole Thermal Overload Relays  
Use in Explosive Atmospheres

CE 0080  $\text{Ex}$  II (2) GD - Zones 1 - 2, 21 - 22

EC type examination certificate:  
INERIS 06ATEX0036X

## Connection

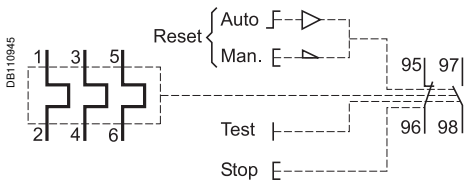

### Power circuit

	mm	mm <sup>2</sup>	mm <sup>2</sup>	mm <sup>2</sup>	Nm	mm
LRD 01...21 LR3 D01...D21	10	1...6	1,5...6	1...4	1,7	Ø2
LRD 22...35 LR3 D22...D35	10	2,5...10	2,5...10	1,5...6	2,5	Ø2

### Auxiliary contacts

	mm	mm <sup>2</sup>	mm <sup>2</sup>	mm <sup>2</sup>	Nm	mm
	8	1...2,5	1...2,5	1...2,5	1,7	Ø2

## Setting and test

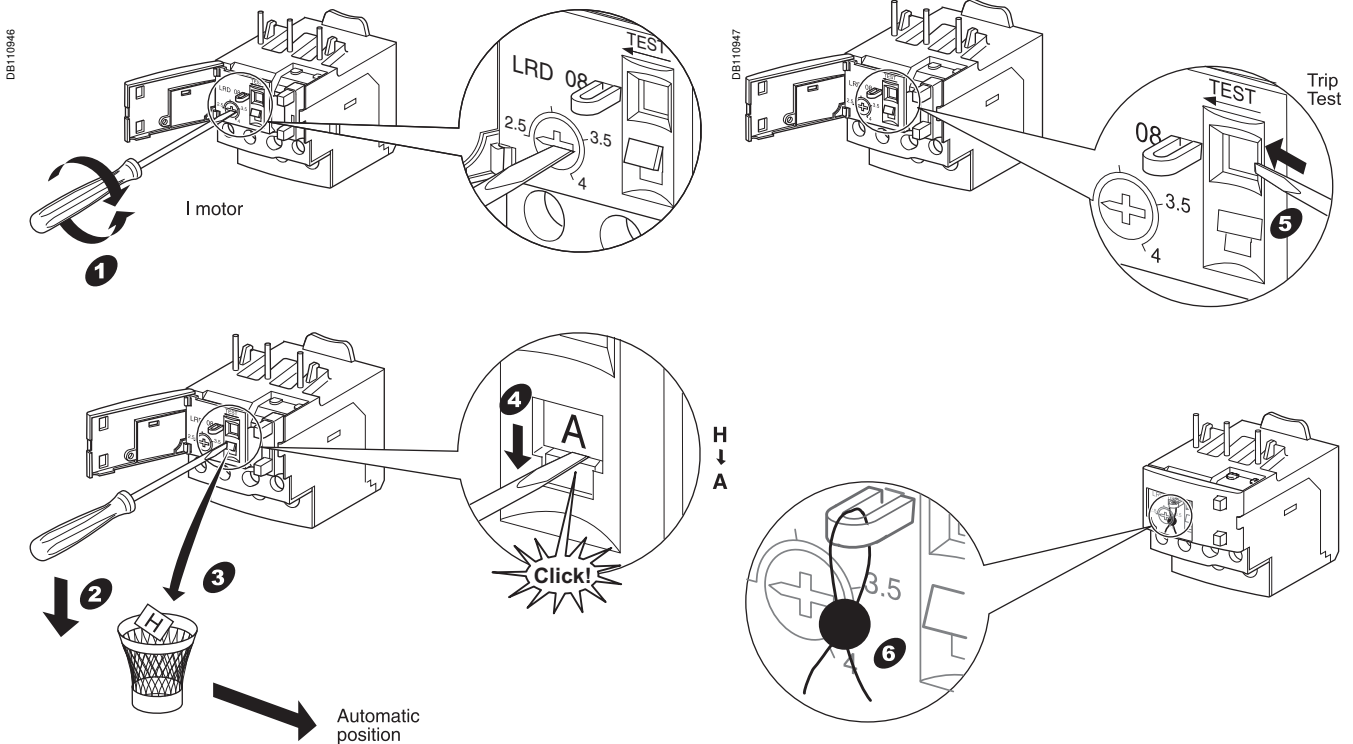

## Maintenance

In accordance with the maintenance rules for all electrical installations, check the following once a year:

- The correct tightening of the cables, by re-tightening all the connections
- The mechanical operation of the product, by manually operating the test button.

Schneider Electric Industries SAS

35, rue Joseph Monier  
92500 Rueil-Malmaison  
France  
<http://www.schneider-electric.com>

Due to possible changes in standards and equipment, the features described in this document in the form of the text and images are subject to confirmation by Schneider Electric.