

Specification



Model: JD102MLXD

VER:2.00-AT070TN92

USER			MANUFACTURER		
QA	Project	Approved by	Prepared by	Checked by	Approved by

Catalogue

Content	2
Version	3
1. Profile	4
2. Application	4
3. Main Parameter	4
4. Block Diagram , Product Picture	5
5. Wiring Diagram	6
6. Connection Definition of Driver Board	6-11
7. Structural Diagram	12-13
8. 7" TFT- LCD Panel Inspection Standard	14-15
9. Packing	16
10. Attention	16

1.Profile :

JD102MLXD Ver:2.00-AT070TN92 Color TFT LCD Module is composed by JD102MLXD Driver Board Ver:2.00 and 7" Innolux AT070TN92 V.1 Digital Panel. The Module has VIDEO, AUDIO & VGA signal input, it adopts the backlight of LED, Two system formats, PAL and NTSC (auto switch). also has OSD and IR receipt function.

2. Application:

This module applies for as follows :

- Office electronic equipment
- Instrument and Measure appliance
- Machinery and Equipment
- Audiovisual (Car Monitor、 Portable DVD、 Long-distance terminal player、 LCD Player)
- Household (Video door phone、 LCD advertising player、 display for machine、 medical player)

2. Main Parameters :

- Product name : 7" TFT-LCD digital module
- Product Model : JD102MLXD VER:2.00-AT070TN92
- Display Panel : 7" TFT-LCD (Innolux Digital Panel;16:9)
- Backlight : LED
- Pixel resolution : 800 (H) × 3RGB × 480 (V)
- View angle Ø (U/D/L/R) : (45/65/65/65)
- Brightness : 250 cd/m²
- System format : PAL/NTSC automatically switch
- Video input : 1.0Vp-p 75 ohm
- Power Supply Input : DC 12V ±25% 340mA±30mA
- Panel display dimension(mm) : 154.08 (H) x 85.92 (V)
- Panel Overall dimension(mm) : 164.9 (W) x 100 (H) x 5.7 (D)
- Structural dimension of PCB without VGA socket (mm) : 128.8(W) x 85.4(H) x 6.7(D)
- Structural dimension of pushbutton board(mm): 62(W) x 15.6 (H) x 7.2 (D)
- Working temperature : -10 ~60
- Environmental relative humidity : 5~95% RH
- Storage temperature : -20 ~+70

4. Block Diagram:

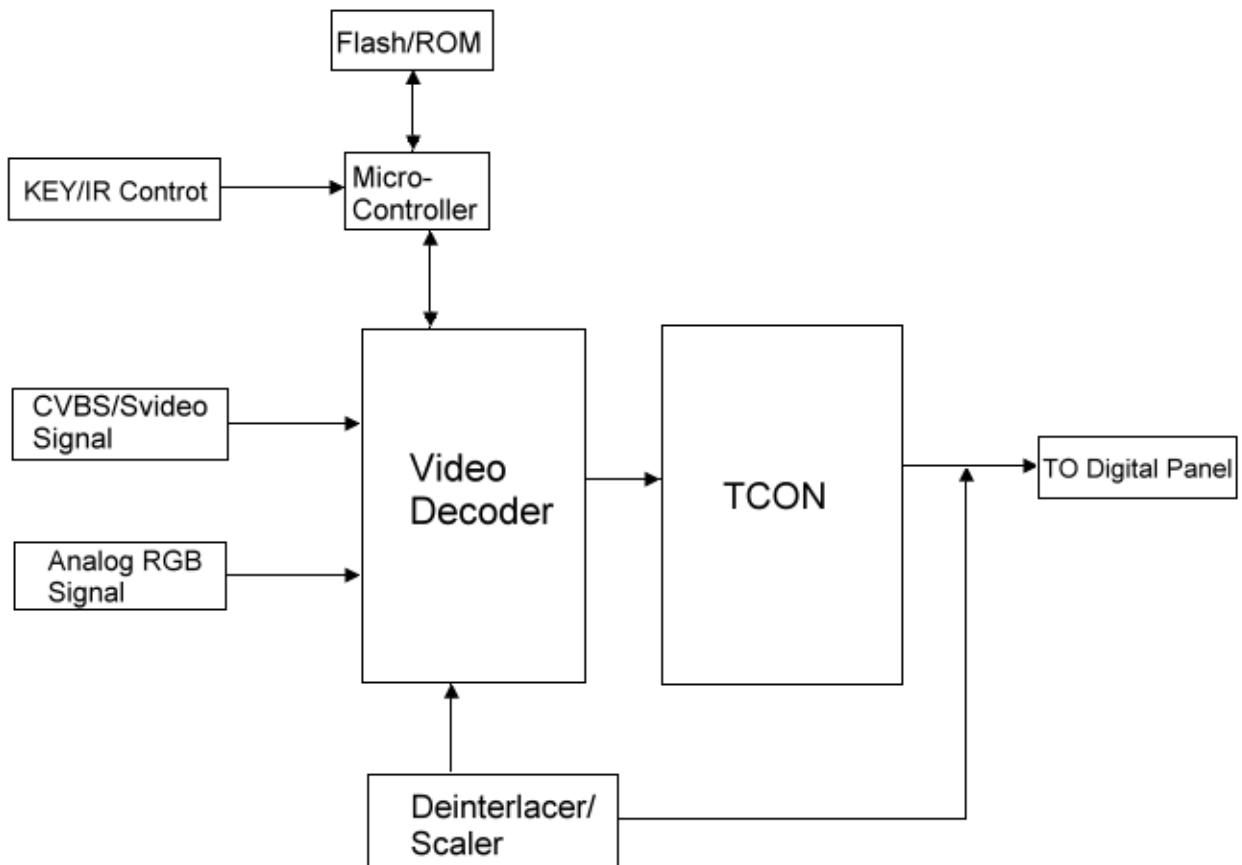

Product Picture:



5. Wiring diagram:

5.1 Driver board's wiring diagram:

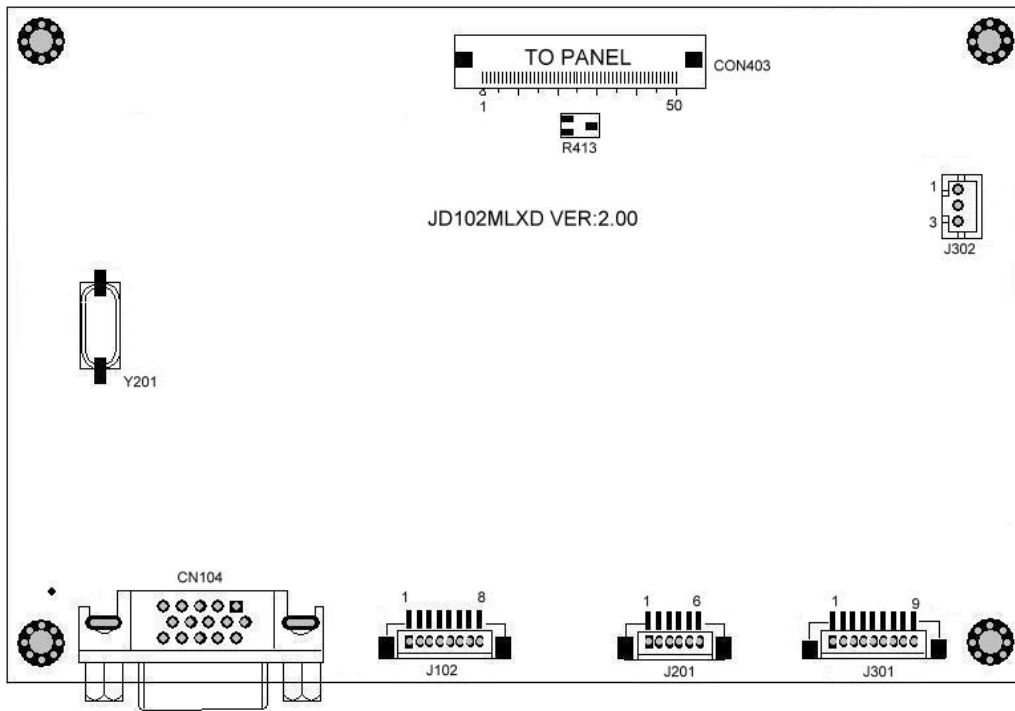

5.2 Key-board:



The definition of key-press:

Pin No.	Symbol	Input/Output	Definition	Remark
SW4	SOURCE	I	AV Switch	
SW5	POWER	I		
SW6	MENU	I		
SW7	+	I	Up	
SW8	-	I	Down	

Menu key(SW6) display:

PICTURE



6. Connector Definition of Driver Board:

6.1 The Connector Definition of J201:

Pin No.	Symbol	Input/Output	J201 Description	Remark
1	+5V	O	+5V Power output	
2	GND	-	Ground	
3	IR	I	Remote control input	
4	SAR0	I	Key-board input 0 group	
5	SAR1	I	Key-board input 1 group	
6	NC	-	Empty	

6.2 The Definition of J102(Video, Power Supply input):

Pin No.	Symbol	Input/Output	Description	Remark
1	+12V	I	+12V power input	
2	+12V	I	+12V power input	
3	GND	-	Ground	
4	GND	-	Ground	
5	Video	I	Video Input	
6	C	I	C Signal Input	
7	Y	I	Y Signal Input	
8	GND	-	Ground	

6.3 The Connector Definition of J301(Audio Input):

Pin No.	Symbol	Input/Output	Description	Remark
1	GND	-	Ground	
2	VGA-L	I	VGA Audio Left	
3	VGA-R	I	VGA Audio Right	
4	GND	-	Ground	
5	CVBS-L	I	CVBS Audio Left	
6	CVBS-R	I	CVBS Audio Right	
7	GND	-	Ground	
8	Y/C-L	I	Y/C Audio Left	
9	Y/C-R	I	Y/C Audio Right	

6.4 VGA Connector Definition of CN104:

Pin No.	Symbol	Input/Output	Description	Remark
1	RED	I		

2	GREEN	I		
3	BLUE	I		
4	NC	-	Empty	
5	GND	-		
6	GND	-		
7	GND	-		
8	GND	-		
9	NC	-		
10	NC	-		
11	NC	-		
12	NC	-		
13	HSYNC	I		
14	VSYNC	I		
15	NC	-		

6.5 The connector definition of J302(Left, Right Track Output):

Pin No.	Symbol	Input/Output	Description	Remark
1	LOUT	O	Left Track Output	
2	GND	-	Ground	
3	ROUT	O	Right Track Output	

6.6 The Connector Definition of CON403:

Pin No.	Symbol	I/O	Function	Remark
1	LED +	P	LED Anode	
2	LED +	P	LED Anode	
3	LED -	P	LED Cathode	
4	LED -	P	LED Cathode	
5	GND	P	Power ground	
6	VCOM	I	Common voltage	

7	VCC	P	Power for Digital circuit	
8	MODE	I	DE/SYNC mode select	Note3
9	DE	I	Data Input Enable	
10	VS	I	Vertical Sync Input	
11	HS	I	Horizontal Sync Input	
12	B7	I	Blue data(MSB)	
13	B6	I	Blue data	
14	B5	I	Blue data	
15	B4	I	Blue data	
16	B3	I	Blue data	
17	B2	I	Blue data	
18	B1	I	Blue data	
19	B0	I	Blue data(LSB)	
20	G7	I	Green data (MSB)	
21	G6	I	Green data	
22	G5	I	Green data	
23	G4	I	Green data	
24	G3	I	Green data	
25	G2	I	Green data	
26	G1	I	Green data	
27	G0	I	Green data (LSB)	
28	R7	I	Red data (MSB)	
29	R6	I	Red data	
30	R5	I	Red data	
31	R4	I	Red data	
32	R3	I	Red data	
33	R2	I	Red data	
34	R1	I	Red data	
35	R0	I	Red data (LSB)	
36	GND	P	Power ground	
37	DCLK	I	Sample clock	
38	GND	P	Power ground	
39	L/R	I	Right/ left selection	Note2,5
40	U/D	I	Up/down selection	Note2,5
41	VGH	P	Gate ON voltage	
42	VGL	P	Gate OFF voltage	

43	AVDD	P	Power for Analog circuit	
44	RESET	I	Global reset pin.	Note1
45	NC	-	No connection	
46	VCOM	I	Common voltage	
47	DITHB	I	Dithering function	Note 4
48	GND	P	Power ground	
49	NC	-	No connection	
50	NC	-	No connection	

7.Structural Diagram :

7.1 LCD panel :

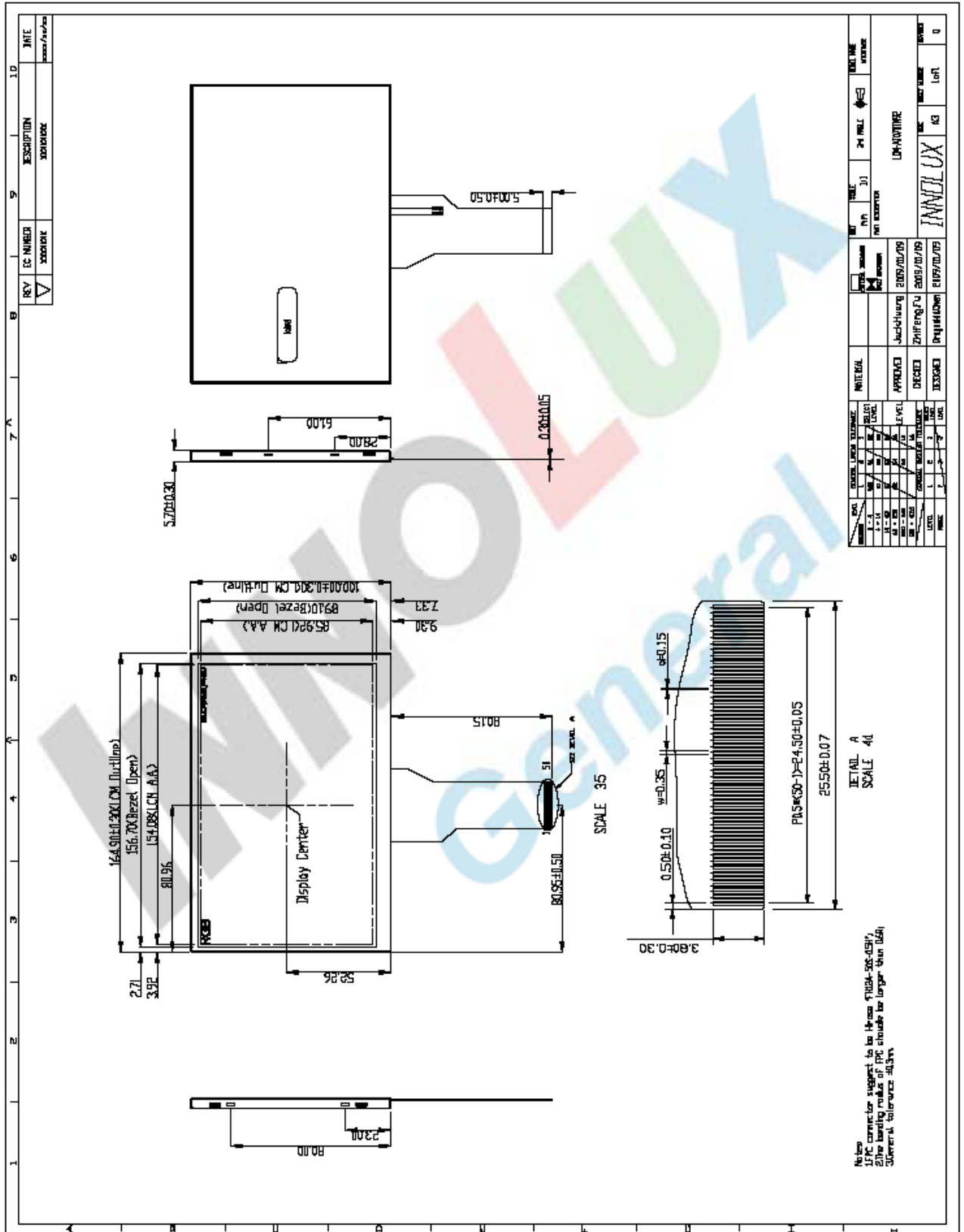

7.2 PCB:

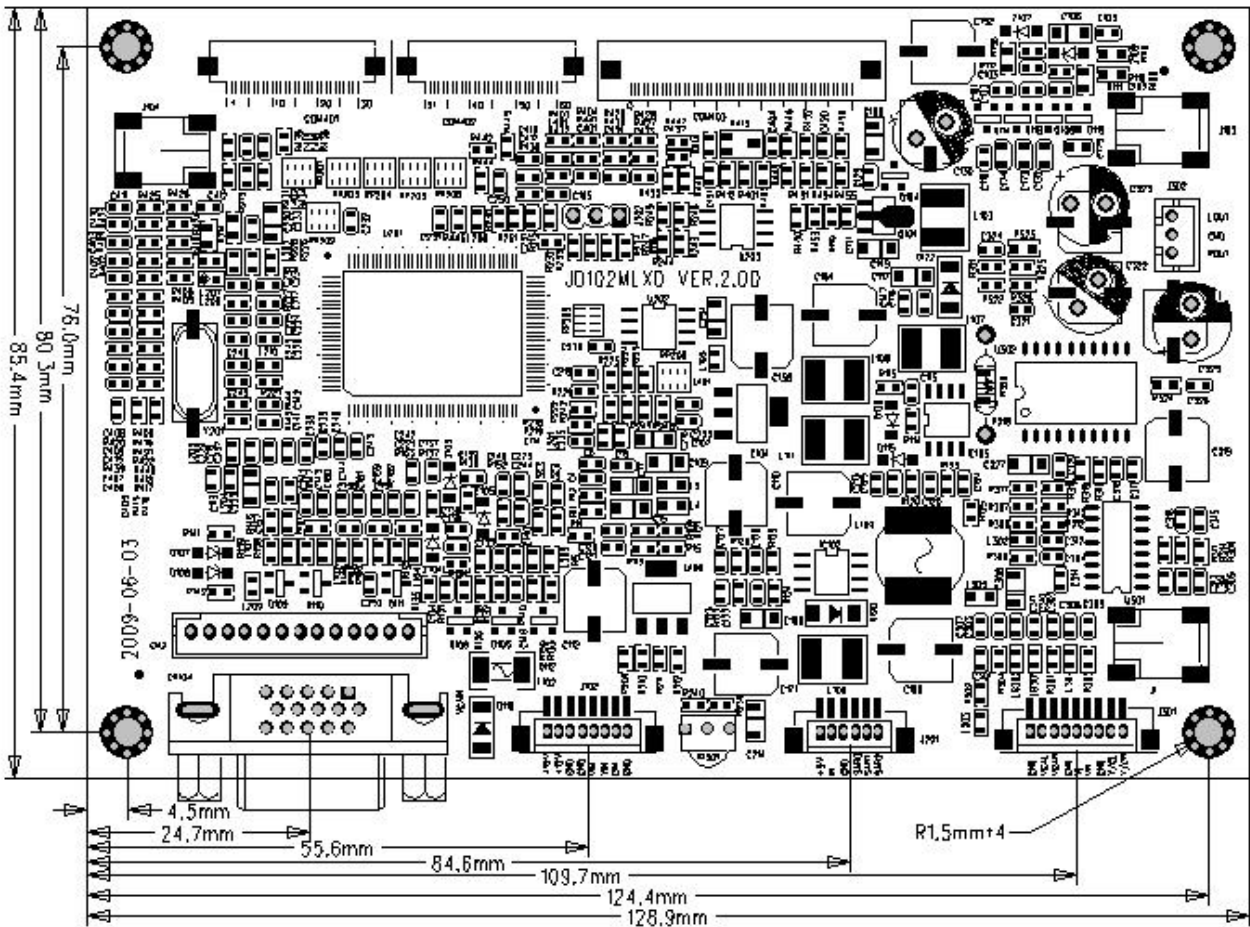

With VGA Connector:

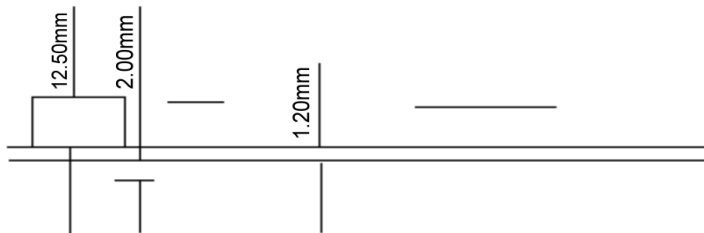

Without VGA Connector:

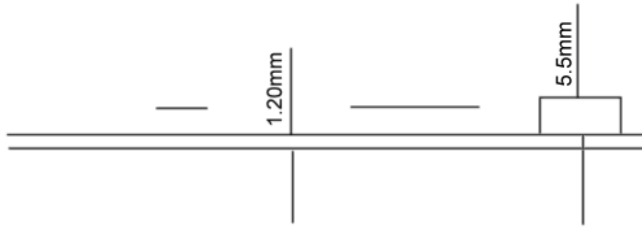

8. 7" TFT- LCD PANEL determinant standard:

Aim : Establishing the standard of PANLE for inspecting material & progress and for clients' inspection.

Scope : Apply to 7" TFT LCD

Content :

8.1. Inspection standard and method :

8.1.1. The method and determinant of inspecting the nick of panel of LCD :

8.1.1.1. Inspect vertically (or at 45 ° angle from left/right) under the light tube (the power is 20 W) in the distance of 30cm to the panel. If there is no nick , it is "OK". Otherwise "NG".

8.1.2. The method and determinative for black & white & color spots for the Panel of LCD :

8.1.2.1. Inspection methods

8.1.2.1.1. Black spots : under status of denote light , set the MASK of black spot inspection near the black spot then compare the big and small by eyes.

8.1.2.1.2. White & Color spots: under status of denote light, set the Mask of black spot inspection on the white spot(or color spot) then inspect them by eyes if it can hide.

8.1.2.2. Division of LCD Panel

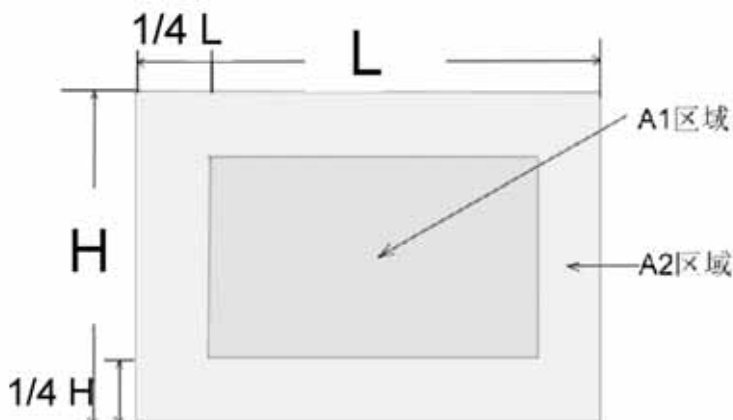

Remark : A1 : The center of the available area for the picture

A2 : The edge of the available area for the picture (around the central area)

8.1.3. Determinant Choice

Spot Diameter (mm)		Allowed Area	
		A1	A2
Black Spot	$d \leq 0.15$	Irrespective	Irrespective
	$0.15 < d \leq 0.3$	4	4
	$0.3 < d \leq 0.5$	2	3
	$0.5 < d \leq 0.8$	0	2
White or color spot	$d \leq 0.15$	Irrespective	Irrespective
	$0.15 < d \leq 0.3$	3	3
	$0.3 < d \leq 0.5$	1	2
	$0.5 < d \leq 0.8$	0	1

- Remark: 1. Size: Average Diameter= (Max. Diameter + Min. Diameter) /2
 2. Using information above as a standard in order to judge while the spot is are dense.
 3. Black & White spot : To judge the obvious spots through the change of voltage by comparison.
 4. Total quantity of Black & white & color spot: A1+A2 4.

9. Packing

TBD

10. Attention:

1. Voltage don't exceed upper limit.
2. The connector can't connect board in reverse, or will burn the board and influence the product.
3. Please don't touch it in order to keep your skin non-burn when you electrify the board(high voltage on the board).
4. It is a electronic product, so you need to take anti-static measure when you operate it.
5. 7" TFT-LCD panel is a glasswork, place carefully ,broken for fear.
6. The connection is "FPC", which connect 7"TFT-LCD panel with PCB, Please operate it carefully, in order to keep it well.
7. Don't touch key-press's pin when you adjust brightness, color through soft key-press, due to Person have resistance, you will effect image's impact when touch it.