

TE Circuit Protection 5mm 2Pole GDTs (ceramic gas discharge tubes), are commonly used to help protect sensitive telecom equipment such as communication lines, signal lines and data transmission lines from damage caused by transient surge voltages that typically result from lightning strikes and equipment switching operations.

Raychem Circuit Protection GDTs offer a high level of surge protection, low capacitance and a broad array of breakover voltage levels, making them suitable for applications such as MDF (Main Distribution Frame) modules, high data-rate telecom applications (e.g. ADSL, VDSL), and surge protection on power lines. Raychem Circuit Protection GDTs, can help equipment meet the most stringent regulatory standards.

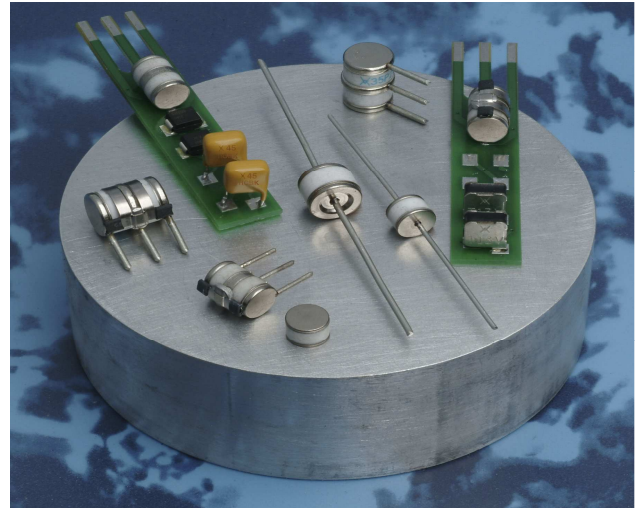

Benefits:

- Compact, small form factor suitable for efficient assembly
- Helps provide overvoltage fault protection against high energy surges
- Suitable for high-frequency applications

Features:

- 2Pole, 5mm devices
- Broad voltage range from 75V-600V
- Various form factors: surface mount, axial leads, no leads
- Low capacitance and insertion loss
- UL 497B recognized
- RoHS compliant
- Devices tested per ITU K.12 recommendations
- Non-radioactive materials

Applications:

- Telecommunications
 - MDF modules, xDSL equipment, RF system protection, antenna, base station
- Industrial and consumer electronics, such as
 - Surge protectors
 - Alarm system

GTCX25-XXXM-R02 Series

Device Voltage Ratings and Part Marking

Part Number	DC Sparkover	Impulse Sparkover		DC Holdover Voltage	On-State Voltage
	@100V/s ±20% Tolerance (V)	@100 V/μs (V)	@1000 V/μs (V)	Per ITU K.12 (<150ms) (V)	Nominal (@ 1A) (V)
GTCX25-750M-R02	75	450	550	<52	20
GTCX25-900M-R02	90	450	550	<52	20
GTCX25-141M-R02	140	500	600	<80	20
GTCX25-151M-R02	150	500	600	<80	20
GTCX25-201M-R02	200	600	700	<135	20
GTCX25-231M-R02	230	600	700	<135	20
GTCX25-251M-R02	250	600	700	<135	20
GTCX25-261M-R02	260	700	800	<135	20
GTCX25-301M-R02	300	800	900	<150	20
GTCX25-351M-R02	350	900	1000	<150	20
GTCX25-401M-R02	400	900	1000	<150	20
GTCX25-421M-R02	420	900	1000	<150	20
GTCX25-471M-R02	470	1050	1150	<150	20
GTCX25-501M-R02	500	1100	1200	<150	20
GTCX25-551M-R02	550	1300	1400	<150	20
GTCX25-601M-R02	600	1300	1400	<150	20

Device Surge Rating, Capacitance, Insulation Resistance, UL

Part Number	Impulse Discharge Current	Impulse Life	AC Discharge Current (1sec duration; 10 hits)	Capacitance	Insulation Resistance	UL Rating
	8x20μs 10 hits	10x1000μs 300 hits	@50 Hz	@1Mhz	@100V*	UL497B #E179610
GTCX25-xxxM-R02	2.5kA	100A	2.5Arms	<1pF	10,000 (MΩ)	All Devices

Devices <=90V measured @ 50V
Devices >=500V measured @ 250V

GTCX25-XXXM-R02 Series

Product Dimensions

DIMENSIONS = MILLIMETERS [INCHES]

Surface-mount (GTCS25-XXXM-R02)

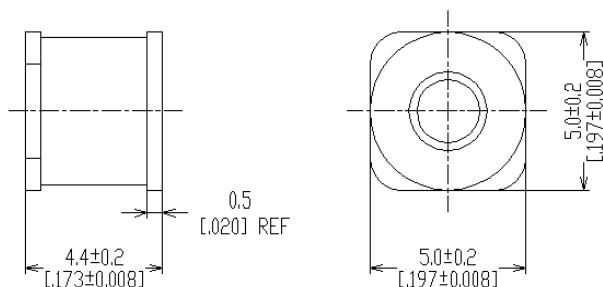

No Leads (GTCN25-XXXM-R02)

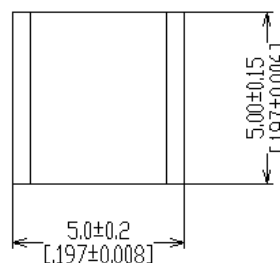

Axial Leads (GTCA25-XXXM-R02)

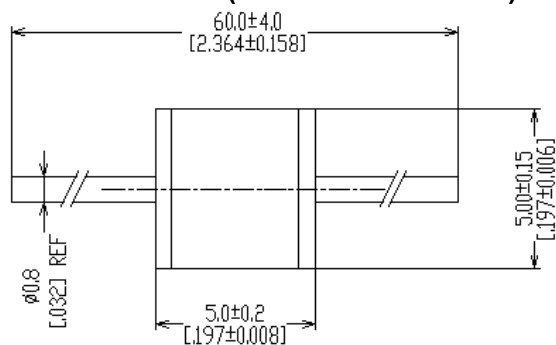

Pad Layout – Surface-mount Devices (GTCS25-XXXM-R02)

	X	Y	Z
	NOM	NOM	NOM
mm:	6.0	3.9	1.3
in*:	(0.197)	(0.154)	(0.051)

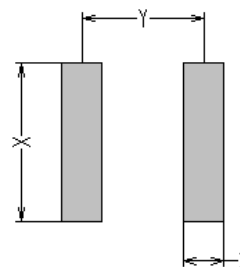

GTCX25-XXXM-R02 Series

General Characteristics

No Radioactive Material

Storage Temperature: -40°C to +90°C

Operating Temperature: -40°C to +90°C

Body: Nickel Plated

Leads: Surface-mount, Axial Devices: Tin Plated

Devices with No Leads: Nickel Plated

Soldering Note: Devices with no leads are non-solderable; meant for insertion into magazine clips

Packaging Information

Part Description	Tray / Reel	Standard Package
No Leads: GTCN25-XXXM-R02	200pcs	5,000pcs
Axial Leads: GTCA25-XXXM-R02	100pcs	1,000pcs
Surface-mount: GTCX25-XXXM-R02	1,500pcs (Reel)	12,000pcs

Part Numbering System

Example Part Number: GTCX25-351M-R02

GT = Gas Tube

C = Ceramic

X = Lead Configuration: **N**= No leads; **A**= Axial Leads; **S**= Surface-mount

2 = 2 Electrode device

5 = 5mm Diameter

351 = DC Spark Over Voltage of 350V (at 100V/s)

M = Tolerance of 20% on DC Spark Over Voltage

R = Product Family Designator

02 = Surge rating: 8x20µs 2.5kA 10 times

GTCX25-XXXM-R02 Series

Part Marking Reference

Example Part Marking: X 35 R02 GN

X	=	Manufacture Mark
35	=	Voltage Designator (35 = 350V)
R02	=	Product Family Designator + Surge Current 2.5kA (8x20µs 10 hits)
GN	=	Year and Week of Manufacture

TE Connectivity, TE Connectivity (Logo) and TE (Logo) are trademarks.

Information furnished is believed to be accurate and reliable. However, users should independently evaluate the suitability of and test each product selected for their own applications. Tyco Electronics Corporation and/or its Affiliates in the TE Connectivity Ltd. family of companies ("TE") reserves the right to change or update, without notice, any information contained in this publication; to change, without notice, the design, construction, processing, or specification of any product; and to discontinue or limit production or distribution of any product. This publication supersedes and replaces all information previously supplied. Without expressed or written consent by an officer of TE, TE does not authorize the use of any of its products as components in nuclear facility applications, aerospace, or in critical life support devices or systems. TE expressly disclaims all implied warranties regarding the information contained herein, including, but not limited to, any implied warranties of merchantability or fitness for a particular purpose. TE's only obligations are those in the TE Standard Terms and Conditions of Sale and in no case will TE be liable for any incidental, indirect, or consequential damages arising from the sale, resale, use, or misuse of its products.