

## PTC SERIES SPECIFICATION

### Common Glossary:

**Rate Zero-power Resistance (Rn):** DC resistance value of the thermistor measured under 25°C by adopting sufficiently low power consumption.

**Maximum Operating Voltage (Vmax)** The maximum rated voltage the PTC thermistor can continuously endure at 25°C.

**Maximum Inrush Current (Imax)** The maximum current (effective value) through the PTC thermistor under max. rated voltage. Exceeding this current may result in damage to the PTC components.

**Reference Temperature (Tsw)** The temperature at which the resistance value of the PTC thermistor increases to twice Rmin, also called Curie temperature.

**Non-trip Current (Int)** Rated current or holding current, at maximum operating temperature, this is the maximum current value that doesn't trip the PTC to the high resistance state. Under these conditions, PTC performs as a fixed resistor.

**Trip Current (It)** The minimum current value that will cause the PTC to trip to the protective high resistance state.

**Operating Temperature Range** The ambient temperature range in which PTC can be used when the maximum voltage is applied. Range is -10°C to +60°C.

**Temperature Coefficient of Resistance (a<sub>T</sub>)** The Temperature coefficient is calculated from the linear range at the steepest portion of resistance (T<sub>b</sub>-T<sub>p</sub>) as illustrated in Fig.1.  $a_T = (I_n R_p - I_n R_b) \cdot 100 / (T_p - T_b) (\% / ^\circ C)$

**Dissipation Factor (δ)** The ratio power dissipation change to temperature change of PTC thermistor (in mw/°C).  $\delta = p / (T - T_r)$

Where P=dissipation power

T=thermistor body temperature

T<sub>r</sub>=room temperature

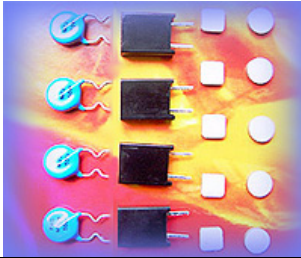

**MZ2 Series for overcurrent protection in telecom**

Advanced developments in telephony equipment in recent years have radically altered the protection requirements for both exchange and subscriber equipment. The PTC thermistor must protect the telephone line circuit against overcurrent, which may be caused the following examples:

- Surges due to lighting strikes on or near to the line plant.
- Short-term induction of alternating voltage from adjacent power lines or railway systems ,usually caused when these lines or systems develop faults.
- Direct contact between telephone lines and power lines.

To provide good protection under such conditions a PTC thermistor is connected in series with each line, usually as secondary protection; see Fig.1. However, even with primary line protection (usually a gas discharge tube ),the PTC thermistor must fulfill severe requirements.

Surge pulses of up to 2 KV can occur and in order to withstand short-term power induction the PTC thermistor must withstand high voltages. If the line has primary protection, a 220V to 300V PTC thermistor is adequate. Without primary protection,600V PTC device is necessary..

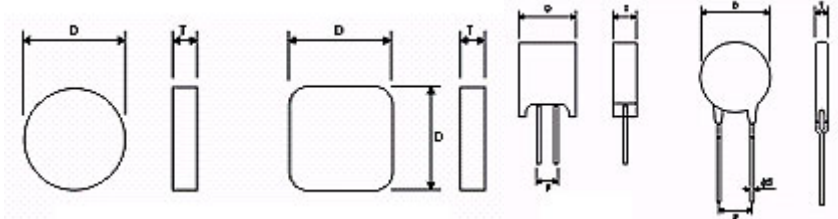

Fig.1

Fig.2

Fig. 3

Fig. 4

**Component outline**

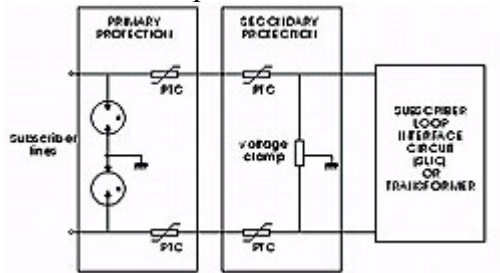
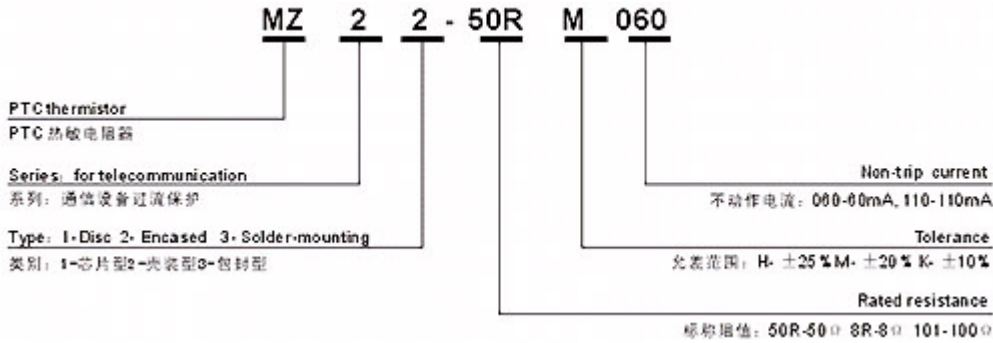

Fig.5 Examples of application

**MARKING OF PARTNUMBER :**



**SPEC. TABLE**

Part No.	Non-trip Current (mA)	Rated Resistance(Ω)	Responding Time(sec)		
			3A → 0.5A	1A → 0.5A	0.5A → 0.15A
MZ21-18RM110A	110	18±20%	0.18	1.1	6.0
MZ21-18RM110B	110	18±20%	0.18	1.1	6.0
MZ22-12RM100	100	12±20%	0.2	1.5	12.0
MZ22-12RM080	80	12±20%	0.2	1.2	10.0
MZ23-12RM080	80	12±20%	0.2	1.5	12.0
MZ23-12RM060	60	50±20%	0.1	0.5	2.0
MZ23-50RM050	50	50±20%	0.1	0.5	2.0
MZ23-55RM060	60	55±20%	0.1	0.65	4.0

Part No.	Vmax.(Vrms)	Fail Model	Dimensions(mm)				
			Dmax	Tmax	Φd	F	Fig
MZ21-18RM110A	250	I	5.5~7.2	1.6~2.2			1
MZ21-18RM110B	250	I	5.5X5.5	1.8~2.2			2
MZ22-12RM100	250	I	9.6	5.2		5.2	3
MZ22-12RM080	250	I	9.6	5.2		5.2	3
MZ23-12RM080	250	I	8.5	5.0	0.6	5.0	4
MZ23-12RM060	300	I	8.5	5.0	0.6	5.0	4
MZ23-50RM050	600	II	8.5	5.0	0.6	5.0	4
MZ23-55RM060	650	III	9.0	5.0	0.6	5.0	4

I .Voltage of power supply:250Vrms,Initial current:10Arms,Time:30minute.

II .Voltage of power supply:600Vrms,Initial current:15Arms,Time:30minute.

III .Voltage of power supply:650Vrms,Initial current:10Arms,Time:30minute.



### **MZ31 Series for time delay start for lighting**

MZ31 series of PTC Thermistor are applicable to various types of fluorescent lamp, electronic ballast and electronic energy-saving lamp. The PTC can be connected across the lamp resonator without changing the circuits. It can change hard start of the ballast and electronic energy-saving lamp to preheated start and the preheating time of the filament can come up to 0.4-2 seconds, which will extend the service life of the fluorescent tube by over 3 times.

The application of the PTC thermistor to achieve preheated start is as follows: Immediately after power is switched on,  $R_t$  is in normal temperature state and its resistance is far lower than the  $C_2$  resistance. The current through  $C_1$  and  $R_t$  forms a return circuit to preheat the filament. After about 0.4-2 seconds,  $R_t$  joule heat temperature exceeds Curie point  $T_{sw}$  and skips into high resistance state of far higher than  $C_2$  resistance. The current passes through  $C_1$  and  $C_2$  to form a return circuit, which causes L resonance and produces high voltage to light the fluorescent tube

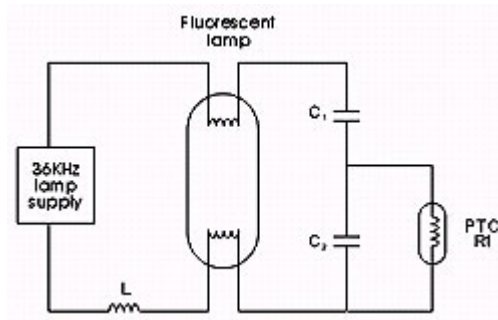

Fig.1 Examples of applications

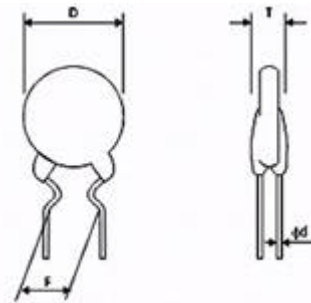
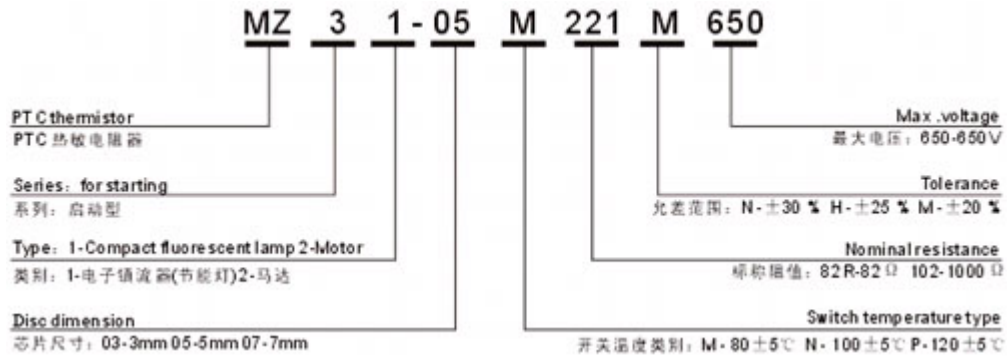

Fig.2 Component outline

**MARKING OF PARTNUMBER :**



**SPEC.TABLE**

Part Number	Switch Temp.(°C)	Resistance at+25°C(Ω)	Max. Voltage(V <sub>AC</sub> )
MZ31-03M101N500	80±5	100±30%	500
MZ31-03M151N500		150±30%	500
MZ31-03M271N650		270±30%	650
MZ31-03M391N650		390±30%	650
MZ31-03M681N800		680±30%	800
MZ31-03M102N800		1000±30%	800
MZ31-03M152N900		1500±30%	900
MZ31-03M332N900		3300±30%	900
MZ31-05M82RN650		80±5	82±30%
MZ31-05M101N650	100±30%		650
MZ31-05M151N650	150±30%		650
MZ31-05M271N800	270±30%		800
MZ31-05M391N800	390±30%		800
MZ31-05M561N900	560±30%		800
MZ31-05M102N900	1000±30%		900
MZ31-05M222N900	2200±30%		900
MZ31-07M68RN650	80±5	68±30%	500
MZ31-07M82RN650		82±30%	650
MZ31-07M101N650		100±30%	650
MZ31-07M151N650		150±30%	650
MZ31-07M221N800		220±30%	800
MZ31-07M271N800		270±30%	800
MZ31-07M391N800		390±30%	800
MZ31-07M681N900		680±30%	900

**SPEC.TABLE**

Part Number	Switch Temp.(°C)	Resistance at+25°C(Ω)	Max. Voltage(V <sub>AC</sub> )
MZ31-03P101N420	120±5	100±30%	420
MZ31-03P151N420		150±30%	420
MZ31-03P271N500		270±30%	500
MZ31-03P391N500		390±30%	500
MZ31-03P561N650		560±30%	650
MZ31-03P821N650		820±30%	650
MZ31-03P102N650		1000±30%	650
MZ31-03P152N650		1500±30%	650
MZ31-05P70RN500		120±5	70±30%
MZ31-05P101N500	100±30%		500
MZ31-05P221N650	220±30%		650
MZ31-05P391N650	390±30%		650
MZ31-05P561N800	560±30%		800
MZ31-05P681N800	680±30%		800
MZ31-05P821N800	820±30%		800
MZ31-05P102N800	1000±30%		800
MZ31-07N68RN500	100±5		68±30%
MZ31-07N82RN650		82±30%	650
MZ31-07N101N650		100±30%	650
MZ31-07N151N650		150±30%	650
MZ31-07N221N800		220±30%	800
MZ31-07N271N800		270±30%	800
MZ31-07N391N800		390±30%	800
MZ31-07N681N900		680±30%	900

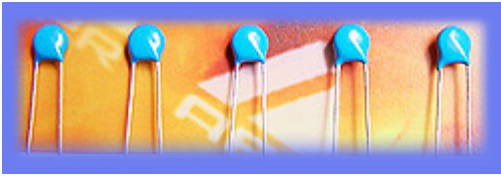

**MZ6 Series for thermal protection**

MZ6 series as a temperature indicator is small in size and little in calorific capacity. It is so useful for indicating any overheating of power transistors and thyristors in the power sources.

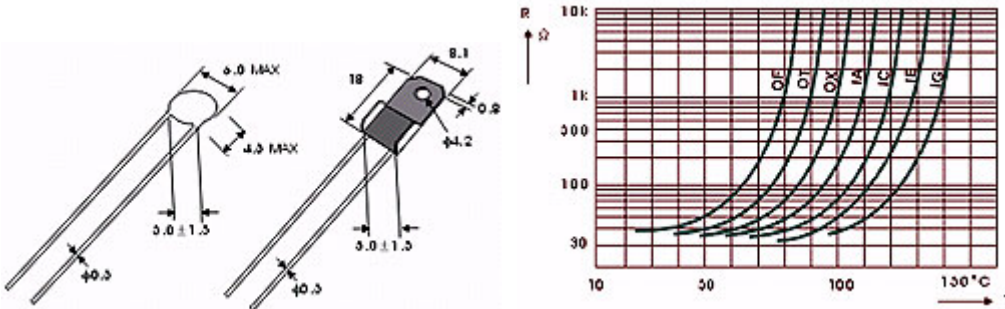

Fig.1 Component outline

Fig.2 Resistance vs. Temperature Characteristics

**SPEC.TABLE**

Part Number	Temperature indication				Vmax(V)	Imax(mA)
	25°C	Tr(°C)	Tr-5°C	Tr+5°C		
MZ6-501RT70	≤100Ω	70	≤500Ω	≥500Ω	16	100
MZ6-501RT80		80				
MZ6-501RT90		90				
MZ6-501RT100		100				
MZ6-501RT110		110				
MZ6-501RT120		120				
MZ6-501RT130		130				



**ZMZ7 Serial PTC Degaussing Thermistor**

**Outline :**

PTC has been widely used in color TV sets and color monitors for its degaussing function. The degaussing thermistor produced by our company features low residual current and quick response, which can quickly overcome the instant current inrush to create a clear and more vivid picture.

**\* Examples of Application :**

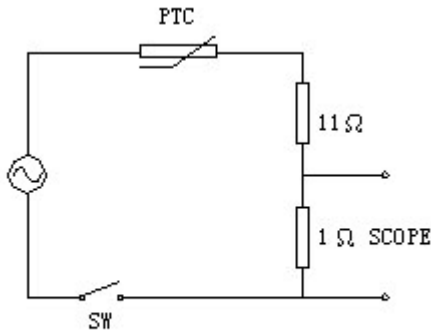

ZMZ72 型 PTC

ZMZ72 Monolithic PTC

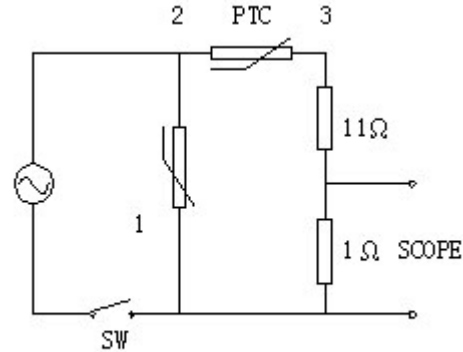

ZMZ73 型 PTC

ZMZ73 Biplate PTC

**\*Part Number :**

ZMZ7 1 18R M 270

① ② ③ ④ ⑤

- ① Product Series : electronic demagnetizing PTC Thermistor
- ② Casing : 1-Welded casing; 2-bakelite casing (two-leg monolithic PTC) 3-Bakelite casing (three-leg biplate PTC) 4-Optical disk
- ③ Zero-power Resistance : 18R-18Ω
- ④ Tolerance in resistance : M-±30% ; M-±20% ; X-+30%/-20%
- ⑤ Maximum Operating Voltage : 270-270V



**Specification :**

Part NO.	Rated Zero Power Resistance( $\Omega$ )	Max.Operating Voltage(V)	Current Attenuation Characteristics			Condition	
			Inrush (Ap-p)	3 sec (mAp-p)	60sen (mAp-p)	Rated Volt(v)	Load resis( $\Omega$ )
MZ71-5R0M140	5 $\pm$ 20%	140	$\geq$ 35	$\leq$ 350	$\leq$ 60	120	1
MZ71-9R0M140	9 $\pm$ 20%	140	$\geq$ 25	$\leq$ 300	$\leq$ 50	120	7.3
MZ71-12RM270	12 $\pm$ 20%	270	$\geq$ 20	$\leq$ 240	$\leq$ 40	220	15
MZ71-14RM270	14 $\pm$ 20%	270	$\geq$ 15	$\leq$ 200	$\leq$ 35	220	10
MZ71-18RM270	18 $\pm$ 20%	270	$\geq$ 20	$\leq$ 250	$\leq$ 30	220	15
MZ71-22RM270	22 $\pm$ 20%	270	$\geq$ 10	$\leq$ 150	$\leq$ 30	220	10
MZ71-27RM270	27 $\pm$ 20%	270	$\geq$ 10	$\leq$ 110	$\leq$ 30	220	5
MZ72-7R0M140	7 $\pm$ 20%	140	$\geq$ 25	$\leq$ 300	$\leq$ 35	120	20
MZ72-12RM270	12 $\pm$ 20%	270	$\geq$ 20	$\leq$ 240	$\leq$ 30	220	15
MZ72-18RM270	18 $\pm$ 20%	270	$\geq$ 20	$\leq$ 250	$\leq$ 25	220	10
MZ73-9R0M140	9 $\pm$ 20%	140	$\geq$ 25	$\leq$ 300	$\leq$ 18	120	3.5
MZ73-12RM270	12 $\pm$ 20%	270	$\geq$ 25	$\leq$ 200	$\leq$ 15	220	20
MZ73-14RM270	14 $\pm$ 20%	270	$\geq$ 25	$\leq$ 200	$\leq$ 12	220	10
MZ73-18RM270	18 $\pm$ 20%	270	$\geq$ 20	$\leq$ 250	$\leq$ 10	220	10
MZ73-27RM270	27 $\pm$ 20%	270	$\geq$ 15	$\leq$ 250	$\leq$ 10	220	10