

### VHF Narrow Band FM Low Cost multi channel radio modules

**The LMT1 transmitter and LMR1 receiver modules offer a 12.5kHz / 25kHz channel spacing multi channel, low power, and reliable VHF data link. This makes the LMT1/LMR1 pair ideally suited to those low power applications where existing wideband modules have insufficient range, or where low cost multi-channel operation is needed without compromising on RF specification or regulatory requirement.**



Figure 1: LMT1 transmitter and LMR1 receiver

#### Features

- Conforms to EN 300 220-2 and EN 301 489-3
- High performance double superhet. PLL synthesizer with TCXO
- quasi-dc (peak sampling) data recovery circuit (for enhanced performance on unbalanced datastreams)
- Data rates up to 5 kbps for standard module
- Usable range over 1km
- Fully screened. Low profile
- Feature-rich interface (RSSI, analogue and digital baseband)
- Re-programmable via UART interface
- Low power requirements

#### Applications

- Handheld terminals
- Industrial telemetry and telecommand
- In-building environmental monitoring and control
- High-end security and fire alarms
- Heavy vehicle/machinery controls

#### Technical Summary

- Operating frequency: 144-146MHz Amateur Radio  
 150.825-152.450MHz Australian LIPD Band  
 151.820-154.600MHz US Multi-Use Radio Service (MURS) band  
 156.525MHz Global Maritime Distress and Safety System  
 173.200 - 173.325MHz UK Telemetry, Telecommand, Fixed Alarm band  
 173.20375-173.39625MHz US FCC Part 90.238 Telemetry
- Other custom variants from 130 - 180MHz on any 2MHz band
- 4 UK allocation channels (32 maximum)
- Transmit power: +10dBm (10mW) nominal @ 3.1V (Adjustable 1 - 25mW)  
 +20dBm (100mW) nominal @ 4.1V (Adjustable 25 - 100mW)
- Supply range: 3.1 – 15V (@10mW) transmitter and receiver
- Current consumption: 34mA @ 10mW, 90mA @ 100mW (transmit) and 20mA (receive)
- Data bit rate: 5kbps max. (Standard module)
- Receiver sensitivity: -118dBm (for 12 dB SINAD)

**Evaluation platforms:** NBEK + LM Series carrier

# LMT1 VHF multi-channel transmitter

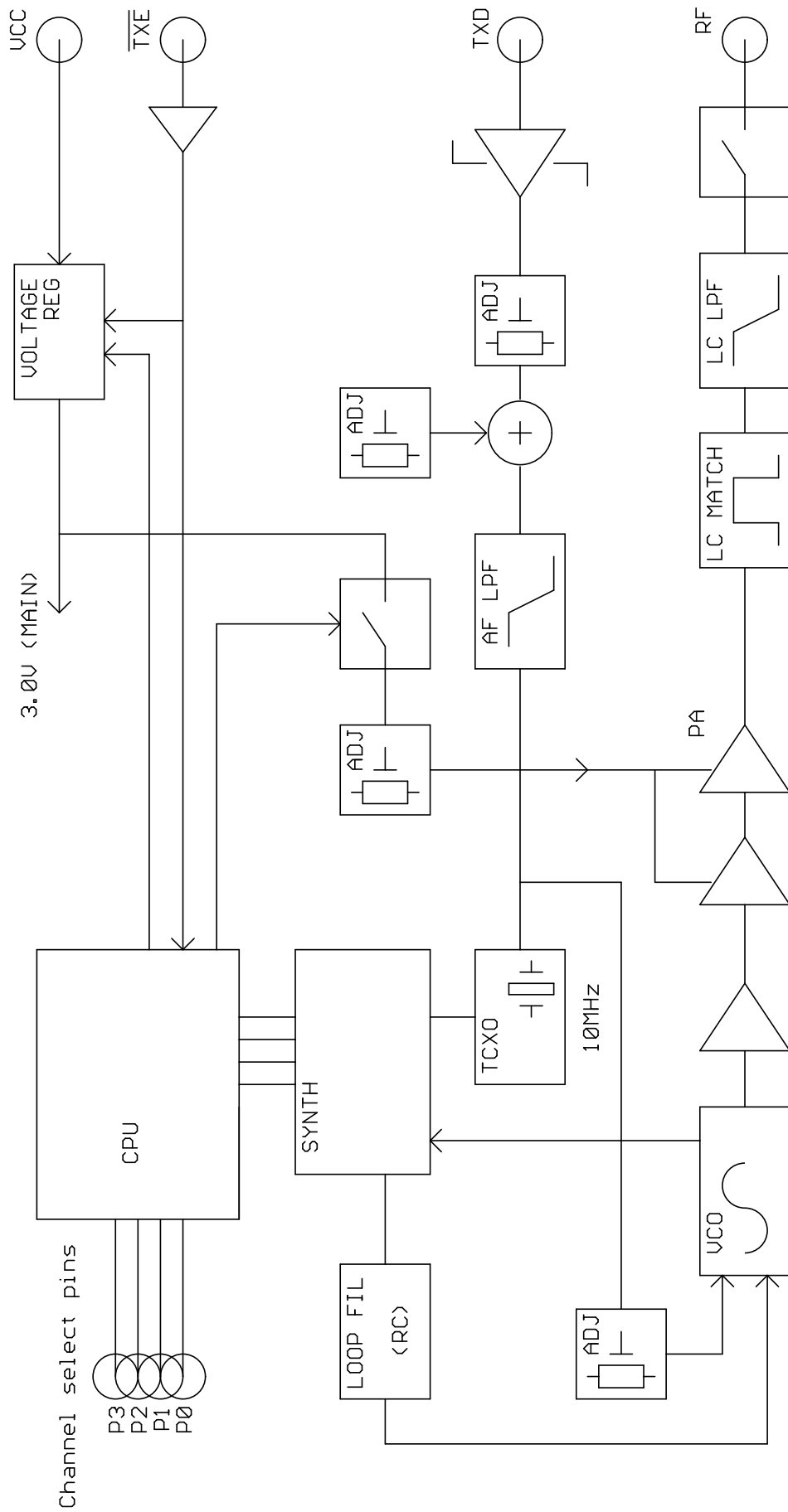

Figure 2: LMT1 block diagram

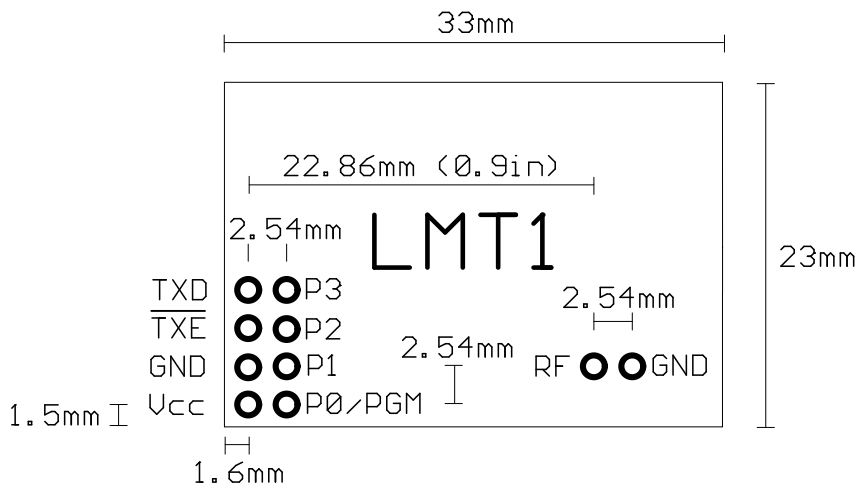

Figure 3: LMT1 footprint (top view)

### Pin description – LMT1

Pin	Name	Function
1a	Vcc	3.1 – 15V power supply (10mW) 4.1V – 15V power supply (100mW)
2a	0V	Ground
3a	TXE	Transmit Enable (active low)
4a	TXD	DC coupled input for 3V CMOS logic. $R_{in}=47k\Omega$ See note 10 below for phase modulation (-PM) version
5a	No pin	Not present in LMT1
1b	P0/PGM	Parallel Channel select LSB Serial frequency programming / configuration <sup>1</sup>
2b	P1	Parallel Channel select
3b	P2	Parallel Channel select
4b	P3	Parallel Channel select MSB
5b	No pin	Not present in LMT1

#### Notes:

- Serial programming is by an inverted, CMOS logic level, 2400 baud UART data stream applied to the P0 pin.
- Channel select inputs have pull-ups (50k $\Omega$ ) to 3v internal rail. Do not exceed 3V logic levels on this port.
- Channel select inputs are active low
- TXE has a 100k $\Omega$  pull-up to Vcc
- All pins are on an 0.1" grid
- The pins 5a/b are not present, but are included in footprint for compatibility with other units in this family
- In the 'off' state a PIN switch open circuits the RF output pin. There are no 'off' state spuri.
- Unit will operate (with marginally reduced specifications and lower (6-8mW) output power) from a 3.0V rail. This must be well regulated and without noise or ripple, as in this state the unit's internal regulator no longer operates, and provides no supply rejection.
- 100mW versions should not be run continuously from supply voltages > 9v
- Phase Modulation (-PM) version LMT1:** 2.6V peak-to-peak level 2100Hz sinewave tone via an external 680pF series capacitor will produce FM deviation of 4.2kHz.

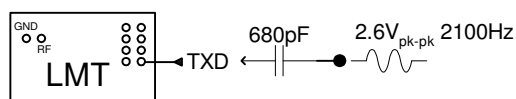

The external 680pF series capacitor on LMT1 TXD input provides a defined 6dB per octave pre emphasis response, to mimic the behavior of a Phase Modulated transmitter.

# LMR1 VHF multichannel receiver

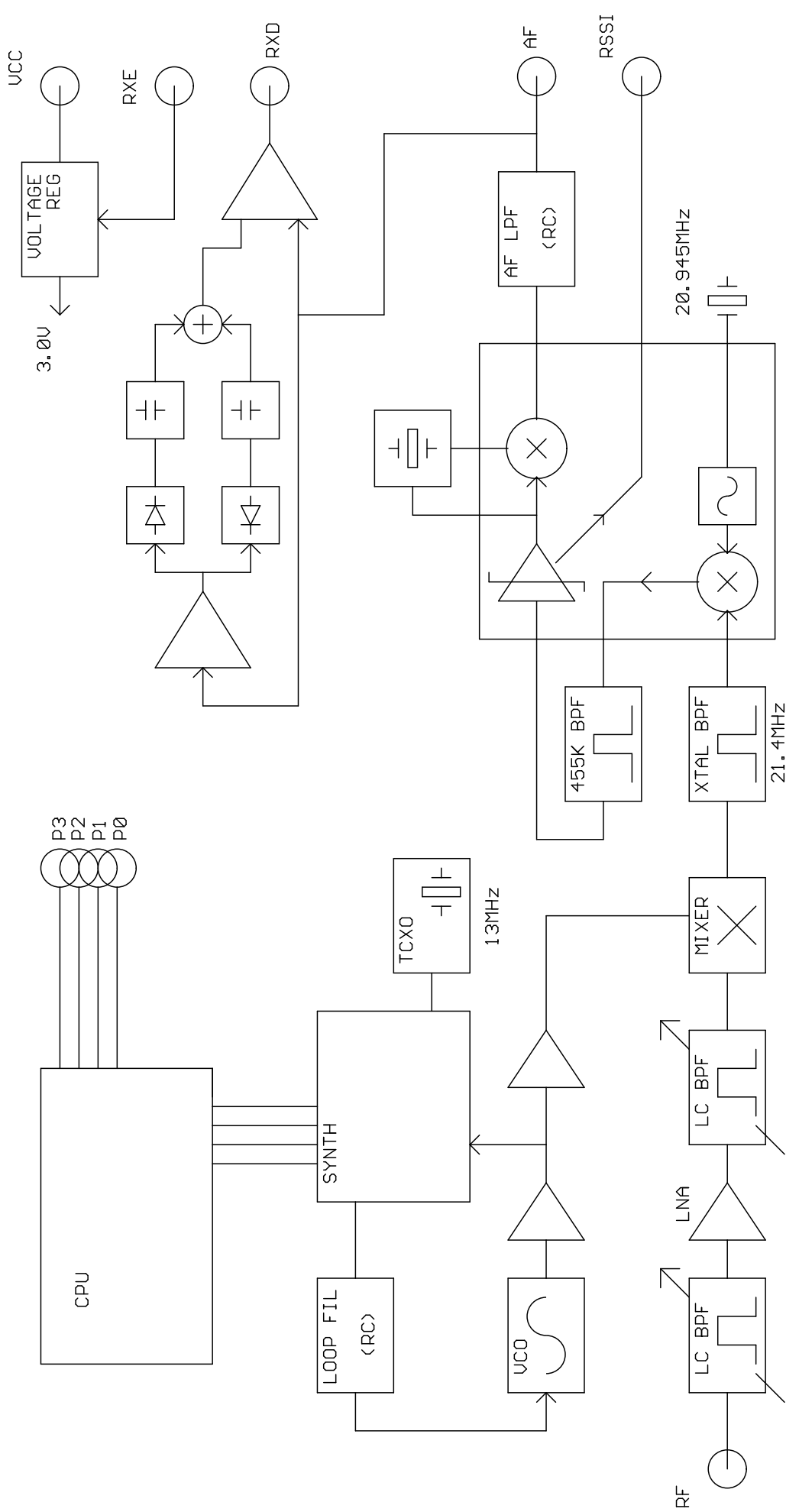

Figure 4: LMR1 block diagram

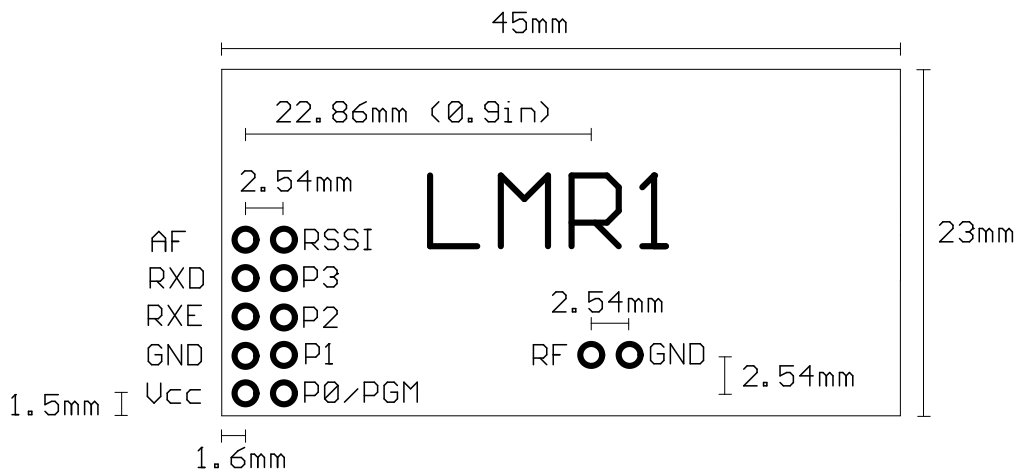

Figure 5: LMR1 footprint (top view)

### Pin description – LMR1

Pin	Name	Function
1a	Vcc	3.1 – 15V power supply
2a	0V	Ground
3a	RXE	Receiver Enable (active high)
4a	RXD	Data out (open collector, no pull-up)
5a	AF out	700mV p-p audio. DC coupled, approx 0.8v bias.
1b	P0/PGM	Parallel Channel select LSB Serial frequency programming / configuration <sup>1</sup>
2b	P1	Parallel Channel select
3b	P2	Parallel Channel select
4b	P3	Parallel Channel select MSB
5b	RSSI	DC level between 0.5v and 2.2v. 60dB dynamic range

#### NOTES:

1. Serial programming is by an inverted, cmos logic level, 2400 baud UART data stream applied to the P0 pin.
2. Channel select inputs have pull-ups (50kΩ) to 3v internal rail. Do not exceed 3v logic levels on this port.
3. Channel select inputs are active low
4. All pins are on an 0.1" grid
5. Data recovery circuit used for RXD is not a simple 'average and compare' type. It is a peak sampling quasi-DC coupled design, allowing a greater than usual flexibility in data format.
6. Unit will operate (with marginally reduced specifications) from a 3.0v rail. This must be well regulated and without noise or ripple, as in this state the unit's internal regulator no longer operates, and provides no supply rejection.

## Serial interface commands

2400 baud UART. 8 bit data, no parity, 1 start bit, 1 or 2 stop bits.

Serial data is sent to the unit on one of the parallel channel select pins (P0). It is very important that the unit does not 'decode' switch bounce in ordinary operation as a command string, or spurious re-writing of the e2prom will result. For this reason the user must send the 16 character string ENABLESERIALMODE (followed by a carriage return) to activate the serial command mode before sending any of the command strings listed below. Command mode is disabled on power down, or on reception of a # character. To successfully program the unit, it must be enabled ('RXE high (rx) or TXE low (tx)).

GOCHAN aa	Serially select channel aa, where aa is ch0 to ch31
LOAD aa nnnnn	Set value of N register for channel aa, where aa is Channels 0 to 31
SETPAR	Channel selected by 4 bit parallel inputs (ch0 to ch15 only)
SETSER	Channel selected by most recent GOCHAN operation
RVALUE rrrr	Set value for R register
SINGLE nnnnn	Set value of N for single channel operation. N value NOT stored in EEPROM
<cr>	Process entry
/	Clear all buffers
#	Disable command mode

aa = a two digit channel number from 00 to 31

nnnnn = synthesizer N register value (up to 65535)

rrrr = synthesizer R register value (up to 16383)

### For LMT1 Transmitter:

$$R = \frac{f_{Xtal}}{f_{channelspacing}} = \frac{10MHz}{25kHz}, \text{ So } R=400$$

$$N_{TX} = \frac{f_{RF}}{f_{Channelspacing}} = \frac{173.250MHz}{25kHz} = 6930$$

### For LMR1 Receiver:

$$R = \frac{f_{Xtal}}{f_{channelspacing}} = \frac{13MHz}{25kHz}, \text{ So } R=520$$

$$N_{RX} = \frac{f_{RF} - 21.4MHz}{f_{Channelspacing}} = \frac{173.250MHz - 21.4}{25kHz} = 6074$$

**Notes:** 1. A pause of at least 50ms must be allowed between command strings (EEPROM programming time).

2. SINGLE mode does not store the N value in EEPROM. Therefore the unit is inoperative after a power down until either another valid SINGLE command is received, or mode is changed by a GOCHAN, SETPAR or SETSER command. SINGLE mode is intended for frequency agile applications.

3. For UK version (173.200 - 173.325MHz band) the following channel assignment is supplied:

CH0: 173.250MHz

CH1: 173.275MHz

CH2: 173.300MHz

CH3: 173.325MHz

CH4 - CH7: 173.225MHz (only used for alarm applications)

CH8 - CH31: 173.325MHz

## Condensed specifications

<b>Frequency</b>	144-146MHz Amateur Radio 150.825-152.450MHz (Australian LIPD Band) 151.820-154.600MHz US Multi-Use Radio Service (MURS) band 156.525MHz Global Maritime Distress and Safety System 173.200-173.325MHz (UK Telemetry, Telecommand, Alarm) 173.20375-173.39625MHz US FCC Part 90.238 Telemetry Other custom variants from 130 - 180MHz on any 2MHz band
<i>Frequency stability</i>	±1.5kHz
<i>Channel spacing</i>	25kHz (12.5kHz by special order)
<i>Number of channels</i>	16 channels controlled by parallel port or 32 via serial UART interface
Operating temperature	-20 °C to +70 °C (Storage -30 °C to +70 °C)
Spurious radiations	Compliant with ETSI EN 300 220-3 and EN 301 489-3
<b>Transmitter</b>	
Output power	+10dBm (10mW) ±1dB nominal (factory adjustable 1 - 25mW) and +20dBm (100mW) ±1dB nominal (factory adjustable 25 - 100mW)
Peak deviation	±3kHz (±1.5kHz @ 12.5kHz channel spacing) -PM version: ±4.2kHz (for 2.6V pk-pk 2100Hz)
TX on switching time	30ms from TXE transition
Modulation type	FSK (F3D) Phase modulation (-PM version)
TX modulation bandwidth	DC – 5kHz (3V CMOS compatible)
Adjacent channel TX power	<-37dBm
TX spurious	<-40dBm (no RF output in Standby)
<i>Supply</i>	
Voltage	3.1V – 15V (10 – 25mW) 4.1V – 15V (25 – 100mW);
Current	34mA nominal transmit (@10mW) 90mA nominal transmit (@100mW) <8µA standby (TXE high or floating)
Inputs	data (CMOS/TTL compatible)
Size	33 x 23 x 9mm
Interface <i>User</i>	10 (8) pin 0.1" pitch dual row (5+5) header
<i>RF</i>	2pin 0.1" pitch
Recommended PCB hole size	1.2mm
<b>Receiver</b>	
Sensitivity	-118dBm for 12dB SINAD
S/N ratio	35dB (min), 40dB (typ) on AF output
AF bandwidth (-3dB)	4kHz
image	<-60db
Other spurious	<-70dbm
Blocking	Better than 84dB
Adjacent channel	<-60dB
LO re-radiation	-70dBm
<i>Supply</i>	
<i>Voltage</i>	3.1V – 15V
<i>Current</i>	20mA receive <1µA standby (RXE low)
Outputs	RSSI, audio, data (quasi DC data recovery circuit)
Size	46 x 23 x 9 mm
Interface <i>User</i>	10 pin 0.1" pitch dual row (5+5) header
<i>RF</i>	2pin 0.1" pitch
Recommended PCB hole size	1.2mm

## RX Received Signal Strength Indicator (RSSI)

The LMR1 has wide range RSSI that measures the strength of an incoming signal over a range of 60dB or more. This allows assessment of link quality and available margin and is useful when performing range tests.

The output on pin 5b of the module has a standing DC bias of up to 0.5V with no signal, rising to 2.5V at maximum indication (RF input levels of -40dBm and above).  $\Delta V_{min-max}$  is typically 2V and is largely independent of standing bias variations. Output impedance is 40k $\Omega$ . Pin 5b can drive a 100 $\mu$ A meter directly, for simple monitoring.

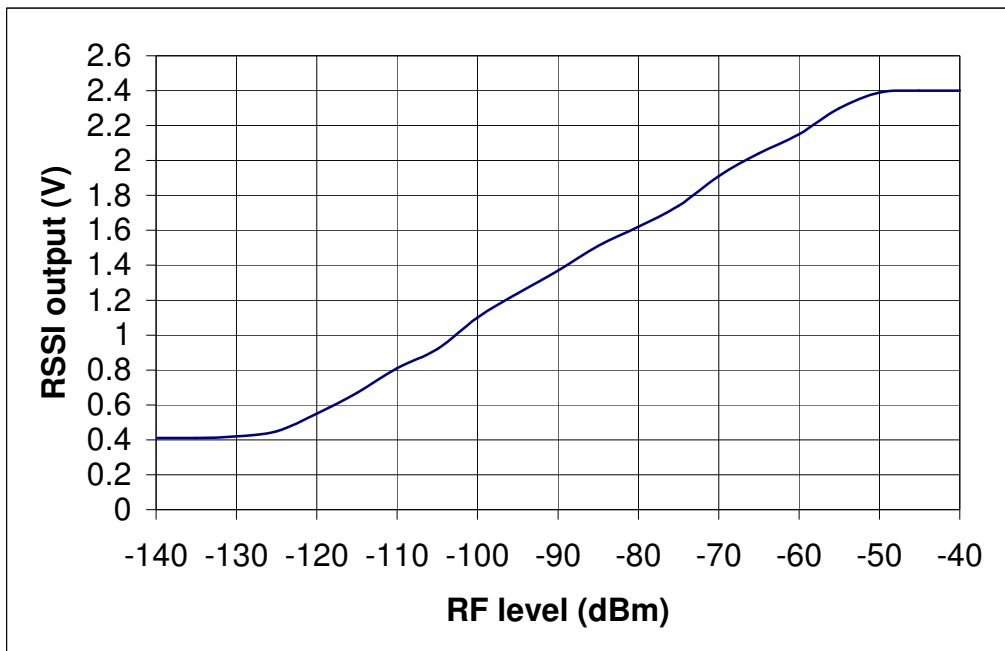

Figure 6: typical RSSI level with respect to received RF level at LMR1 antenna pin

## Antenna requirements

Three types of integral antenna are recommended and approved for use with the module:

- A) **Whip** This is a wire, rod ,PCB track or combination connected directly to RF pin of the module. Optimum total length is 410mm (1/4 wave @ 173MHz). Keep the open circuit (hot) end well away from metal components to prevent serious de-tuning. Whips are ground plane sensitive and will benefit from internal 1/4 wave earthed radial(s) if the product is small and plastic cased
- B) **Helical** Wire coil, connected directly to RF pin, open circuit at other end. This antenna is very efficient given it's small size (20mm x 4mm dia.). The helical is a high Q antenna, trim the wire length or expand the coil for optimum results. The helical de-tunes badly with proximity to other conductive objects.
- C) **Loop** A loop of PCB track tuned by a fixed or variable capacitor to ground at the 'hot' end and fed from RF pin at a point 20% from the ground end. Loops have high immunity to proximity de-tuning.

FEATURE	A	B	C
	<i>whip</i>	<i>helical</i>	<i>loop</i>
Ultimate performance	***	**	*
Easy of design set-up	***	**	*
Size	*	***	**
Immunity proximity effects	*	**	***



The antenna choice and position directly controls the system range. Keep it clear of other metal in the system, particularly the 'hot' end. The best position by far, is sticking out the top of the product. This is often not desirable for practical/ergonomic reasons thus a compromise may need to be reached. If an internal antenna must be used, try to keep it away from other metal components, particularly large ones like transformers, batteries and PCB tracks/earth plane. The space around the antenna is as important as the antenna itself.

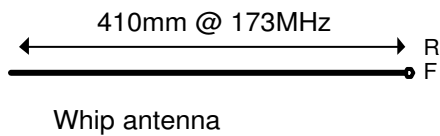

wire, rod, PCB track  
or a combination of these  
length(mm) = 71250 / freq(MHz)



35-40 turns wire spring  
length 120mm, dia 10mm  
trim wire length or expand coil for  
best results

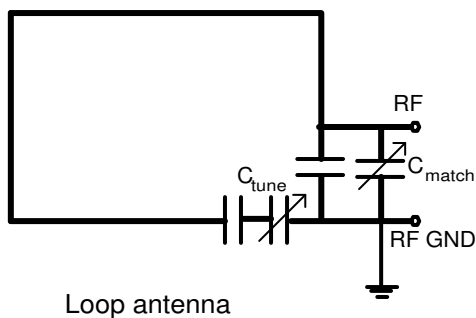

track width = 1mm  
min. area 500mm<sup>2</sup>  
capacitors may be variable or fixed  
(values depend on loop dimensions)

Figure 7: Antenna types

## Ordering Information:

Part No.	Description	Channel Frequencies (MHz)	RF power (mW)	Channel Spacing (kHz)	Data rate kbps
LMT1-144-5	Transmitter	CH0:144.000 – CH31:144.775	100	25	5
LMR1-144-5	Receiver				
LMT1-151-5	Transmitter	CH0:150.825 – CH31:151.600	100	25	5
LMR1-151-5	Receiver				
LMT1-151-5-12k5-MURS	Transmitter	CH0:150.820, CH1:150.880, CH2:151.940, CH3:154.570, CH4:154.600	100	12.5	5
LMR1-151-5-12k5-MURS	Receiver				
LMT1-156.525-PM	Transmitter	156.525MHz	100	25	2.6V pk-pk 2.1kHz
LMT1-173-5	Transmitter	CH0:173.250 – CH3:173.325 CH4 – CH7:173.225 CH8 – CH31:173.325	10	25	5
LMR1-173-5	Receiver				
LMT1-173-5-12k5-FCC	Transmitter	CH0:173.20375, CH1:173.210, CH2:173.2375, CH3:173.2875, CH4:173.3125, CH5:173.3375, CH6:173.3625, CH7:173.39625	100	12.5	5
LMR1-173-5-12k5-FCC	Receiver				
LMT1-xxx-5	Where xxx is any 2MHz band from 130MHz to- 180MHz		10/100	25	5
LMR1-xxx-5					

# **Radiometrix Ltd**

**Hartcran House  
231 Kenton Lane  
Harrow, Middlesex  
HA3 8RP  
ENGLAND  
Tel: +44 (0) 20 8909 9595  
Fax: +44 (0) 20 8909 2233  
sales@radiometrix.com  
www.radiometrix.com**

## **Copyright notice**

This product data sheet is the original work and copyrighted property of Radiometrix Ltd. Reproduction in whole or in part must give clear acknowledgement to the copyright owner.

## **Limitation of liability**

The information furnished by Radiometrix Ltd is believed to be accurate and reliable. Radiometrix Ltd reserves the right to make changes or improvements in the design, specification or manufacture of its subassembly products without notice. Radiometrix Ltd does not assume any liability arising from the application or use of any product or circuit described herein, nor for any infringements of patents or other rights of third parties which may result from the use of its products. This data sheet neither states nor implies warranty of any kind, including fitness for any particular application. These radio devices may be subject to radio interference and may not function as intended if interference is present. We do NOT recommend their use for life critical applications.

The Intrastat commodity code for all our modules is: 8542 6000.

## **R&TTE Directive**

After 7 April 2001 the manufacturer can only place finished product on the market under the provisions of the R&TTE Directive. Equipment within the scope of the R&TTE Directive may demonstrate compliance to the essential requirements specified in Article 3 of the Directive, as appropriate to the particular equipment.

Further details are available on The Office of Communications (Ofcom) web site:

**<http://www.ofcom.org.uk/radiocomms/ifi/>**

### *Information Requests*

*Ofcom*

*Riverside House*

*2a Southwark Bridge Road*

*London SE1 9HA*

*Tel: +44 (0)845 456 3000 or 020 7981 3040*

*Fax: +44 (0)20 7783 4033*

*information.requests@ofcom.org.uk*

### *European Radiocommunications Office (ERO)*

*Peblingehus*

*Nansensgade 19*

*DK 1366 Copenhagen*

*Tel. +45 33896300*

*Fax +45 33896330*

*ero@ero.dk*

*www.ero.dk*

---