



Best Single Chip USB Audio Controller for PC Entertainment

CM102-A/102S USB 2CH Audio Controller Data Sheet

Version 1.4

C-MEDIA ELECTRONICS INC.

TEL: 886-2-8773-1100 FAX: 886-2-8773-2211

6F, 100, Sec. 4, Civil Boulevard, Taipei, Taiwan 106, R.O.C.

For detailed product information, please contact sales@cmmedia.com.tw

NOTICES

THIS DOCUMENT IS PROVIDED “AS IS” WITH NO WARRANTIES WHATSOEVER, INCLUDING ANY WARRANTY OF MERCHANTABILITY, NONINFRINGEMENT, FITNESS FOR ANY PARTICULAR PURPOSE, OR ANY WARRANTY OTHERWISE ARISING OUT OF ANY PROPOSAL, DOCUMENT OR SAMPLE.

ALL RIGHTS RESERVED. NO PART OF THIS DOCUMENT MAY BE REPRODUCED OR TRANSMITTED IN ANY FORM OR BY ANY MEANS, ELECTRONIC OR MECHANICAL, INCLUDING INFORMATION STORAGE AND RETRIEVAL SYSTEMS, WITHOUT PERMISSION IN WRITING FROM THE C-MEDIA ELECTRONICS, INC.

Third-party brands and names are the property of their respective owners.

Copyright 2002-2003 © C-Media Electronics Inc.

C-Media reserves the right to modify the specifications without further notice

1. DESCRIPTION AND OVERVIEW

CM102 series is a highly integrated single chip for USB speaker application. Minimum external components are needed for building an USB speaker system, which makes CM102-A/S a simple and very cost-effective solution. Since no driver is necessary for audio playback on all major OS; CM102-A/S provides a truly plug-and-play feature for external digital audio playback. For energy saving, USB suspend mode and resume is supported by CM102-A/S. With power amplifier enable pin and volume control VR input pin, a traditional speaker front panel design can be built. More flexible and customized design is possible with GPIO pin, which is accessible by USB vendor specific request.

Features

- USB 2.0 Full Speed Compatible
- USB audio device class specification v1.0 Compatible
- USB bus powered 500mA operation with suspend mode support
- Single 12MHz crystal input with on-chip PLL and embedded USB transceiver
- USB audio function topology has 1 input terminal, 1 output terminal, and 1 feature unit
- Alternate zero bandwidth setting for releasing bandwidth on USB bus during inactive operation
- Isochronous transfer using adaptive synchronization with internal PLL
- High performance 48KHz sampling rate for audio playback
- Embedded high performance 16 bit audio DAC
- Embedded class AB power amplifier for speaker driving
- Embedded power on reset block and Power amplifier enable / disable control pin
- Volume control input with simple external VR circuit
- GPIO pin for application specific usage
- **S/PDIF output interface**
- Single 5V external power supply with internal power regulation
- 3.3V IO with 5V tolerance; 3.3V core logics design
- Compatible with Win 98SE / Win ME / Win 2000 / Win XP, and Mac OS 9 / OS X without additional driver
- Compact 18 pin SOP package
- Target application: multimedia USB audio box, decoder integrated, pen driver
- **Dolby Digital Real Time Content Encoder (AC-3) software value added**
- **Software Xear 3D Sound Technology With HRTF 3D, EAX™, Speaker Shifter and Virtual 5.1CH effects**

PIN DESCRIPTIONS

CM102-A/102S

PIN #	Signal Name	PIN #	Signal Name
1	PAEN	10	TEST
2	GPIO	11	VREF
3	XO	12	VOLADJ
4	XI	13	AVDD
5	DVDD1	14	LOL
6	DVDD2	15	LOR
7	USBDP	16	AVSS
8	USBDM	17	SPDIF Out
9	DVSS	18	PDSW

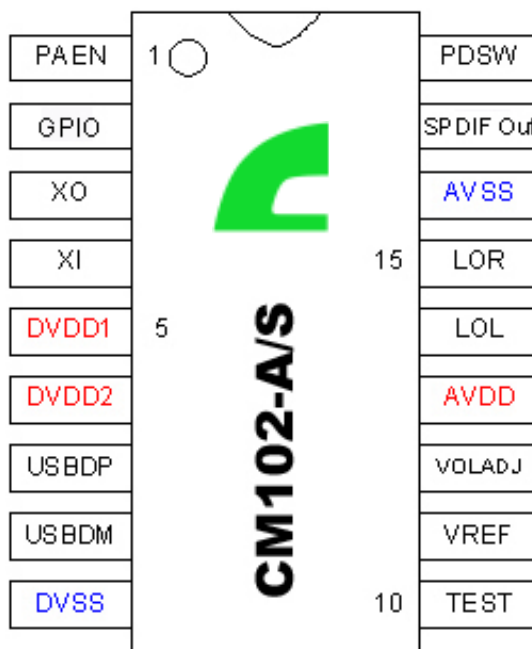
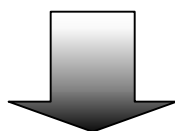

Figure 1. Pin Assignments (Top View)

Pin #	Symbol	Type	Description
1	PAEN	DI, PD	Power amplifier enable; H – normal mode, L – power down power amplifier
2	GPIO	DIO, PD	GPIO pin, default is input mode after reset; accessible by USB vendor specific request
3	XO	AO	Clock output pin for 12MHz oscillator
4	XI	AI	Clock input pin for 12MHz oscillator
5	DVDD1	P	5V digital power
6	DVDD2	P	3.3V voltage from internal regulator for decouple capacitor connection It is not affected by power down mode and can be used to connect USB pull up resistor.
7	USBDP	AIO	USB data D+
8	USBDM	AIO	USB data D-
9	DVSS	P	5V digital ground
10	TEST	DI, PD	Test mode select pin; pull low in normal mode operation
11	VREF	AO	Connect to external decouple capacitor for embedded bandgap
12	VOLADJ	AI	0 ~ 2.25V input for volume adjustment by external VR; pull high to disable VR volume adjustment function
13	AVDD	P	5V analog power
14	LOL	AO	Line out left channel
15	LOR	AO	Line out right channel
16	AVSS	P	5V analog ground
17	SPDIF Out	DO	SPDIF Out
18	PDSW	DO, 4mA	Power down switch control 1: normal mode, 0: power down mode

- Note: DI – digital input pin , DO – digital output pin, DIO – digital bi-directional pin, P – power pin, PD – pull down with 100K Ohm resistor, AI – analog input, AO – analog output

Block Diagram of CM102-A/102S

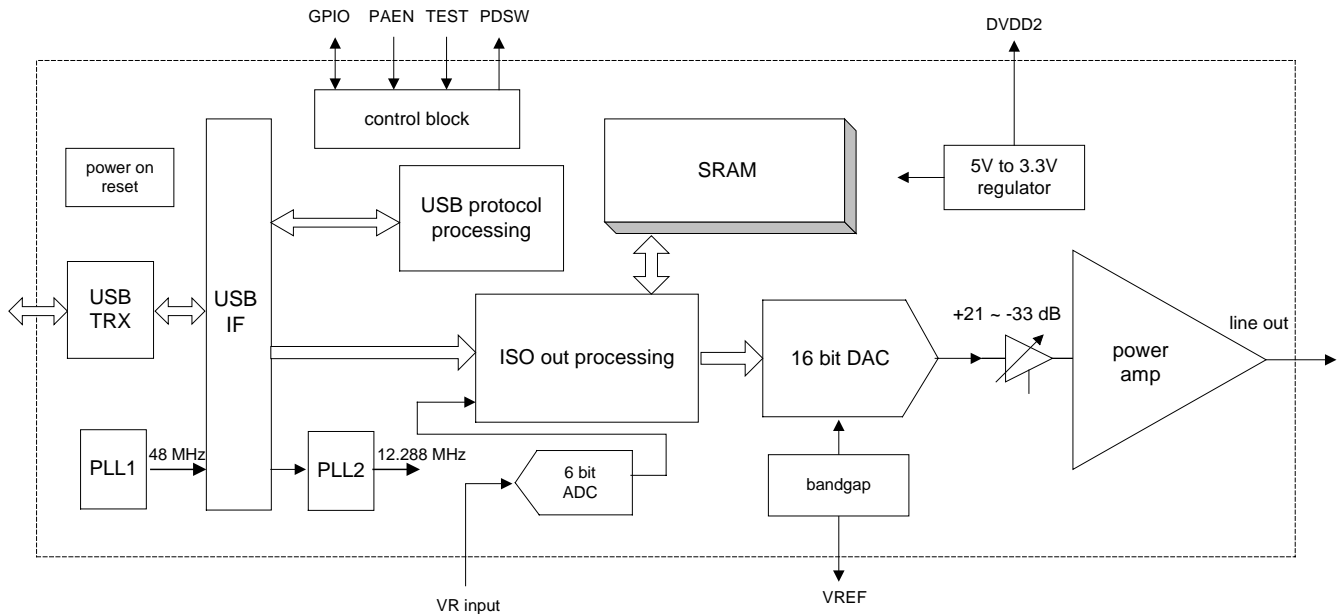

Figure 2 : Block Diagram Of CM102-A/102S

Vendor Specific Request for GPIO Access

GPIO write

Offset	Field	Size	Value	Description
0	bmRequestType	1	43	
1	bRequest	1	01	
2	wValue	2	Value	Bit 0: GPIO value Bit 1: 1: output; 0: input
4	wIndex	2	0000	
6	wLength	2	0000	

GPIO read

Offset	Field	Size	Value	Description
0	bmRequestType	1	C3	
1	bRequest	1	81	
2	wValue	2	Value	Bit 0: GPIO value Bit 1: 1: output; 0: input
4	wIndex	2	0000	
6	wLength	2	0001	

2. ORDERING INFORMATION

Model Number	Package	Operating Ambient Temperature	Supply Range
CM102-A/102S	18-Pin PDIP	0 o C to +70 o C	DVdd = 4.5V, AVdd = 5.5V
	18-Pin SOP	0 o C to +70 o C	DVdd = 4.5V, AVdd = 5.5V

Outline of Dimensions Dimensions shown in inches and (mm)

◆18- Plastic dual-in-line packaging (PDIP)

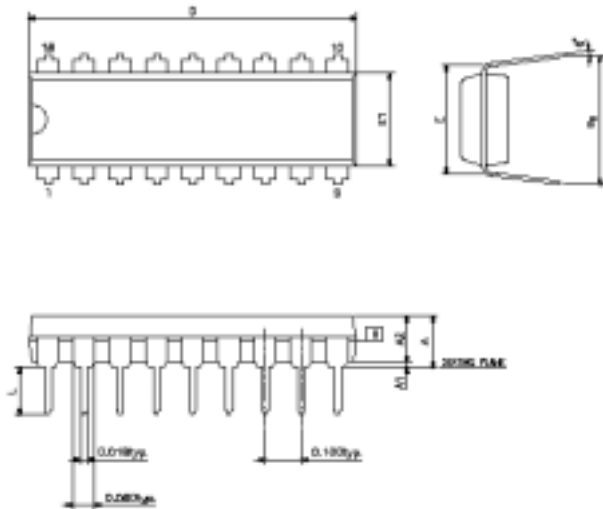

SYMBOLS	MIN.	NOR.	MAX.
A	—	—	0.210
A1	0.015	—	—
A2	0.125	0.130	0.135
D	0.880	0.900	0.920
E	0.300 BSC.		
E1	0.245	0.250	0.255
L	0.115	0.130	0.150
e _B	0.335	0.355	0.375
θ°	0	7	15

Figure 3 : Mechanical Dimension of CM102-A

◆18- Pin SOP

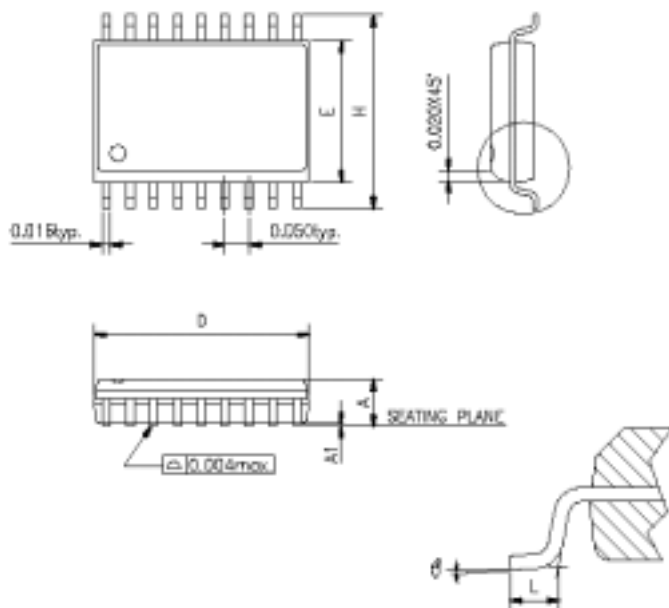

SYMBOLS	MIN.	MAX.
A	0.093	0.104
A1	0.004	0.012
D	0.447	0.463
E	0.291	0.299
H	0.394	0.419
L	0.016	0.050
θ°	0	8

Figure 4 : Mechanical Dimension of CM102S

TABLE OF CONTENTS

1. DESCRIPTION AND OVERVIEW	2
2. ORDERING INFORMATION	6
3. PIN/SIGNAL DESCRIPTIONS	9
3.1 CLOCK PIN	9
3.2 ANALOG I/O	9
3.3 POWER / GROUND	9
3.4 CONFIGURATION / GPIO	10
4. VR MAPPING TABLE	11
5. VENDOR SPECIFIC REQUEST FOR GPIO ACCESS	12
6. USB DESCRIPTORS	13
6.1 DEVICE DESCRIPTORS	13
6.2 CONFIGURATION DESCRIPTOR	13
6.3 USB AUDIO TOPOLOGY DIAGRAM	14
7. ELECTRICAL CHARACTERISTICS	15
7.1 ABSOLUTE MAXIMUM RATING	15
7.2 OPERATION CONDITIONS	15
7.3 ELECTRICAL PARAMETERS	15
7.4 AUDIO PERFORMANCE	16
8. FREQUENCY RESPONSE GRAPHS	17
8.1 AUDIO PERFORMANCE	17
8.2 LINE OUTPUT SERIES CAPACITORS: 1000MF	17
9. APPLICATION CIRCUIT REFERENCE	18

10. LIST OF FIGURES

Figure 1 : Pin Assignments (Top View)	3
Figure 2 : Block Diagram Of CM102-A/102S	5
Figure 3 : Mechanical Dimension of CM102-A	6
Figure 4 : Mechanical Dimension of CM102S	6
Figure 5 : Topology Diagram	14
Figure 6 : Frequency Response of CM102-A/S with 220 μ F Series Capacitor	17
Figure 7 : Frequency Response of CM102-A/S with 1000 μ F Series Capacitor	17
Figure 8 : Application Circuit of CM102 Rev 1.6	18

3. PIN/SIGNAL DESCRIPTIONS

3.1 Clock Pin

These signals connect CM102-A/CM102S to external clock source signal.

Signal Name	Type	Pin No	Description
XO	O	3	Clock output pin for 12MHz oscillator.
XI	I	4	Clock input pin for 12MHz oscillator.

3.2 Analog I/O

These signals connect CM102-A/CM102S to analog signals, external VR, and decouple capacitor.

Signal Name	Type	Pin No	Description
VREF	O	11	Connect to external decouple capacitor for embedded bandgap.
VOLADJ	I	12	0 ~ 2.25V input for volume adjustment by external VR; pull high to disable VR volume adjustment function.
LOL	O	14	Line out left channel.
LOR	O	15	Line out right channel.
USBDP	I/O	7	USB data D+.
USBDM	I/O	8	USB data D-.

3.3 Power / Ground

Analog VDD is 5V, Digital VDD is 3.3V and 5V. Analog ground plane and digital ground plane should be separated well.

Signal Name	Type	Pin No	Description
DVDD1	I	5	5V digital power.
DVDD2	O	6	3.3V voltage from internal regulator for decouple capacitor connection. It is not affected by power down mode and can be used to connect USB pull up resistor.
DVSS	I	9	Digital ground.
AVDD	I	13	5V analog power.
AVSS	I	16	5V analog ground.

3.4 Configuration / GPIO

These signals are for various configuration and GPIO.

Signal Name	Type	Pin No	Description
PAEN	I	1	Power amplifier enable; H – Normal mode, L – Power down power amplifier.
GPIO	I/O	2	GPIO pin, default is input mode after reset; accessible by USB vendor specific request.
TEST	I	10	Test mode select pin; pull low in normal mode operation.
SPDIF Out	O	17	This pin is used for SPDIF Out.
PDSW	O	18	Power down switch control. H - Normal mode, L - Power down mode.

PAEN / GPIO / TEST:

Internal pull down via 100KΩ resistor.

4. VR MAPPING TABLE

VOLADJ (pin 12) can be pulled high to disable external VR volume adjustment function. Voltage level set by external VR can change the CM102-A/CM102S volume control value according to the following table.

Input DC voltage relative to 2.25V	Adjust value added to volume control (unit : DAC step)	Input DC voltage relative to 2.25V	Adjust value added to volume control (unit : DAC step)
$\geq 96.5\%$	-37 (MUTE)	48.5 ~ 50 %	0
95 ~ 96.5 %	-30	47 ~ 48.5 %	+1
93.5 ~ 95 %	-29	45.5 ~ 47 %	+2
92 ~ 93.5 %	-28	44 ~ 45.5 %	+3
90.5 ~ 92 %	-27	42.5 ~ 44 %	+4
89 ~ 90.5 %	-26	41 ~ 42.5 %	+5
87.5 ~ 89 %	-25	39.5 ~ 41 %	+6
86 ~ 87.5 %	-24	38 ~ 39.5 %	+7
84.5 ~ 86 %	-23	36.5 ~ 38 %	+8
83 ~ 84.5 %	-22	35 ~ 36.5 %	+9
81.5 ~ 83 %	-21	33.5 ~ 35 %	+10
80 ~ 81.5 %	-20	32 ~ 33.5 %	+11
78.5 ~ 80 %	-19	30.5 ~ 32 %	+12
77 ~ 78.5 %	-18	29 ~ 30.5 %	+13
75.5 ~ 77 %	-17	27.5 ~ 29 %	+14
74 ~ 75.5 %	-16	26 ~ 27.5 %	+15
72.5 ~ 74 %	-15	24.5 ~ 26 %	+16
71 ~ 72.5 %	-14	23 ~ 24.5 %	+17
69.5 ~ 71 %	-13	21.5 ~ 23 %	+18
68 ~ 69.5 %	-12	20 ~ 21.5 %	+19
66.5 ~ 68 %	-11	18.5 ~ 20 %	+20
65 ~ 66.5 %	-10	17 ~ 18.5 %	+21
63.5 ~ 65 %	-9	15.5 ~ 17 %	+22
62 ~ 63.5 %	-8	14 ~ 15.5 %	+23
60.5 ~ 62 %	-7	12.5 ~ 14 %	+24
59 ~ 60.5 %	-6	11 ~ 12.5 %	+25
57.5 ~ 59 %	-5	9.5 ~ 11 %	+26
56 ~ 57.5 %	-4	8 ~ 9.5 %	+27
54.5 ~ 56 %	-3	6.5 ~ 8 %	+28
53 ~ 54.5 %	-2	5 ~ 6.5 %	+29
51.5 ~ 53 %	-1	3.5 ~ 5 %	+30
50 ~ 51.5 %	0	$\leq 3.5\%$	+37

5. VENDOR SPECIFIC REQUEST FOR GPIO ACCESS

GPIO Write

Offset	Field	Size	Value (Hex)	Description
0	bmRequestType	1	43	
1	bRequest	1	01	
2	wValue	2	Value	Bit 0: GPIO value Bit 1: 1: output; 0: input
4	wIndex	2	0000	
6	wLength	2	0000	

GPIO Read

Offset	Field	Size	Value (Hex)	Description
0	bmRequestType	1	C3	
1	bRequest	1	81	
2	wValue	2	Value	Bit 0: GPIO value Bit 1: 1: output; 0: input
4	wIndex	2	0000	
6	wLength	2	0001	

6. USB DESCRIPTORS

The audio and control data are transferred to CM102-A/CM102S via USBDP (Pin 7) and USBDM (Pin8) in full-speed, which correspond to D+ and D- in the USB specification. The descriptors are listed for design reference.

6.1 Device Descriptors

Offset	Field	Size	Value (Hex)	Description
0	bLength	1	12	Total 18 Bytes.
1	bDescriptorType	1	01	Device Descriptor.
2	bcdUSB	2	0110	USB Specification compatible.
4	bDeviceClass	1	00	
5	bDeviceSubClass	1	00	
6	bDeviceProtocol	1	00	
7	bMaxPacketSize0	1	08	Endpoint zero Size = 8 bytes.
8	idVendor	2	0D8C	Vendor ID.
10	idProduct	2	0001	Product ID.
12	bcdDevice	2	0010	
14	iManufacturer	1	01	Index of string descriptor describing manufacturer.
15	iProduct	1	02	Index of string descriptor describing product.
16	iSerialNumber	1	00	Index of string descriptor describing the device's serial number.
17	bNumConfigurations	1	01	Configurations number = 1.

6.2 Configuration Descriptor

The following information is described in the configuration descriptor.

Offset	Field	Size	Value (Hex)	Description
0	bLength	1	09	Total 9 Bytes.
1	bDescriptorType	1	02	Configuration Descriptor.
2	wTotalLength	2	006e	Total length of data returned for this configuration: 110 Bytes.
4	bNumInterfaces	1	02	Number of interfaces supported by this Configuration: 0: control interface. 1: ISO-OUT interface.
5	bConfigurationValue	1	01	
6	iConfiguration	1	00	
7	bmAttributes	1	80	bus Power and non support Remote Wakeup.
8	bMaxPower	2	FA	Maximum power consumption of the USB Device: 500mA.

6.3 USB audio topology diagram

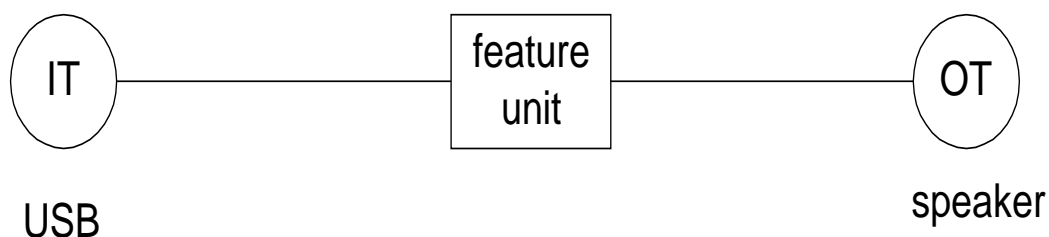

Figure 5 : Topology Diagram

7. ELECTRICAL CHARACTERISTICS

7.1 Absolute maximum rating

Symbol	Parameter	Value	Unit
Dvmin	Min digital supply voltage	- 0.3	V
Dvmax	Max digital supply voltage	+ 6	V
Avmin	Min analog supply voltage	- 0.3	V
Avmax	Max analog supply voltage	+ 6	V
Dvinout	Voltage on any digital input or output pin	-0.3 to +5.5	V
Avinout	Voltage on any analog input or output pin	-0.3 to +5.5	V
Tstg	Storage temperature range	-40 to +125	
ESD (HBM)	ESD human body mode	3500	V
ESD (MM)	ESD machine mode	200	V

7.2 Operation conditions

Parameter	Min	Typ	Max	Unit
Analog supply voltage	4.5	5.0	5.5	V
Digital supply voltage	4.5	5.0	5.5	V
Total power consumption	-	-	50	mA
Operating ambient temperature	0	-	70	

7.3 Electrical Parameters

Parameter	Min	Typ	Max	Unit
VR Input				
Resolution	-	5	-	bit
Input range	0	-	2.25	V
Clock				
Clock input frequency	11.994	12	12.006	MHz
PLL1 output frequency	-	48	-	MHz
PLL2 output frequency	-	12.288	-	MHz
Amplification				
Volume control level	-33	-	+6	dB
Volume control step ⁽¹⁾	-	37	-	Steps

Note: 1) with an additional mute step

7.4 Audio Performance

Parameter	Min	Typ	Max	Unit
DAC				
Resolution	-	16	-	bits
THD + N (-3dBr)	-66	-	-	dB
SNR	82.1	-	-	dB
Silent SNR	90.5	-	-	dB
Dynamic range	82.7	-	-	dB
Frequency response	20	-	20K	Hz
Output voltage (rms)	-	1.1	-	Vrms
Output voltage swing	0.7	-	3.8	V
Power amplifier				
Power supply	4.5	5.0	5.5	V
THD + N (-3dBr)	-53.5	-	-	dB
SNR	82	-	-	dB
Silent SNR	103	-	-	dB
Dynamic range	83.4	-	-	dB
Output voltage (rms)	-	1.34	-	Vrms
Output voltage swing	-	-	4.50 Vpp	V
Maximum output power per channel (RMS value, 4 ohm load)	0.308	-	0.427	W
Maximum output power per channel (RMS value, 6 ohm load)	0.291	-	0.368	W
Maximum output power per channel (RMS value, 8 ohm load)	0.248	-	0.316	W

8. FREQUENCY RESPONSE GRAPHS

8.1 Line Output Series Capacitors : 220µF

C-media Digital Playback (PC-D-A) for Line Output Frequency Response 01/29/01 18:06:34

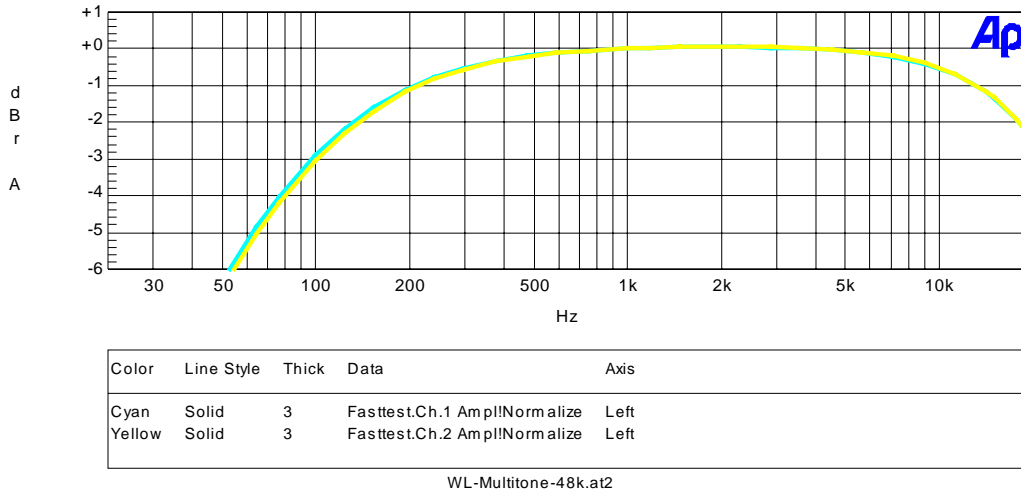

Figure 6 : Frequency Response of CM102-A/S with 220µF Series Capacitor

8.2 Line Output Series Capacitors : 1000µF

C-Media Digital Playback (PC-D-A) for Line Output Frequency Response 01/29/01 18:16:17

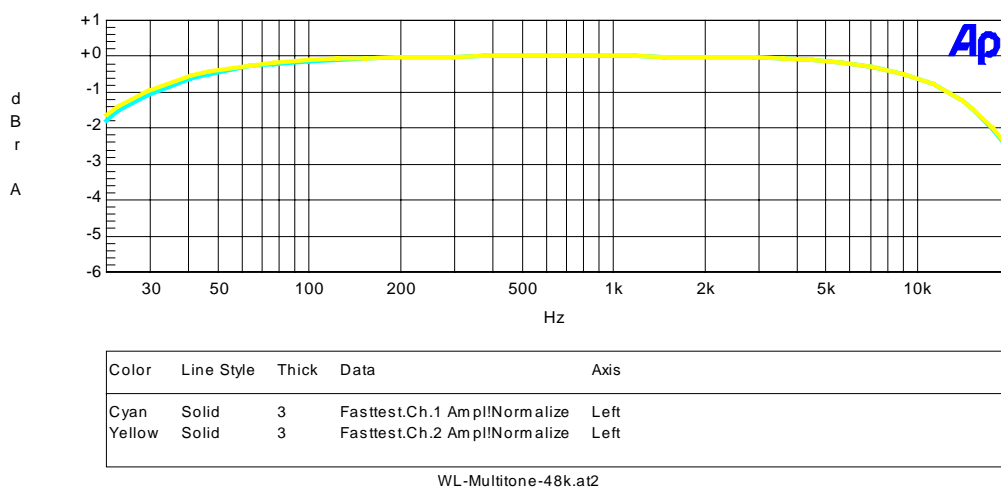

Figure 7 : Frequency Response of CM102-A/S with 1000µF Series Capacitor

9. APPLICATION CIRCUIT REFERENCE

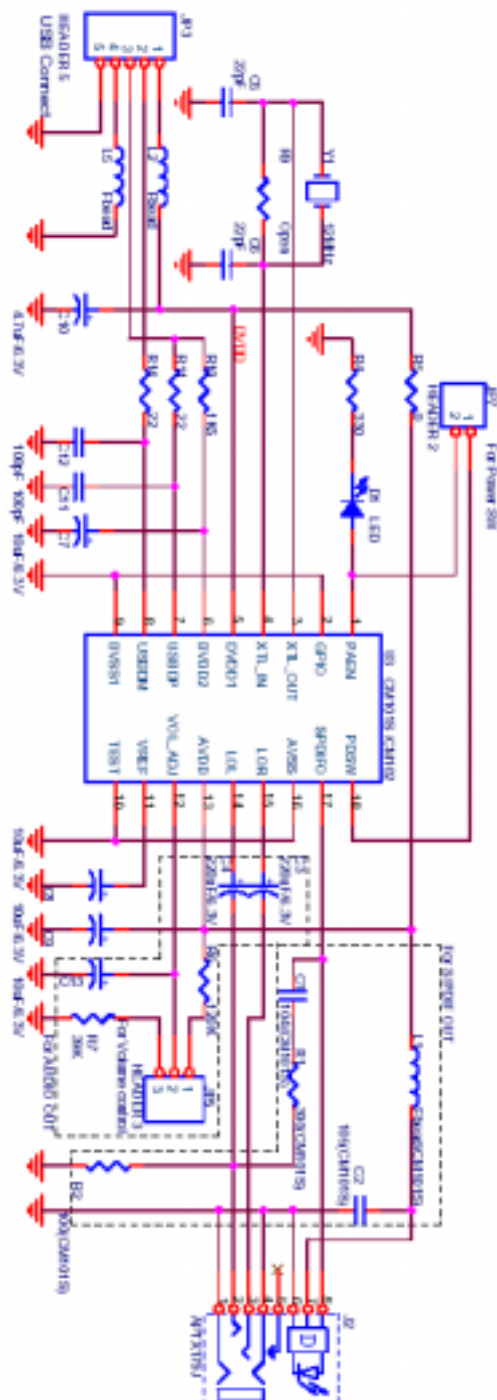

Figure 8 : Application Circuit of CM102-A/S Rev 1.6

10. REFERENCE

USB-IF, USB Specification, Revision 1.1 and 2.0, and USB Audio Device Class Specification, Revision 1.0,.

- End of Specifications -

C-MEDIA ELECTRONICS INC.

6F., 100, Sec. 4, Civil Boulevard, Taipei, Taiwan 106 R.O.C.

TEL:886-2-8773-1100

FAX:886-2-8773-2211

E-mail : sales@cmedia.com.tw URL : <http://www.cmedia.com.tw>