

SOT-23 Plastic-Encapsulate MOSFETS

CJ3415 P-Channel 20-V(D-S) MOSFET

FEATURE

Excellent $R_{DS(ON)}$, low gate charge, low gate voltages

APPLICATIONS

Load switch and in PWM applicatopns

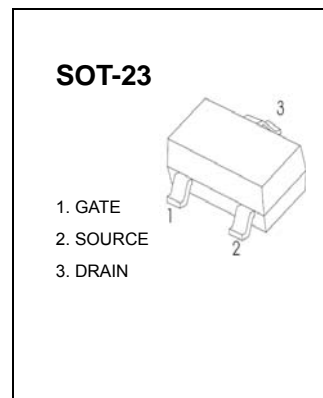

MARKING: R15

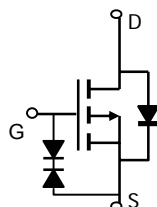

Maximum ratings ($T_a=25^{\circ}\text{C}$ unless otherwise noted)

Parameter	Symbol	Value	Unit
Drain-Source Voltage	V_{DS}	-20	V
Gate-Source Voltage	V_{GS}	± 8	
Continuous Drain Current ($t \leq 10s$)	I_D	-4.0	A
Maximum Power Dissipation ($t \leq 10s$)	P_D	0.35	W
Thermal Resistance from Junction to Ambient	$R_{\theta JA}$	357	$^{\circ}\text{C}/\text{W}$
Operating Junction Temperature	T_J	150	$^{\circ}\text{C}$
Storage Temperature	T_{STG}	-55 ~ +150	$^{\circ}\text{C}$

Electrical characteristics (T_a=25°C unless otherwise noted)

Parameter	Symbol	Test Condition	Min	Typ	Max	Units
Static Parameters						
Drain-source breakdown voltage	V _{(BR) DSS}	V _{GS} = 0V, I _D = -250μA	-20			V
Gate threshold voltage	V _{GS(th)}	V _{DS} = V _{GS} , I _D = -250μA	-0.3		-1	
Gate-body leakage current	I _{GSS}	V _{DS} = 0V, V _{GS} = ±8V			±10	μA
		V _{DS} = 0V, V _{GS} = ±4.5V			±1	
Zero gate voltage drain current	I _{DSS}	V _{DS} = -16V, V _{GS} = 0V			-1	
Drain-source on-state resistance(note1)	R _{DS(on)}	V _{GS} = -4.5V, I _D = -4A			0.050	Ω
		V _{GS} = -2.5V, I _D = -4A			0.060	
		V _{GS} = -1.8V, I _D = -2A			0.073	
Forward transconductance(note2)	g _{FS}	V _{DS} = -5V, I _D = -4A	8			S
Body diode voltage(note2)	V _{SD}	I _S = -1A, V _{GS} = 0V			-1	V
Dynamic Parameters (note3)						
Input capacitance	C _{iss}	V _{DS} = -10V, V _{GS} = 0V, f = 1MHz		1450		pF
Output capacitance	C _{oss}			205		
Reverse transfer capacitance	C _{rss}			160		
Gate resistance	R _g	V _{DS} = 0V, V _{GS} = 0V, f = 1MHz		6.5		Ω
Switching Parameters						
Total gate charge	Q _g	V _{DS} = -10V, V _{GS} = -4.5V, I _D = -4A		17.2		nC
Gate-Source charge	Q _{gs}			1.3		
Gate-drain charge	Q _{gd}			4.5		
Turn-on delay time (note3)	t _{d(on)}	V _{DS} = -10V, V _{GS} = -4.5V R _{GEN} = 3Ω, R _L = 2.5Ω,		9.5		ns
Turn-on rise time(note3)	t _r			17		
Turn-off delay time(note3)	t _{d(off)}			94		
Turn-off fall time(note3)	t _f			35		

Notes:

1. Repetitive rating, pulse width limited by junction temperature.
2. Pulse Test : Pulse width ≤ 300μs, duty cycle ≤ 2%.
3. These parameters have no way to verify.

