

SKY74100-21: Dual-Band Receiver for CDMA and PCS Femtocell Applications

Applications

- Dual-band femtocells

Features

- Supply voltage: 2.7 V to 3.0 V
- Low power operation: 140 mW with supply voltage @ 2.85 V
- Two differential mixer path inputs (800 MHz and 1.9 GHz) and common I/Q differential outputs at the baseband
- Two direct downconverters for CDMA and PCS bands
- Fully integrated UHF VCO for all operating modes. An automatic integrated tuning loop for all process variations is included
- Fully integrated RF PLL (except for the loop filter)
- Fully integrated baseband low pass filters for both I and Q channels
- Internal automatic tuning loop to cover all process variations for integrated filters
- Integrated DCOC, requiring no external stimulus or components
- LGA (40-pin, 6 x 6 x 1 mm) package with downset paddle (MSL3, 260 °C per JEDEC J-STD-020)

NEW

Skyworks offers lead (Pb)-free RoHS (Restriction of Hazardous Substances) compliant packaging.



Description

The SKY74100-21 receiver is a highly integrated device for dual-band Code Division Multiple Access (CDMA) femtocells. The SKY74100-21 supports femtocells in the cellular CDMA and Personal Communications System (PCS) modes.

The device requires a minimum number of external components to complete a CDMA radio subsystem. Included within the package are the downconverters, baseband filters with an auto-tuning loop, UHF Voltage Controlled Oscillator (VCO), RF Phase Locked Loop (PLL), and DC Offset Correction (DCOC). The SKY74100-21 is designed to operate within a supply voltage range of 2.7 V to 3.0 V.

External components needed for operation include matching networks for differential mixer inputs, CDMA/PCS Surface Acoustic Wave (SAW) filters, three bias resistors for accurate bias control over process variation, and two high tolerance load resistors for In-Phase and Quadrature (I/Q) baseband output.

The SKY74100-21 output is a dual-channel, fully differential analog signal at the baseband. Both channels maintain a quadrature phase relationship with each other.

Together with the SKY74092 dual-band, dual-mode LNA, the SKY74100-21 completes the receiver from the RF input to the I/Q baseband outputs.

The 40-pin Land Grid Array (LGA) device package and pinout are shown in Figure 1. Figure 2 shows a functional block diagram for the SKY74100-21.

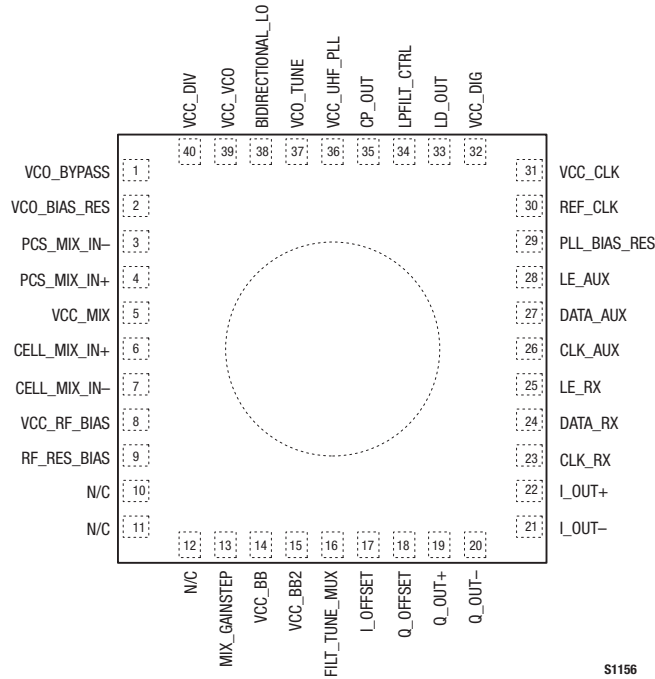

S1156

Figure 1. SKY74100-21 Receiver Pinout – 40-Pin LGA (6 x 6 mm) (Top View)

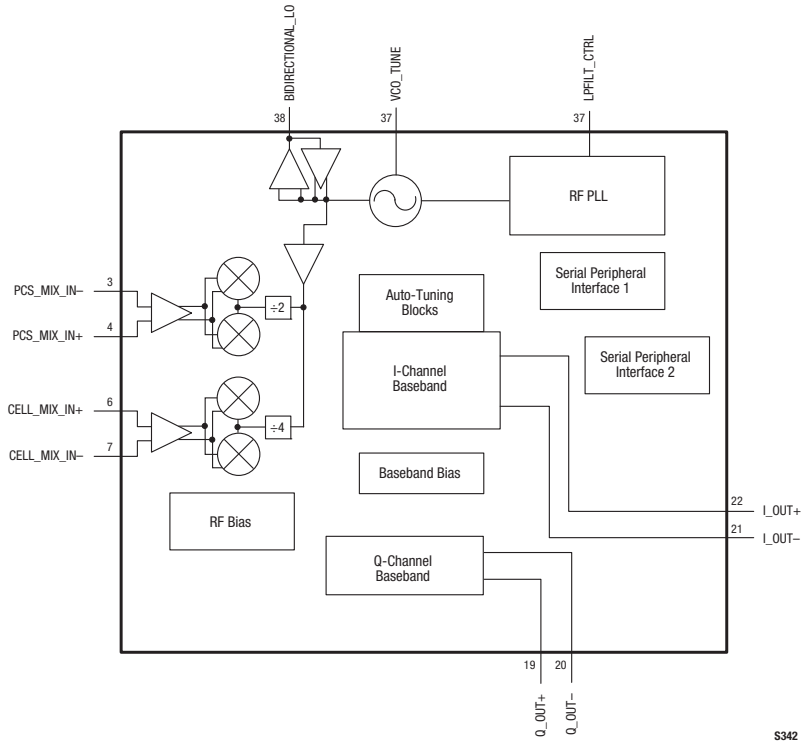

S342

Figure 2. SKY74100-21 Receiver Block Diagram

Technical Description

LNAs

Due to noise and isolation considerations, the CDMA and PCS LNAs are contained on the SKY74092 (refer to the device Data Sheet, document number 103205, for further information).

Mixers

Two mixers with separate differential inputs accommodate CDMA and PCS modes of operation.

Serial Bus Interface

The SKY74100-21 has two read/write, three-wire serial bus interfaces (Auxiliary and Receive). The Auxiliary bus is used for writing to and reading from the UHF VCO and PLL. The Receive bus is used for writing to and reading from the receive path. The Receive bus is shared with the SKY74092 LNA.

Fully Integrated VCO

The VCO is designed to operate at twice the frequency of the PCS receive band and four times the frequency of the CDMA receive band. The carrier frequency and quadrature are then achieved by dividing the VCO signal by either two or four.

The analog tuning range is sufficient to cover frequency variations due to supply and temperature changes under normal operating conditions. This ensures that the PLL is always locked.

Continuous Time Low Pass Filters

The receive filter has two primary tasks: to set the receive bandwidth, and to reject adjacent and alternate channel blockers. These functions are formalized by the requirements placed on the 900 kHz and 1.25 MHz blockers for the cellular and PCS bands, respectively, with further attenuation requirements at 1.7 MHz and 2.05 MHz.

There are two identical receive filters, one for the I channel and one for the Q channel. A 15 dB gain step is provided in the filter, programmed either through the three-wire bus or through the MIX_GAINSTEP signal (pin 13).

DC Offset Correction (DCOC)

DCOC is provided as part of the baseband filter transfer function. A high pass cut-off is provided in the signal path. No external components are required. However, the high pass cut-off

frequency can be adjusted from 640 Hz to 1.91 kHz using the Auxiliary serial bus.

RF PLL

The RF PLL is fully integrated with the exception of the loop filter components. The pre-scalar has been designed to directly use the VCO frequency to maintain resolution without impacting settling time.

A power on reset signal is generated on start-up. This is used to reset all flip-flops in the PLL and as a reference to enable on-chip tuning sequences.

Package and Handling Information

Since the device package is sensitive to moisture absorption, it is baked and vacuum packed before shipping. Instructions on the shipping container label regarding exposure to moisture after the container seal is broken must be followed. Otherwise, problems related to moisture absorption may occur when the part is subjected to high temperature during solder assembly.

The SKY74100-21 is rated to Moisture Sensitivity Level 3 (MSL3) at 260 °C. It can be used for lead or lead-free soldering. For additional information, refer to the Skyworks Application Note, *PCB Design & SMT Assembly/Rework Guidelines for RFLGA Packages*, document number 103147.

Care must be taken when attaching this product, whether it is done manually or in a production solder reflow environment. Production quantities of this product are shipped in a standard tape and reel format.

Electrical and Mechanical Specifications

Signal pin assignments and functional pin descriptions are described in Table 1. The absolute maximum ratings of the SKY74100-21 are provided in Table 2. The recommended operating conditions are specified in Table 3 and electrical specifications are provided in Tables 4 through 7.

An application schematic diagram for the SKY74100-21 is shown in Figure 3. A PCB footprint drawing is provided in Figure 4, package dimensions for the 40-pin LGA are shown in Figure 5, and the tape and reel dimensions are provided in Figure 6.

Table 1. SKY74100-21 Signal Descriptions

Pin #	Name	Description	Pin #	Name	Description
1	VCO_BYPASS	External bypass capacitor for VCO bias.	21	I_OUT-	Negative I channel baseband output. Requires a shunt load resistor of 5 kΩ shared with pin 22.
2	VCO_BIAS_RES	External resistor to set VCO bias.	22	I_OUT+	Positive I channel baseband output. Shunt load shared with pin 21.
3	PCS_MIX_IN-	Negative RF input for PCS mixer. Requires external match.	23	CLK_RX	Clock for receive serial I/O.
4	PCS_MIX_IN+	Positive RF input for PCS mixer. Requires external match.	24	DATA_RX	Data for receive serial I/O.
5	VCC_MIX	Supply for RF mixer bias.	25	LE_RX	Latch enable for receive serial I/O.
6	CELL_MIX_IN+	Positive RF input for CDMA mixer. Requires external match.	26	CLK_AUX	Clock for auxiliary serial I/O.
7	CELL_MIX_IN-	Negative RF input for CDMA mixer. Requires external match.	27	DATA_AUX	Data for auxiliary serial I/O.
8	VCC_RF_BIAS	Supply for RF bias block.	28	LE_AUX	Latch enable for auxiliary serial I/O.
9	RF_RES_BIAS	External resistor to set RF bias for LNA and mixers.	29	PLL_BIAS_RES	External resistor for PLL bias..
10	N/C	No connection	30	REF_CLK	Reference clock input (TCXO).
11	N/C	No connection	31	VCC_CLK	Supply for TCXO reference buffer.
12	N/C	No connection	32	VCC_DIG	Digital supply.
13	MIX_GAINSTEP	Control pin used to switch the mixer and baseband gain.	33	LD_OUT	Lock detect output for PLL. This is an open drain output. Requires a 10 kΩ pullup for VCC.
14	VCC_BB	Supply for baseband block.	34	LPFILT_CTRL	Provides a bit from internal serial I/O to switch between external loop filter components. This is an open drain output.
15	VCC_BB2	Supply for baseband.	35	CP_OUT	Charge pump output. Connected to external loop filter.
16	FILT_TUNE_MIX	Ground	36	VCC_UHF_PLL	Supply for RF PLL.
17	I_OFFSET	No connection	37	VCO_TUNE	VCO tuning voltage. Tuning range is 0.5 V to 2.5 V.
18	Q_OFFSET	No connection	38	BIDIRECTIONAL_LO	No connection
19	Q_OUT+	Positive Q channel baseband output. Requires a 5 kΩ shunt load resistor shared with pin 20.	39	VCC_VCO	Supply for VCO core.
20	Q_OUT-	Negative Q channel baseband output. Shunt load shared with pin 19.	40	VCC_DIV	Supply for LO dividers.

Table 2. SKY74100-21 Absolute Maximum Ratings

Parameter	Symbol	Minimum	Typical	Maximum	Units
Supply voltage	VCC	-0.3		+3.6	V
Input voltage range	V _{IN}	-0.3		VCC	V
LNA input power				+5	dBm
Power dissipation				600	mW
Storage temperature	T _{STG}	-40		+125	°C
Ambient operating temperature	T _A	-30		+85	°C

Note: Exposure to maximum rating conditions for extended periods may reduce device reliability. There is no damage to device with only one parameter set at the limit and all other parameters set at or below their nominal value.

CAUTION: Although this device is designed to be as robust as possible, Electrostatic Discharge (ESD) can damage this device. This device must be protected at all times from ESD. Static charges may easily produce potentials of several kilovolts on the human body or equipment, which can discharge without detection. Industry-standard ESD precautions should be used at all times.

Table 3. SKY74100-21 Recommended Operating Conditions

Parameter	Symbol	Minimum	Typical	Maximum	Units
Supply voltage	VCC	2.7	2.85	3.0	V
Operating temperature range	T _A	-30	+25	+85	°C
Z _{IN} of logic control inputs			50		kΩ
Logic level high		VCC - 0.5		VCC	V
Logic level low		0		0.5	V

Table 4. SKY74100-21 Electrical Specifications (Note 1) (1 of 2)
(T_A = +25 °C, VCC = 2.85 V Unless Otherwise Noted)

Parameter	Symbol	Test Condition	Min	Typical	Max	Units
CDMA 800 MHz Downconverter and Filter – High Gain Mode						
Output frequency range			0		0.65	MHz
Voltage gain			49			dB
Noise figure	NF	Mixer and filters			13.5	dB
Third Order Input Intercept Point	IIP3			3		dBm
Second Order Input Intercept Point	IIP2		40			dBm
P1dB @ input		High gain	-15			dBm
RF input impedance (differential)				100		Ω
RF input return loss (differential)					-10	dB
LO leakage at mixer input					-68	dBm
Total supply current (adjustable)					70	mA
CDMA 800 MHz Downconverter and Filter – Low Gain Mode						
Gain step			15		17	dB
P1dB @ input		Low gain	-15			dBm
LO leakage @ mixer input					-68	dBm

Table 4. SKY74100-21 Electrical Specifications (Note 1) (2 of 2)
(T_A = +25 °C, V_{CC} = 2.85 V Unless Otherwise Noted)

Parameter	Symbol	Test Condition	Min	Typical	Max	Units
PCS 1900 MHz Downconverter and Filter – High Gain Mode						
Output frequency range			0		0.65	MHz
Voltage gain			49			dB
Noise figure	NF	Mixer and filters		10.0	13.5	dB
Third Order Input Intercept Point	IIP3		2			dBm
Mixer Second Order Input Intercept Point	IIP2		40			dBm
P1dB @ input		High gain	-15			dBm
RF input impedance (differential)				100		Ω
RF input return loss (differential)					-10	dB
LO leakage at mixer input					-72	dBm
Total supply current (adjustable)					64	mA
PCS 1900 MHz Downconverter and Filter – Low Gain Mode						
Gain step			15		17	dB
P1dB @ input		Low gain	-15			dBm
LO leakage @ mixer input					-72	dBm

Note 1: Performance is guaranteed only under the conditions listed in this Table.

Table 5. SKY74100-21 UHF VCO Specifications (Note 1)
(T_A = +25 °C, V_{CC} = 2.85 V Unless Otherwise Noted)

Parameter	Symbol	Test Condition	Min	Typical	Max	Units
VCO frequency:						
CDMA			3298		3576	MHz
PCS			3702		3980	MHz
Phase noise, CDMA		@ VCO frequency integrated at 900 ± 630 kHz offset			-63	dBc
		@ carrier frequency integrated at 900 ± 630 kHz offset			-75	dBc
Phase noise, PCS		@ VCO frequency integrated at 1250 ± 630 kHz offset			-67	dBc
		@ carrier frequency integrated at 1250 ± 630 kHz offset			-73	dBc
Current consumption (PCS/CDMA)					19	mA

Note 1: Performance is guaranteed only under the conditions listed in this Table.

Table 6. SKY74100-21 PLL Specifications (Note 1)
(TA = +25 °C, VCC = 2.85 V Unless Otherwise Noted)

Parameter	Symbol	Test Condition	Min	Typical	Max	Units
Reference range				19.2		MHz
Phase detector frequency minimum range			10		1000	kHz
Reference input sensitivity			300			mVp-p
Charge pump current: RF (sel 1) RF (sel 2) RF (sel 3) RF (sel 4)				0.8 1.5 2.7 3.6		mA mA mA mA
Charge pump output voltage compliance, minimum range			0.5		VDD – 0.5	V
PLL phase noise: integrated from 1 kHz to 630 kHz at carrier		CDMA, F _{COMP} = 120 kHz PCS, F _{COMP} = 100 kHz		2.5		degrees rms (Note 2)
Supply current					6	mA

Note 1: Performance is guaranteed only under the conditions listed in this Table.

Note 2: Equivalent to –27 dBc.

Table 7. SKY74100-21 Output Interface Specifications (Note 1)
(TA = +25 °C, VCC = 2.85 V Unless Otherwise Noted)

Parameter	Symbol	Test Condition	Min	Typical	Max	Units
Nominal CDMA and PCS output signal level		Input level = –100 dBm Input level = –113 dBm		–57 –56		dBV dBV
Output common mode voltage				VCC/2		V
DC offset at CDMA and PCS output					15	mV
Blocker rejection @ CDMA and PCS output		Blocker frequency from carrier ≥ 900 kHz	40			dB
Inband ripple CDMA and PCS (peak-to-peak)		10 kHz < frequency offset < 615 kHz			1.5	dB
I/Q amplitude imbalance					0.5	dB
I/Q phase imbalance					3	degrees

Note 1: Performance is guaranteed only under the conditions listed in this Table.

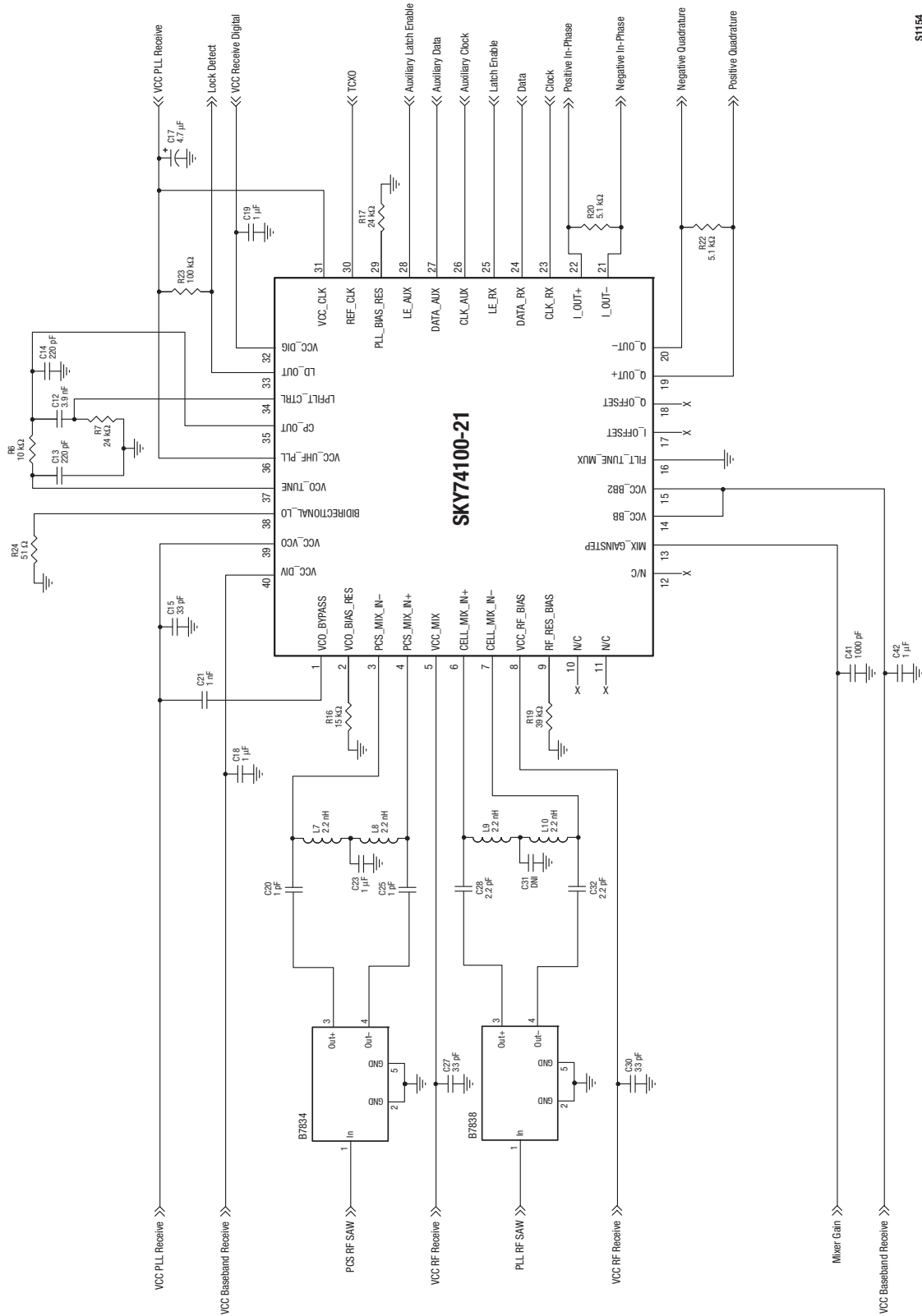

Figure 3. SKY74100-21 Application Schematic

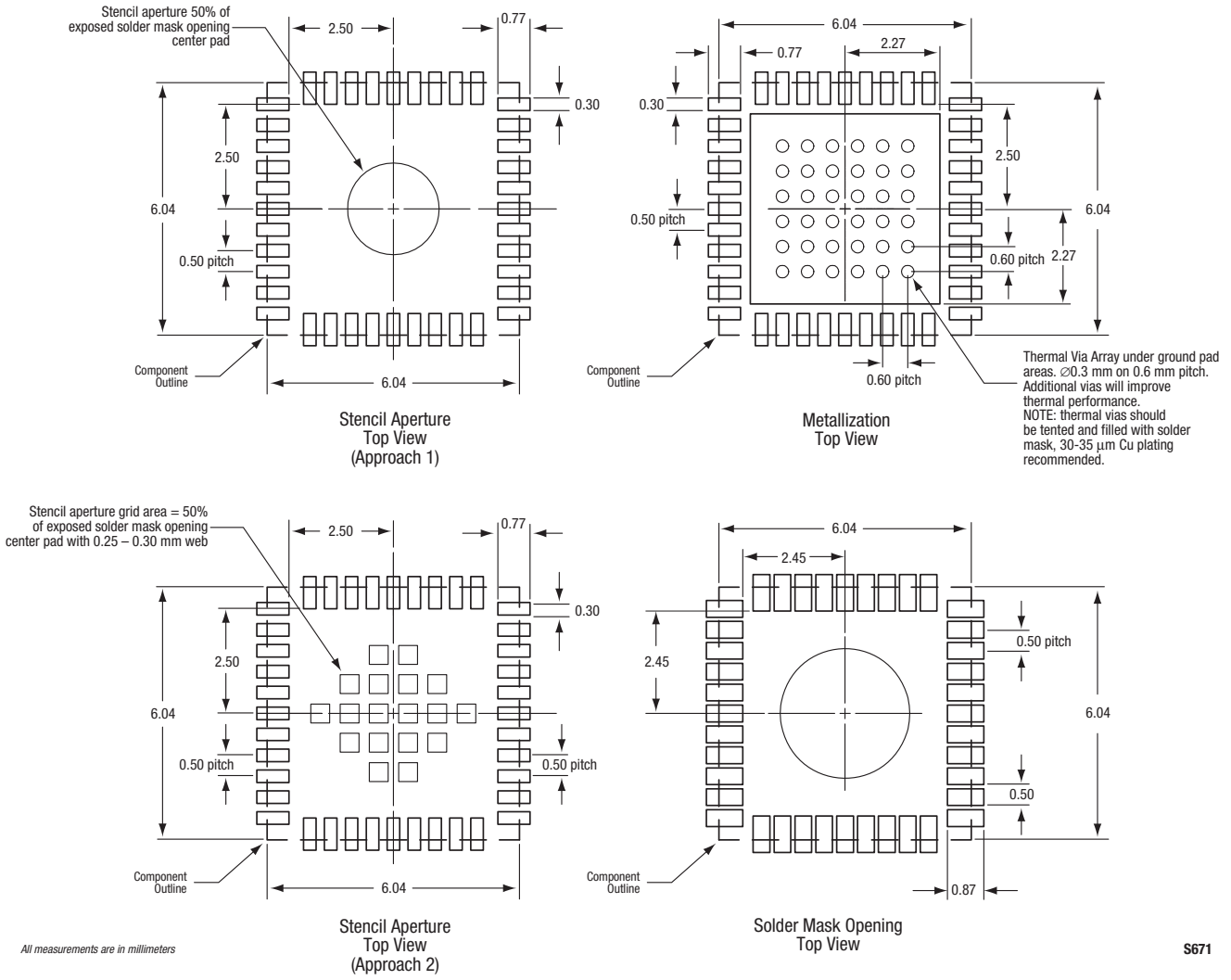
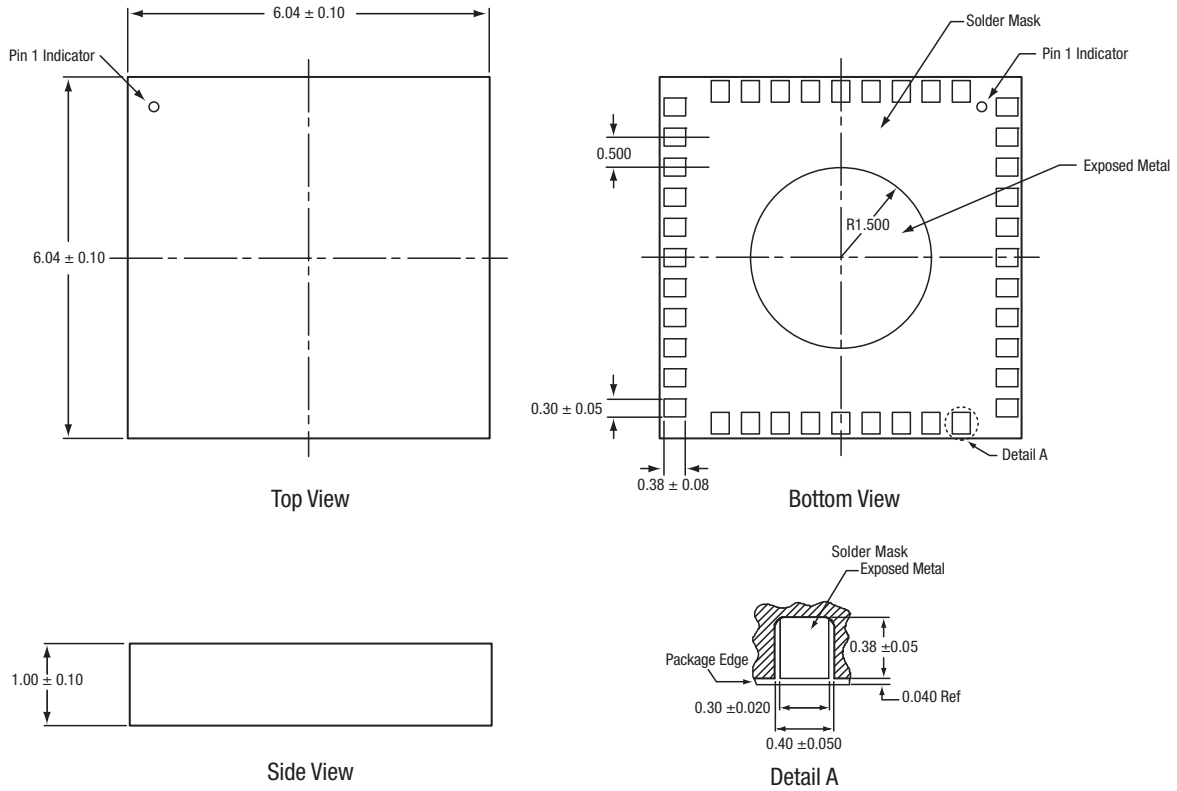

Figure 4. Phone Board Layout Footprint For The SKY74100-21 6 x 6 LGA

DATA SHEET • SKY74100-21 CDMA RECEIVER



All dimensions are in millimeters

S311

Figure 5. SKY74100-21 40-Pin LGA Package Dimension Drawing

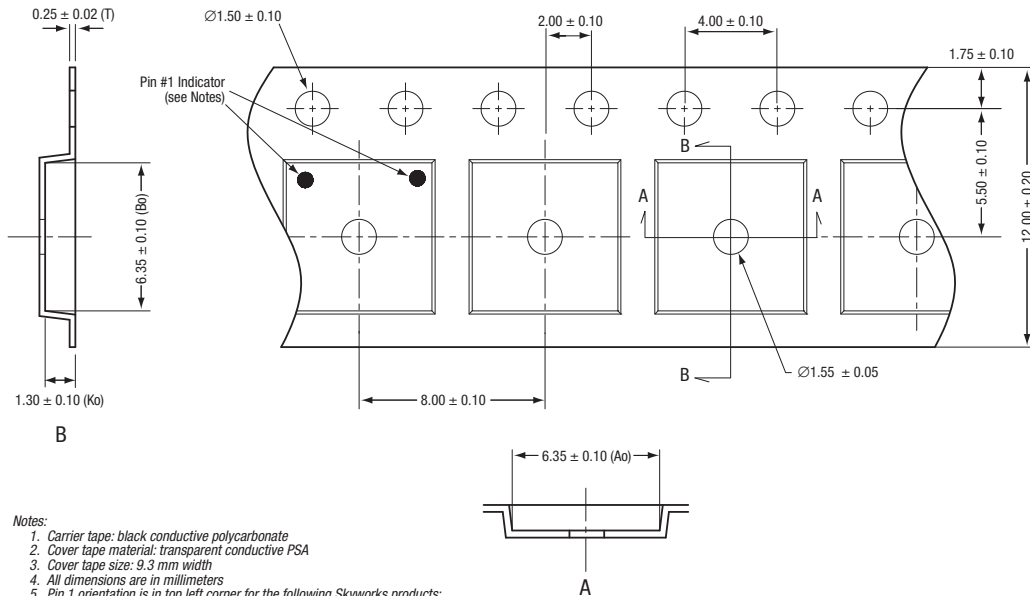

Notes:

1. Carrier tape: black conductive polycarbonate
2. Cover tape material: transparent conductive PSA
3. Cover tape size: 9.3 mm width
4. All dimensions are in millimeters
5. Pin 1 orientation is in top left corner for the following Skyworks products:

SKY73022-21, -31
SKY73023-21, -31

For all other 6 x 6 mm MCM/RFLGA products, pin 1 orientation is in top right corner.

S1850

Figure 6. SKY74100-21 Tape and Reel Dimensions

Ordering Information

Model Name	Manufacturing Part Number	Evaluation Board Part Number
SKY74100-21 CDMA Receiver	SKY74100-21	*** TBD ***

Copyright © 2007, 2008, 2010 Skyworks Solutions, Inc. All Rights Reserved.

Information in this document is provided in connection with Skyworks Solutions, Inc. ("Skyworks") products or services. These materials, including the information contained herein, are provided by Skyworks as a service to its customers and may be used for informational purposes only by the customer. Skyworks assumes no responsibility for errors or omissions in these materials or the information contained herein. Skyworks may change its documentation, products, services, specifications or product descriptions at any time, without notice. Skyworks makes no commitment to update the materials or information and shall have no responsibility whatsoever for conflicts, incompatibilities, or other difficulties arising from any future changes.

No license, whether express, implied, by estoppel or otherwise, is granted to any intellectual property rights by this document. Skyworks assumes no liability for any materials, products or information provided hereunder, including the sale, distribution, reproduction or use of Skyworks products, information or materials, except as may be provided in Skyworks Terms and Conditions of Sale.

THE MATERIALS, PRODUCTS AND INFORMATION ARE PROVIDED "AS IS" WITHOUT WARRANTY OF ANY KIND, WHETHER EXPRESS, IMPLIED, STATUTORY, OR OTHERWISE, INCLUDING FITNESS FOR A PARTICULAR PURPOSE OR USE, MERCHANTABILITY, PERFORMANCE, QUALITY OR NON-INFRINGEMENT OF ANY INTELLECTUAL PROPERTY RIGHT; ALL SUCH WARRANTIES ARE HEREBY EXPRESSLY DISCLAIMED. SKYWORKS DOES NOT WARRANT THE ACCURACY OR COMPLETENESS OF THE INFORMATION, TEXT, GRAPHICS OR OTHER ITEMS CONTAINED WITHIN THESE MATERIALS. SKYWORKS SHALL NOT BE LIABLE FOR ANY DAMAGES, INCLUDING BUT NOT LIMITED TO ANY SPECIAL, INDIRECT, INCIDENTAL, STATUTORY, OR CONSEQUENTIAL DAMAGES, INCLUDING WITHOUT LIMITATION, LOST REVENUES OR LOST PROFITS THAT MAY RESULT FROM THE USE OF THE MATERIALS OR INFORMATION, WHETHER OR NOT THE RECIPIENT OF MATERIALS HAS BEEN ADVISED OF THE POSSIBILITY OF SUCH DAMAGE.

Skyworks products are not intended for use in medical, lifesaving or life-sustaining applications, or other equipment in which the failure of the Skyworks products could lead to personal injury, death, physical or environmental damage. Skyworks customers using or selling Skyworks products for use in such applications do so at their own risk and agree to fully indemnify Skyworks for any damages resulting from such improper use or sale.

Customers are responsible for their products and applications using Skyworks products, which may deviate from published specifications as a result of design defects, errors, or operation of products outside of published parameters or design specifications. Customers should include design and operating safeguards to minimize these and other risks. Skyworks assumes no liability for applications assistance, customer product design, or damage to any equipment resulting from the use of Skyworks products outside of stated published specifications or parameters.

Skyworks, the Skyworks symbol, and "Breakthrough Simplicity" are trademarks or registered trademarks of Skyworks Solutions, Inc., in the United States and other countries. Third-party brands and names are for identification purposes only, and are the property of their respective owners. Additional information, including relevant terms and conditions, posted at www.skyworksinc.com, are incorporated by reference.